



**RAD HARD DUAL
POSITIVE LDO
ADJ VOLTAGE REGULATOR**

5953RH

FEATURES:

- Manufactured using  Space Qualified RH3080 Die
- Total Dose Hardened to 300 Krads(Si) (Method 1019.7 Condition A)
- Low Dropout Voltage
- Wide Input Voltage Range
- Dual Output Adjustable to Zero Volts
- Output Current to 1.0A Each Output
- Outputs May Easily be Paralleled for Increased Output Current
- Internal Thermal Overload and Current Limit Protection
- Contact TTM Technologies for MIL-PRF-38534 Qualification Status

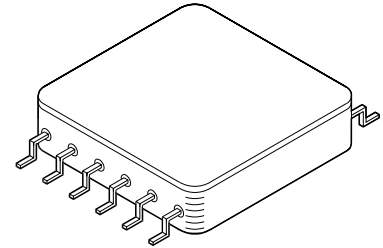

DESCRIPTION:

The MSK5953RH is a radiation hardened, low dropout, dual linear regulator. Each regulator is capable of up to 1.0A output current and can easily be paralleled for increased current capability and increased heat spreading. The output voltage is selected through the use of a single resistor and may be adjusted as low as 0V. The MSK5953RH regulators also have internal current limit and thermal protection. These features combined with low θ_{jc} , make the MSK5953RH regulator an excellent choice for many space applications. The MSK5953RH is packaged in a hermetically sealed 12 pin flatpack that is lead formed for surface mount applications.

EQUIVALENT SCHEMATIC

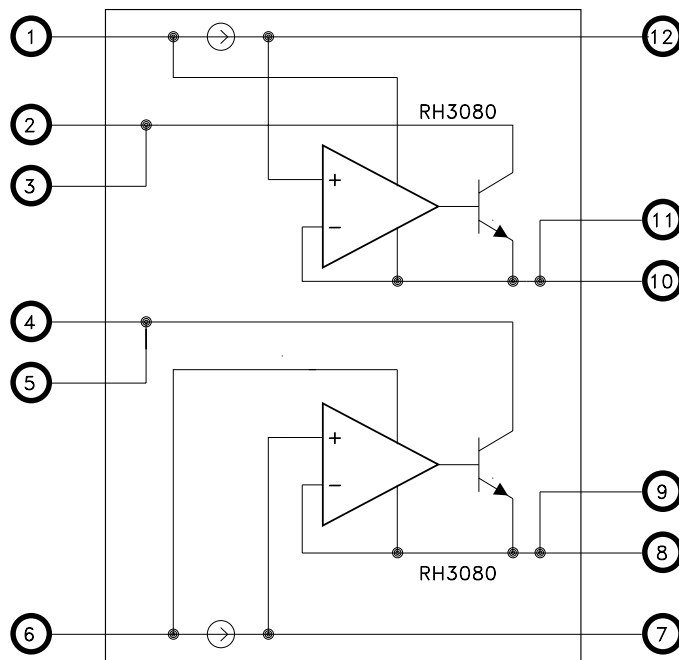

TYPICAL APPLICATIONS

- Post Regulator for Switching Supplies
- Low Output Voltage Power Supplies
- High Efficiency Linear Regulator
- Satellite System Power Supply
- FPGA and Microprocessor Power Supply
- Coincident Output Tracking

PIN-OUT INFORMATION

1	CTLA	7	SET B
2	VIN A	8	VOUT B
3	VIN A	9	VOUT B
4	VIN B	10	VOUT A
5	VIN B	11	VOUT A
6	CTL B	12	SET A

CASE = ISOLATED

 and the Linear Technology logo are registered trademarks and RH3080 is a copyright of Linear Technology Corporation

ABSOLUTE MAXIMUM RATINGS ^⑩

V _{IN} Input Voltage ... ^⑦	+40V, -0.3V	T _{ST} Storage Temperature Range ... ^⑫	-65°C to +150°C
V _{CTL} Control Voltage ... ^⑦	+40, -0.3V	T _{LD} Lead Temperature Range	(10 Seconds) 300°C
P _D Power Dissipation	Internally Limited	T _C Case Operating Temperature	MSK5953RH -40°C to +85°C
I _{OUT} Output Current (Each Output ^⑧	1.0A	MSK5953K/H -55°C to +125°C	ESD Rating Class 2
T _J Junction Temperature	150°C		

ELECTRICAL SPECIFICATIONS

Parameter	Test Conditions ^⑨ ^⑪	Group A Subgroup	MSK5953K/H			MSK5953RH			Units	
			Min.	Typ.	Max.	Min.	Typ.	Max.		
Set Pin Current (I _{SET})	V _{CTL} = V _{IN} = 3.0V V _{OUT} = 1.0V 1mA ≤ I _{LOAD} ≤ 0.8A	1	9.80	10.0	10.20	9.80	10.0	10.20	uA	
		2, 3	9.80	-	10.30	-	-	-	uA	
		Post Radiation	1	9.7	-	10.5	9.7	-	10.5	uA
Output Offset Voltage (V _{OS})	V _{CTL} = V _{IN} = 3.0V V _{OUT} = 1.0V I _{LOAD} = 1mA	1	-5	0	5	-5	0	5	mV	
		2, 3	-6	-	6	-	-	-	mV	
Load Regulation (ΔV _{OS})	V _{CTL} = V _{IN} = 3.0V V _{OUT} = 1.0V 1mA ≤ I _{LOAD} ≤ 0.8A	1	-14	-	14	14	-	14	mV/A	
		2, 3	-18	-	18	-	-	-	mV/A	
		(ΔI _{SET}) ^②	1	-	-0.1	-	-	-0.1	-	nA
Line Regulation (ΔI _{SET})	3V ≤ V _{IN} = V _{CTL} ≤ 25V V _{OUT} = 1.0V I _{LOAD} = 1mA	1	-0.5	-	0.5	-0.5	-	0.5	nA/V	
		2, 3	-1.0	-	0.5	-1.0	-	-	nA/V	
		Post Radiation	1	-0.7	-	0.7	-0.7	-	0.7	nA/V
		(ΔV _{OS}) ^②	1	-	0.003	-	-	0.003	-	mV/V
V _{IN} Dropout Voltage	V _{OUT} = 1.0V I _{LOAD} = 0.8A V _{CTL} = 3.0V	1	-	300	500	-	-	500	mV	
		2, 3	-	-	600	-	-	-	mV	
C _{TL} Pin Dropout Voltage	V _{OUT} = 1.0V I _{LOAD} = 0.8A V _{IN} = 3.0V	1	-	-	1.6	-	-	1.6	V	
		2, 3	-	-	1.7	-	-	-	V	
C _{TL} Pin Current	V _{IN} = 2.0V V _{OUT} = 1.0V V _{CTL} = 3.0V I _{LOAD} = 100mA	1	-	4.5	6.6	-	4.5	6.6	mA	
		2, 3	-	-	6.6	-	-	-	Ma	
Current Limit ^⑧	V _{CTL} = V _{IN} = 5.0V V _{OUT} = 1.0V	1	0.9	1.1	-	0.9	1.1	-	A	
		2, 3	0.9	-	-	-	-	-	A	
Minimum Load Current ^⑥	V _{CTL} = V _{IN} = 25V	-	-	-	1	-	-	1	mA	
Ripple Rejection ^②	F = 120Hz ΔV _{IN} = 0.5V _{pp}	-	-	75	-	-	75	-	dB	
Thermal Resistance ^②	Junction to Case @ 125°C	-	-	9.9	10.5	-	9.9	10.5	°C/W	

NOTES:

- ① Output is decoupled to ground using a 220μF tantalum low ESR capacitor in parallel with a 0.1μF ceramic capacitor unless otherwise specified. (See Figure 1).
- ② Guaranteed by design but not tested. Typical parameters are representative of actual device performance but are for reference only.
- ③ Industrial grade devices shall be tested to subgroup 1 unless otherwise specified.
- ④ Military grade ("H" suffix) and space grade ("K" suffix) devices shall be 100% tested to subgroups 1, 2 and 3.
- ⑤ Subgroup 1 T_A = T_C = +25°C
Subgroup 2 T_A = T_C = +125°C
Subgroup 3 T_A = T_C = -55°C
- ⑥ Minimum load current verified while testing line regulation.
- ⑦ Voltage is measured with respect to V_{OUT}.
- ⑧ The output current limit is dependant on the input to output voltage differential (V_{IN}-V_{OUT}). At V_{IN}-V_{OUT}>26V the available output current may be reduced to zero amps. Refer to the current limit curve for typical current limit characteristics.
- ⑨ All limits and specifications apply to each individual regulator.
- ⑩ Continuous operation at or above absolute maximum ratings may adversely effect the device performance and/or life cycle.
- ⑪ Pre and Post irradiation limits at 25°C, up to 300 Krads(Si) TID, are identical unless otherwise specified.
- ⑫ Internal solder reflow temperature is 180°C, do not exceed.

APPLICATION NOTES

OUTPUT VOLTAGE

A single resistor (R_{SET}) from the SET pins to ground creates the reference voltage for the internal Error Amplifier. The MSK5953RH SET pins each supply a constant current of $10\mu A$ that develops the reference voltage. The output voltage is simply $R_{set} \times 10\mu A$. In the event that both outputs will be the same value, both SET pins may be tied together and a single resistor used for output voltage selection, according to the formula $V_{OUT} = R_{SET} \times 20\mu A$. Since the output is internally driven by a unity-gain amplifier, an alternative to using R_{set} is to connect a high quality reference source to the SET pin. With a minimum load requirement of $1mA$ on the Output, the Output Voltage can be adjusted to near $0V$. To bring the output voltage to $0V$, the load must be connected to a slightly negative voltage supply to sink the $1mA$ minimum load current from a $0V$ output.

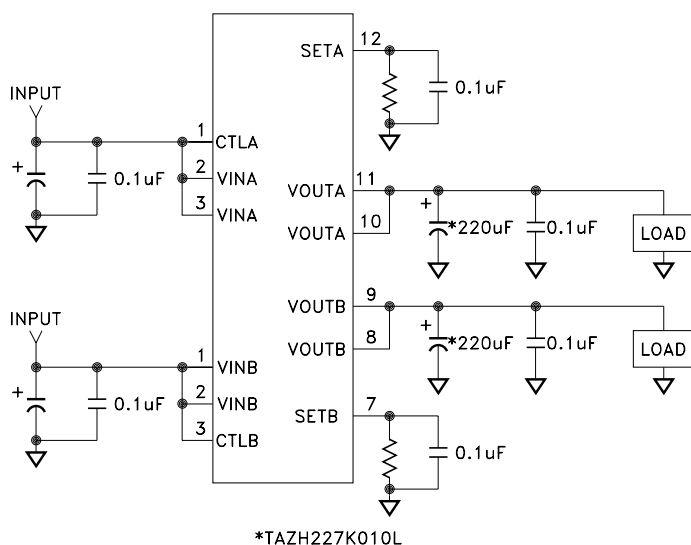

FIGURE 1

OUTPUT CAPACITANCE

For stability purposes, the MSK5953RH requires a minimum output capacitor of $10\mu F$ with an ESR of 0.5Ω or less. Tantalum or ceramic capacitors are recommended. A larger capacitance value and lower ESR will improve transient response for increased load current changes. Consideration must also be given to temperature characteristics of the capacitors used.

ADDITIONAL STABILITY

Capacitors placed in parallel with the SET pin resistors to ground, will improve the output transient response and filter noise in the system. To reduce output noise, typically less than $100pF$ is all that will be required. Capacitors up to $1\mu F$ can be used, however consideration must be given to the effect the time constant created will have on the startup time.

LOAD REGULATION

The MSK5953RH specified load regulation is Kelvin Sensed, therefore the parasitic resistance of the system must be considered to design an acceptable load regulation. The overall load regulation includes the specified MSK5953RH load regulation plus the parasitic resistance multiplied by the load current as shown in Figure 2. R_{SO} is the series resistance of all conductors between the MSK5953RH output and the load. It will directly increase output load regulation error by a voltage drop of $\Delta I_o \times R_{SO}$. R_{SS} is the series resistance between the set pin and the load. R_{SS} will have little effect on load regulation if the set pin trace is connected as close to the load as possible keeping the load return current on a separate trace as shown. R_{SR} is the series resistance of all of the conductors between the load and the input power source return. R_{SR} will not effect load regulation if the set pin is connected with a Kelvin Sense type connection as shown in Figure 2, but it will increase the effective dropout voltage by a factor of $I_o \times R_{SR}$. Keeping R_{SO} and R_{SR} as low as possible will ensure minimal voltage drops and wasted power.

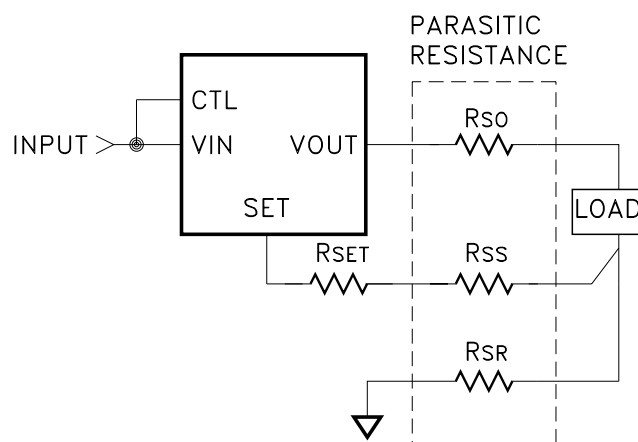

(Each Regulator)
FIGURE 2

APPLICATION NOTES CONT'D

INCREASED CURRENT CAPACITY

When currents greater than 1.0A are needed, the MSK5953RH's outputs may be paralleled to double the current capacity. As shown in Figure 3, the VIN and SET pins must be tied together. The VOUT pins are connected to the load with consideration to the conductor resistance. The conductor resistance of each MSK5953RH VOUT connection to the load, must be equal to create equal load sharing. As little as 10mΩ ballast resistance typically ensures better than 80% equal sharing of load current at full load. Additional consideration must be given to the effect the additional VOUT conductor resistance has on load regulation; see paragraph titled "Load Regulation".

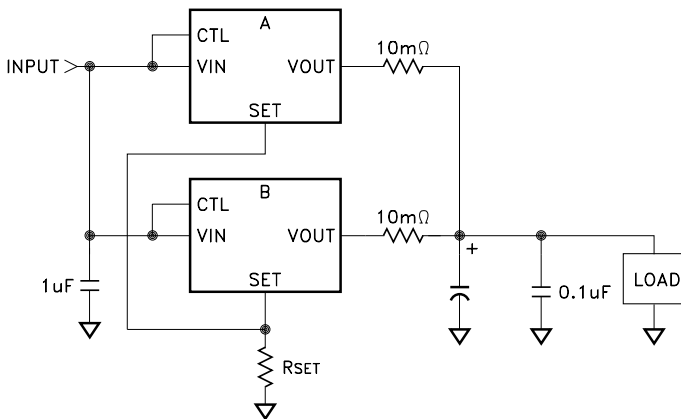

FIGURE 3

IMPROVING INITIAL ACCURACY AND REDUCING TEMPERATURE DRIFT

The initial output accuracy of the MSK5953RH due to set pin current tolerance and set point resistor accuracy can be reduced to 0.2% using the MSK109RH radiation hardened precision reference. Minimal drift of the MSK109RH from temperature extremes and irradiation ensure very tight regulation. The circuit can be configured to use the 2.5V reference to directly set the output at 2.5V or with a slight variation it can provide any output within the operating range of the MSK5953RH down to 0V output. Select RS to maintain between 1mA and 10mA of current through the reference; see Figure 4 below. RS may be tied to VIN or another power source. The optional trim resistor can be used to further trim out initial output and system error. Reference the MSK109RH data sheet for application circuits that provide stable output voltages across the full operating range of the MSK5953RH including down to 0V output and the operating characteristics of the MSK109RH.

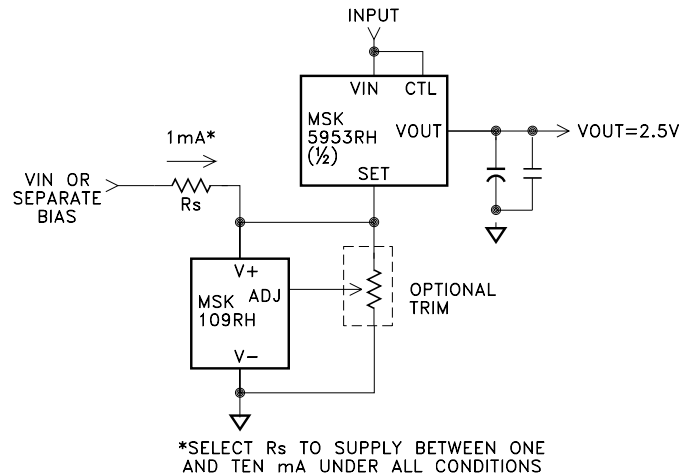

FIGURE 4

ADDING SHUTDOWN

The MSK5953RH can be easily shutdown by either reducing RSET to 0Ω or connecting a transistor from the set pin to ground. By connecting two transistors, as shown in Figure 5, a low current voltage source is all that is required to take the set pin to ground as well as pull the output voltage to ground. Q2 pulls the output voltage to ground when no load is present and only needs to sink 10mA. Use a low leakage switching diode between VOUT and SET to avoid overstress during shutdown transitions.

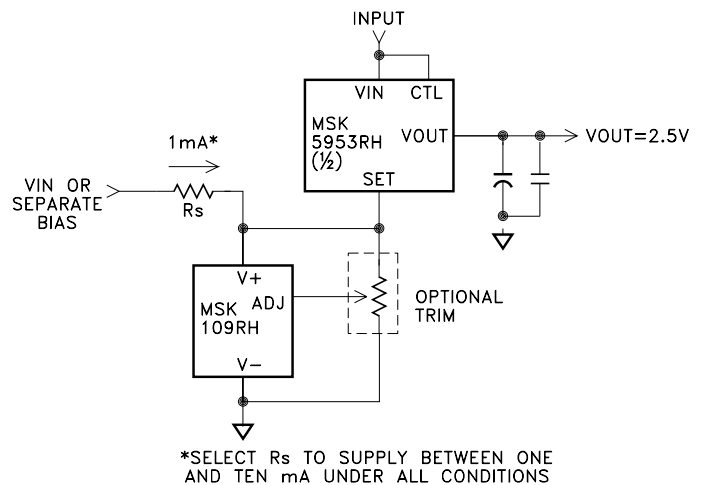

FIGURE 5

APPLICATION NOTES CONT'D

COINCIDENT TRACKING

For applications that require multiple output voltages and tight control over voltage differentials, the coincident tracking shown in Figure 6 may be used. In this configuration regulator B is configured for an output voltage of 0.8V with reference to output A. Output B will never exceed output A by more than 0.8V but will be 3.3V with respect to ground when output A is at the specified 2.5V. Although a very small portion of the overall current, it should be noted that load connected to regulator A must sink the 10µA set pin current of regulator B.

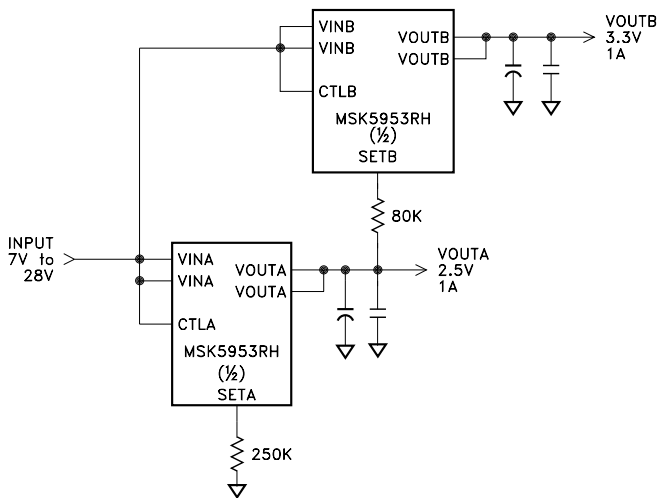

FIGURE 6

HEAT SINKING

To determine if a heat sink is required for your application and if so, what type, refer to the thermal model and governing equation below.

Governing Equation: $T_J = P_D \times (R_{\theta JC} + R_{\theta CS} + R_{\theta SA}) + T_A$

WHERE

T_J = Junction Temperature
 P_D = Total Power Dissipation
 $R_{\theta JC}$ = Junction to Case Thermal Resistance
 $R_{\theta CS}$ = Case to Heat Sink Thermal Resistance
 $R_{\theta SA}$ = Heat Sink to Ambient Thermal Resistance
 T_C = Case Temperature
 T_A = Ambient Temperature
 T_S = Heat Sink Temperature

EXAMPLE:

This example demonstrates the thermal calculations for the package with the regulator operating at one-half of its maximum rated output current.

Conditions for MSK5953RH:

$V_{IN} = +3.0V$; $I_{OUT} = +0.50A$ $V_{OUT} = +1.0V$

- 1.) Assume 45° heat spreading model.
- 2.) Find regulator power dissipation:

$$P_D = (V_{IN} - V_{OUT})(I_{OUT})$$

$$P_D = (3-1)(0.50)$$

$$= 1.0W$$

- 3.) For conservative design, set $T_J = +125^\circ C$ Max.
- 4.) For this example, worst case $T_A = +90^\circ C$.
- 5.) $R_{\theta JC} = 10.5^\circ C/W$ from the Electrical Specification Table.
- 6.) $R_{\theta CS} = 0.15^\circ C/W$ for most thermal greases.
- 7.) Rearrange governing equation to solve for $R_{\theta SA}$:

$$R_{\theta SA} = ((T_J - T_A)/P_D) - (R_{\theta JC}) - (R_{\theta CS})$$

$$= ((125^\circ C - 90^\circ C)/1.0W) - 10.5^\circ C/W - 0.15^\circ C/W$$

$$= 24.4^\circ C/W$$

In this case the result is 24.4°C/W. Therefore, a heat sink with a thermal resistance of no more than 24.4°C/W must be used in this application to maintain the regulator junction temperature under 125°C.

TOTAL DOSE RADIATION TEST PERFORMANCE

Radiation performance curves for TID testing have been generated for all radiation testing performed by TTM Technologies, Inc. These curves show performance trends throughout the TID test process and are located in the MSK5953RH radiation test report. The complete radiation test report is available in the RAD HARD PRODUCTS section on the TTM Technologies website.

ADDITIONAL APPLICATION INFORMATION

For additional applications information, please reference Linear Technology Corporation's® LT3080 and RH3080 data sheets.

TYPICAL PERFORMANCE CURVES

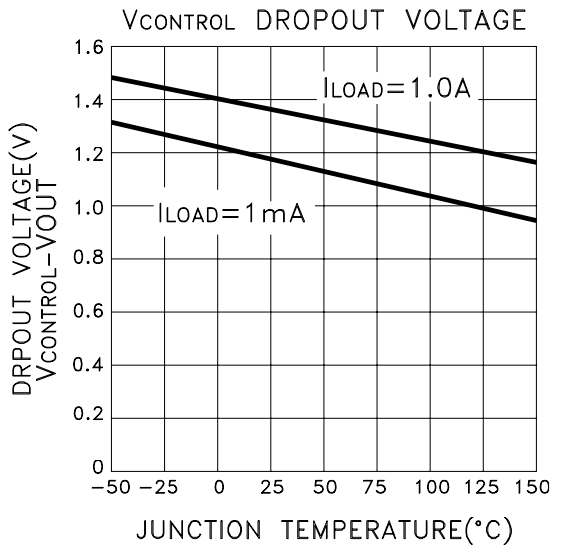
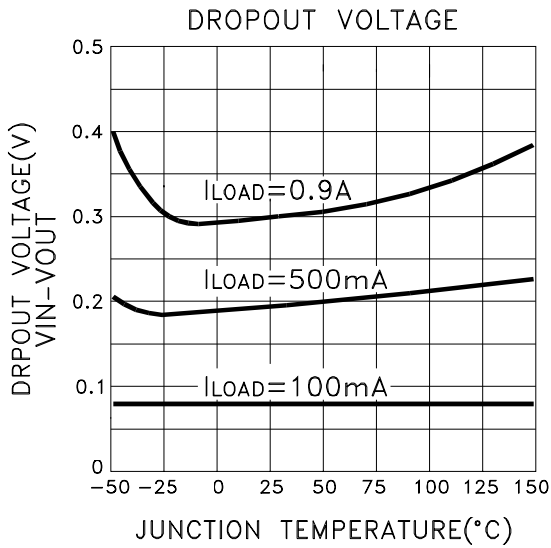
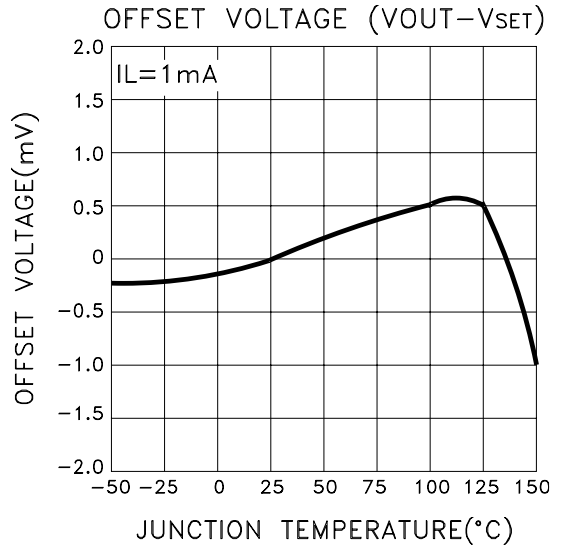
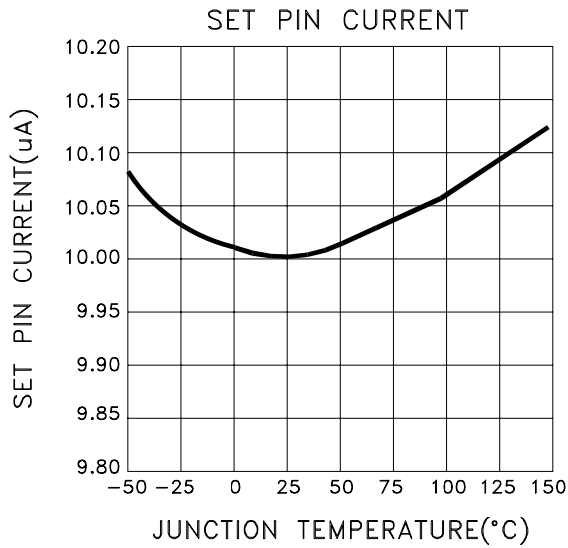

TYPICAL PERFORMANCE CURVES CONT'D

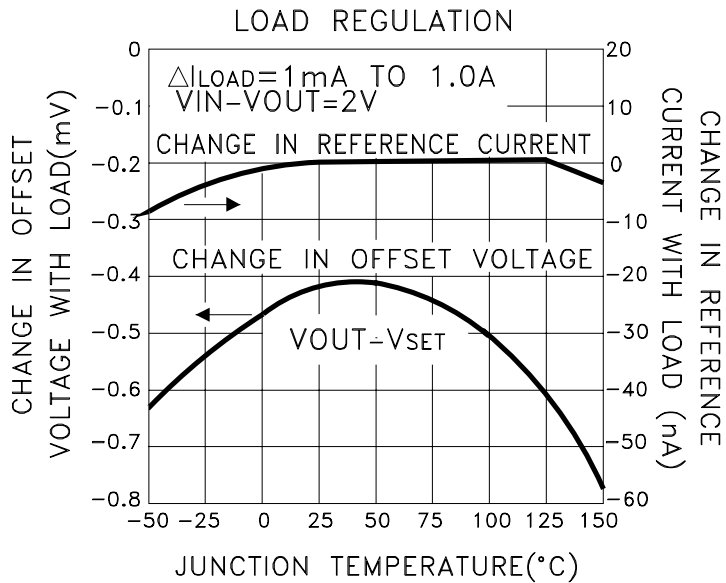
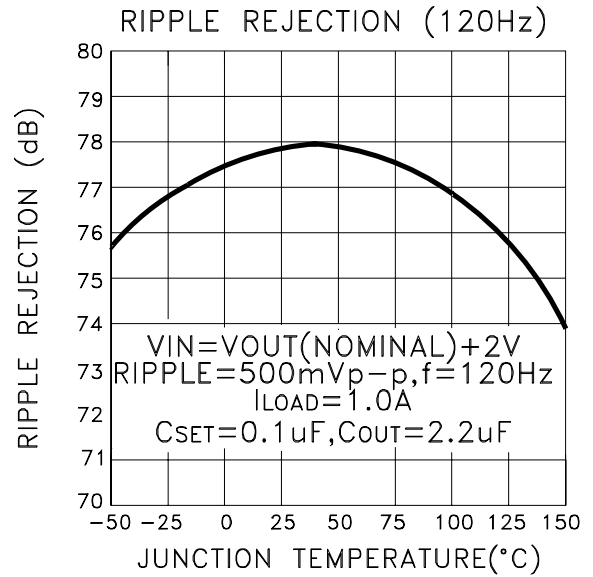
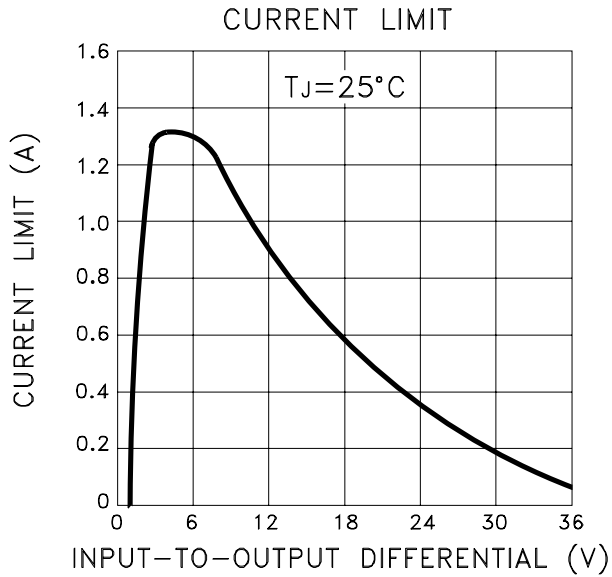

MECHANICAL SPECIFICATIONS

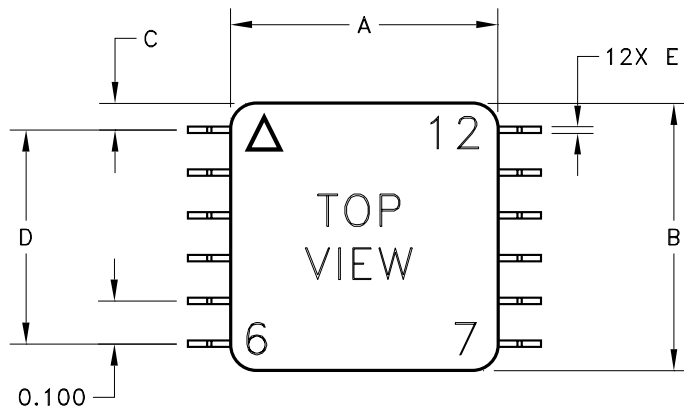

REF	MIN	MAX
A	0.620	0.630
B	0.620	0.630
C	0.0575	0.0675
D	0.495	0.505
E	0.012	0.018
F	0.007	0.013
G	0.045	0.055
H	0.045	0.055
I	0.720	0.730
J	0.820	0.830
K	0.015	0.019
K	0.012	0.018
L		0.160

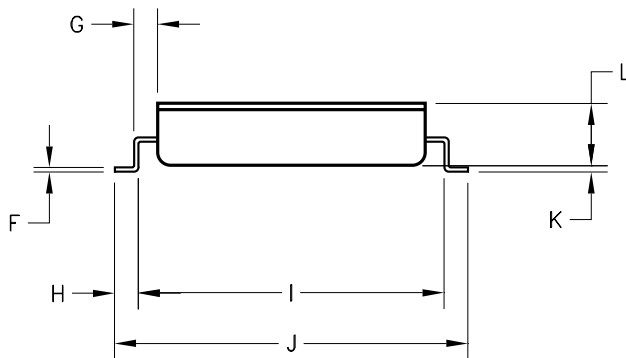

ESD TRIANGLE INDICATES PIN 1
WEIGHT=3.5 GRAMS TYPICAL

ALL DIMENSIONS ARE SPECIFIED IN INCHES

ORDERING INFORMATION

Part Number	Screening Level
MSK5953RH	INDUSTRIAL
MSK5953HRH	MIL-PRF-38534 CLASS H
MSK5953KRH	MIL-PRF-38534 CLASS K

REVISION HISTORY

REV	STATUS	DATE	DESCRIPTION
F	Released	04/14	Update conditions for electrical specifications and clarify mechanical specifications.
G	Released	10/14	Update max set pin current specifications.
H	Released	08/15	Add ESD rating to absolute maximum ratings, make correction to heat sinking example and front page description.
J	Released	04/22	Remove MIL-PRF-38535, update company name and website.

TTM Technologies
www.ttmtech.com

The information contained herein is believed to be accurate at the time of printing. TTM Technologies reserves the right to make changes to its products or specifications without notice, however and assumes no liability for the use of its products. Please visit our website for the most recent revision of this data sheet.