

Product Preview

CopperGold™ Line Driver

The MC03AX1456 CopperGold Line Driver provides a single chip companion device to interface the MC145650 CopperGold Transceiver to the line transformer.

The MC03AX1456CO is designed to fulfill the central office requirements. The MC03AX1456RT is optimized for use at the remote terminal (i.e., consumer premises). The CopperGold Line Driver provides three differential ports: a transmit and a receive port to interface to the CopperGold Transceiver's transmit and receive ports, respectively; and a bidirectional line port.

The transmit port incorporates a high-pass filter and a programmable gain stage with three settings. The receive port incorporates a programmable HF boost and a programmable gain stage, each with three settings, as well as a high pass-filter.

- Hybrid Balance for Echo Cancellation
- Defined Termination Impedance to the Line
- Programmable Transmit Gain (3 Settings)
- Programmable Receive Gain (3 Settings)
- Programmable HF Boost (3 Settings)
- Transmit Band for the CO is 26 kHz — 1104 kHz
- Transmit Band for the RT is 26 kHz — 138 kHz
- Frequency Ripple < 0.5 dB (CO and RT)
- Standby Mode for Lower Power Dissipation (CO and RT)
- ±15 V ±10% Supply Voltages
- 30-Pin HSOP Package
- Provides 20 dbm Drive for ATU-C

MC03AX1456CO
MC03AX1456RT

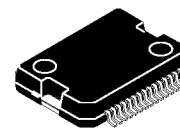

HSOP SUFFIX
PLASTIC PACKAGE
CASE 979A-02

COPPERGOLD SYSTEM BLOCK DIAGRAM

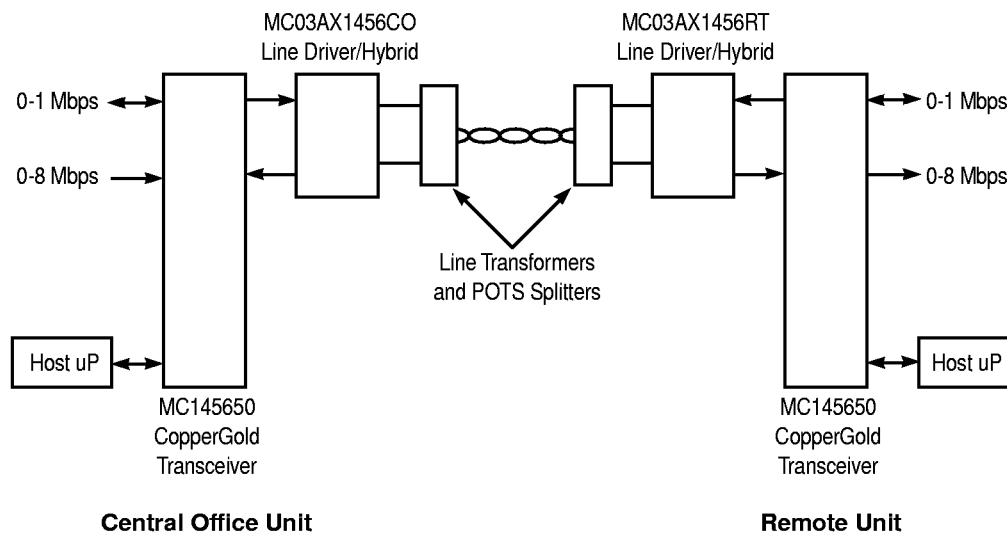

This document contains information on a product under development. Motorola reserves the right to change or discontinue this product without notice.

CopperGold is a trademark of Motorola, Inc. All brand names and product names appearing in this document are registered trademarks of their respective holders.

MAXIMUM RATINGS*

Symbol	Parameter	Value	Unit
V _{CC}	Positive Supply Voltage (Referenced to GND)	+ 18	V
V _{EE}	Negative Supply Voltage (Referenced to GND)	- 18	V
V _{IN}	Input Voltage (Referenced to GND)	TBD	V
V _{OUT}	Output Voltage (Referenced to GND)	TBD	V
I _{IN}	Input Current	TBD	mA
I _{OUT}	Output Current	TBD	mA
T _{STG}	Storage Temperature Range	- 65 to + 150	°C

*Maximum Ratings are those values beyond which damage to the device may occur. Functional operation should be restricted to the Recommended Operating Conditions.

RECOMMENDED OPERATING CONDITIONS

Symbol	Parameter	Min	Typ	Max	Unit
V _{CC}	Positive Supply Voltage	+ 13.5	+ 15.0	+ 16.5	V
V _{Sup}	Negative Supply Voltage	- 13.5	- 15.0	- 16.5	V
T _J	Junction Temperature			150	°C

PACKAGE DIMENSIONS

HSOP SUFFIX PLASTIC PACKAGE CASE 979A-02

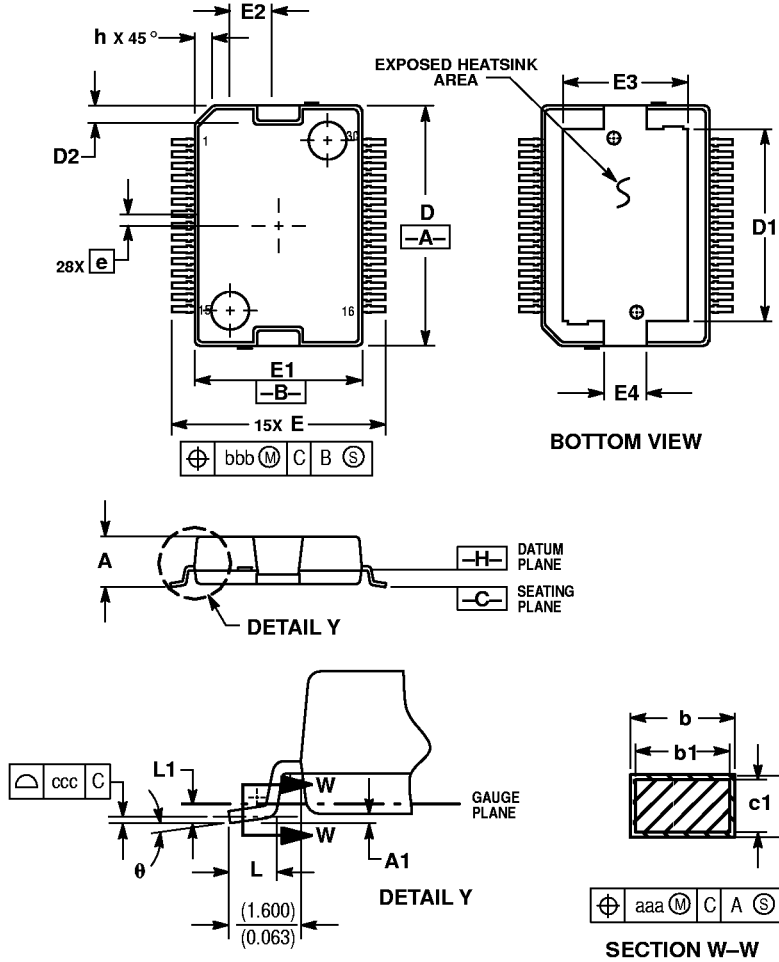

- NOTES:
1. DIMENSIONING AND TOLERANCING PER ANSI Y14.5M, 1982.
 2. CONTROLLING DIMENSION: MILLIMETER.
 3. DATUM PLANE -H- IS LOCATED AT BOTTOM OF LEAD AND IS COINCIDENT WITH THE LEAD WHERE THE LEAD EXITS THE PLASTIC BODY AT THE BOTTOM OF THE PARTING LINE.
 4. DIMENSIONS D AND E1 DO NOT INCLUDE MOLD PROTRUSION. ALLOWABLE PROTRUSION IS 0.150 (0.006) PER SIDE. DIMENSIONS D AND E1 DO INCLUDE MOLD MISMATCH AND ARE DETERMINED AT DATUM PLANE -H-.
 5. DIMENSION b DOES NOT INCLUDE DAMBAR PROTRUSION. ALLOWABLE DAMBAR PROTRUSION SHALL BE 0.127 (0.005) TOTAL IN EXCESS OF THE b DIMENSION AT MAXIMUM MATERIAL CONDITION.
 6. DATUMS -A- AND -B- TO BE DETERMINED AT DATUM PLANE -H-.

DIM	MILLIMETERS		INCHES	
	MIN	MAX	MIN	MAX
A	3.100	3.450	0.122	0.136
A1	0.050	0.200	0.002	0.008
A2	3.050	3.250	0.120	0.128
D	15.800	16.000	0.622	0.630
D1	12.270	12.470	0.483	0.491
D2	0.900	1.100	0.035	0.043
E	13.950	14.450	0.549	0.569
E1	10.900	11.100	0.429	0.437
E2	2.500	2.700	0.098	0.106
E3	7.000	7.200	0.276	0.284
E4	2.700	2.900	0.106	0.114
L	0.840	1.100	0.033	0.043
L1	0.350 BSC		0.014 BSC	
b	0.350	0.475	0.014	0.019
b1	0.350	0.432	0.014	0.017
c	0.230	0.320	0.009	0.013
c1	0.230	0.280	0.009	0.011
e	0.800 BSC		0.031 BSC	
h	—	1.100	—	0.043
θ	0°	8°	0°	8°
aaa	0.200		0.008	
bbb	0.200		0.008	
ccc	0.100		0.004	