

**LA7567B, 7567BM****TV and VCR VIF/SIF IF Signal-Processing Circuit with PAL/NTSC Multi-Format Audio Support****Overview**

The LA7567B and LA7567BM are PAL/NTSC multi-format audio VIF/SIF IF ICs that adopt a semi-adjustment-free system. The VIF block adopts a technique that makes AFT adjustment unnecessary by adjusting the VCO, thus simplifying the adjustment steps in the manufacturing process. PLL detection is adopted in the FM detector to support multi-format audio detection. A built-in SIF converter is included to simplify multi-format system designs. A 5-V power-supply voltage is used to match that used in most multimedia systems. In addition, these ICs also include a buzz canceller to suppress Nyquist buzz and provide high audio quality. The LA7567B and LA7567BM feature improvements over the LA7567N and LA7567NM in the audio and video signal-to-noise ratios and the video signal amplitude.

Functions

[VIF]

- VIF amplifier • PLL detector • BNC • RF AGC
- EQ amplifier • AFT • IF AGC • Buzz canceller

[First SIF]

- First SIF • First SIF detector • AGC

[SIF]

- Multi-format SIF converter • Limiter amplifier
- PLL FM detector

Features

- Both AFT and SIF inductors built in, thus making adjustment of external inductance unnecessary.
- A PAL/NTSC multi-format audio system can be constructed easily.
- Built-in buzz canceller for excellent audio performance.
- $V_{CC} = 5\text{ V}$, low power dissipation (250 mW)

Package Dimensions

unit: mm

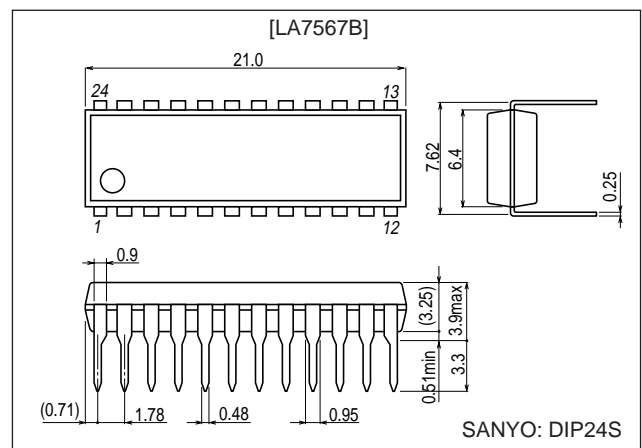
3067A-DIP24S

unit: mm

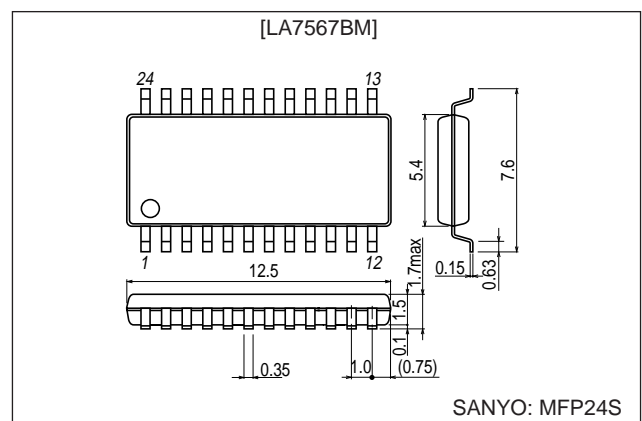
3112A-MFP24S

■ Any and all SANYO products described or contained herein do not have specifications that can handle applications that require extremely high levels of reliability, such as life-support systems, aircraft's control systems, or other applications whose failure can be reasonably expected to result in serious physical and/or material damage. Consult with your SANYO representative nearest you before using any SANYO products described or contained herein in such applications.

■ SANYO assumes no responsibility for equipment failures that result from using products at values that exceed, even momentarily, rated values (such as maximum ratings, operating condition ranges, or other parameters) listed in products specifications of any and all SANYO products described or contained herein.

LA7567B, 7567BM

Specifications

Maximum Ratings at $T_a = 25^\circ\text{C}$

Parameter	Symbol	Conditions	Ratings	Unit
Maximum supply voltage	V_{CC} max		6	V
Circuit voltage	V13, V17		V_{CC}	V
Circuit current	I6		-3	mA
	I10		-10	mA
	I24		-2	mA
Allowable power dissipation	Pd max	$T_a \leq 70^\circ\text{C}$, Independent IC : LA7567B	500	mW
		$T_a \leq 50^\circ\text{C}$, Independent IC : LA7567BM	420	mW
		*: Mounted on a printed circuit board	720	mW
Operating temperature	Topr		-20 to +70	$^\circ\text{C}$
Storage temperature	Tstg		-55 to +150	$^\circ\text{C}$

Note: When mounted on a $65 \times 72 \times 1.6$ mm paper/phenolic resin printed circuit board.

Operating Conditions at $T_a = 25^\circ\text{C}$

Parameter	Symbol	Conditions	Ratings	Unit
Recommended supply voltage	V_{CC}		5	V
Operating supply voltage range	V_{CC} op		4.5 to 5.5	V

Electrical Characteristics at $T_a = 25^\circ\text{C}$, $V_{CC} = 5\text{ V}$, $f_p = 38.9\text{ MHz}$

Parameter	Symbol	Conditions	Ratings			Unit
			min	typ	max	
[VIF Block]						
Circuit current	I5		40.8	48.0	55.2	mA
Maximum RF AGC voltage	V14H		$V_{CC} - 0.5$	V_{CC}		V
Minimum RF AGC voltage	V14L			0	0.5	V
Input sensitivity	V_{IN}	S1 = OFF	27	33	39	$\text{dB}\mu\text{V}$
AGC range	G_R	LA7567B	54	59		dB
		LA7567BM	58	63		
Maximum allowable input	V_{IN} max	LA7567B	92	97		$\text{dB}\mu\text{V}$
		LA7567BM	95	100		
No-signal state video output voltage	V6		2.7	3.0	3.3	V
Synchronizing signal tip voltage	V6 tip		0.4	0.7	1.0	V
Video output level	V_O		1.7	2.0	2.3	Vp-p
Black noise threshold voltage	V_{BTH}		0.5	0.8	1.1	V
Black noise clamp voltage	V_{BCL}		1.6	1.9	2.2	V
Video signal-to-noise ratio	S/N		48	52		dB
C-S beat	IC-S		38	43		dB
Frequency characteristics	f_C	6 MHz	-3.0	-1.5		dB
Differential gain	DG			3.0	6.5	%
Differential phase	DP			3	5	deg
No-signal state AFT voltage	V13		2.0	2.5	3.0	V
Maximum AFT voltage	V13H		4.0	4.4	5.0	V
Minimum AFT voltage	V13L		0	0.18	1.00	V
AFT detection sensitivity	Sf	LA7567B	16	23	30	mV/kHz
		LA7567BM	17	25	34	
VIF input resistance	R_i	38.9 MHz		1.5		$\text{k}\Omega$
VIF input capacitance	C_i	38.9 MHz		3		pF
APC pull-in range (U)	f_{PU}		0.7	1.5		MHz
APC pull-in range (L)	f_{PL}			-1.5	-0.9	MHz
AFT tolerance frequency 1	dfa1		-250	0	+200	kHz
VCO1 maximum variability range (U)	dfu		1.0	1.5		MHz
VCO1 maximum variability range (L)	dfL			-1.5	-1.0	MHz
VCO control sensitivity	B	LA7567B	1.3	2.6	5.2	kHz/mV
		LA7567BM	1.6	3.2	6.4	

Continued on next page.

LA7567B, 7567BM

Continued from preceding page.

Parameter	Symbol	Conditions	Ratings			Unit
			min	typ	max	
[First SIF Block]						
Conversion gain	VG	LA7567B	24	30	36	dB
		LA7567BM	22	28	32	
5.5 MHz output level	S _O	LA7567B	43	96	150	mVrms
		LA7567BM	32	70	110	
First SIF maximum input	S _{IN} max		50	100		mVrms
First SIF input resistance	R _{IN} (SIF)	33.4 MHz		2		kΩ
First SIF input capacitance	C _{IN} (SIF)	33.4 MHz		3		pF
[SIF Block]						
Limiting sensitivity	V _{li} (lim)		42	48	54	dBμV
FM detector output voltage	V _O (FM)	5.5 MHz ±30 kHz *: LA7567B	410	580	750	mVrms
		5.5 MHz ±30 kHz *: LA7567BM	470	600	760	
AMR rejection ratio	AMR		50	60		dB
Total harmonic distortion	THD			0.3	0.8	%
SIF S/N	S/N (FM)		57	62		
[SIF Converter]						
Conversion gain	VG (SIF)		8	11	14	dB
Maximum output level	V max		103	109	115	dBμV
Carrier suppression ratio	VGR (5.5)		15	21		dB
Oscillator level	V _{OSC}		35	70		mVp-p
Oscillator leakage	OSCleak		14	25		dB
Oscillator stopped current	I ₄				300	μA

Note: *The FM detector output level can be reduced and the FM dynamic range can be increased by inserting a resistor and a capacitor in series between pin 23 and ground.

Pin Assignment

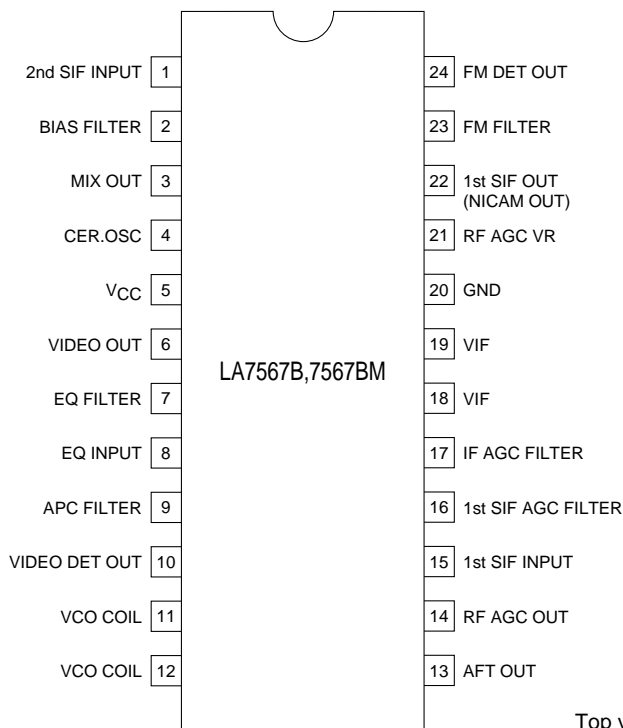

Top view

A12027

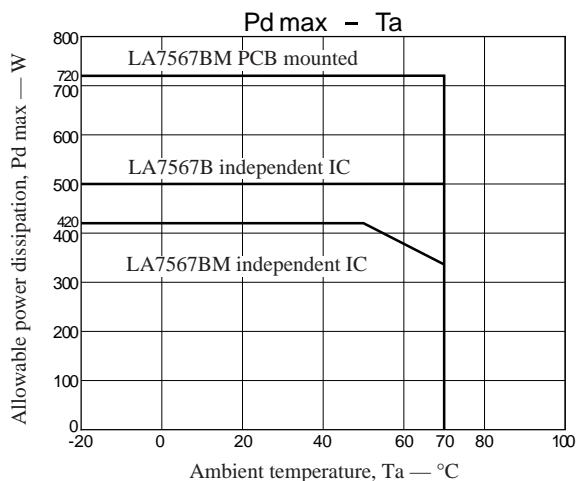

LA7567B, 7567BM

Application Circuit Diagrams

PAL SPLIT

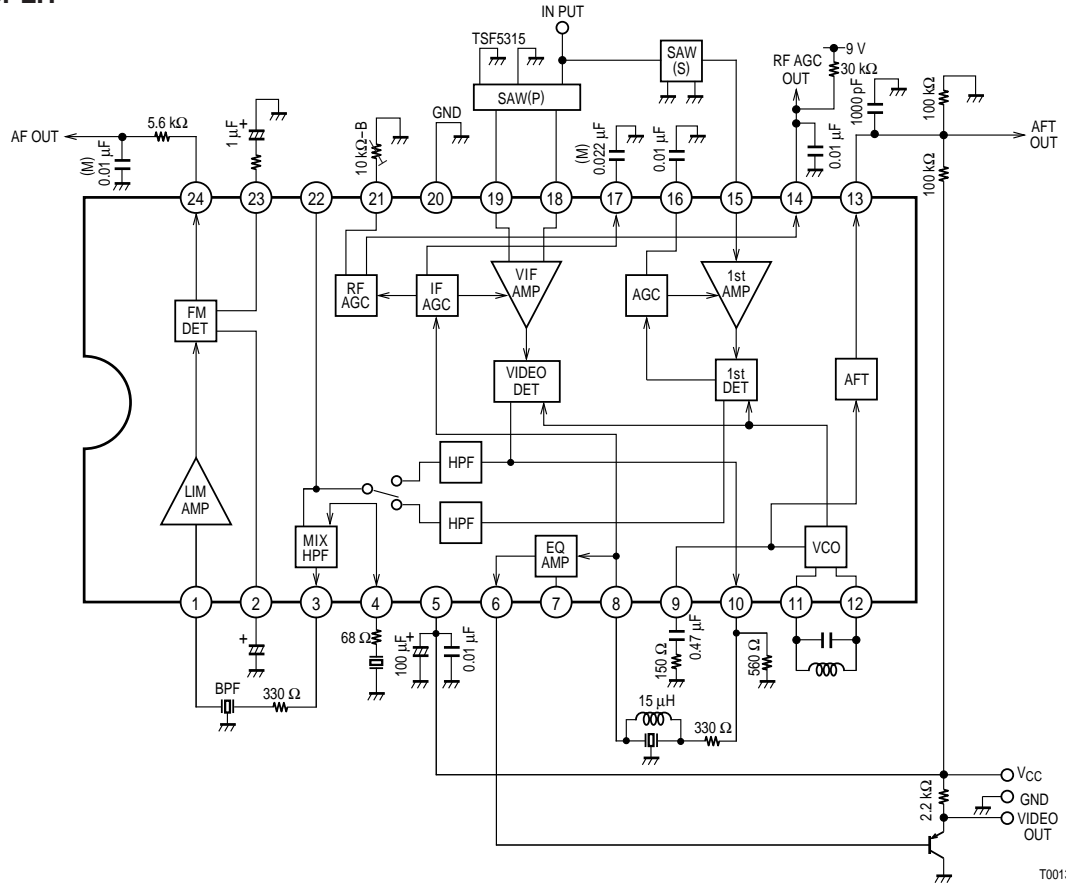

T00137

NT (US) SPLIT

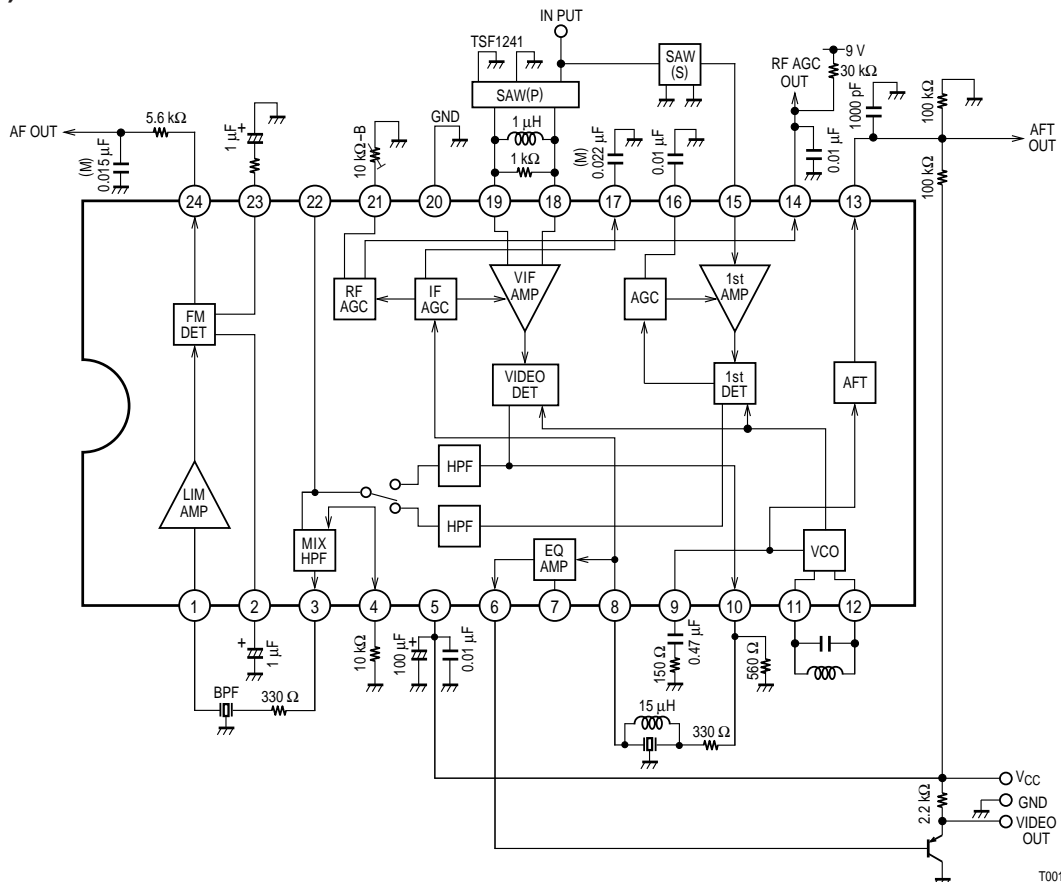

T00138

LA7567B, 7567BM

Sample Application Circuit

When the SIF, first SIF, AFT, and RF AGC circuits are not used:

- When the SIF circuit is not used:
 Leave pins 1, 23, and 24 open.
 Connect pin 2 to ground through a 2-k Ω resistor.
- When the first SIF circuit is not used:
 Leave pins 3, 4, 15 and 22 open.
 Connect pin 16 to ground.
- When the AFT circuit is not used:
 Since there is no way to defeat the AFT circuit, connect a 100-k Ω resistor and a 0.01- μ F capacitor in parallel between pin 13 and ground.
- When the RF AGC circuit is not used:
 Leave pins 14 and 21 open.
 Insert a 0.01- μ F capacitor between pin 21 and ground for oscillation prevention.

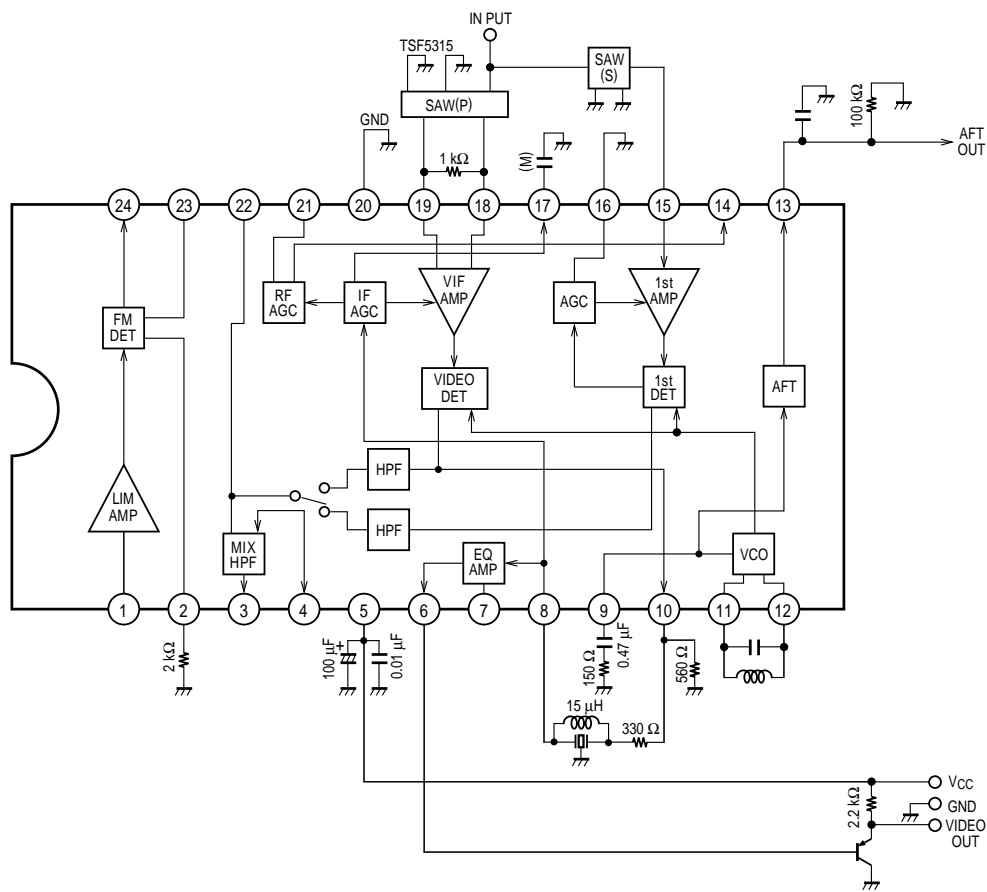

T00141

LA7567B, 7567BM

Pin Descriptions

Pin No.	Pin	Description	Equivalent circuit
1	SIF INPUT	<ul style="list-style-type: none"> SIF input. The input impedance is about 1 kΩ. Since buzzing and buzz beating can occur if interference enters this input pin, care must be taken when design the pattern layout for this pin. Note that the video and chrominance signals are especially likely to interfere with the audio signal. Also, the VIF carrier signal can also cause interference. 	
2	FM power supply filter	<ul style="list-style-type: none"> FM detector bias line filter input. Used to improve the FM detector signal-to-noise ratio. C1 should be at least 0.47 μF, and 1 μF is recommended. If the FM detector is not used, connect pin 2 to ground through a 2-kΩ resistor. This stops the FM detector VCO. 	
3 4	SIF converter	<ul style="list-style-type: none"> Pin 3 is the SIF converter output. The signal is passed through a 6-MHz bandpass filter and input to the SIF circuit. There is a 200-Ω resistor in series with the emitter-follower output. Pin 4 is the SIF converter 500-kHz oscillator connection. Since this oscillator circuit includes an ALC, the oscillator level is held fixed at a low level. If this circuit is not used, connect pin 4 to ground through a 10-kΩ external resistor. Providing this external resistor stops the 500-kHz oscillator and allows the converter to be used as an amplifier. 	
5	V_{CC}	<ul style="list-style-type: none"> Use the shortest distance possible when decoupling V_{CC} and ground. 	

Continued on next page.

LA7567B, 7567BM

Continued from preceding page.

Pin No.	Pin	Description	Equivalent circuit
6 7 8	EQ amp	<ul style="list-style-type: none"> • Equalizer circuit. This circuit is used to correct the video signal frequency characteristics. Pin 8 is the EQ amplifier input. This amplifier amplifies a 1.5-V p-p video signal to 2-V p-p. • Notes on equalizer amplifier design The equalizer amplifier is designed as a voltage follower amplifier with a gain of about 2.3 dB. When used for frequency characteristics correction, a capacitor, inductor, and resistor must be connected in series between pin 7 and ground. • Approach used in the equalizer amplifier If v_i is the input signal and v_o is the output signal, then: $\frac{R_1}{2} + 1 (v_i + v_{in}) = V_o \times G$ <p>Where G is the voltage-follower amplifier gain. Assume: v_{in}: Imaginary short G: About 2.3 dB $v_{in} \approx 0$. Then: $AV = \frac{v_o G}{v_i} = \frac{R_1}{Z} + 1$</p> <ul style="list-style-type: none"> • R1 is the IC internal resistance, and is 1 kΩ. In the application design, simply select Z to correspond to the desired characteristics. However, since the EQ amplifier gain will be maximum at the resonant point defined by Z, care is required to assure that distortion does not occur. 	<p style="text-align: right; font-size: small;">A12032</p>
9	APC FILTER	<ul style="list-style-type: none"> • PLL detector APC filter connection. The APC time constant is switched internally in the IC. When locked, the VCO is controlled by loop A and the loop gain is reduced. When unlocked and during weak field reception, the VCO is controlled by loop B and the loop gain is increased. <p>For this APC filter we recommend: R = 150 to 390 Ω C = 0.47 μF</p>	<p style="text-align: right; font-size: small;">A12034</p>

Continued on next page.

LA7567B, 7567BM

Continued from preceding page.

Pin No.	Pin	Description	Equivalent circuit
10	Composite video output	<ul style="list-style-type: none"> Output for the video signal that includes the SIF carrier. A resistor must be inserted between pin 10 and ground to acquire adequate drive capability. $R \geq 300 \Omega$ 	<p style="text-align: right; font-size: small;">A12035</p>
11 12	VCO tank	<ul style="list-style-type: none"> VCO tank circuit used for video signal detection. See the coil specifications provided separately for details on the tank circuit. This VCO is a vector synthesis VCO. 	<p style="text-align: right; font-size: small;">A12036</p>
13	AFT OUTPUT	<ul style="list-style-type: none"> AFT output. The AFT center voltage is generated by an external bleeder resistor. The AFT gain is increased by increasing the resistance of this external bleeder resistor. However, this resistor must not exceed 390 kΩ. This circuit includes a control function that controls the AFT voltage to naturally approach the center voltage during weak field reception. 	<p style="text-align: right; font-size: small;">A12037</p>
14	RF AGC OUTPUT	<ul style="list-style-type: none"> RF AGC output. This output controls the tuner RF AGC. A protective 100-Ω resistor is inserted in series with the open collector output. Determine the external bleeder resistor value in accordance with the specifications of the tuner. 	<p style="text-align: right; font-size: small;">A12038</p>
15	1st SIF INPUT	<ul style="list-style-type: none"> First SIF input. A DC cut capacitor must be used in the input circuit. If a SAW filter is used: The first SIF sensitivity can be increased by inserting an inductor between the SAW filter and the IC to neutralize the SAW filter output capacitance and the IC input capacitance. When used in an intercarrier system: This pin (pin 15) may be left open. 	<p style="text-align: right; font-size: small;">A12039</p>

Continued on next page.

LA7567B, 7567BM

Continued from preceding page.

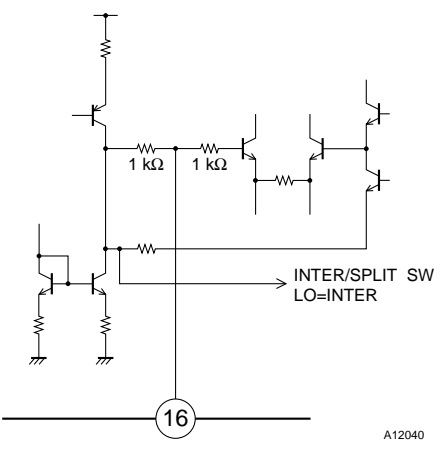
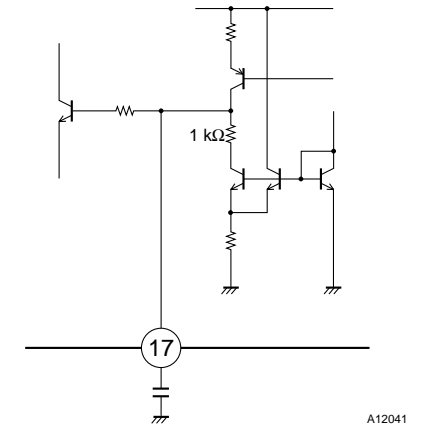
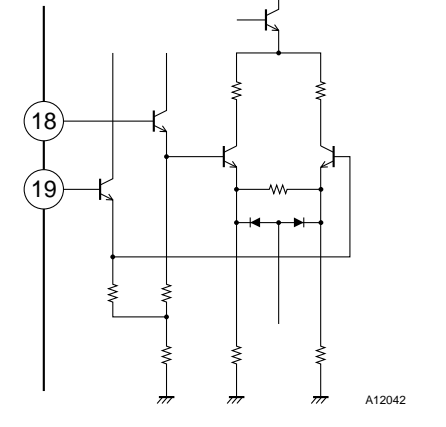
Pin No.	Pin	Description	Equivalent circuit
16	1st SIF AGC FILTER	<ul style="list-style-type: none"> • First SIF AGC filter connection. This IC adopts an average value AGC technique. The first SIF conversion gain is about 30 dB, and the AGC range is over 50 dB. A 0.01 μF capacitor is normally used in filter connected to this pin. • When used in an intercarrier system: Connect this pin (pin 16) to ground. The IC internal switch will operate to connect the intercarrier output to the SIF converter input. 	 <p style="text-align: right; font-size: small;">A12040</p>
17	IF AGC FILTER	<ul style="list-style-type: none"> • IF AGC filter connection The signal peak-detected by the built-in AGC detector is converted to the AGC voltage at pin 17. Additionally, a second AGC filter (a lag-lead filter) used to create the dual time constants is provided internally in the IC. Use a 0.022-μF capacitor as the external capacitor, and adjust the value according to the sag, AGC speed, and other characteristics. 	 <p style="text-align: right; font-size: small;">A12041</p>
18 19	VIF input	<ul style="list-style-type: none"> • VIF amplifier input. The input circuit is a balanced circuit, and the input circuit constants are: R = 1.5 kΩ C = 3 pF 	 <p style="text-align: right; font-size: small;">A12042</p>
20	GND		

Continued on next page.

LA7567B, 7567BM

Continued from preceding page.

Pin No.	Pin	Description	Equivalent circuit
21	RF AGC VR	<ul style="list-style-type: none"> RF AGC VR connection. This pin sets the tuner RF AGC operating point. Also, the FM output and the video output can both be muted at the same time by connecting this pin to ground. 	<p style="text-align: right; font-size: small;">A12043</p>
22	NICAM output	<ul style="list-style-type: none"> First SIF output. Internally, this is an emitter-follower output with a 600-Ω resistor attached. When used in an intercarrier system, the buzz characteristics can be improved by forming a chrominance carrier trap with this pin. <div style="text-align: center;"> <p>← Forms a chrominance killer trap.</p> <p style="font-size: x-small;">A12044</p> </div>	<p style="text-align: right; font-size: small;">A12045</p>
23	FM filter	<ul style="list-style-type: none"> Connection for a filter used to hold the FM detector output DC voltage fixed. Normally, a 1-μF electrolytic capacitor should be used. The capacitance should be increased if the low band (around 50 Hz) frequency characteristics need to be improved. The FM detector output level can be reduced and the FM dynamic range can be increased by inserting a resistor and a capacitor in series between pin 23 and ground. 	<p style="text-align: right; font-size: small;">A12045</p>
24	FM Detector output	<ul style="list-style-type: none"> Audio FM detector output. A 300-Ω resistor is inserted in series with an emitter-follower output. For applications that support stereo: Applications that input this signal to a stereo decoder may find that the input impedance is reduced, the left and right signals are distorted, and that the stereo characteristics are degraded. If this problem occurs, add a resistor between pin 24 and ground. $R1 \geq 5.1 \text{ k}\Omega$ For applications that support mono: Create an external deemphasis circuit. $t = C \times R2$ 	<p style="text-align: right; font-size: small;">A12046</p>

LA7567B, 7567BM

Notes on Sanyo SAW Filters

There are two types of SAW filters, which differ in the piezoelectric substrate material, as follows:

- Lithium tantalate (LiTaO₃) SAW filter

TSF11□□ ... Japan

TSF12□□ ... US

Although lithium tantalate SAW filters have the low temperature coefficient of $-18 \text{ ppm}/^\circ\text{C}$, they suffer from a large insertion loss. However, it is possible, at the cost of increasing the number of external components required, to minimize this insertion loss by using a matching circuit consisting of coils and other components at the SAW filter output. At the same time as minimizing insertion loss, this technique also allows the frequency characteristics, level, and other aspects to be varied, and thus provides increased circuit design flexibility. Also, since the SAW filter reflected wave level is minimal, the circuit can be designed with a small in-band ripple level.

- Lithium niobate (LiNbO₃) SAW filter

TSF52□□ ... US

TSF53□□ ... PAL

Although lithium niobate SAW filters have the high temperature coefficient of $-72 \text{ ppm}/^\circ\text{C}$, they feature an insertion loss about 10 dB lower than that of lithium tantalate SAW filters. Accordingly, there is no need for a matching circuit at the SAW filter output. Although the in-band ripple is somewhat larger than with lithium tantalate SAW filters, since they have a low impedance and a small field slew, they are relatively immune to influences from peripheral circuit components and the geometry of the printed circuit board pattern. This allows stable out-of-band trap characteristics to be acquired. Due to the above considerations, lithium tantalate SAW filters are used in applications for the US and Japan that have a high IF frequency, and lithium niobate SAW filters are used in PAL and US applications that have a low IF frequency.

Notes on SAW Filter Matching

In SAW filter input circuit matching, rather than matching the IF frequency, flatter video band characteristics can be acquired by designing the tuning point to be in the vicinity of the audio carrier rather than near the chrominance carrier. The situation shown in figure on the right makes it easier to acquire flat band characteristics than that in figure on the left.

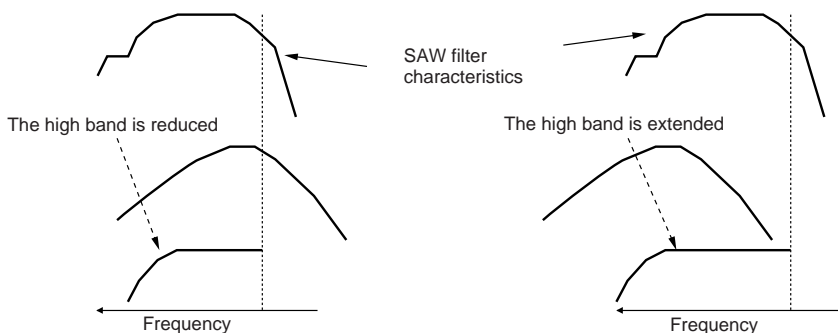

With the Tuning Set to the IF frequency

With the Tuning Set to the Vicinity of S and C

Coil Specifications

	JAPAN $f = 58.75 \text{ MHz}$	US $f = 45.75 \text{ MHz}$	PAL $f = 38.9 \text{ MHz}$
VCO coil	<p style="text-align: center;">A12048</p> <p style="text-align: center;">Test production no. V291XCS-3220Z Toko Co., Ltd.</p>	<p style="text-align: center;">A12049</p> <p style="text-align: center;">Test production no. 291XCS-3188Z Toko Co., Ltd.</p>	<p style="text-align: center;">A12050</p> <p style="text-align: center;">Test production no. 292GCS-7538Z Toko Co., Ltd.</p>
SAW filter (SPLIT)	<p style="text-align: center;">Picture TSF1137U Sound</p>	<p style="text-align: center;">Picture TSF1241 Sound</p>	<p style="text-align: center;">Picture TSF5315 Sound</p>
SAW filter (INTER)		<p style="text-align: center;">TSF5220 TSF5221</p>	<p style="text-align: center;">TSF5321 TSF5344</p>

Toko Co., Ltd. 2-1-17 Higashi-yukigaya, Ohta-ku, Tokyo, Japan
TEL: +81-3-3727-1167

LA7567B, 7567BM

Notes on VCO Tank Circuits

- Built-in capacitor VCO tank circuits

When the power is turned on, the heat generated by the IC is transmitted through the printed circuit board to the VCO tank circuit. At this point, the VCO coil frame functions as a heat sink and the IC heat is dissipated. As a result, it becomes more difficult to transmit heat to the VCO tank circuit's built-in capacitor, and the influence of drift at power on is reduced. Therefore, it suffices to design the circuit so that the coil and capacitor thermal characteristics cancel. Ideally, it is better to use a coil with a core material that has low temperature coefficient characteristics.

- External capacitor VCO tank circuits

When an external capacitor is used, heat generated by the IC is transmitted through the printed circuit board directly to the VCO tank circuit external capacitor. While this capacitor is heated relatively early after the power is turned on, the coil is not so influenced as much by this heat, and as a result the power-on drift is increased. Accordingly, a coil whose core material has low temperature coefficient characteristics must be used. It is also desirable to use a capacitor with similarly low temperature coefficient characteristics.

Note: Applications that use an external capacitor here must use a chip capacitor. If an ordinary capacitor is used, problems such as the oscillator frequency changing with the capacitor orientation may occur.

- Specifications of any and all SANYO products described or contained herein stipulate the performance, characteristics, and functions of the described products in the independent state, and are not guarantees of the performance, characteristics, and functions of the described products as mounted in the customer's products or equipment. To verify symptoms and states that cannot be evaluated in an independent device, the customer should always evaluate and test devices mounted in the customer's products or equipment.
- SANYO Electric Co., Ltd. strives to supply high-quality high-reliability products. However, any and all semiconductor products fail with some probability. It is possible that these probabilistic failures could give rise to accidents or events that could endanger human lives, that could give rise to smoke or fire, or that could cause damage to other property. When designing equipment, adopt safety measures so that these kinds of accidents or events cannot occur. Such measures include but are not limited to protective circuits and error prevention circuits for safe design, redundant design, and structural design.
- In the event that any or all SANYO products (including technical data, services) described or contained herein are controlled under any of applicable local export control laws and regulations, such products must not be exported without obtaining the export license from the authorities concerned in accordance with the above law.
- No part of this publication may be reproduced or transmitted in any form or by any means, electronic or mechanical, including photocopying and recording, or any information storage or retrieval system, or otherwise, without the prior written permission of SANYO Electric Co., Ltd.
- Any and all information described or contained herein are subject to change without notice due to product/technology improvement, etc. When designing equipment, refer to the "Delivery Specification" for the SANYO product that you intend to use.
- Information (including circuit diagrams and circuit parameters) herein is for example only; it is not guaranteed for volume production. SANYO believes information herein is accurate and reliable, but no guarantees are made or implied regarding its use or any infringements of intellectual property rights or other rights of third parties.

This catalog provides information as of April 2003. Specifications and information herein are subject to change without notice.