

Document No.	853-0657
ECN No.	99799
Date of Issue	June 14, 1990
Status	Product Specification
ECL Products	

10124 Translator

Quad TTL-to-ECL Translator

FEATURES

- Typical propagation delay: 3.5ns
- Typical supply current ($-I_{EE}$): 53mA

DESCRIPTION

The 10124 is a Quad TTL-ECL Translator with an individual Data and Common Select TTL-compatible input on each gate. When the Select input is in the LOW State, all ECL non-inverting outputs are in a LOW State and inverting outputs are in a HIGH State.

ORDERING INFORMATION

DESCRIPTION	ORDER CODE
16-Pin Plastic DIP	10124N
16-Pin Ceramic DIP	10124F
16-Pin SO	10124D

PIN DESCRIPTION

PINS	DESCRIPTION
$D_0 - D_3$	Data Inputs (Schottky TTL)
S	Select Input (Schottky TTL)
Q_1, Q_3, Q_5, Q_7	Data Outputs (AND) (10K ECL)
$\bar{Q}_0, \bar{Q}_2, \bar{Q}_4, \bar{Q}_6$	Data Outputs (NAND) (10K ECL)

PIN CONFIGURATION

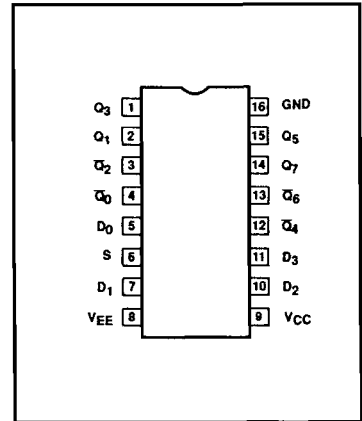

LOGIC DIAGRAM

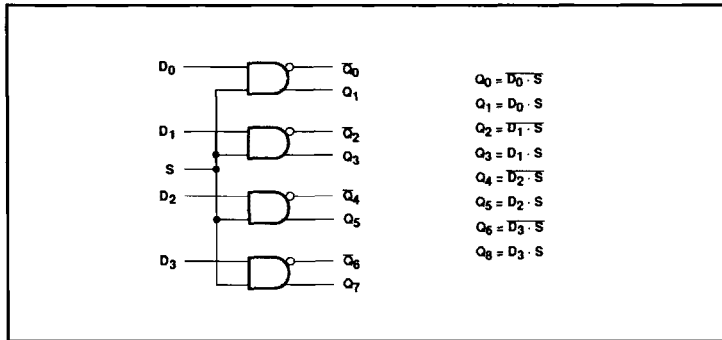

Translator

10124

SIMPLIFIED SCHEMATIC

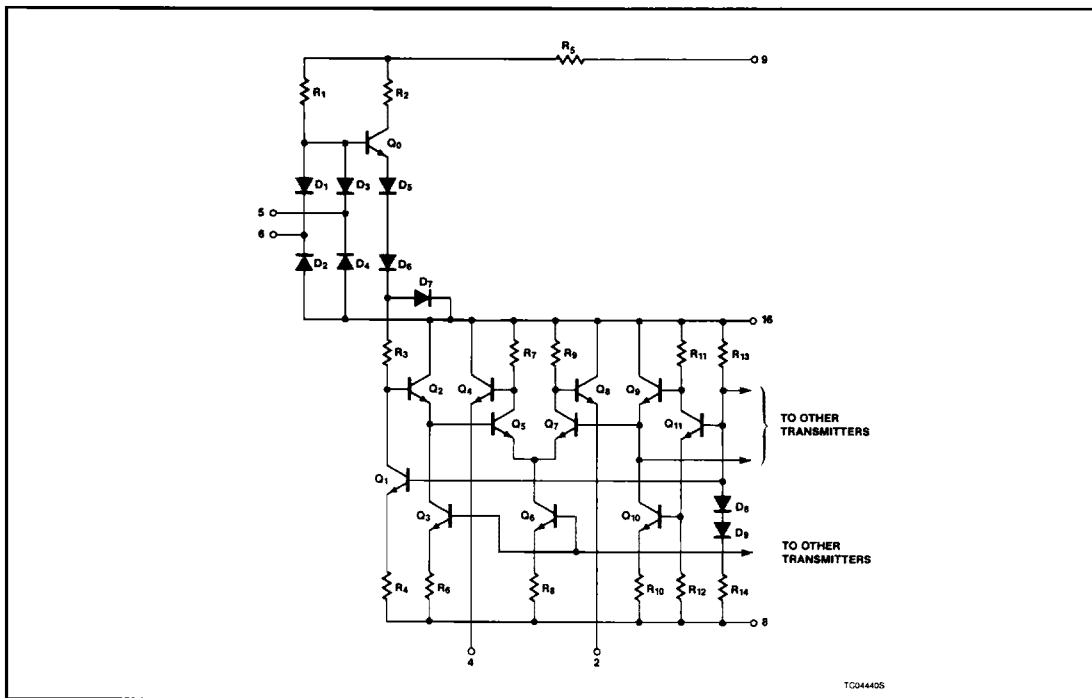

ABSOLUTE MAXIMUM RATINGS

SYMBOL	PARAMETER	LIMITS	UNIT	
V_{EE}	Supply voltage (negative)	-8.0	V	
V_{CC}	Supply voltage (positive)	+7.0	V	
V_{IN}	Input voltage	0 to V_{CC}	V	
I_{IN}	Input current	-30 to +5.0	mA	
I_O	Output source current (continuous)	-50	mA	
T_S	Storage temperature range	-55 to +150	°C	
T_J	Maximum junction temperature	Ceramic Package	+165	°C
		Plastic Package	+150	°C

NOTE:

Operation beyond the limits set forth in this table may impair the useful life of the device. Unless otherwise noted, these limits are specified over the operating ambient temperature range.

Translator

10124

DC OPERATING CONDITIONS

SYMBOL	PARAMETER	TEST CONDITIONS	LIMITS			UNIT
			MIN.	NOM.	MAX.	
GND	Device ground (common)		0	0	0	V
V _{CC}	Supply voltage (positive)			5.0		V
V _{EE}	Supply voltage (negative)			-5.2		V
V _{IH}	High level input voltage	T _A = -30°C	2.0		4.0	V
		T _A = +25°C	1.8		4.0	V
		T _A = +85°C	1.8		4.0	V
V _{IHT}	High level input threshold voltage	T _A = -30°C	2.0			V
		T _A = +25°C	1.8			V
		T _A = +85°C	1.8			V
V _{ILT}	Low level input threshold voltage	T _A = -30°C			1.1	V
		T _A = +25°C			1.1	V
		T _A = +85°C			0.9	V
V _{IL}	Low level input voltage	T _A = -30°C	0.4		1.1	V
		T _A = +25°C	0.4		1.1	V
		T _A = +85°C	0.4		0.8	V
T _A	Operating ambient temperature range		-30	+25	+85	°C

NOTE:

When operating at other than the specified V_{EE} voltage (-5.2V), the DC and AC Electrical Characteristics will vary slightly from specified values.

Translator

10124

DC ELECTRICAL CHARACTERISTICS GND = ground, $V_{CC} = +5.0V \pm 0.010V$, $V_{EE} = -5.2V \pm 0.010V$, $T_A = -30^\circ\text{C}$ to $+85^\circ\text{C}$ output loading 50Ω to $-2.0V \pm 0.010V$ unless otherwise specified^{1,3}

SYMBOL	PARAMETER	TEST CONDITIONS ²		LIMITS			UNIT
				MIN.	TYP.	MAX.	
V_{OH}	High level output voltage	$T_A = -30^\circ\text{C}$	For Q_n outputs, apply V_{IHMAX}	-1060		-890	mV
		$T_A = +25^\circ\text{C}$	to all inputs. For \bar{Q}_n outputs apply	-960		-810	mV
		$T_A = +85^\circ\text{C}$	V_{ILMIN} to all inputs.	-890		-700	mV
V_{OHT}	High level output threshold voltage	$T_A = -30^\circ\text{C}$	For Q_n outputs, apply V_{IHT} to D_1 input with	-1080			mV
		$T_A = +25^\circ\text{C}$	V_{IHMAX} applied to all other inputs. For \bar{Q}_n outputs, apply V_{ILT} to D_1 input with V_{IHMAX} applied to	-980			mV
		$T_A = +85^\circ\text{C}$	all other inputs.	-910			mV
V_{OLT}	Low level output threshold voltage	$T_A = -30^\circ\text{C}$	For Q_n outputs, apply V_{ILT} to D_1 input with			-1655	mV
		$T_A = +25^\circ\text{C}$	V_{IHMAX} applied to all other inputs. For \bar{Q}_n outputs, apply V_{IHT} to D_1 input with V_{IHMAX} applied to			-1630	mV
		$T_A = +85^\circ\text{C}$	all other inputs.			-1595	mV
V_{OL}	Low level output voltage	$T_A = -30^\circ\text{C}$	For Q_n outputs, apply V_{ILMIN}	-1890		-1675	mV
		$T_A = +25^\circ\text{C}$	to all inputs. For \bar{Q}_n outputs apply	-1850		-1650	mV
		$T_A = +85^\circ\text{C}$	V_{IHMAX} to all inputs.	-1825		-1615	mV
$-I_{EE}$	V_{EE} supply current	$T_A = -30^\circ\text{C}$	Apply V_{IHMAX} to all inputs.			72	mA
		$T_A = +25^\circ\text{C}$			53	66	mA
		$T_A = +85^\circ\text{C}$				72	mA
$\frac{\Delta V_{OH}}{\Delta V_{EE}}$	High level output voltage compensation	$T_A = +25^\circ\text{C}$			0.016		V/V
$\frac{\Delta V_{OL}}{\Delta V_{EE}}$	Low level output voltage compensation				0.250		V/V
$\frac{\Delta V_{BB}}{\Delta V_{EE}}$	Reference bias voltage compensation				0.148		V/V
V_{IK}	Clamp input voltage	S input	Apply -20mA to S input.			-1.5	V
		other inputs	Apply -10mA to each input under test, one at a time.			-1.5	
V_{BIN}	Input breakdown voltage	Apply 1.0mA to each input under test, one at a time		5.5			V
I_F	Forward current	S input	Apply VF(0.4.0V) to S input and VR(2.4V) to all other inputs.			-12.8	mA
		other inputs	Apply VF(0.4.0V) to each input under test, one at a time, with VR(2.4V) applied to all other inputs.			-3.2	mA
I_R	Reverse current	S input	Apply VR(2.4V) to S input with VF(0.4V) to all other inputs.			200	μA
		other inputs	Apply VR(2.4V) to each input under test, one at a time, with VF(0.4V) applied to all other inputs.			50	μA
I_{CCH}	High level output voltage	$T_A = -30^\circ\text{C}$	Apply V_{IHMAX} to all inputs.			16	mA
		$T_A = +25^\circ\text{C}$				16	mA
		$T_A = +85^\circ\text{C}$				18	mA
I_{CCL}	Supply current Low (positive)	Ground all inputs.				25	mA

NOTES:

- The specified limits represent the worst case values for the parameter. Since these worst case values normally occur at the supply voltage and temperature extremes, additional noise immunity can be achieved by decreasing the allowable operating condition ranges.
- Conditions for testing shown in the tables are not necessarily worst case. For worst case testing guidelines, refer to DC Testing, Chapter 1, Section 3.
- The specified limits shown in the DC Electrical Characteristics table can be met only after thermal equilibrium has been established. Thermal equilibrium is established by applying power for at least 2 minutes, while maintaining transverse airflow of 2.5 meters/sec (500 linear feet/min) over the device, mounted either in a test socket or on a printed circuit board. Test voltage values are given in the DC Operating Conditions table.

Translator

10124

TRANSFER CHARACTERISTICS

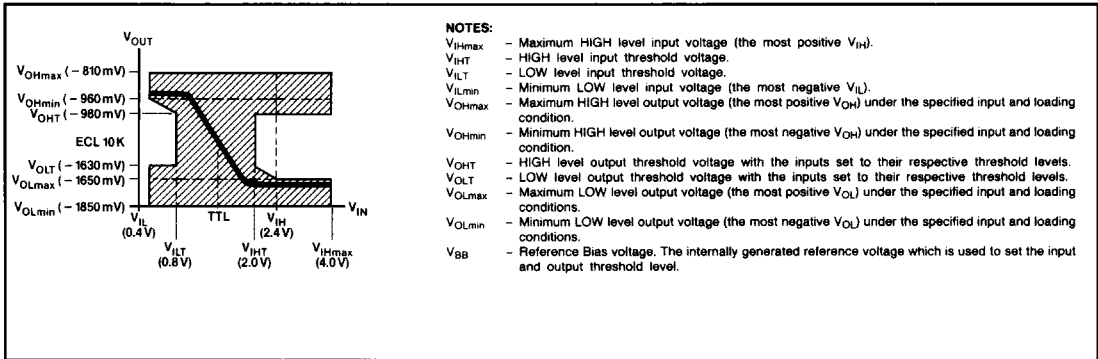

AC ELECTRICAL CHARACTERISTICS GND = ground, $V_{CC} = 5.0V \pm 0.010V$, $V_{EE} = -5.2V \pm 0.010V$

SYMBOL	PARAMETER	TEST CONDITION	LIMITS						UNIT	
			$T_A = -30^\circ C$		$T_A = +25^\circ C$		$T_A = +85^\circ C$			
			MIN.	MAX.	MIN.	TYP.	MAX.	MIN.		MAX.
t_{PLH} t_{PHL}	Propagation delay D_n to Q_n , \bar{Q}_n	Waveform 1	1.00	6.50	1.00	3.50	6.00	1.00	6.50	ns
t_{TLH} t_{THL}	Transition time 20% to 80%, 80% to 20%		1.30	4.10	1.30	2.50	3.90	1.30	4.10	ns

NOTE:

For AC test setup information, see AC Testing, Chapter 2, Section 3.

AC WAVEFORMS

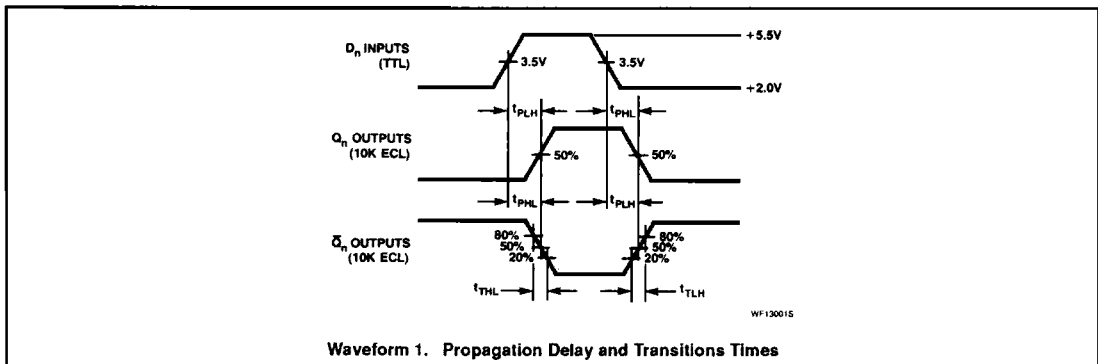

Translator

10124

AC TEST CIRCUIT

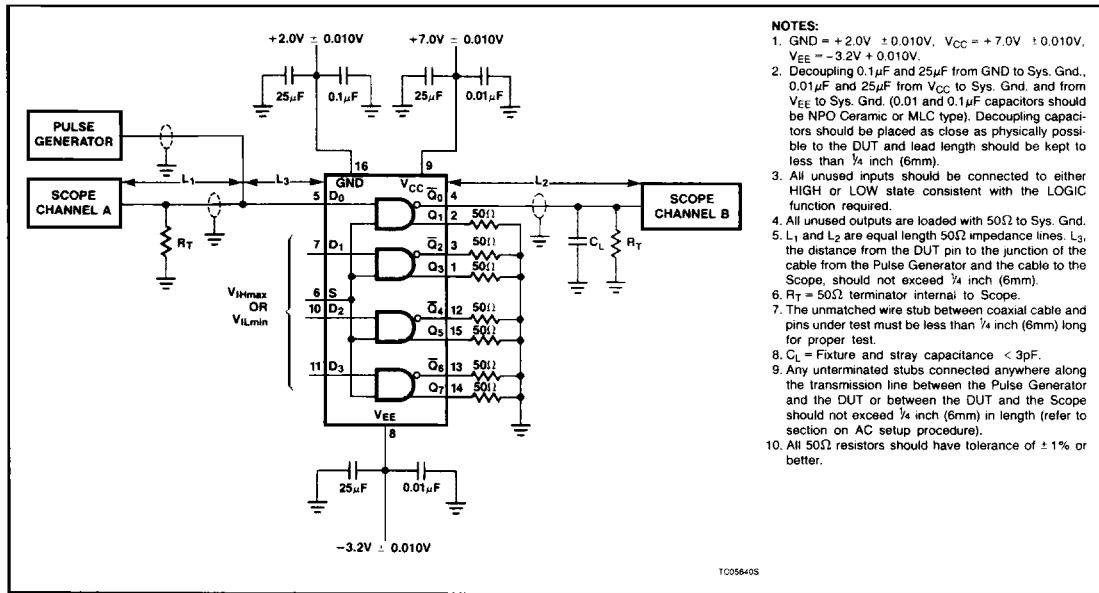

INPUT PULSE DEFINITION

