

CERAMIC SMD TYPE

18 kHz to 20 kHz (SCO-22)

- 18.000 kHz to 20.000 kHz in 0.1 kHz steps
- High Stability with AT-Cut crystal
- External Dimensions : 2.5 × 2.0mm
- 1.8 V to 3.3 V Operating Supply Voltage Range
- CMOS Output
- Tri-state Function Available

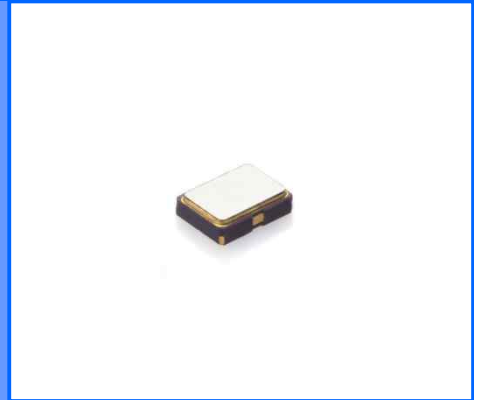

■ ELECTRICAL SPECIFICATIONS

ITEM	Value	Remarks
Output Logic Type	CMOS	CMOS XO
Frequency Range*	18.000 kHz to 20.000 kHz	
Supply Voltage(V _{DD})	1.8 V _{DC} ±5 %, 2.5 V _{DC} ±5 %, 3.3 V _{DC} ±5 %	
Operating Temperature Range	0 to +70 °C, -20 to +70 °C, -40 to +85 °C	
Storage Temperature Range	-55 to +125 °C	
Frequency Stability	±20 ppm, ±25 ppm, ±50 ppm, ±100 ppm Max.	Over operating temperature range
Input Current	5 mA Max.	
Output Voltage Logic High(V _{OH})	90 % of V _{DD} Min.	
Output Voltage Logic Low(V _{OL})	10 % of V _{DD} Max.	
Rise / Fall Time	100 ns Max.	Measured over 10 % to 90 % of waveform
Duty Cycle	45 to 55 %, 40 to 60 %	Measured at 50 % of waveform
Start-up Time	10 ms Max.	
Output Load Condition(CMOS)	15 pF Max.	
Output Enable Function (V _{IH} and V _{IL})	70 % of V _{DD} Min. to Enable Output 30 % of V _{DD} Max. to Disable Output	High Impedance
Frequency Aging	±5 ppm Max.	25°C, First year

* Please contact us about developed standard frequencies

■ MECHANICAL DIMENSIONS (mm)

■ LAND PATTERN (mm)

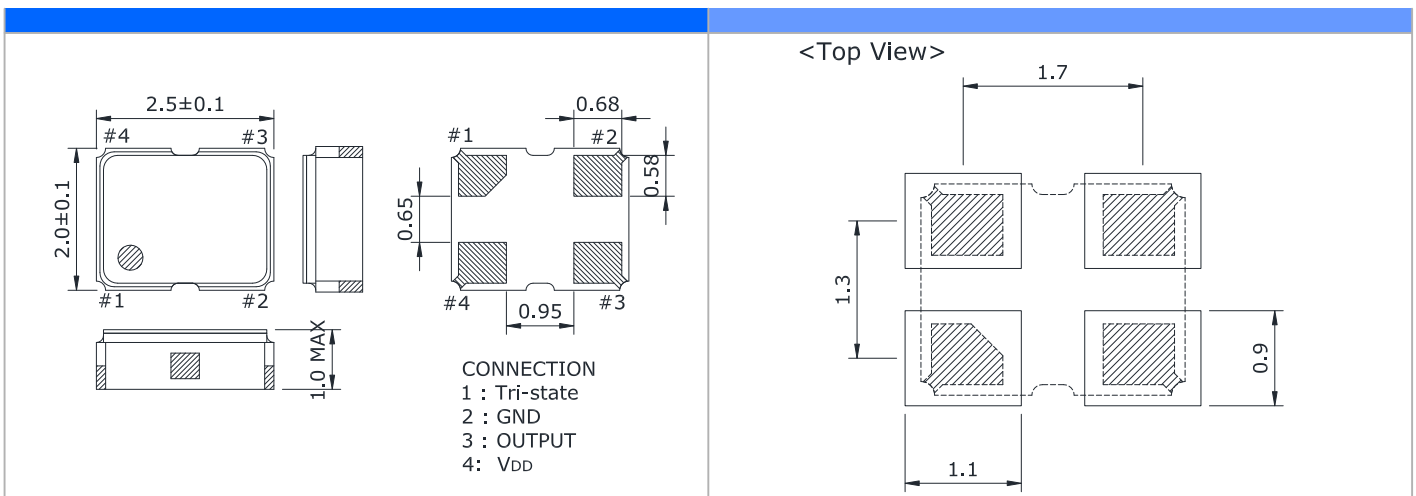

■ PART NUMBERING GUIDE

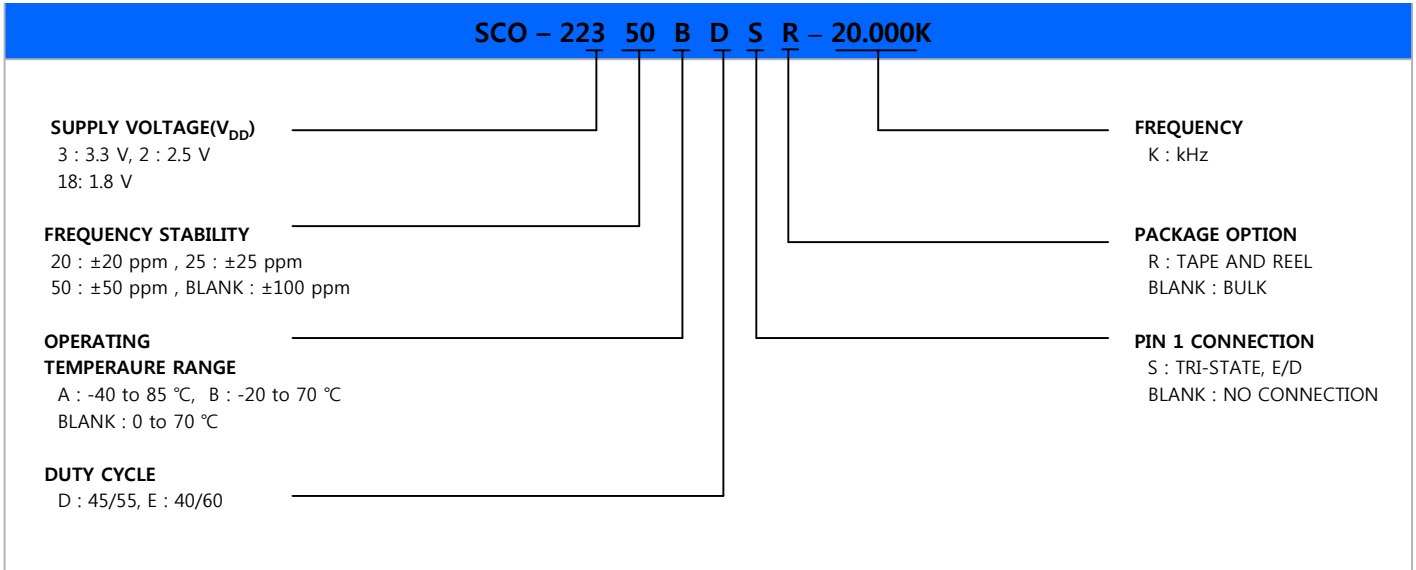

■ TEST CIRCUIT (CMOS)

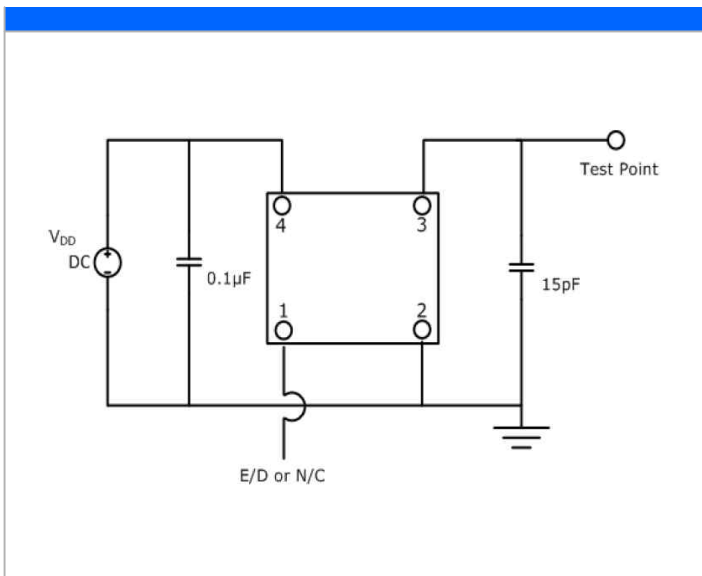

■ WAVEFORM (CMOS)

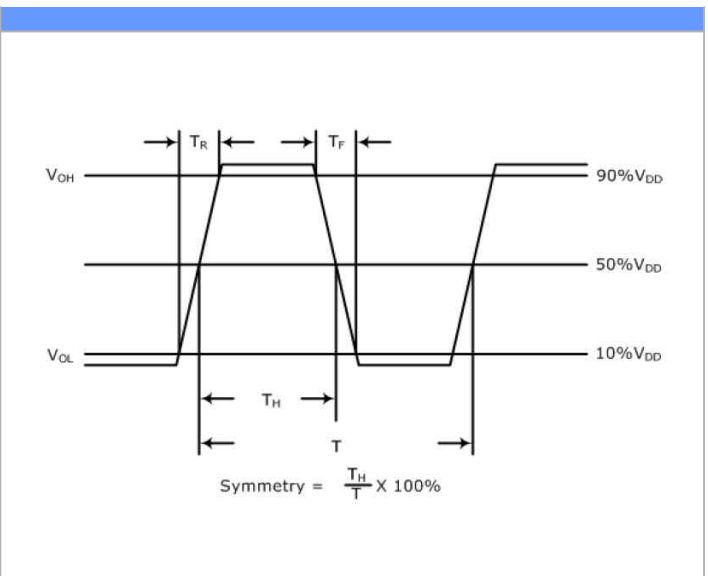

■ ENVIRONMENTAL & MECHANICAL SPECIFICATIONS

Temperature Cycling	MIL-STD-883, Method 1010, Condition B
Fine Leak Test	MIL-STD-883, Method 1014, Condition A
Gross Leak Test	MIL-STD-883, Method 1014, Condition C
Mechanical Shock	MIL-STD-883, Method 2002, Condition B
Vibration	MIL-STD-883, Method 2007, Condition A
Moisture Resistance	MIL-STD-883, Method 1004
Moisture Sensitivity	J-STD-020, MSL 1
Resistance to Soldering Heat	MIL-STD-202, Method 210, Condition K
Solderability	MIL-STD-883, Method 2003

REFLOW PROFILE

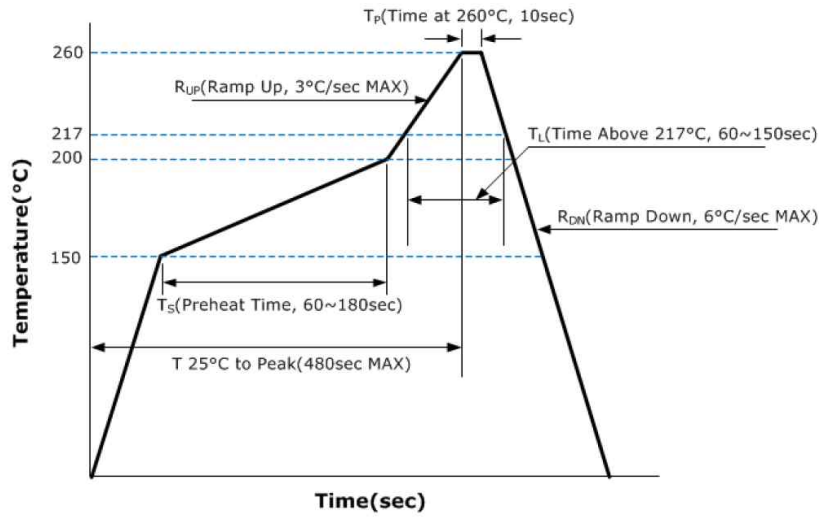

MARKING GUIDE

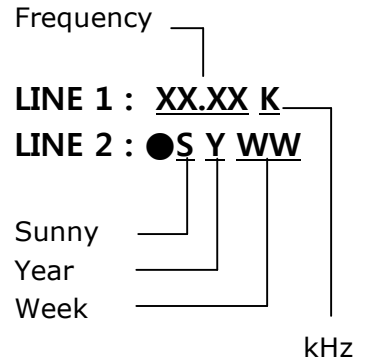

TAPE AND REEL DIMENSIONS

MAT'L : P.S
 COLOR : BLACK
 REFERENCE R=0.2

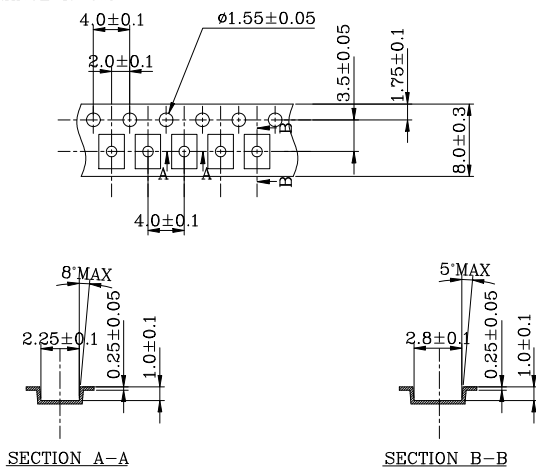

MAT'L : P.S
 COLOR : BLACK

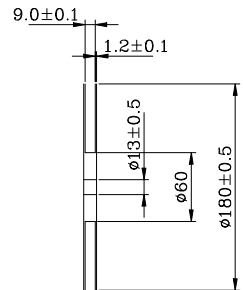
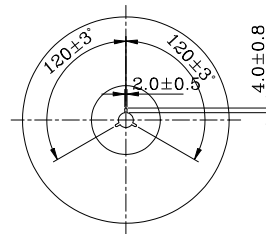

NOTE

- 1. COVER TAPE : 5.4mm(WIDTH)X0.06mm(t) MAT'L : PET
- 2. COLOR : WHITE