



- Robust construction allows for toughest reflow processing
- Complies with or exceeds IEEE 802.3, 10Base-T Standards
- Manufactured in compliance with UL1950/UL1459
- Add “-RC” after part number for RoHS Compliant
- 1500 Vrms Isolation

Electrical Parameters @ 25° C

OCL (μ H Min.)	Insertion Loss (dB Max.)	Return Loss (dB Min.)	Attenuation (dB Min.)				Common Mode Rejection (dB Min.)		Crosstalk (dB Min.)
			@ 20 MHz	@ 25 MHz	@ 30 MHz	@ 40 MHz	10-30 MHz	30-100 MHz	
@ 100 KHz, 20 mVrms	1-10 MHz	5-10 MHz	@ 20 MHz	@ 25 MHz	@ 30 MHz	@ 40 MHz	10-30 MHz	30-100 MHz	1-10 MHz
Cable Side	Xmit	Xmit	Xmit	Xmit	Xmit	Xmit	Xmit/Rcv	Xmit/Rcv	Between Channels
160	-1	-15	-5	-14	-24	-30	-40	-30	-30

• Cut-off Frequency : 17 MHz \pm 1, Ref. @ 5 MHz • Cable Side Impedance : 100 •

Package

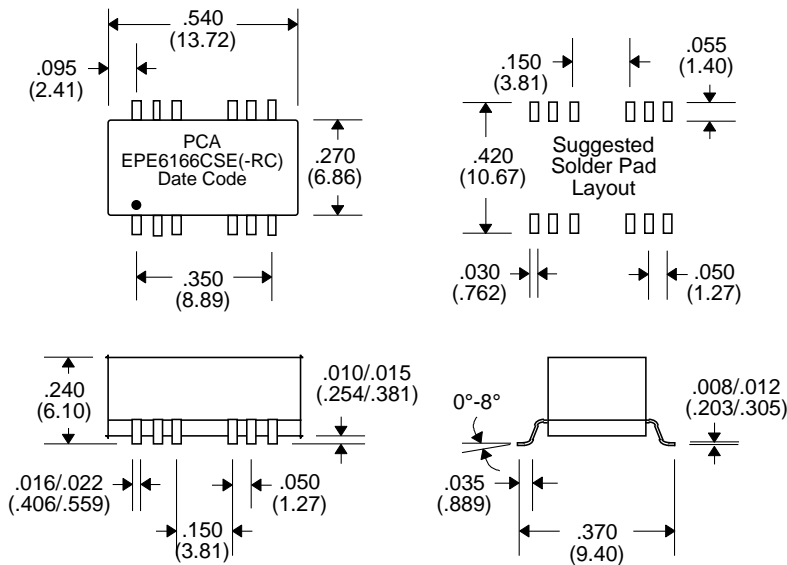

Schematic

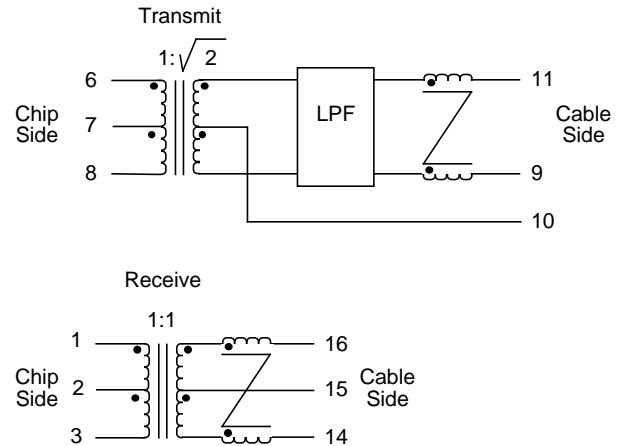

Notes :	EPE6166CSE	EPE6166CSE-RC
1. Lead Finish	SnPb	Hot Tin Dip (Sn) †
2. Peak Temperature Rating	225°C	245°C
3. Moisture Sensitive Levels	MSL = 3 (168 Hours, 30°C/60%RH)	MSL = 4 (72 Hours, 30°C/60%RH)
4. Weight	1.13 grams	1.13 grams
5. Packaging Information (Tube)	34 pieces/tube	34 pieces/tube
(*Add "TR" to end of part number, but in front of "-RC" when placing order) (Tape & Reel)	500 pieces/13" reel (*EPE6166CSETR)	500 pieces/13" reel (*EPE6166CSETR-RC)

† Lead Material : Matte Tin with Ni Barrier

Unless Otherwise Specified Dimensions are in Inches /mm \pm .010 / .25