

CX74005

VGA + I/Q Demodulator Rx ASIC for Portable Phone Applications

The CX74005 Application-Specific Integrated Circuit (ASIC) is a Variable Gain Amplifier (VGA) and I/Q demodulator, intended for use in Code Division Multiple Access (CDMA) portable phones in both cellular and Personal Communications System (PCS) bands. As a trimode IC, it can be used in CDMA mode or Advanced Mobile Phone System (AMPS) mode.

The device incorporates a VGA and the In-Phase and Quadrature (I/Q) demodulator stages. The intermediate frequencies (IF) are combined through separate buffers at the input of the VGA depending on the selected mode. The VGA has a gain control range greater than 90 dB.

There are two Very High Frequency (VHF) oscillators that operate with external tank circuits. They provide signals to the Local Oscillator (LO) for the I/Q demodulator in the cellular and PCS bands.

The noise figure, gain, and third order Input Intercept Point (IIP3) of the CX74005 are optimized to meet the system requirements for AMPS and CDMA modes as per TIA/EIA-98-B and ANSI J-STD-018 (PCS). Employing silicon bipolar technology, the ASIC is designed for high performance and a high level of integration.

The device package and pinout are shown in Figure 1. A block diagram of the CX74005 is shown in Figure 2.

Features

- Supports CDMA/AMPS/PCS1900 modes
- Three battery cell operation (2.7 V < VCC < 3.3 V).
- IF inputs and I/Q outputs
- On-chip 100 to 640 MHz oscillators
- Low power operation: <25 mA
- 32-pin LGA 5X5 mm package

Applications

- Tri-mode handsets
- CDMA and AMPS modes in the cellular band:
 - AMPS
 - CDMA-US
 - CDMA-Japan
- CDMA mode in the PCS band:
 - PCS-US
 - PCS-Korea

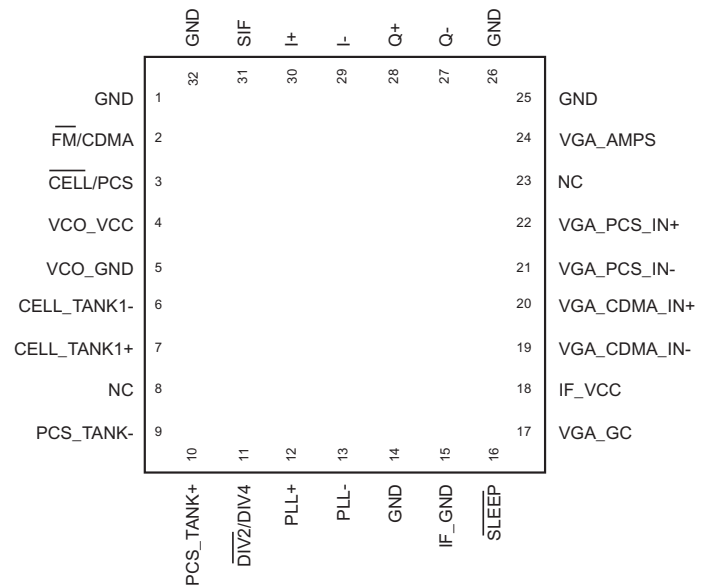

CNXT044

Figure 1. Rx ASIC Pinout – 32-Pin LGA Package (Top View)

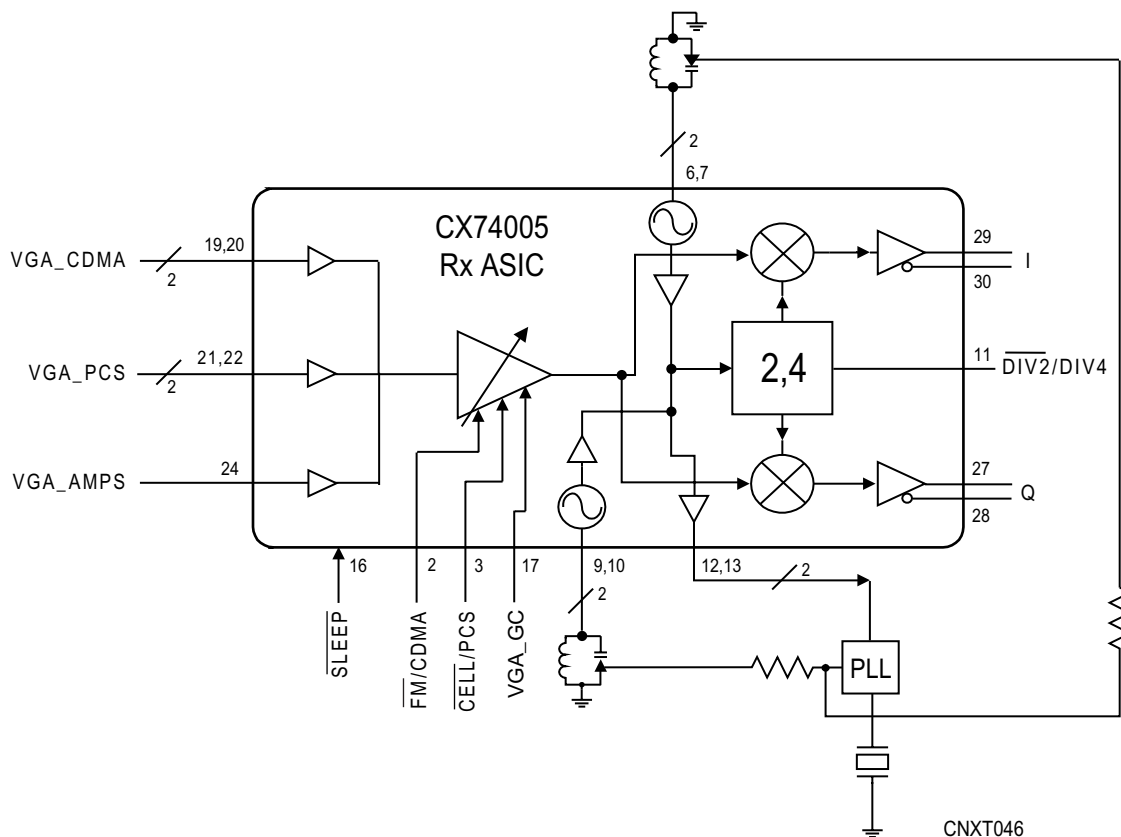

Figure 2. CX74005 Rx ASIC Block Diagram

Technical Description

Variable Gain Amplifier (VGA). The high dynamic range required by CDMA handsets is achieved by the VGA, which is common to all modes. The VGA has a minimum dynamic range of 90 dB with a control voltage of 0.5 to 2.5 volts. The appropriate signal path is switched internal to the device. This eliminates off-chip switching needed to operate this common VGA in cellular AMPS, CDMA, and PCS modes.

I/Q Demodulator. The local oscillator signals are generated on-chip. The I/Q demodulator is internally connected to the VGA output. It is designed to have a very low amplitude and phase imbalance. The I and Q outputs are differential. The DC offsets between the differential outputs and between I and Q channels are designed to be extremely low to facilitate compatibility with baseband interfaces.

VHF Oscillators. There are two on-chip oscillators, one for the cellular and one for the PCS bands. These Voltage Controlled Oscillators (VCOs) work with external tank circuits and varactor diodes. The outputs of the differential oscillators are buffered and the output is used to drive the prescaler of an external Phase Locked Loop (PLL). The VCOs typically operate at twice the IF frequency and can operate at up to four times the IF frequency.

The local oscillators for the I/Q demodulators are derived by an on-chip frequency divider. The logic signal to select the divider ratio (2 or 4) is available on Pin 11 (DIV2/DIV4).

Mode Control. The operation of the chip is controlled by signals at Pin 3 (CELL/PCS), Pin 2 (FM/CDMA), Pin 16 (SLEEP), and the DIV2/DIV4 select commands at Pin 11. All the switching is done internally. The supply voltage should be present at all the VCC pins for normal operation. The signals needed to select each mode is shown in Table 1.

Electrical and Mechanical Specifications. Included in this document are Tables 1 through 5 and Figures 1 through 16, which define the electrical and mechanical specifications of the CX74005.

Table 1:	Mode Control Select Signal Switching
Table 2:	Pin Assignments and Functional Pin Descriptions
Table 3:	Absolute Maximum Ratings
Table 4:	Recommended Operating Conditions
Table 5:	Electrical Specifications
Figure 1:	Pinout Configuration
Figure 2:	Functional Block Diagram
Figures 3 - 11:	Typical Functional Performances
Figure 12:	Package Dimensions
Figure 13:	Tape and Reel Dimensions

ESD Sensitivity

The CX74005 is a Class 1 device. The following extreme Electrostatic Discharge (ESD) precautions are required according to the Human Body Model (HBM):

- Protective outer garments.
- Handle device in ESD safeguarded work area.
- Transport device in ESD shielded containers.
- Monitor and test all ESD protection equipment.

The HBM ESD withstand threshold value, with respect to ground, is ± 1.5 kV. The HBM ESD withstand threshold value, with respect to VDD (the positive power supply terminal) is also ± 1.5 kV.

Table 1. Mode Control Select Signal Switching

Pin	AMPS	CDMA	PCS
3 ($\overline{\text{CELL/PCS}}$)	0	0	1
2 ($\overline{\text{FM/CDMA}}$)	0	1	x
16 ($\overline{\text{SLEEP}}$)	1	1	1
Key: 0 = LOW 1 = HIGH x = N/A Note: DIV 2 is used in the evaluation board			

Table 2. CX74005 Pin Assignments and Signal Descriptions

Pin #	Name	Description
1	GND	Ground
2	$\overline{\text{FM/CDMA}}$	Cellular band mode select: 0 = AMPS, 1 = CDMA
3	$\overline{\text{CELL/PCS}}$	Band select: 0 = Cellular; 1 = PCS
4	VCO_VCC	Voltage supply pin to the VCO buffers. A bypass capacitor should be placed close to the device from pin 4 to pin 5. The trace should be short and connected immediately to the ground plane for best performance.
5	VCO_GND	Ground return from the VCO buffers.
6	CELL_TANK1-	Differential tank connection for the cellular band VCO. Care should be taken during the layout of the external tank circuit to prevent parasitic oscillations.
7	CELL_TANK_1+	Differential tank connection for the cellular band VCO. Care should be taken during the layout of the external tank circuit to prevent parasitic oscillations.
8	NC	No connection
9	PCS_TANK-	Differential tank connection for the PCS band VCO. Care should be taken during the layout of the external tank circuit to prevent parasitic oscillations.
10	PCS_TANK+	Differential tank connection for the PCS band VCO. Care should be taken during the layout of the external tank circuit to prevent parasitic oscillations.
11	$\overline{\text{DIV2/DIV4}}$	Selects the divide ratio of the VCO to the LO port of the I/Q demodulator: 0 = divide by 2, 1 = divide by 4.
12	PLL+	Differential buffered VCO output
13	PLL-	Differential buffered VCO output
14	GND	Ground
15	IF_GND	Ground
16	$\overline{\text{SLEEP}}$	Activates sleep mode: 0 = Sleep, 1 = Enable
17	VGA_GC	The VGA gain control signal. A DC control voltage should be applied to this pin to vary the gain of the VGA.
18	IF_VCC	Voltage supply to VGA and I/Q demodulator stages. Supply should be well regulated and bypassed to prevent modulation of the signal by the supply ripple.
19	VGA_CDMA_IN-	CDMA differential VGA input
20	VGA_CDMA_IN+	CDMA differential VGA input
21	VGA_PCS_IN-	PCS differential VGA input.
22	VGA_PCS_IN+	PCS differential VGA input.
23	GND	Ground
24	VGA_AMPS	AMPS VGA input
25	GND	Ground
26	GND	Ground
27	Q-	Q channel differential output
28	Q+	Q channel differential output
29	I-	I channel differential output
30	I+	I channel differential output
31	GND	Ground
32	GND	Ground

Table 3. Absolute Maximum Ratings

Parameter	Minimum	Maximum	Units
Supply voltage (VCC)	-0.3	+5.5	V
Input voltage range	-0.3	VCC	V
Power dissipation		600	mW
Ambient operating temperature	-30	+80	°C
Storage temperature	-40	+125	°C

Table 4. Recommended Operating Conditions

Parameter	Minimum	Typical	Maximum	Units
Supply voltage (VCC)	2.7	3.0	3.3	V
Operating temperature	-30	+25	+80	°C
Impedance of logic inputs		50		K Ω
Logic 0	0.0		0.5	V
Logic 1	VCC - 0.5		VCC	V

Table 5. CX74005 Rx ASIC Electrical Specifications
TA = 25° C, VCC = 3.3 V

Parameter	Test Condition	Min	Typical	Max	Units
Rx VGA - I/Q Demodulator					
Frequency range		50		300	MHz
Input impedance: AMPS input (single ended) CDMA input (differential) PCS input (differential)			1000 1000 1000		Ω Ω Ω
Voltage gain: Maximum (AMPS) Minimum (AMPS) Maximum (CDMA) Minimum (CDMA) Maximum (PCS) Minimum (PCS)	VGA_GC (V) 2.5 0.5 2.5 0.5 2.5 0.5		58.5 -40.5 55 -46 50.5 -50		dB dB dB dB dB dB
Voltage gain slope			45		dB/V
Voltage gain slope linearity (over any 6 dB segment)		-3		+3	dB
VGA + I/Q IIP3: @ Maximum gain (AMPS) @ Maximum gain (CDMA) @ Maximum gain (PCS)	VGA_GC (V) 2.5 2.5 2.5		-55 -50.5 -47		dBm dBm dBm
Input 1 dB compression @ minimum gain			-10		dBm
VGA + I/Q noise figure: @ Maximum gain (AMPS) @ Maximum gain (CDMA) @ Maximum gain (PCS) @ Minimum gain			5.5 5.0 5.5 50		dB dB dB dB
Output level: AMPS CDMA PCS			2.75 2.50 2.50		mVrms mVrms mVrms
Maximum output level		1.4			Vp-p
Gain variation over frequency: AMPS (0.1-12.2 kHz) CDMA (1-630 kHz) PCS (1-630 kHz)			0.1 0.1 0.1	0.3 0.3 0.3	dB dB dB
I+, I-, and Q+, Q- DC offset				6	mVrms
I/Q gain mismatch			0.2	0.3	dB
I/Q phase mismatch			2	4	deg
Output load impedance (differential)		10K			Ω
Output impedance (differential)		500			Ω
Total supply current (includes I/Q mixers, LO buffers, and dividers)			15		mA
Oscillator					
Frequency range		100		640	MHz
Phase noise (fc = 200 MHz, unloaded Q = 20) @ 100 kHz offset			-117		dBc/Hz
Second harmonic distortion (application dependent)			-30	-26	dBc
Output level to PLL (differential)			300		mVp-p
Output impedance to PLL (differential)			300		Ω
Total supply current (including external tank circuits)			10		mA

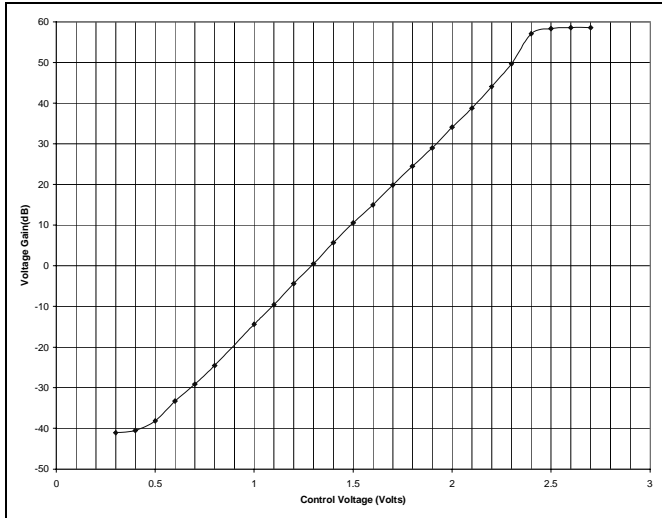

Figure 3. CX74005 Voltage Gain vs. Control Voltage in AMPS Mode

Test Conditions:

RF Input Frequency = 85.38 MHz
 Output Frequency = 1 MHz
 PLL Program Frequency = 172.76 MHz
 Vcc = 3.3 V
 T = 25° C

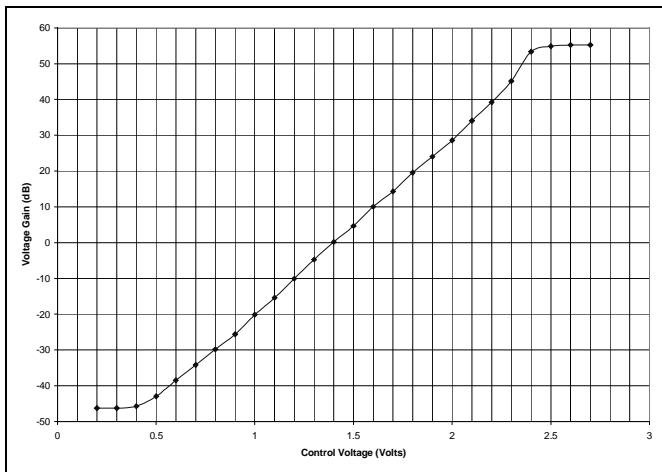

Figure 4. CX74005 Voltage Gain vs. Control Voltage in CDMA Mode

Test Conditions:

RF Input Frequency = 85.38 MHz
 Output Frequency = 1 MHz
 PLL Program Frequency = 172.76 MHz
 Vcc = 3.3 V
 T = 25° C

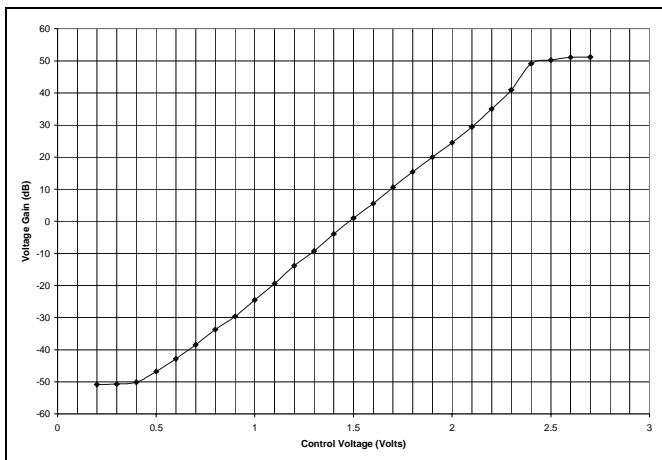

Figure 5. CX74005 Voltage Gain vs. Control Voltage in PCS Mode

Test Conditions:

RF Input Frequency = 210.38 MHz
 Output Frequency = 1 MHz
 PLL Program Frequency = 422.76 MHz
 Vcc = 3.3 V
 T = 25° C

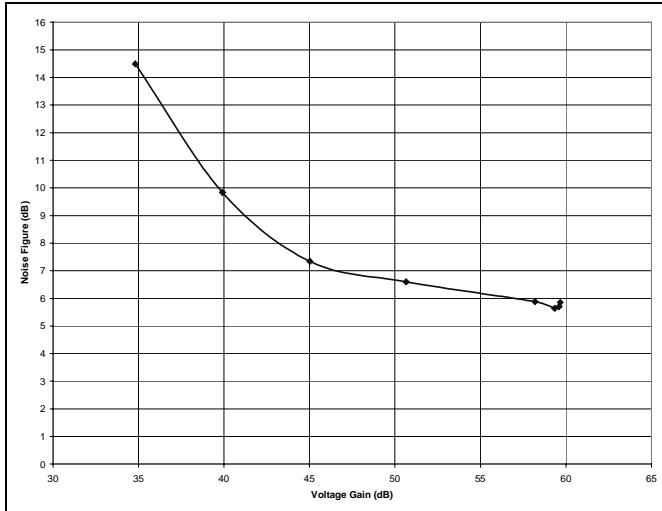

Figure 6. CX74005 Noise Figure vs. Gain in AMPS Mode

Test Conditions:

RF Input Frequency = 85.38 MHz
 Output Frequency = 1 MHz
 PLL Program Frequency = 172.76 MHz
 Vcc = 3.3 V
 T = 25° C

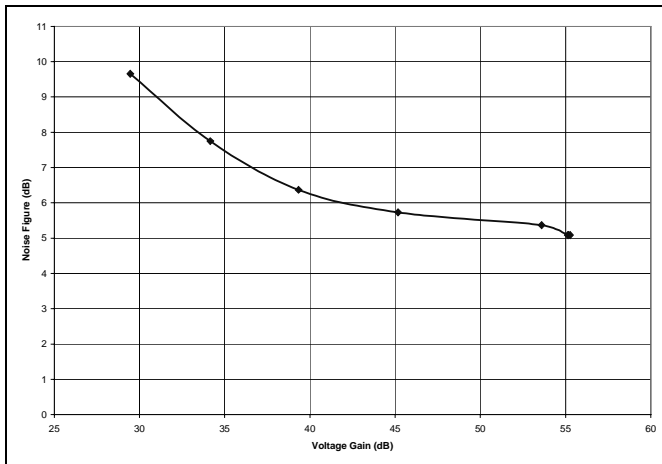

Figure 7. CX74005 Noise Figure vs. Gain in CDMA Mode

Test Conditions:

RF Input Frequency = 85.38 MHz
 Output Frequency = 1 MHz
 PLL Program Frequency = 172.76 MHz
 Vcc = 3.3 V
 T = 25° C

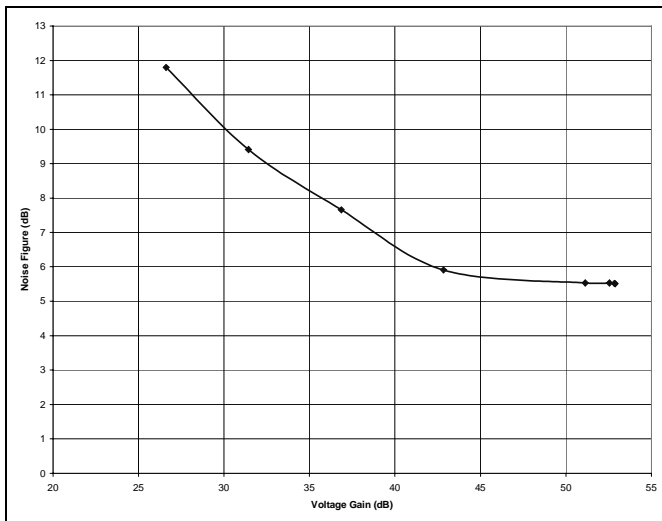

Figure 8. CX74005 Noise Figure vs. Gain in PCS Mode

Test Conditions:

RF Input Frequency = 210.38 MHz
 Output Frequency = 1 MHz
 PLL Program Frequency = 422.76 MHz
 Vcc = 3.3 V
 T = 25° C

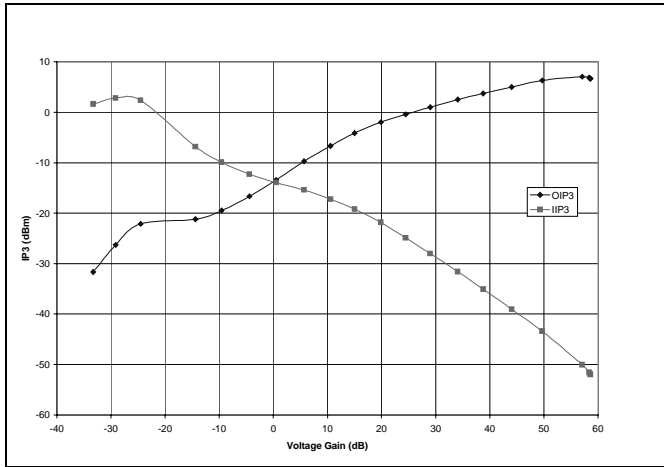

Figure 9. CX74005 IP3 vs. Voltage Gain in AMPS Mode

Test Conditions:

Two Tone Frequencies = 85.28 MHz and 85.48 MHz
 Output IM Frequencies = 0.9 MHz and 1.1 MHz
 PLL Program Frequency = 172.76 MHz
 Vcc = 3.3 V
 T = 25° C

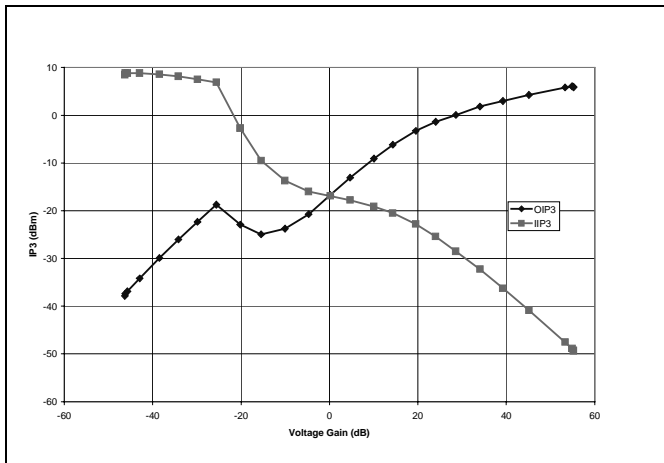

Figure 10. CX74005 IP3 vs. Voltage Gain in CDMA Mode

Test Conditions:

Two Tone Frequencies = 85.28 MHz and 85.48 MHz
 Output IM Frequencies = 0.9 MHz and 1.1 MHz
 PLL Program Frequency = 172.76 MHz
 Vcc = 3.3 V
 T = 25° C

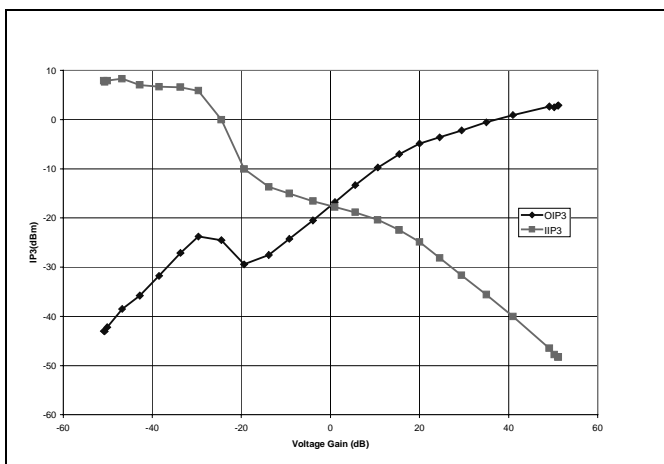

Figure 11. CX74005 IP3 vs. Voltage Gain in PCS Mode

Test Conditions:

Two Tone Frequencies = 210.28 MHz and 210.48 MHz
 Output IM Frequencies = 0.9 MHz and 1.1 MHz
 PLL Program Frequency = 422.38 MHz
 Vcc = 3.3 V
 T = 25° C

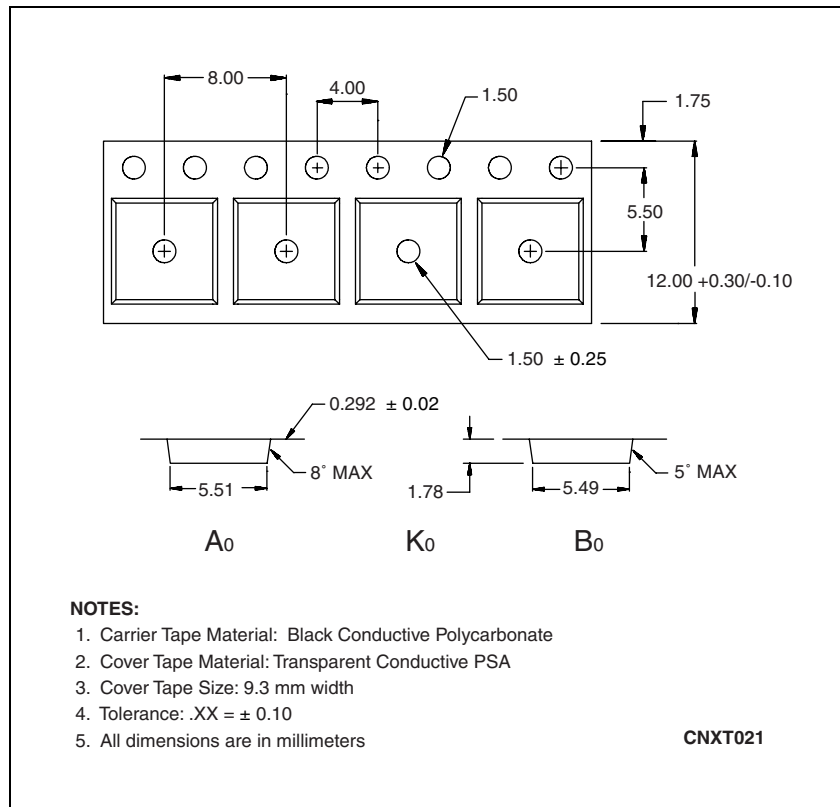

Figure 13. 32-Pin LGA Tape and Reel Dimensions

Ordering Information

Model Name	Manufacturing Part Number	Product Revision
Rx ASIC	CX74005	

© 2000, Conexant Systems, Inc. All Rights Reserved.

Information in this document is provided in connection with Conexant Systems, Inc. ("Conexant") products. These materials are provided by Conexant as a service to its customers and may be used for informational purposes only. Conexant assumes no responsibility for errors or omissions in these materials. Conexant may make changes to specifications and product descriptions at any time, without notice. Conexant makes no commitment to update the information and shall have no responsibility whatsoever for conflicts or incompatibilities arising from future changes to its specifications and product descriptions.

No license, express or implied, by estoppel or otherwise, to any intellectual property rights is granted by this document. Except as provided in Conexant's Terms and Conditions of Sale for such products, Conexant assumes no liability whatsoever.

THESE MATERIALS ARE PROVIDED "AS IS" WITHOUT WARRANTY OF ANY KIND, EITHER EXPRESS OR IMPLIED, RELATING TO SALE AND/OR USE OF CONEXANT PRODUCTS INCLUDING LIABILITY OR WARRANTIES RELATING TO FITNESS FOR A PARTICULAR PURPOSE, CONSEQUENTIAL OR INCIDENTAL DAMAGES, MERCHANTABILITY, OR INFRINGEMENT OF ANY PATENT, COPYRIGHT OR OTHER INTELLECTUAL PROPERTY RIGHT. CONEXANT FURTHER DOES NOT WARRANT THE ACCURACY OR COMPLETENESS OF THE INFORMATION, TEXT, GRAPHICS OR OTHER ITEMS CONTAINED WITHIN THESE MATERIALS. CONEXANT SHALL NOT BE LIABLE FOR ANY SPECIAL, INDIRECT, INCIDENTAL, OR CONSEQUENTIAL DAMAGES, INCLUDING WITHOUT LIMITATION, LOST REVENUES OR LOST PROFITS, WHICH MAY RESULT FROM THE USE OF THESE MATERIALS.

Conexant products are not intended for use in medical, lifesaving or life sustaining applications. Conexant customers using or selling Conexant products for use in such applications do so at their own risk and agree to fully indemnify Conexant for any damages resulting from such improper use or sale.

The following are trademarks of Conexant Systems, Inc.: Conexant™, the Conexant C symbol, and "What's Next in Communications Technologies"™. Product names or services listed in this publication are for identification purposes only, and may be trademarks of third parties. Third-party brands and names are the property of their respective owners.

Additional information, posted at www.conexant.com, is incorporated by reference.

Reader Response: Conexant strives to produce quality documentation and welcomes your feedback. Please send comments and suggestions to tech.pubs@conexant.com. For technical questions, contact your local Conexant sales office or field applications engineer.

**Further Information**

literature@conexant.com
(800) 854-8099 (North America)
(949) 483-6996 (International)
Printed in USA

World Headquarters

Conexant Systems, Inc.
4311 Jamboree Road
Newport Beach, CA
92660-3007
Phone: (949) 483-4600
Fax 1: (949) 483-4078
Fax 2: (949) 483-4391

Americas**U.S. Northwest/**

Pacific Northwest – Santa Clara
Phone: (408) 249-9696
Fax: (408) 249-7113

U.S. Southwest – Los Angeles

Phone: (805) 376-0559
Fax: (805) 376-8180

U.S. Southwest – Orange County

Phone: (949) 483-9119
Fax: (949) 483-9090

U.S. Southwest – San Diego

Phone: (858) 713-3374
Fax: (858) 713-4001

U.S. North Central – Illinois

Phone: (630) 773-3454
Fax: (630) 773-3907

U.S. South Central – Texas

Phone: (972) 733-0723
Fax: (972) 407-0639

U.S. Northeast – Massachusetts

Phone: (978) 367-3200
Fax: (978) 256-6868

U.S. Southeast – North Carolina

Phone: (919) 858-9110
Fax: (919) 858-8669

**U.S. Southeast – Florida/
South America**

Phone: (727) 799-8406
Fax: (727) 799-8306

U.S. Mid-Atlantic – Pennsylvania

Phone: (215) 244-6784
Fax: (215) 244-9292

Canada – Ontario

Phone: (613) 271-2358
Fax: (613) 271-2359

Europe**Europe Central – Germany**

Phone: +49 89 829-1320
Fax: +49 89 834-2734

Europe North – England

Phone: +44 (0)118 920 9500
Fax: +44 (0)118 920 9595

Europe – Israel/Greece

Phone: +972 9 9524000
Fax: +972 9 9573732

Europe South – France

Phone: +33 1 41 44 36 51
Fax: +33 1 41 44 36 90

Europe Mediterranean – Italy

Phone: +39 02 93179911
Fax: +39 02 93179913

Europe – Sweden

Phone: +46 (0) 8 5091 4319
Fax: +46 (0) 8 590 041 10

Europe – Finland

Phone: +358 (0) 9 85 666 435
Fax: +358 (0) 9 85 666 220

Asia – Pacific**Taiwan**

Phone: (886-2) 2-720-0282
Fax: (886-2) 2-757-6760

Australia

Phone: (61-2) 9869 4088
Fax: (61-2) 9869 4077

China – Central

Phone: 86-21-6361-2515
Fax: 86-21-6361-2516

China – South

Phone: (852) 2 827-0181
Fax: (852) 2 827-6488

China – South (Satellite)

Phone: (86) 755-518-2495

China – North

Phone: (86-10) 8529-9777
Fax: (86-10) 8529-9778

India

Phone: (91-11) 692-4789
Fax: (91-11) 692-4712

Korea

Phone: (82-2) 565-2880
Fax: (82-2) 565-1440

Korea (Satellite)

Phone: (82-53) 745-2880
Fax: (82-53) 745-1440

Singapore

Phone: (65) 737 7355
Fax: (65) 737 9077

Japan

Phone: (81-3) 5371 1520
Fax: (81-3) 5371 1501