

## High Voltage Isolated MOSFET Driver

### Ordering Information

Input to Output Isolation Voltage	Package Option
	8-Pin Narrow Body SOIC
±400V	HT0740LG

### Features

- ±400V input to output isolation
- No external voltage supply required
- Low input logic current, 200µA max
- Floating isolated output
- 5.0V logic compatible

### Applications

- Telecommunications
- Modems
- Solid state relays
- High side switches
- High end audio switches
- Avionics
- ATE

### Absolute Maximum Ratings<sup>1</sup>

Input to Output Isolation Voltage, $V_{ISO}$	±400V
Logic Input Voltage, $V_{IN}$	-0.5 to +7.0V
Operating Temperature	-40°C to +85°C
Storage Temperature	-55°C to +150°C
Soldering Temperature <sup>2</sup>	300°C

Note:

1. All voltages are referenced to ground.
2. Distance of 1.6mm from case for 10 seconds.

### General Description

The Supertex HT07 is a single channel high voltage low input current isolated driver utilizing Supertex's proprietary HVCMOS<sup>®</sup> technology. It is designed to drive discrete MOSFETs configured as high side switches up to 400V. The HT07 generates an independent DC isolated voltage across the pair of outputs when the logic input is at a logic high. The HT07 does not require any external power supplies. The internal supply voltage is supplied from the logic input when it is in the high state.

10

### Pin Configuration

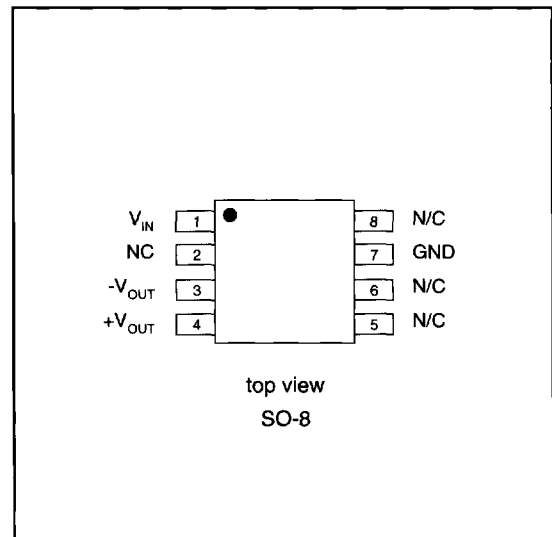

## Electrical Characteristics

(over recommended operating conditions,  $T_A = 25^\circ\text{C}$  unless otherwise specified)

### DC Characteristics

Symbol	Parameter	Min	Typ	Max	Unit	Conditions
$I_H$	Logic input current high			200	$\mu\text{A}$	$V_{IN} = 5.0\text{V}$
$I_{LO}$	Logic input current low (quiescent)			10	$\mu\text{A}$	$V_{IN} = 0.5\text{V}$
$V_{OUT}$	Output voltage across output terminals	5.0			V	$V_{IN} = 3.15\text{V}$ , No load
		9.0			V	$V_{IN} = 4.5\text{V}$ , No load
$V_{IN}$	Input voltage for zero output			0.8	V	No load
$V_{ISO}$	Input to output isolation voltage	$\pm 400$			V	

### AC Characteristics

Symbol	Parameter	Min	Typ	Max	Unit	Conditions
$t_{d(ON)}$	Turn on delay time			50	$\mu\text{s}$	See timing diagram and test circuit $C_L = 600\text{pF}$
$t_r$	Rise time			650	$\mu\text{s}$	
$t_{d(OFF)}$	Turn off delay time			150	$\mu\text{s}$	
$t_f$	Fall time			3.0	ms	

### Recommended Conditions

Symbol	Parameter	Min	Typ	Max	Unit	Conditions
$V_{IH}$	Logic input high voltage	3.15		5.5	V	
$V_{IL}$	Logic input low voltage	0		0.5	V	
$T_A$	Operating temperature	-40		+85	$^\circ\text{C}$	

### Block Diagram

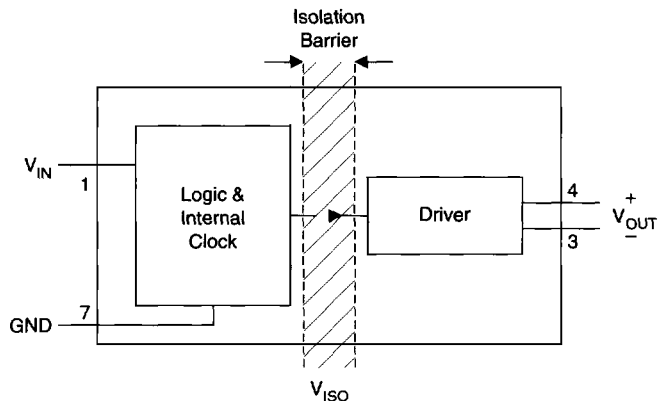

## Timing Diagram

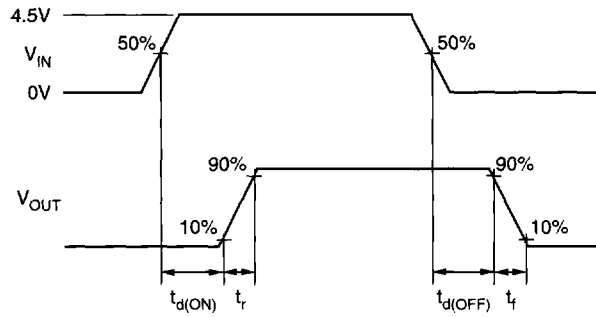

## Test Circuit

