

M2T-25-4-X Optical Gigabit Ethernet Dual Small Form Factor (SFF) Transmitters - 1.25GBaud



Features

- 1.25 Gbps Gigabit Ethernet Performance
- Transmitter Disable Inputs
- Low profile fits Mezzanine Card Applications
- Single +5V Power Supply
- Wave Solderable / Aqueous Washable
- Class 1 Laser Safety Compliant
- UL 1950 Approved

PRODUCT OVERVIEW

The M2T-25-4-X Dual Small Form Factor (SFF) optical transmitters provide high performance unidirectional data links for communication over optical fiber. The M2T-25-4 module is specifically designed to be used in multimode or single mode Gigabit Ethernet applications. The M2T-25-4 transmitters are provided with the LC receptacle which is compatible with the industry standard LC connector. The Methode SFF transmitters measure 0.532 inches in width. These transmitters provide double port densities by fitting twice the number of transmitters into the same board space as a 1x9 module. This saves on system costs and can reduce overall design time.

This dual optoelectronic transmitter module is a class 1 laser product compliant with FDA Radiation Performance Standards, 21 CFR Subchapter J. This component is also class 1 laser compliant according to International Safety Standard IEC-825-1.

SHORT WAVELENGTH LASER

The use of short wavelength VCSELs (Vertical Cavity Surface-Emitting Laser) and high volume production processes has resulted in a low cost, high performance product available in various data transfer rates up to 2.125 GBaud.

LONG WAVELENGTH LASER

The M2T-25-4-2 is provided with single mode optics. The 1300 nm laser provides highly reliable single mode communications which meets or exceeds the Gigabit Ethernet distance requirements.

ORDERING INFORMATION

M2T - 25 - 4 - X

WAVELENGTH

- 1 - 850 nm (multimode)
- 2 - 1300 nm (single mode) 5 km
- 2M - 1300 nm (single mode) 10 km
- 2L - 1300 nm (single mode) 20 km

COMMUNICATIONS PROTOCOL

- 4 - Gigabit Ethernet, 1.25GBaud
- 6 - Fibre Channel, 1.0625GBaud



Optoelectronic Products

7444 West Wilson Avenue • Chicago, IL 60656
 708/867-9600 • 800/323-6858 • Fax: 708/867-0996
 email:optoinfo@methode.com
 http://www.methode.com

ABSOLUTE MAXIMUM RATINGS

PARAMETER	SYMBOL	MIN	MAX	UNITS	NOTES
Storage Temperature	Tstg	-40	85	°C	
Soldering Temperature			260	°C	10 seconds on leads only
Supply Voltage	Vcc		6.0	V	Vcc - ground
Data AC Voltage	Tx+, Tx-		2.6	Vpp	Differential
Data DC Voltage	Tx+, Tx-	-10	10	Vpk	V (Tx+ or Tx-) - ground

RECOMMENDED OPERATING CONDITIONS

PARAMETER	SYMBOL	MIN	TYP	MAX	UNITS	NOTES
Ambient Operating Temperature	Ta	0		70	°C	
Supply Voltage	Vcc	4.5	5.00	5.5	VDC	
Baud Rate	BRate		1.25		GBaud	±100ppm

M2T-25-4-X Optical Gigabit Ethernet Dual Small Form Factor (SFF) Transmitters - 1.25GBaud



MODULE SPECIFICATIONS - ELECTRICAL

Ta = 25° C, Vcc = 5.0 V

PARAMETER	SYMBOL	MIN	TYP	MAX	UNITS	NOTES
Supply Current	I _{cc}		180	185	mA	Ta = 25°C, Vcc = 5.0 V
	I _{cc}			200	mA	0° C < Ta < 70°C, 4.5 V < Vcc < 5.5 V
TRANSMITTER						
ECL Input (Single Ended)		350	720	1250	mVpp	AC coupled inputs
ECL Input (Differential)		700	1440	2500	mVpp	AC coupled inputs
Input Impedance	Z _{in}		50		ohms	R _{in} > 100 kohms @ DC

PERFORMANCE SPECIFICATIONS - OPTICAL 850 nm Laser Multimode

Ta = 25° C, Vcc = 5.0 V

PARAMETER	SYMBOL	MIN	TYP	MAX	UNITS	NOTES
FIBER LENGTH						
50 μm Core Diameter MMF		500	750		m	BER < 1.0E-12 @ 1.25 GBaud
62.5 μm Core Diameter MMF		275	400		m	BER < 1.0E-12 @ 1.25 GBaud
TRANSMITTER						
Optical Transmit Power	P _{opt}	-10		-4	dBm	average @ 850 nm
Optical Center	λ	830	850	860	nm	
Spectral Width	Δλ			.85	nm	RMS
Extinction Ratio	ER	9	10		dB	P1/P0
Relative Intensity Noise	RIN			-117	dB/Hz	
Total Jitter	TJ		150	227	psec	
Deterministic Jitter	DJ			80	psec	
Output Rise, Fall Time	t _r , t _f			0.26	nsec	20 - 80% values, measured unfiltered
Coupled Power Ratio	CPR	9			dB	

M2T-25-4-2 PERFORMANCE SPECIFICATIONS - OPTICAL 1310nm Laser Single Mode

Ta=25°C, Vcc=5.0V

PARAMETER	SYMBOL	MIN	TYP	MAX	UNITS	NOTES
FIBER LENGTH						
9.0 μm Core Diameter SMF		5	10		km	BER < 1.0E-12 @ 1.25 GBaud
TRANSMITTER						
Optical Center	λ	1270	1310	1355	nm	
RMS Spectral Width	Δλ			4	nm	RMS
Optical Transmit Power	P _{opt}	-11.5		-3	dBm	average @ 1310 nm

M2T-25-4-2M PERFORMANCE SPECIFICATIONS - OPTICAL 1310nm Laser Single Mode

Ta=25°C, Vcc=5.0V

PARAMETER	SYMBOL	MIN	TYP	MAX	UNITS	NOTES
FIBER LENGTH						
9.0 μm Core Diameter SMF		10	20		km	BER < 1.0E-12 @ 1.25 GBaud
TRANSMITTER						
Optical Center	λ	1285	1310	1335	nm	
RMS Spectral Width	Δλ			3	nm	RMS
Optical Transmit Power	P _{opt}	-9.5		-3	dBm	average @ 1310 nm

M2T-25-4-2L PERFORMANCE SPECIFICATIONS - OPTICAL 1310nm Laser Single Mode

Ta=25°C, Vcc=5.0V

PARAMETER	SYMBOL	MIN	TYP	MAX	UNITS	NOTES
FIBER LENGTH						
9.0 μm Core Diameter SMF		20	25		km	BER < 1.0E-12 @ 1.25 GBaud
TRANSMITTER						
Optical Center	λ	1300	1310	1320	nm	
RMS Spectral Width	Δλ			2	nm	RMS
Optical Transmit Power	P _{opt}	-7		-3	dBm	average @ 1310 nm

M2T-25-4-X Optical Gigabit Ethernet Dual Small Form Factor (SFF) Transmitters - 1.25GBaud



TERMINATION CIRCUITS

Inputs to the M2T-25 transmitters are AC coupled and internally terminated through 50 ohms to AC ground. These transmitters can operate with PECL or ECL logic levels. Different termination strategies may be required depending on the particular Serializer chip set used.

The M2T-25 product family is designed with AC coupled data inputs to provide the following advantages:

- Close positioning of Serializer with respect to transmitters; allows for shorter line lengths and at gigabit speeds reduces EMI.
- Minimum number of external components.
- Internal termination reduces the potential for unterminated stubs which would otherwise increase jitter and reduce transmission margin.

Subsequently, this affords the customer the ability to optimally locate the Serializer as close to the M2T-25 as possible and save valuable real estate on PCI cards and other small circuit assemblies. At gigabit rates this can provide a significant advantage resulting in better transmission performance and accordingly better signal integrity.

AC coupling allows the Methode M2T-25 to be applied across a wider range of applications without modification. This benefits users in terms of enhanced RF performance, reduced component count, tighter layout and fewer design problems.

Figure 1 illustrates the recommended transmit data line terminations

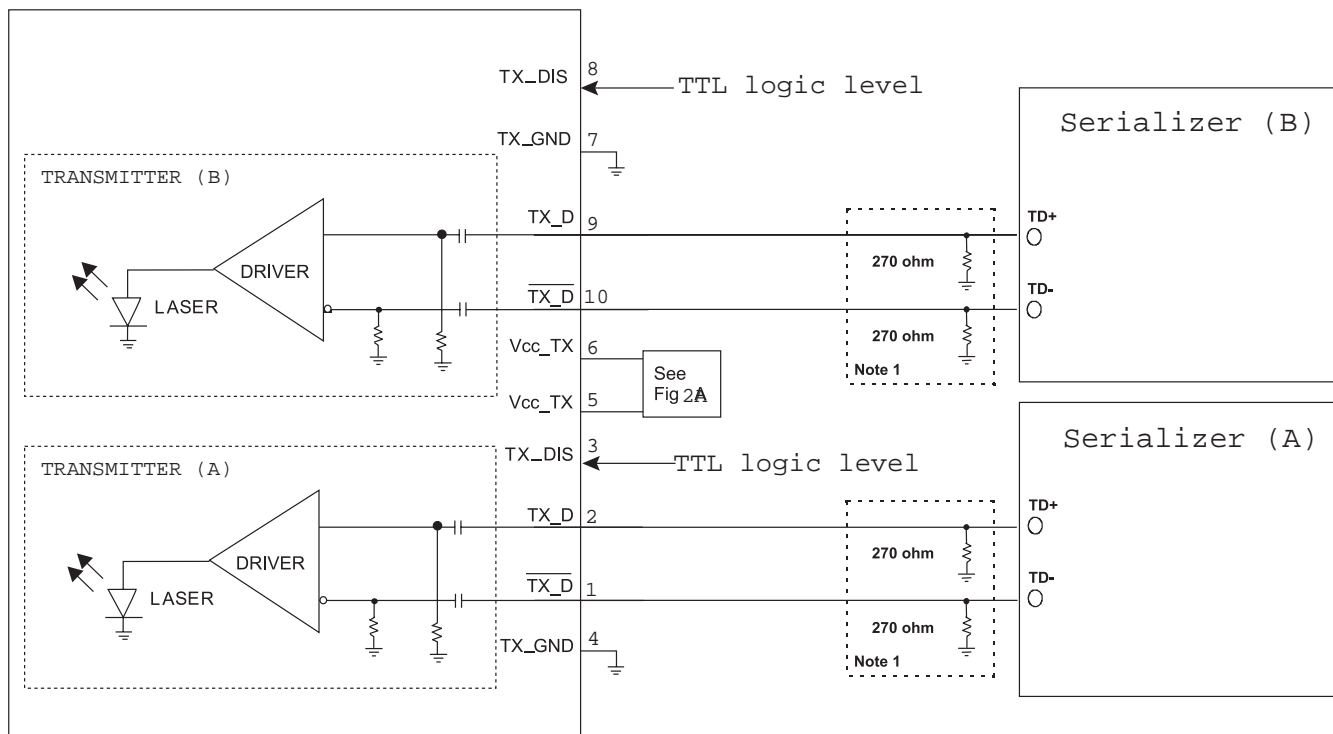

Figure 1. Recommended TRANSMIT Data Terminations

Notes:

1. Consult the SERDES manufacturer's applications information for biasing required for Tx outputs. Some serializer outputs are internally biased and may not need external bias resistors.

M2T-25-4-X Optical Gigabit Ethernet Dual Small Form Factor (SFF) Transmitters - 1.25GBaud



POWER COUPLING

A suggested layout for power and ground connections is given in figure 2B below. Connections are made via separate voltage and ground planes. The mounting posts are at case ground and should not be connected to circuit ground. The ferrite bead should provide a real impedance of 50 to 100 ohms at 100 to 1000 MHz. Bypass capacitors should be placed as close to the 10-pin connector as possible.

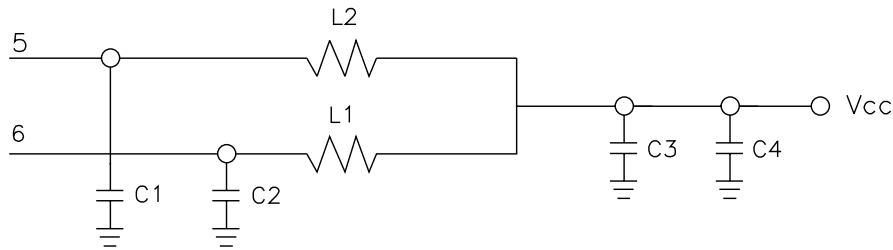

VALUES:

- C1, C2 = 1000pF, COG
- C3, = 0.1uF
- C4, = 10uF, Ta
- L1, L2 = Real impedance of 50 to 100 Ohms to 1000 MHz.

Figure 2A. Suggested Power Coupling - Electrical Schematic

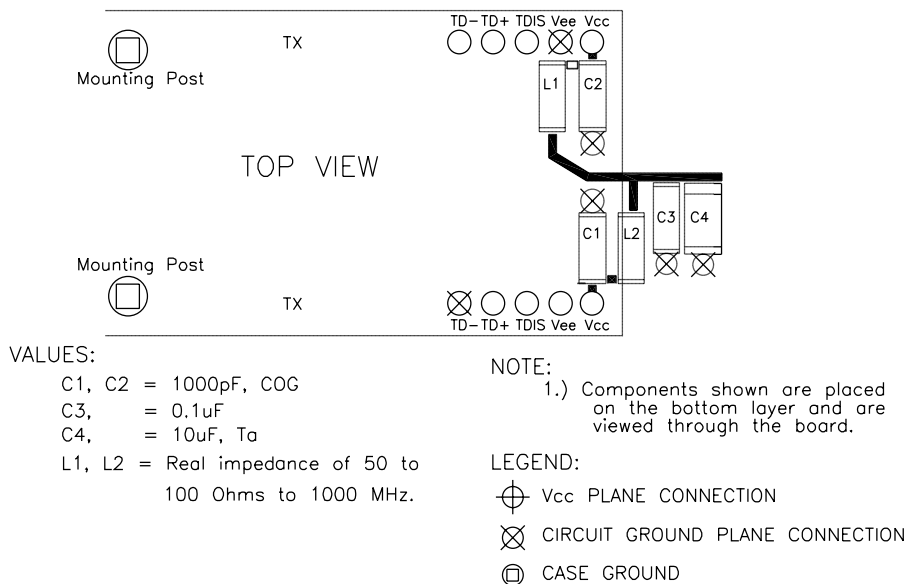

Figure 2B. Suggested Power Coupling - Component Placement

M2T-25-4-X Optical Gigabit Ethernet Dual Small Form Factor (SFF) Transmitters - 1.25GBaud



EMI and ESD CONSIDERATIONS

Method optoelectronic dual transmitters offer a metalized plastic case and a special chassis grounding clip. As shown in the drawing, this clip connects the module case to chassis ground when installed flush through the panel cutout. The grounding clip in this way brushes the edge of the cutout in order to make a proper contact. The use of a grounding clip also provides increased electrostatic protection and helps reduce radiated emissions from the module or the host circuit board through the chassis faceplate. The attaching posts are at case potential and may be connected to chassis ground. They should not be connected to circuit ground.

Plastic optical subassemblies are used to further reduce the possibility of radiated emissions by eliminating the metal from the transmitter which extends into the connector space. By providing a non-metal receptacle for the optical cable ferrule, the gigabit speed RF electrical signal is isolated from the connector area thus preventing radiated energy leakage from these surfaces to the outside of the panel.

MECHANICAL DIMENSIONS –

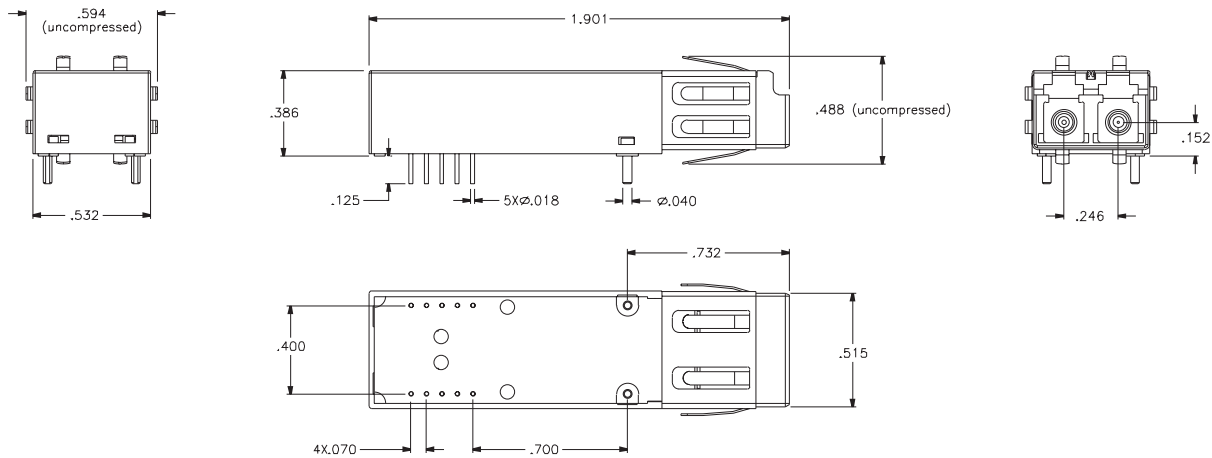

PANEL CUTOUT DIMENSIONS

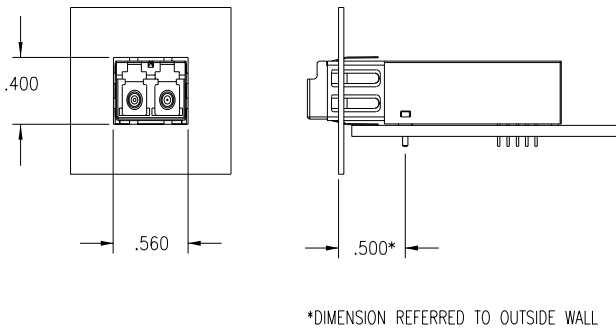

SUGGESTED PCB LAND PATTERN

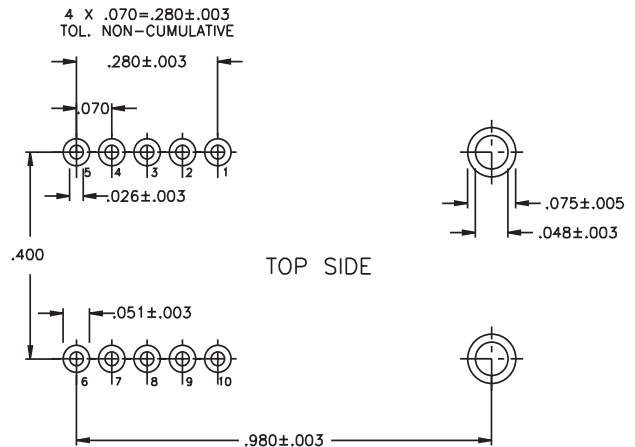

M2T-25-4-X Optical Gigabit Ethernet Dual Small Form Factor (SFF) Transmitters - 1.25GBaud



PHYSICAL DESCRIPTION

The M2T-25 features a compact design with a standard LC duplex connector for fiber optic connections. The 10-pin connector (70 mil spacing) provides the electrical connection for all operation. With a height of 9.8 mm the M2T-25 fits mezzanine card applications. An epoxy encapsulation provides excellent protection from environmental hazards and assists in heat dissipation for all components. Two wave-solderable posts are provided for attaching the package to the circuit board without the need for multiple attachment operations.

ELECTRICAL INTERFACE, PIN DESCRIPTIONS

PIN 1	$\overline{\text{TX_D}}$	Transmitter Data Inverted Differential Input (A)
PIN 2	TX_D	Transmitter Data Non-Inverted Differential Input (A)
PIN 3	TX_DIS	Transmitter Disable (A)
PIN 4	TX_GND	Ground (A)
PIN 5	Vcc-TX	+5 volt supply for the Transmitter Section (A)
PIN 6	Vcc_TX	+5 volt supply for the Transmitter Section (B)
PIN 7	TX_GND	Ground (B)
PIN 8	TX_DIS	Transmitter Disable (B)
PIN 9	TX_D	Transmitter Data Non-Inverted Differential Input (B)
PIN 10	$\overline{\text{TX_D}}$	Transmitter Data Inverted Differential Input (B)
Attaching Posts		The attaching posts are at case potential and may be connected to chassis ground. They should not be connected to circuit ground.



Optoelectronic Products

7444 West Wilson Avenue • Chicago, IL 60656
708/867-9600 • 800/323-6858 • Fax: 708/867-0996
email:optoinfo@methode.com
<http://www.methode.com>

IMPORTANT NOTICE

Methode Electronics reserves the right to make changes to or discontinue any optical link product or service identified in this publication, without notice, in order to improve design and/or performance. Methode advises its customers to obtain the latest version of the publications to verify, before placing orders, that the information being relied on is current. Methode Electronics Small Form Factor (SFF) products are covered under U.S. Patent Numbers 5,812,582 and 5,864,468.

Methode Electronics warrants performance of its optical link products to current specifications in accordance with Methode Electronics standard warranty. Testing and other quality control techniques are utilized to the extent that Methode Electronics has determined it to be necessary to support this warranty. Specific testing of all parameters of each optical link product is not necessarily performed on all optical link products.

Methode Electronic products are not designed for use in life support appliances, devices, or systems where malfunction of a Methode Electronics product can reasonably be expected to result in a personal injury. Methode Electronics customers using or selling optical link products for use in such applications do so at their own risk and agree to fully indemnify Methode Electronics for any damages resulting from such improper use or sale.

Methode Electronic assumes no liability for Methode Electronics applications assistance, customer product design, software performance, or infringement of patents or services described herein. Nor does Methode Electronics warrant or represent that a license, either expressed or implied is granted under any patent right, copyright, or intellectual property right, and makes no representations or warranties that these products are free from patent, copyright, or intellectual property rights.

Applications that are described herein for any of the optical link products are for illustrative purposes only. Methode Electronics makes no representation or warranty that such applications will be suitable for the specified use without further testing or modification.