

Helping Customers Innovate, Improve & Grow



VT-804

Description

Vectron's VT-804 Temperature Compensated Crystal Oscillator (TCXO) is a quartz stabilized, Clipped sine wave or CMOS output, 5th order analog temperature compensated oscillator, operating off a 2.8V to 5.0 volt supply in a hermetically sealed 3.2x5mm ceramic package.

Features

- Clipped Sine Wave or CMOS Output
- 10.000 - 52.000MHz Output Frequency
- ± 50 ppb Temperature Stability
- Optional Frequency Tuning
- Fundamental Crystal Design
- Gold over nickel contact pads
- Hermetically Sealed Ceramic SMD package
- Product is compliant to RoHS directive  and fully compatible with lead free assembly

Applications

- Femto Cells
- Base Stations
- IP Networking
- Global Positioning Systems
- Point to Point Radio
- Manpack Radio
- Test and Measurement

Block Diagram

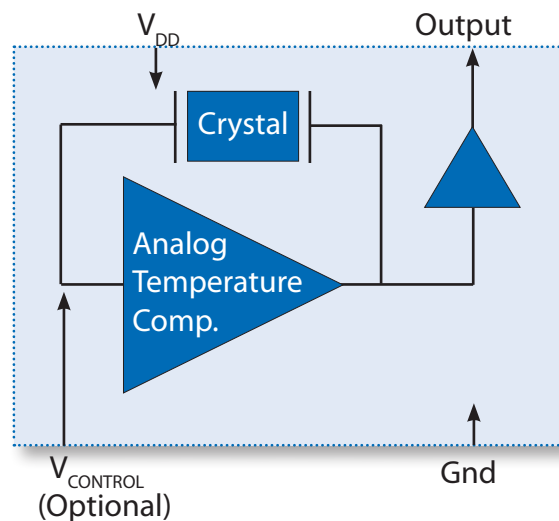

Specifications

Table 1. Electrical Performance, Clipped Sine Wave Option

Parameter	Symbol	Min.	Typ	Max	Units
Output Frequency ¹ , <i>Ordering Option</i>	f_o	10		52	MHz
Supply Voltage ³ , <i>Ordering Option</i>	V_{DD}	+2.8, +3.0, +3.3, +5.0			V
Supply Current 10.000MHz - 26.000MHz 26.001MHz - 52.000MHz	I_{DD}			2.0 3.0	mA
Operating Temperature, <i>Ordering Option</i>	T_{OP}	0/55, -10/70, -20/70, -30/85, -40/85			°C
Frequency Stability					
Stability Over T_{OP} ⁴ , <i>Ordering Option</i>	F_{STAB}	±0.05, ±0.10, ±0.20, ±0.28, ±0.50, ±1.00, ±2.00			ppm
Frequency Tolerance ⁵	F_{TOL}			±1.5	ppm
Power Supply Stability, ±5%	F_{PWR}			±0.1	ppm
Load Stability, ±5%	F_{LOAD}			±0.1	ppm
Aging / 1st year	F_{AGE}			±1.0	ppm
Frequency Tuning (EFC), <i>Ordering Option</i>					
Tuning Range ⁶	PR	±5.0, ±8.0, ±10.0, ±12.0			ppm
Tuning Slope		Positive			
Control Voltage to reach Pull Range	V_C	0.5	1.5	2.5	V
Control Voltage Impedance		100			Kohm
RF Output (Clipped Sine Wave), <i>Ordering Option</i>					
Output Level High	V_o p-p	0.8			V
Output Load	C_L			10k 10pF	
Start Up Time	t_{SU}			2	ms
Phase Noise⁷					
Phase Noise, 30.720MHz ⁷ 10Hz 100Hz 1kHz 10kHz 100kHz	\emptyset_N		-92 -115 -133 -146 -158		dBc/Hz
Integrated Jitter, 30.720MHz ⁷ 12kHz-5MHz			0.20		ps-rms

1. Refer to Table 8 for Standard Frequencies. Other Frequencies are available on request. Check with factory.
2. Output DC-cut capacitor is optional.
3. The VT-804 power supply pin (Pin4) should be filtered using a by-pass capacitor of 0.1uF for optimal performance.
4. Referenced to the midpoint between minimum and maximum frequency value over Operating Temperature Range.
5. Frequency measured at 25 °C, 1 hour after 2 IR reflows.
6. Referenced to Mid Control Voltage
7. Measured at ambient temperature using Agilent E5052B Signal Source Analyzer.

Table 2. Electrical Performance, CMOS Option					
Parameter	Symbol	Min.	Typ	Max	Units
Output Frequency ¹ , <i>Ordering Option</i>	f_o	10		40	MHz
Supply Voltage ³ , <i>Ordering Option</i>	V_{DD}	+2.8, +3.0, +3.3, +5.0			V
Supply Current 10.000MHz - 26.000MHz 26.001MHz - 52.000MHz	I_{DD}			3.5 8.0	mA
Operating Temperature, <i>Ordering Option</i>	T_{OP}	0/55, -10/70, -20/70, -30/85, -40/85			°C
Frequency Stability					
Stability Over T_{OP} ⁴ , <i>Ordering Option</i>	F_{STAB}	±0.05, ±0.10, ±0.20, ±0.28, ±0.50, ±1.00, ±2.00			ppm
Frequency Tolerance ⁵	F_{TOL}			±1.5	ppm
Power Supply Stability, ±5%	F_{PWR}			±0.3	ppm
Load Stability, ±5%	F_{LOAD}			±0.1	ppm
Aging / 1st year	F_{AGE}			±1.0	ppm
Frequency Tuning (EFC), <i>Ordering Option</i>					
Tuning Range ⁶	PR	±5.0, ±8.0, ±10.0, ±12.0			ppm
Tuning Slope		Positive			
Control Voltage to reach Pull Range	V_C	0.5	1.5	2.5	V
Control Voltage Impedance		100			Kohm
RF Output (CMOS), <i>Ordering Option</i>					
Output Level High Output Level Low	V_{OH} V_{OL}	0.9* V_{DD}		0.1* V_{DD}	V
Output Load	C_L			15	pF
Duty Cycle		45		55	%
Start Up Time	t_{SU}			2	ms
Rise & Fall Times				5	ns
Phase Noise ⁷					
Phase Noise, 30.720MHz ⁷ 10Hz 100Hz 1kHz 10kHz 100kHz	\emptyset_N		-90 -112 -134 -150 -156		dBc/Hz
Integrated Jitter, 30.720MHz ⁷ 12kHz - 5MHz			0.22		ps-rms

1. Refer to Table 8 for Standard Frequencies. Other Frequencies are available on request. Check with factory.
2. Output DC-cut capacitor is optional.
3. The VT-804 power supply pin (Pin4) should be filtered using a by-pass capacitor of 0.1uF for optimal performance.
4. Referenced to the midpoint between minimum and maximum frequency value over Operating Temperature Range.
5. Frequency measured at 25 °C, 1 hour after 2 IR reflows.
6. Referenced to Mid Control Voltage.
7. Measured at ambient temperature using Agilent E5052B Signal Source Analyzer

Phase Noise Performance for 30.72MHz Clipped Sine Wave

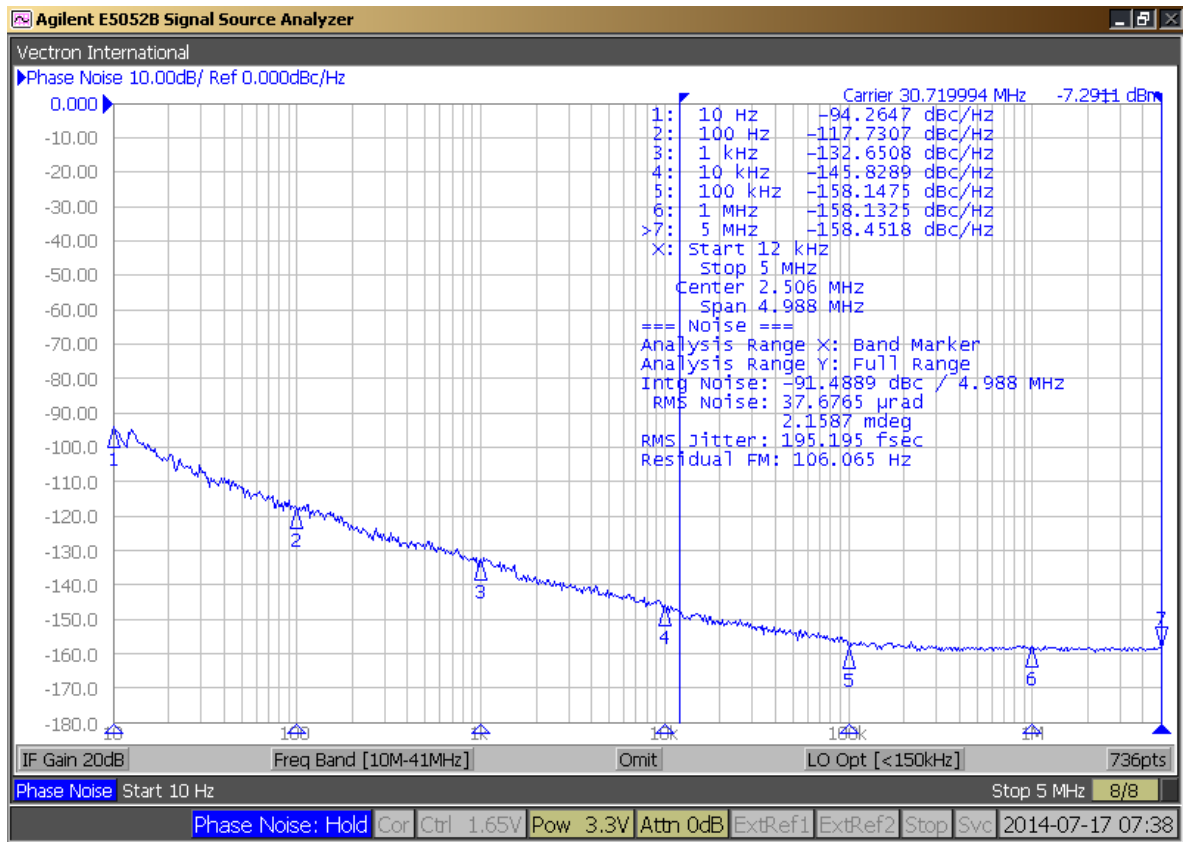

Phase Noise Performance for 30.72MHz CMOS

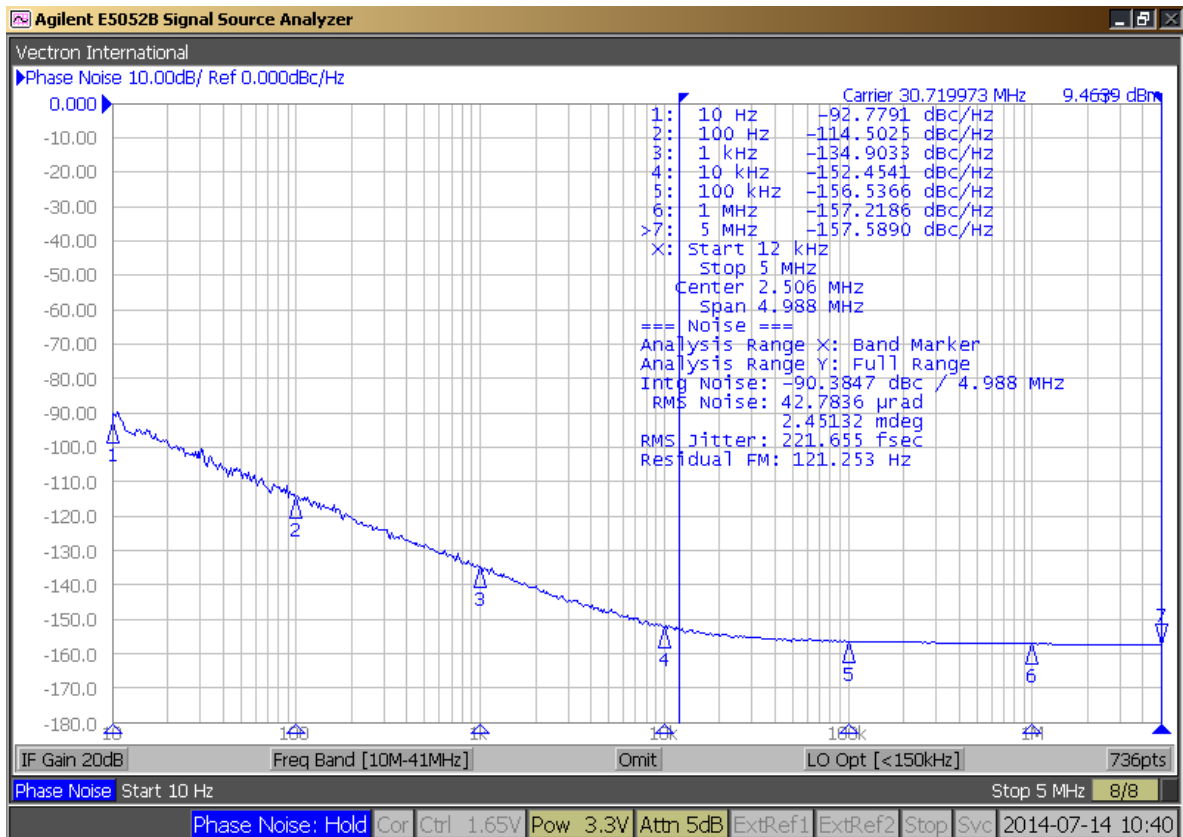

Package Outline Drawing

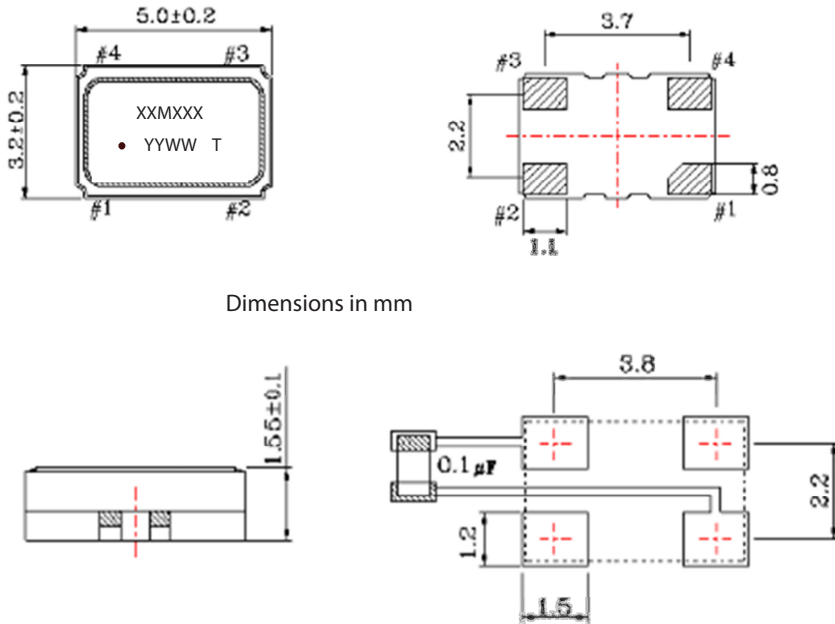

Dimensions in mm

Marking Information

XXMXX - Frequency (Example: 30M720)

YY - Year of Manufacture

WW - Week of the Year

T - Manufacturing Location

• - Pin 1 Indicator

Table 3. Pinout

Pin #	Symbol	Function
1	V _c or NC	TCXO Control Voltage or No Connect
2	GND	Ground
3	OUT	RF Output
4	V _{DD}	Supply Voltage

Note:

0.1μF capacitor is a by-pass power supply filter capacitor placed between Pin4 (V_{DD}) and Ground for optimal performance.

VCXO Function

VCXO Feature: The VT-804 is supplied with a VCXO function for applications where it will be used in a PLL, or the output frequency needs fine tune or calibration adjustments. This is a high impedance input, 100kOhm, and can be driven with an op-amp or terminated with adjustable resistors etc. **Pin1 should not be left floating on the VCXO optional device.**

Maximum Ratings

Absolute Maximum Ratings and Handling Precautions

Stresses in excess of the absolute maximum ratings can permanently damage the device. Functional operation is not implied or any other excess of conditions represented in the operational sections of this data sheet. Exposure to absolute maximum ratings for extended periods may adversely affect device reliability.

Although ESD protection circuitry has been designed into the VT-804, proper precautions should be taken when handling and mounting. VI employs a Human Body Model and Charged Device Model for ESD susceptibility testing and design evaluation.

ESD thresholds are dependent on the circuit parameters used to define the model. Although no industry standard has been adopted for the CDM a standard resistance of 1.5kOhms and capacitance of 100pF is widely used and therefore can be used for comparison purposes.

Table 4. Maximum Ratings

Parameter	Symbol	Rating	Unit
Storage Temperature	T _{STORE}	-55/125	°C
Supply Voltage	V _{DD}	-0.6/6	V
Control Voltage	V _c	-0.6/V _{DD} +0.6	V
Enable/Disable Voltage	E/D	-0.6/V _{DD} +0.6	V
ESD, Human Body Model		1500	V
ESD, Charged Device Model		1000	V

Reliability

Parameter	Condition
Mechanical Shock	MIL-STD-883 Method 2002
Mechanical Vibration	MIL-STD-883 Method 2007
Temperature Cycle	MIL-STD-883 Method 1010
Solderability	MIL-STD-883 Method 2003
Fine and Gross Leak	MIL-STD-883 Method 1014
Resistance to Solvents	MIL-STD-883 Method 2015
Moisture Sensitivity Level	MSL1
Contact Pads	Gold over Nickel

IR Reflow

Suggested IR Profile

Devices are built using lead free epoxy and can be subjected to standard lead free IR reflow conditions shown in Table 6. Contact pads are gold over nickel and lower maximum temperatures can also be used, such as 220°C.

Parameter	Symbol	Value
PreHeat Time Ts-min Ts-max	t_s	200 sec Max 150°C 200°C
Ramp Up	R_{UP}	3°C/sec Max
Time above 217C	t_L	150 sec Max
Time to Peak Temperature	$t_{25C \text{ to peak}}$	480 sec Max
Time at 260C	t_p	30 sec Max
Time at 240C	t_{p2}	60 sec Max
Ramp down	R_{DN}	6°C/sec Max

Solderprofile:

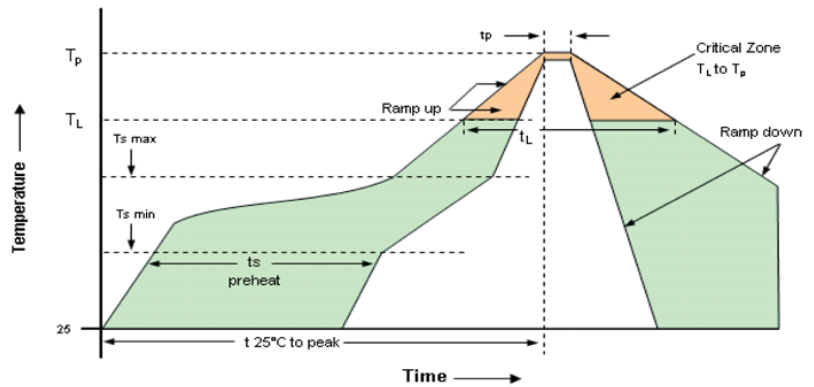

Tape & Reel

Table 7. Tape and Reel Information

Tape Dimensions (mm)						Reel Dimensions (mm)						
W	F	Do	Po	P1	A	B	C	D	N	W1	W2	#/Reel
12	5.5	1.5	4	8	180	2.5	13	21	60	12.5	15.5	2000

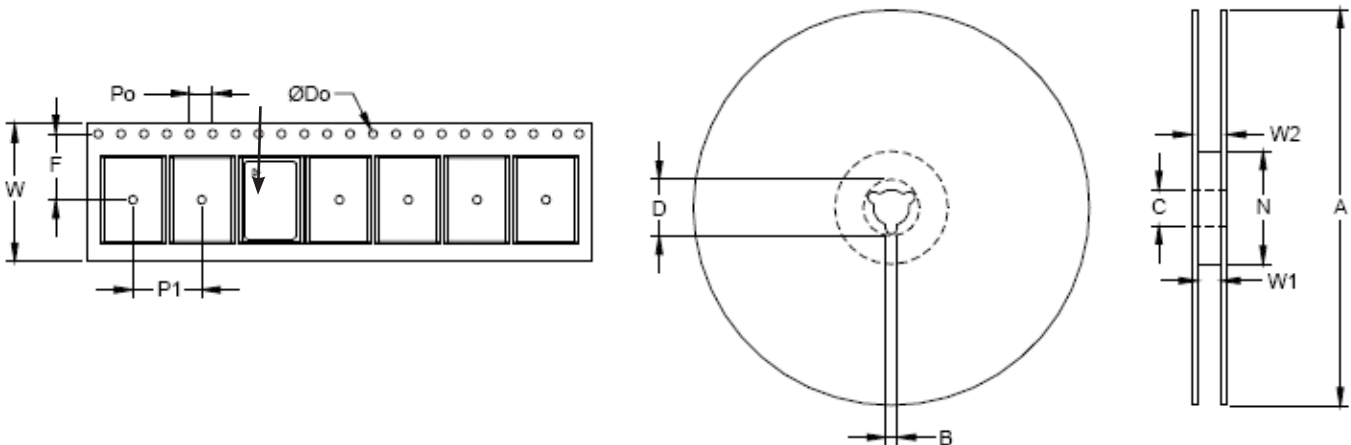

Ordering Information

Table 8. Standard Frequencies (MHz)

10.000	12.800	19.200	20.000	24.000	26.000	28.800	30.720	40.000	50.000

Note: Other Frequencies are available on request.

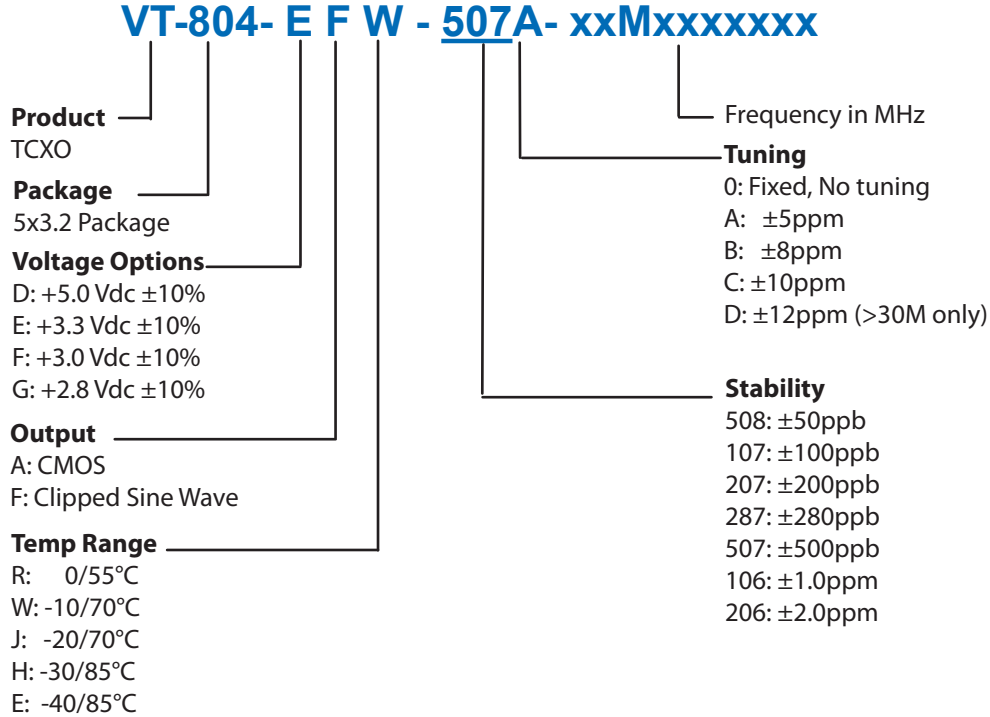

Table 9. Capability Chart [Clipped Sine & CMOS Output]

	50ppb	100ppb	200ppb	280ppb	500ppb	1ppm
0/55°C	●	●	●	●	●	●
-10/70°C	●	●	●	●	●	●
-20/70°C	●	●	●	●	●	●
-30/85°C	●	●	●	●	●	●
-40/85°C	●	●	●	●	●	●

- = Can be provided.
- = Under development. Please consult with factory.
- = Cannot be provided.

For Additional Information, Please Contact

USA:

Vectron International
267 Lowell Road, Suite 102
Hudson, NH 03051
Tel: 1.888.328.7661
Fax: 1.888.329.8328

Europe:

Vectron International
Landstrasse, D-74924
Neckarbischofsheim, Germany
Tel: +49 (0) 3328.4784.17
Fax: +49 (0) 3328.4784.30

Asia:

Vectron International
68, Yin Cheng Road (C), 22nd Floor
One LuJiaZui
Pudong, Shanghai 200120, China
Tel: 86.21.6194.6886
Fax: 86.21.6194.6699

Disclaimer

Vectron International reserves the right to make changes to the product(s) and or information contained herein without notice. No liability is assumed as a result of their use or application. No rights under any patent accompany the sale of any such product(s) or information.

Revision History

Revision Date	Approved	Description
July 17, 2014	VN	Rev 0.1: VT-804 Product Preliminary Datasheet - Internal Verification
August 28, 2014	VN	Rev 0.2: VT-804 Product Release - Wesbite
November 14, 2016	VN	Rev 0.3: Updated Clipped Sine Wave and CMOS current draw for high frequency range.