

**REAL-TIME CLOCK**

**S-3511A**

The S-3511A is CMOS real-time clock that supplies and sets time and calendar data when requested by the CPU. Software processing is reduced by connecting the CPU via 3 wires and due to an interrupt/alarm function. The constant voltage drive of the oscillation circuit also enables low current consumption. The packages are 8-Pin SOP and 8-Pin SSOP.

■ **Features**

- Low current consumption : 0.7  $\mu$ A typ.(V<sub>DD</sub> = 3.0 V, T<sub>a</sub> = 25°C)
- Wide operating voltage range : 1.7 V to 5.5 V
- BCD I/O of second, minute, hour, day, date, month and year
- Interface to CPU with 3 lines
- Built-in automatic calendar, automatic leap-year calculation up to 2099
- Built-in voltage detector
- Built-in constant voltage circuit
- Built-in flag generation circuit during power-on and power down
- Built-in alarm interrupter
- Steady-state interrupt frequency/duty setting function
- Built-in 32 kHz oscillation circuit (Internal C<sub>d</sub>, External C<sub>g</sub> and Crystal)
- Package: Die

8-Pin SSOP (pin pitch: 0.65 mm) Package drawing code :FS008-A  
 8-Pin SOP (pin pitch: 1.27 mm) Package drawing code :FJ008-D

■ **Applications**

- Cellular phone
- PHS
- A variety of pagers
- TV set and VCR
- Camera

■ **Block Diagram**

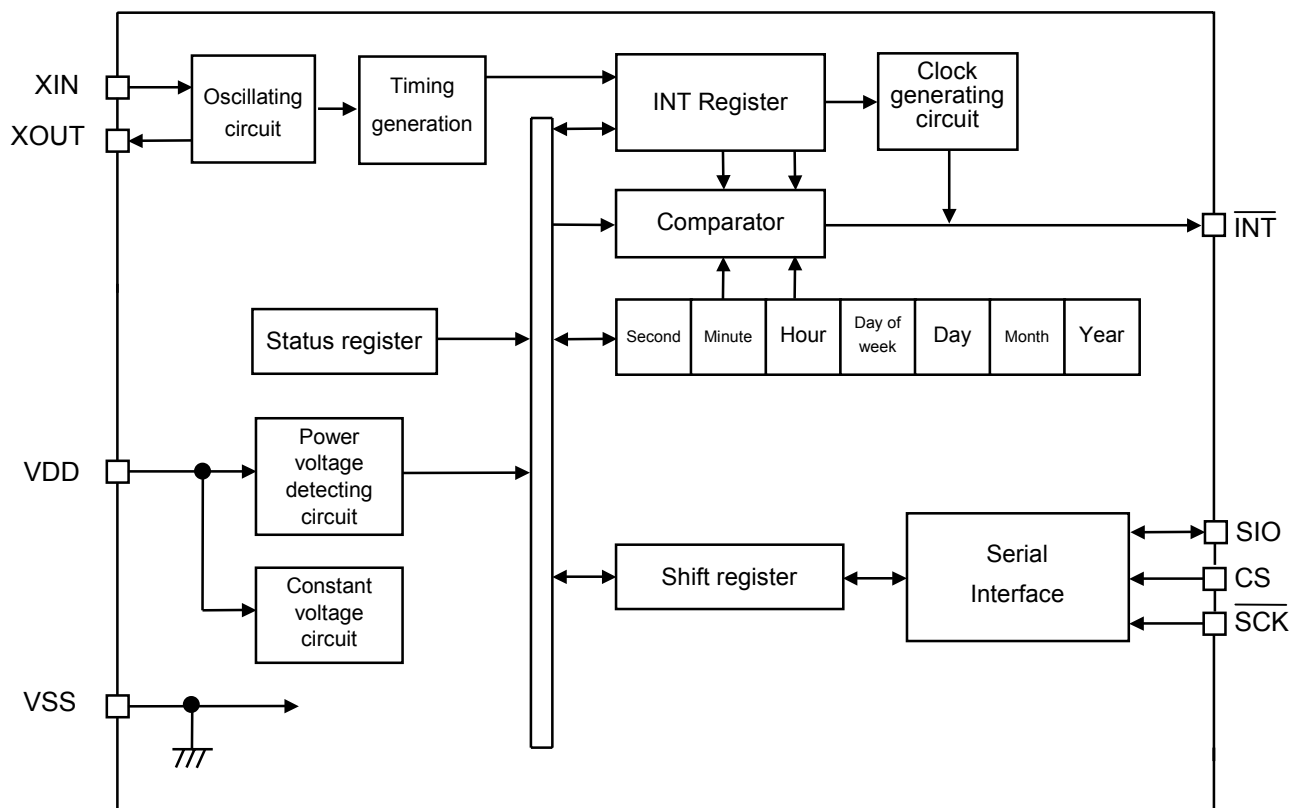
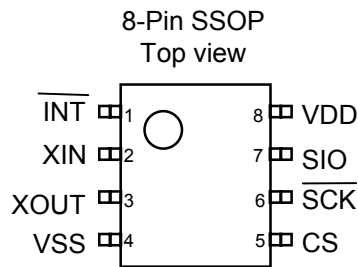

Figure 1 Block diagram

■ Pin Assignment

(1) Package :

S-3511AEFS



S-3511AEFJ

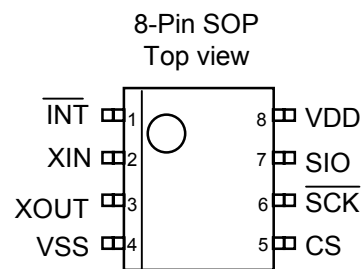
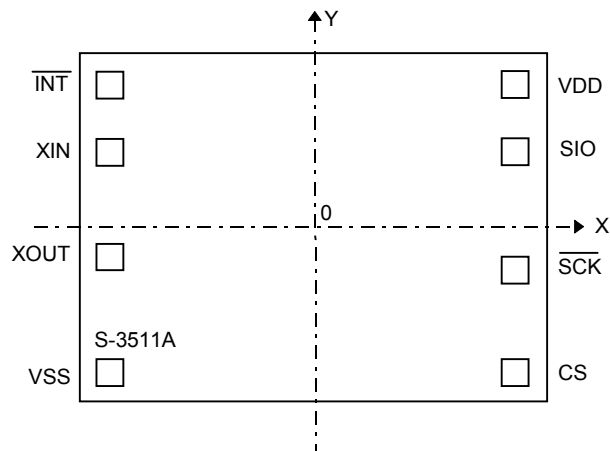

Figure 2 Pin assignment

(2) Die :

S-3511AECA



**Remark 1.** Die size : 2.10 × 1.60 mm  
 Sizes shown are for design purposes only.  
 The corners of the die shrink by approximately 30 μm after dicing.

2. Pad size: 100 × 100 μm

Pad Coordinates

Symbol	X-Coordinate	Y-Coordinate	Symbol	X-Coordinate	Y-Coordinate
INT	-890	641	VDD	890	641
XIN	-890	351	SIO	890	356
XOUT	-890	-114	SCK	890	-240
VSS	-890	-641	CS	890	-641

Figure 2-2 Pad assignment

## ■ Description of Pins

**Table 1 Description of pins**

Pin No.	Symbol	Description	Configuration
1	$\overline{\text{INT}}$	Alarm interrupt output pin. Depending on the mode set by the INT register and status register, it outputs low or Clock when time is reached. It is disabled by rewriting the status register.	N-channel open drain output (No protective diode on the side of VDD)
2	XIN	Crystal oscillator connect pin (32,768 Hz) (Internal $C_d$ , External $C_g$ )	—
3	XOUT		
4	VSS	Negative power supply pin (GND)	—
5	CS	Chip select input pin. During "H" : The SIO pin allows data input/output. The $\overline{\text{SCK}}$ pin allows data input. During "L" : The SIO pin is in the High-Z state. The $\overline{\text{SCK}}$ pin is in the input-disabled state.	CMOS input (Included pull-down resistance. No protective diode on the side of VDD)
6	$\overline{\text{SCK}}$	Serial clock input pin. The input/output of data from the SIO pin is performed in synchronization with this clock. However, the clock is not accepted while the CS pin is "L".	CMOS input (No protective diode on the side of VDD)
7	SIO	Serial data input/output pin. It is normally in the High-Z state while the CS pin is "L". When the CS pin changes from "L" to "H", the SIO pin is set to an input pin. It will be set to an input or output pin, depending on an subsequently input command.	N-channel open drain output (No protective diode on the side of VDD) CMOS input
8	VDD	Positive power supply pin.	—

■ Description of Operation

1. Serial interface

S-3511A receives various commands via a three-wire serial interface to read/write data. This section covers the transfer methods of this product.

1-1. Data reading

When you input data from the SIO pin in synchronization with the falling of the  $\overline{SCK}$  pin after turning the CS pin to "H", the data is included into the inside of S-3511A at the eighth rising of the SCK clock and the state of data reading is reached when the R/W bit has "1". The state leads to output of data corresponding each command in synchronization with the falling of subsequent SCK clock input.

**Remark** When the number of SCK clocks is less than eight, the state of clock waiting is reached and no processing is done.

When SCK clocks are more than required, they are processed in order from the first and the clocks other than those required are ignored.

(1) Real-time data reading 1

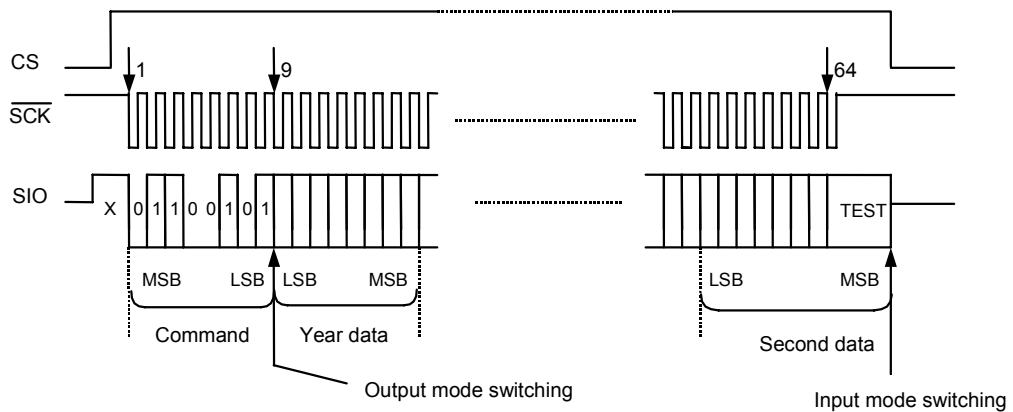

(2) Real-time data reading 2

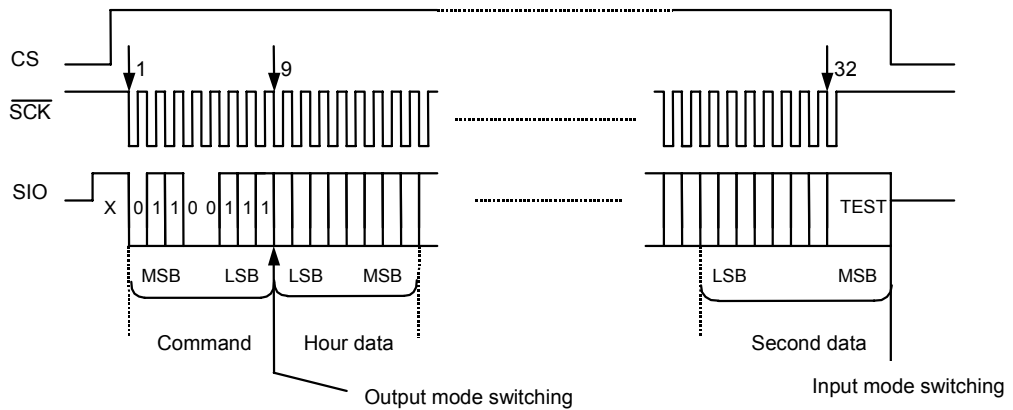

(3) Status register reading

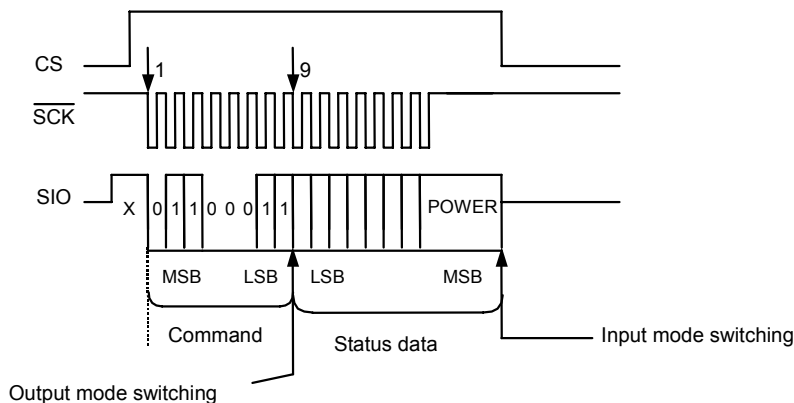
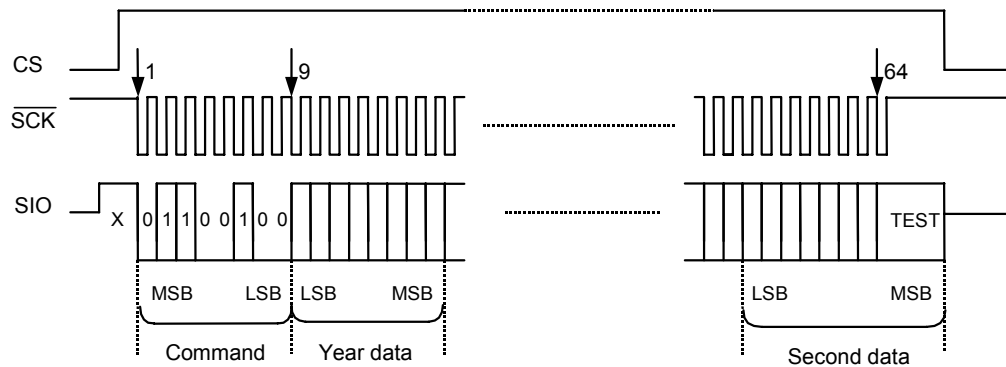

Figure 3 Read communication

**1-2. Data writing**

When you input data from the SIO pin in synchronization with the falling of the  $\overline{\text{SCK}}$  pin after turning the CS pin to "H", the data is included into the inside of S-3511A at the eighth rising of the SCK clock and the state of data writing is reached when the R/W bit has "0". In the state, the data is written to registers according each command in synchronization with the falling of subsequent SCK clock input.

**(1) Real-time data writing 1**



**(2) Real-time data writing 2**

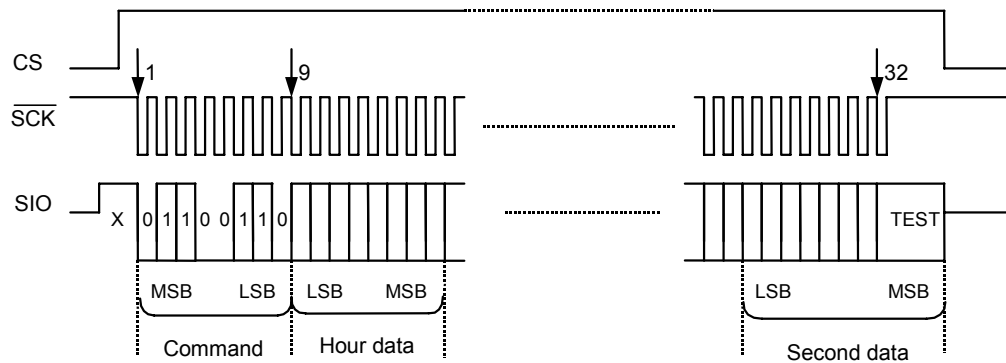

**(3) Status register writing**

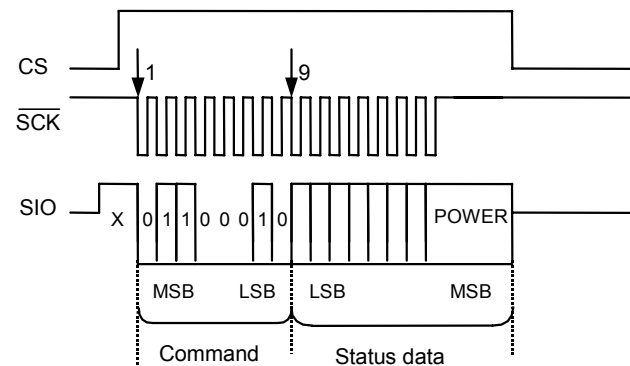

**Figure 4 Write communication**

### 1-3. Communication data configuration

After turning the CS pin to “H”, send four-bit fixed code “0110” and succeedingly transfer the command of a 3-bit length and read/write command of a one-bit length.

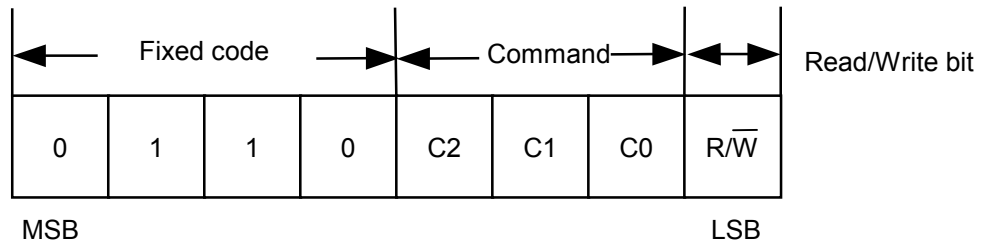

Figure 5 Communication data

## 2. Command configuration

There are seven types of commands which read from and write to various registers. The table below lists them. Any command that is not listed in the table provides no operation.

Table 2 Command list

C2	C1	C0	Description
0	0	0	Reset (00 (year), 01 (month), 01 (day), 0 (day of week), 00 (minute), 00 (second)) <sup>*1</sup>
0	0	1	Status register access
0	1	0	Real-time data access 1 (year data to)
0	1	1	Real-time data access 2 (hour data to)
1	0	0	Alarm time/frequency duty setting
1	1	0	Test mode start <sup>*2</sup>
1	1	1	Test mode end <sup>*2</sup>

\*1. Don't care the R/W bit of this command.

\*2. This command is access-disabled due to specific use for the IC test.

**2-1. Real-time data register**

The real-time data register is a fifty-six-bit register which stores the BCD code of the data of year, month, day, day of week, hour, minute and second. Any read/write operation performed by the real-time data access command sends or receives the data from LSB on the first digit of the year data.

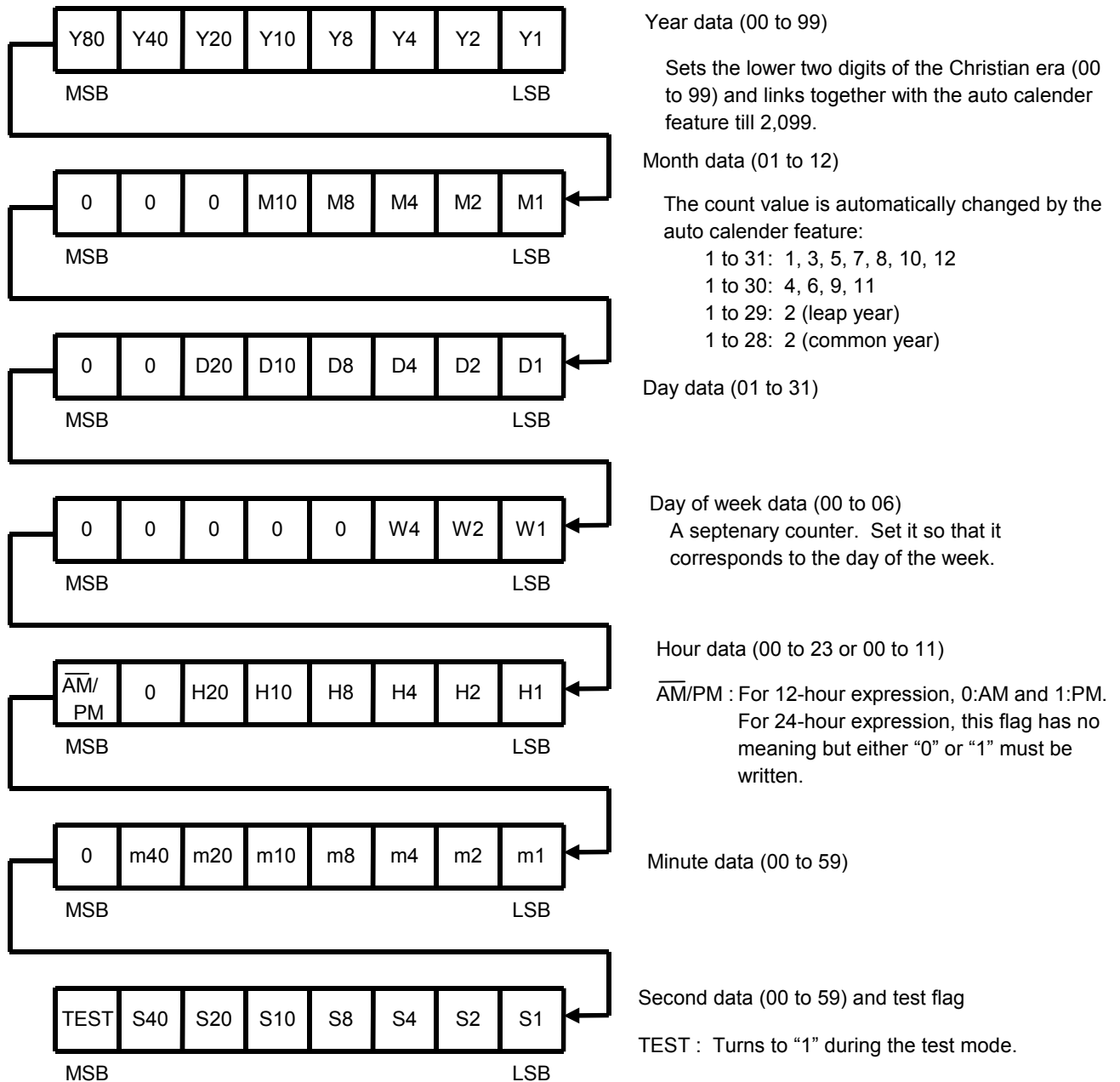

**Figure 6 Real-time data register**

## 2-2. Status register

The status register is an eight-bit register which allows you to display and set various modes. The POWER flag is read-only and others are read/write-enabled.

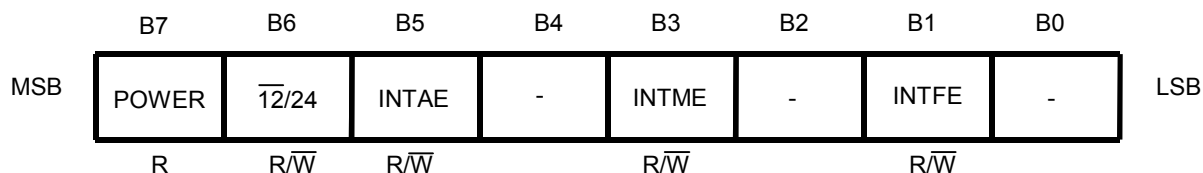

**Figure 7 Status register**

- B7:POWER** This flag turns to "1" if the power voltage detecting circuit operates during power-on or changes in power voltage (below  $V_{DET}$ ). Once turning to "1", this flag does not turn back to "0" even when the power voltage reaches or exceeds the detection voltage. When the flag is "1", you must send the reset command (or the status register read command), and turn it to "0". It is a read-only flag.
- B6: $\overline{12/24}$**  This flag is used to set 12-hour or 24-hour expression.  
 0 : 12-hour expression  
 1 : 24-hour expression
- B5:INTAE** This flag is used to choose the state of  $\overline{INT}$  pin output with alarm interrupt output set. Enable this flag after setting alarm time that forms a meeting condition in the INT register:  
 0 : Alarm interrupt output is disabled.  
 1 : Alarm interrupt output is enabled.
- B3:INTME** This flag is used to make the output of the  $\overline{INT}$  pin per-minute edge interrupt or per-minute steady interrupt. To make the output per-minute steady interrupt, set "1" at INTME and INTFE .  
 0 : Alarm interrupt or selected frequency steady interrupt output  
 1 : Per-minute edge interrupt or per-minute steady interrupt output
- B1:INTFE** This flag is used to make the output of the  $\overline{INT}$  pin per-minute steady interrupt output (a period of one minute, 50 % of duty) or selected frequency steady interrupt. Note that the INT register is considered as the data of frequency/duty if selected frequency steady interrupt is chosen.  
 0 : Alarm interrupt or per-minute edge interrupt output  
 1 : Per-minute steady interrupt or selected frequency steady interrupt output
- B4,B2 and B0:** If having written contents, they are ignored. When they are read, "0" can be read from them.

**2-3. Alarm time/Frequency duty setting register**

The alarm time/frequency duty setting registers is a sixteen-bit registers which sets alarm time or frequency duty. They are switched by INTAE or INTFE register. AM/PM flag to be set must be in accordance with 12-hour or 24-hour expression. If AM/PM flag is not rightly then set hour data is not met to alarm data. The alarm time/frequency duty setting register is a write-only register.

**(1) When INTAE = 1**

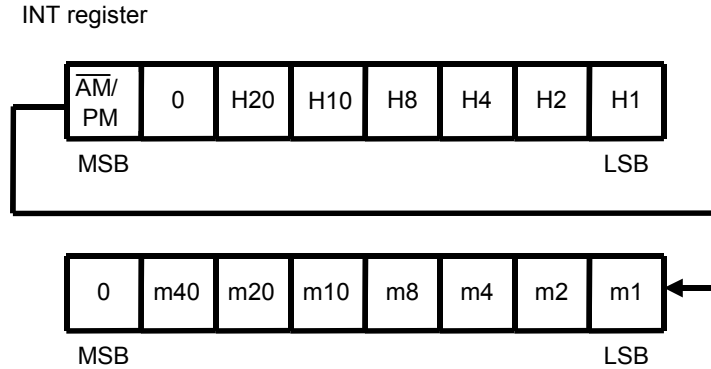
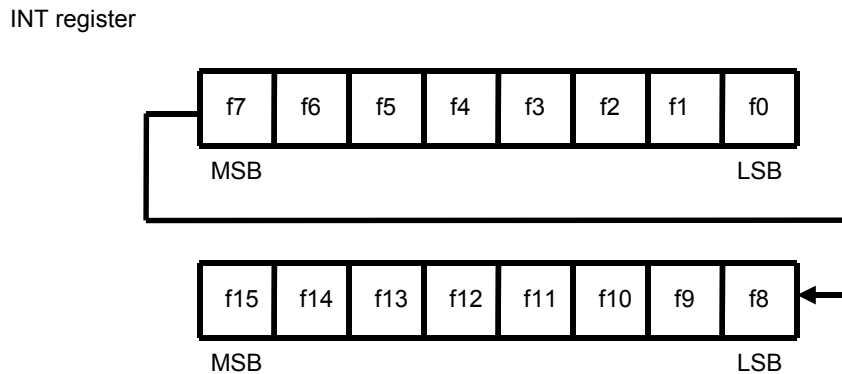

**Figure 8 INT register (alarm)**

INT register is considered as alarm time data. Having the same configuration as the time and minutes registers of real-time data register configuration, they represent hours and minutes with BCD codes. When setting them, do not set any none-existent day. Data to be set must be in accordance with 12-hour or 24-hour expression that is set at the status register.

**(2) When INTFE = 1**

INT register is considered as frequency duty data. By turning each bit of the registers to "1", a frequency corresponding to each bit is chosen in an ANDed form.



f0	32768 Hz	f4	2048 Hz	f8	128 Hz	f12	8 Hz
f1	16384 Hz	f5	1024 Hz	f9	64 Hz	f13	4 Hz
f2	8192 Hz	f6	512 Hz	f10	32 Hz	f14	2 Hz
f3	4096 Hz	f7	256 Hz	f11	16 Hz	f15	1 Hz

**Figure 9 INT register (frequency duty)**

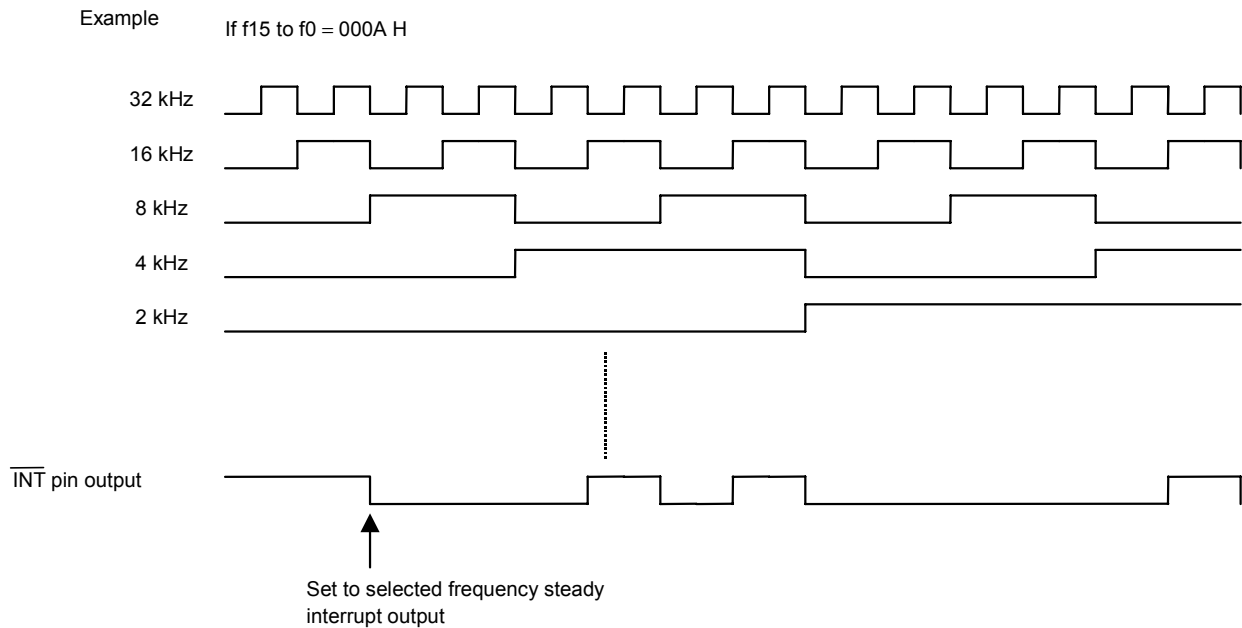

Figure 10 Clock output

## 2-4. Test flag

The test flag is a one-bit register which is assigned to MSB of the second data of the real-time data register. If transferred data is considered as the test mode starting command due to the receiving of the test mode starting command or noises, "1" is set. When "1" is set, you must send the test mode ending command or reset command.

## 3. Initialization

Note that S-3511A has different initializing operations, depending on states.

### 3-1. When power is turned on

When power is turned on, the status register is set to "82h" and the INT register to "8000h" by the power-on detecting circuit. In other words, "1" is sets at the bit 7 (POWER flag) of the status register and the clock of 1 Hz is output from the INT pin. This is provided to adjust oscillating frequencies. In normal use, the reset command must be sent when power is turned on.

Real-time data register	: 00 (year), 01 (month), 01 (day), 0 (day of week), 00 (hour), 00 (minute), 00 (second)
Status register	: "82h"
INT register	: "8000h"

### 3-2. When the power voltage detecting circuits operates

The power voltage detecting circuit included in S-3511A operates and sets "1" at the bit 7 (POWER flag) of the internal status register when power is turned on or power voltage is reduced. Once "1" is set, it is held even after the power voltage gets equal to or higher than the detection voltage, i.e., power voltage detector threshold. When the flag has "1", you must send the reset command from CPU and initialize the flag. At this point, other registers does not change. However, if the POWER flag has "0" during the power-on reset of CPU (S-3511A does not reach any indefinite area during backup), you do not have to send the reset command.

**3-3. When the reset command is received**

When the reset command is received, each register turns as follows:

Real-time data register : 00 (year), 01 (month), 01 (day), 0 (day of week), 00 (hour), 00 (minute), 00 (second)  
 Status register : "00h"  
 INT register : "0000h"

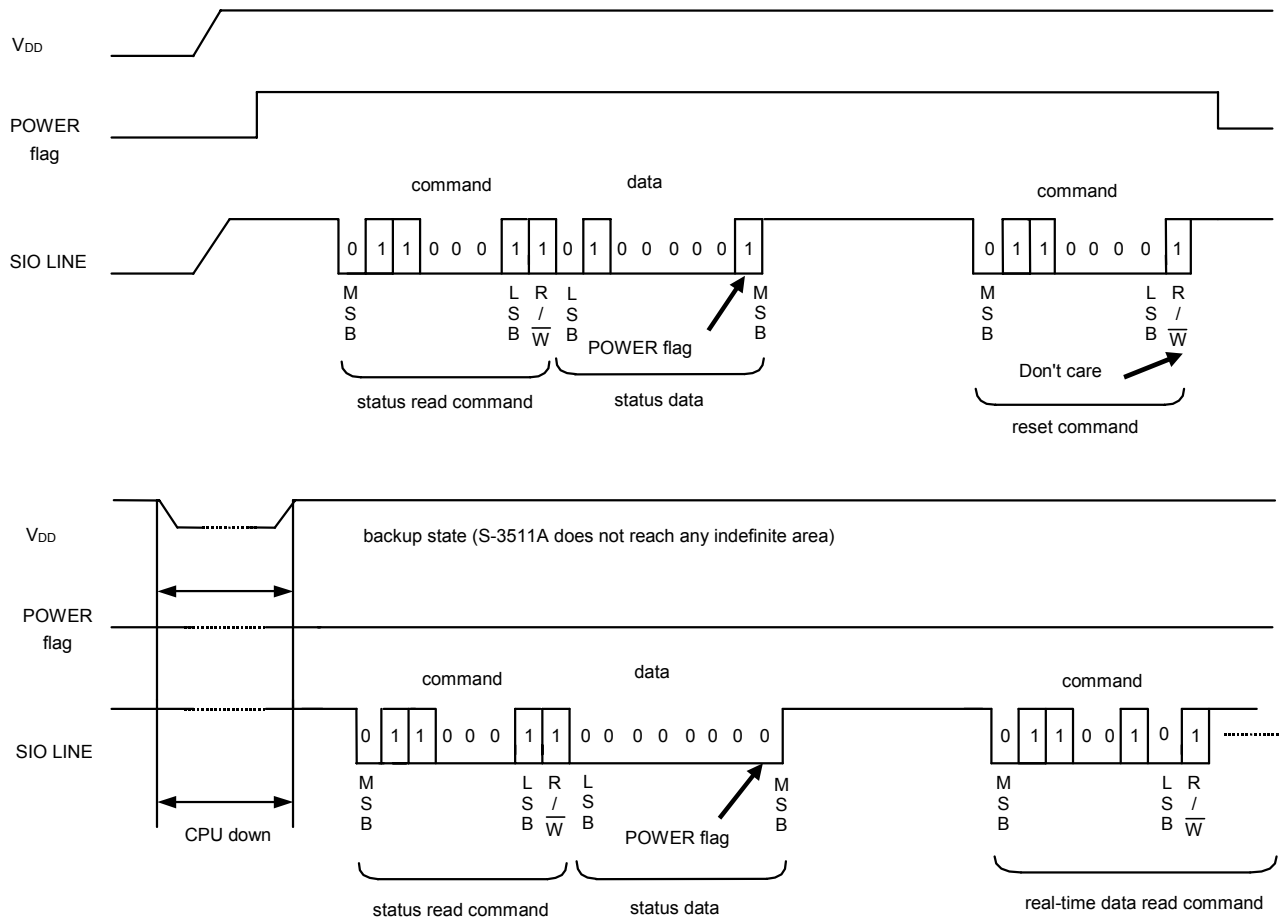

**Figure 11 Initializing**

#### 4. Processing of none-existent data and end-of-month

When writing real-time data, validate it and treat any invalid data and end-of-month correction.

[None-existent data processing]

**Table 3 None-existent data processing**

Register	Normal data	Error data	Result
Year data	00 to 99	XA to XF, AX to FX	00
Month data	01 to 12	00, 13 to 19, XA to XF	01
Day data	01 to 31	00, 32 to 39, XA to XF	01
Day of week data	0 to 6	7	0
Hour data (24-hour) *1 (12-hour)	0 to 23 0 to 11	24 to 29, 3X, XA to XF 12 to 19, XA to XF	00 00
Minute data	00 to 59	60 to 79, XA to XF	00
Second data *2	00 to 59	60 to 79, XA to XF	00

\*1. For 12-hour expression, write the AM/PM flag.  
The AM/PM flag is ignored in 24-hour expression, but "0" for 0 to 11 o'clock and "1" for 12 to 23 o'clock are read in a read operation.

\*2. None-existent data processing for second data is performed by a carry pulse one second after the end of writing. At this point, the carry pulse is sent to the minute counter.

[End-of-month correction]

Any none-existent day is corrected to the first day of the next month. For example, February 30 is changed to March 1. Leap-year correction is also performed here.

#### 5. Interrupt

There are five types of output format from the INT pin, which are selected by the INTAE, INTME and INTFE bits of the status register .

##### (1) Alarm interrupt output

Alarm interrupt is enabled by setting hour and minute data to the INT register and turning the status register's INTAE to "1" and INTME and INTFE to "0". When set hour data is met, low is output from the INT pin. Since the output is held, rewrite INTAE of the status register to "0" through serial communication to turn the output to high (OFF state). The coincidence signal retains for one minute. Pay attention that the "Low" signal is output from the INT pin once again when DISABLE or ENABLE communication is executed during this one-minute period.

##### (2) Selected frequency steady interrupt output

When you set frequency/duty data to the INT register and turn the status register's INTME to "0" and INTFE to "1", clock set at the INT register is output from the INT pin.

##### (3) Per-minute edge interrupt output

When a first minute carry is performed after the status register's INTME is set with "1" and INTFE with "0", low is output from the INT pin. Since the output is held, rewrite INTAE, INTME and INTFE of the status register through serial communication. When you perform DISABLE or ENABLE communication while the minute carry processing signal is being retained (for 10 ms), "Low" signal is output from the INT pin again.

##### (4) Per-minute steady interrupt output

When a first minute carry is performed after the status register's INTME and INTFE are set with "1", clock is output from the INT pin with a period of one minute (50 % duty). When you perform DISABLE or ENABLE communication while the INT pin is at "L", "Low" signal is output from the INT pin again.

**Caution 1.** If changing an output mode, give care to the state of the INT register and output.

**2.** If per-minute edge interrupt output or per-minute steady interrupt output is chosen, the INT register have no meaning.

**Table 4 Interrupt description**

NO.	INTAE	INTME	INTFE	Description
0	0	0	0	Output disabled
1	*1	0	1	Selected frequency steady interrupt output
2	*1	1	0	Per-minute edge interrupt output
3	*1	1	1	Per-minute steady interrupt output
4	1	0	0	Alarm interrupt output

\*1. Don't care

**(1) Alarm interrupt output**

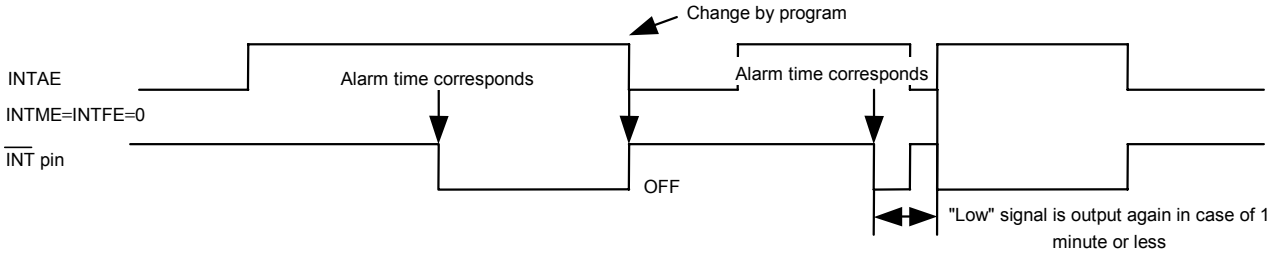

**(2) Selected frequency steady interrupt output**

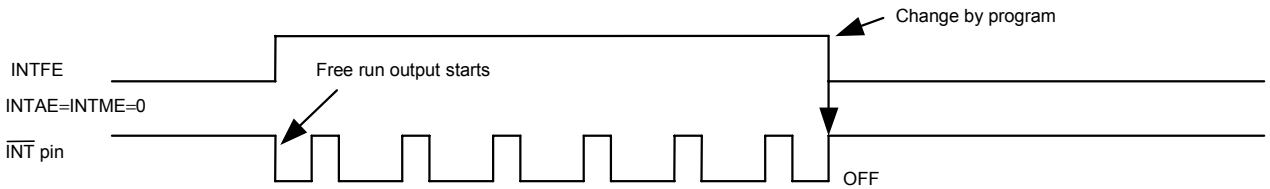

**(3) Per-minute edge interrupt output**

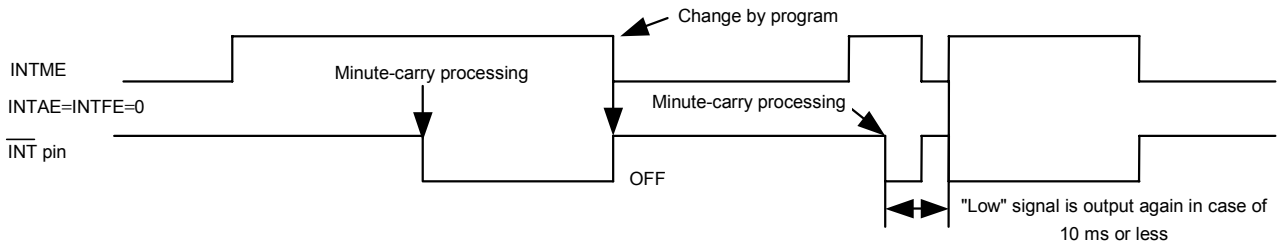

**(4) Per-minute steady interrupt output**

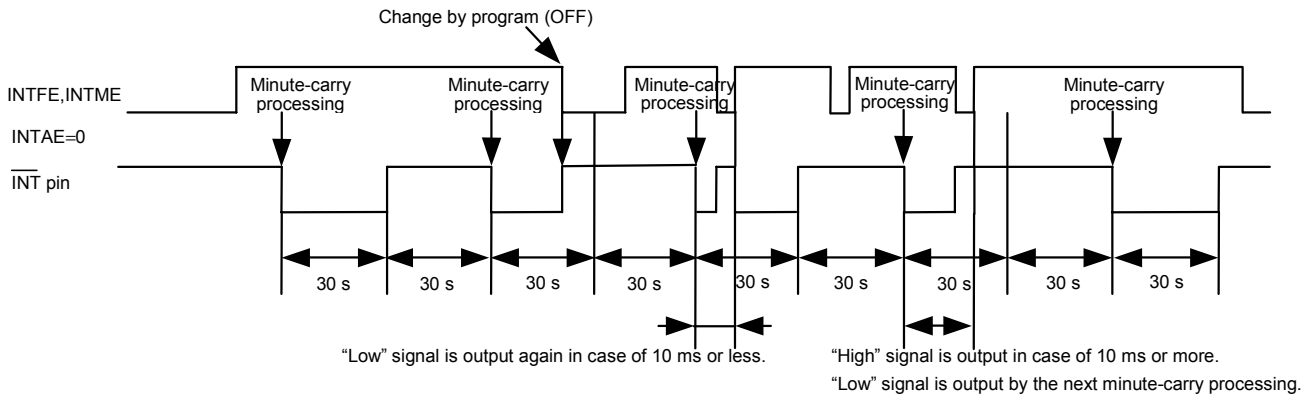

**(5) During power-on detecting circuit operation**

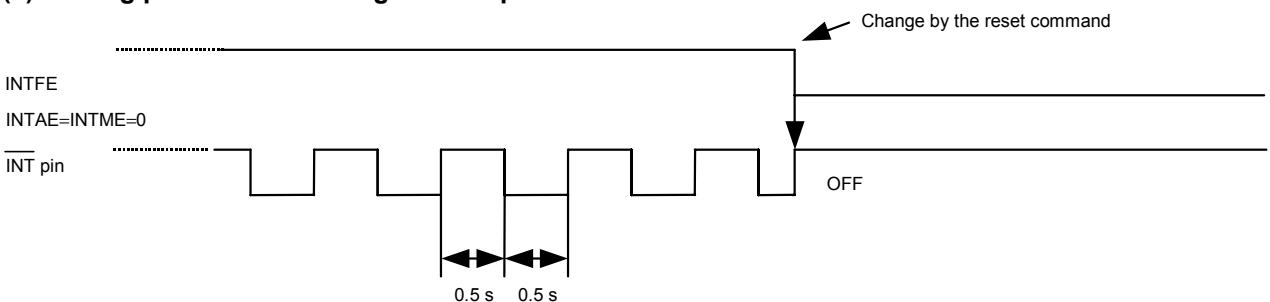

**Figure 12 Output mode**

**6. Power voltage detecting circuit**

S-3511 has an internal power voltage detecting circuit. This circuit gives sampling movement for only 15.6 ms once a second.

If the power voltage decreases below the detection voltage ( $V_{DET}$ ), the BLD latch circuit latches the "H" level, and sampling movement stops. Only when subsequent communication is of the status read command, the output of the latch circuit is transferred to the shift register and the sampling movement is resumed.

Decrease in power voltage can be monitored by reading the POWER flag.

That is to say, once decrease in power voltage is detected, any detecting operation is not performed and "H" is held unless you perform initialization or send the status read command.

**Caution** When power voltage is increased and the first read operation is performed after decrease in power voltage occurs and the latch circuit latches "H", "1" can be read on the POWER flag. However, if the next read operation is performed after the sampling of the detecting circuit, the POWER flag is reset since sampling is subsequently allowed. See the timing diagram below.

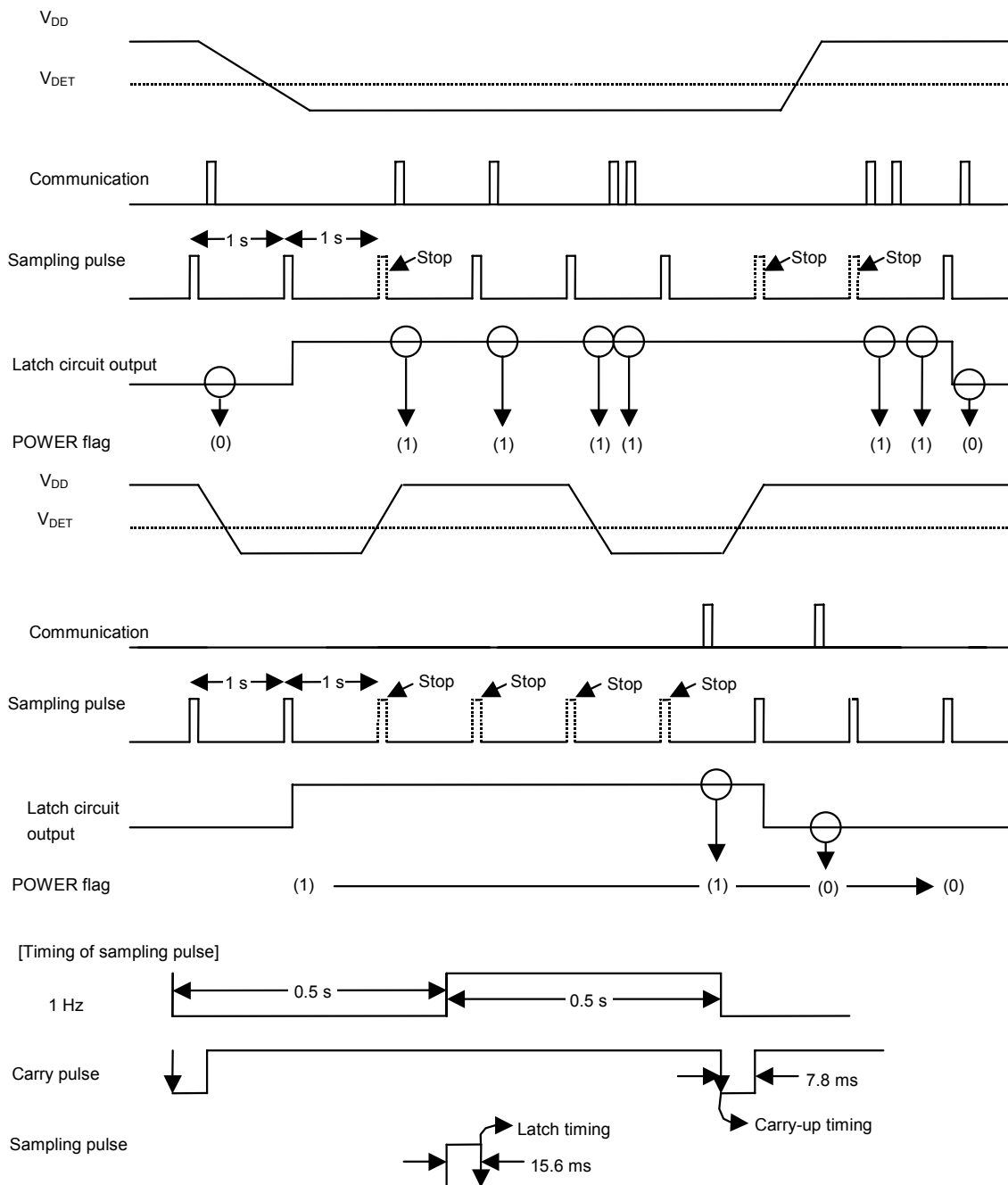

**Figure 13** Timing of the power voltage detecting circuit

7. Example of software treatment

(1) Initialization flow at power-on

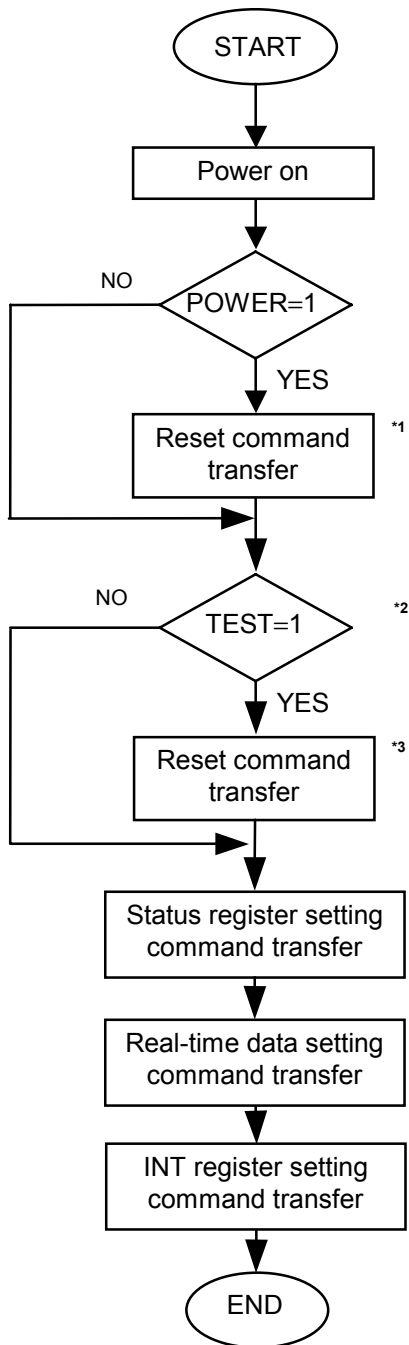

\*1. If S-3511 is back-up and power is turned on only on the CPU side, the reset command does not need transferring.

\*2. If conditions are no good (e.g., noise) and probable changes in commands occurs via serial communications, it is recommended to make sure the TEST flag.

\*3. The test ending command may be used alternately

Figure 14 Initialization flow

■ Samples of Applied Circuits

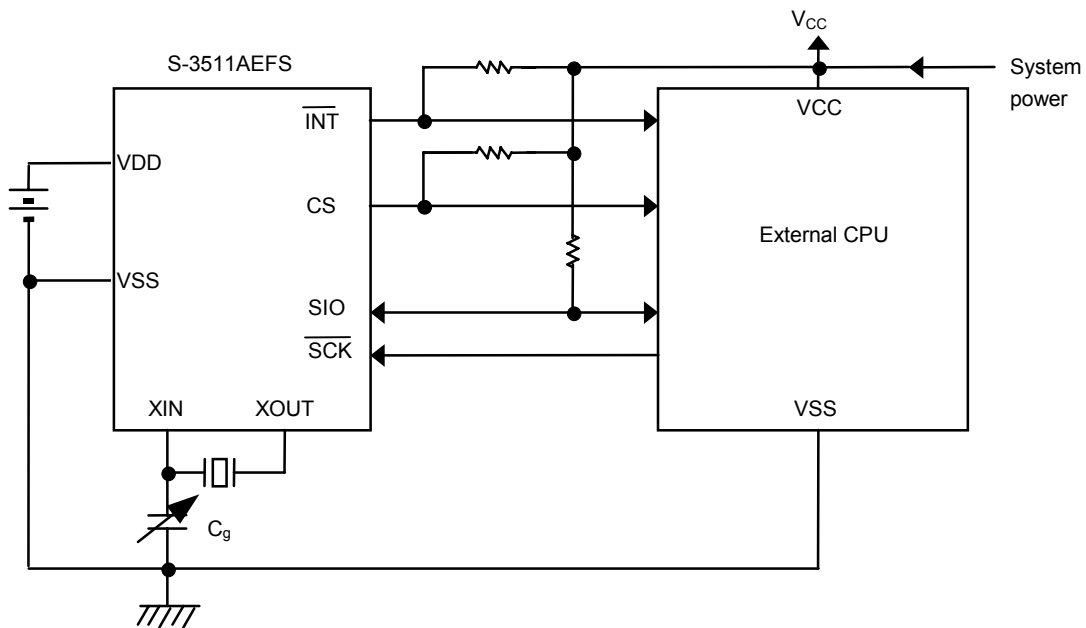

Due to the I/O pin with no protective diode on the VDD side, the relation of  $VCC \geq VDD$  has no problem. But give great care to the standard. Make communications after the system power is turned on and a stable state is obtained.

Figure 15 Applied circuit 1

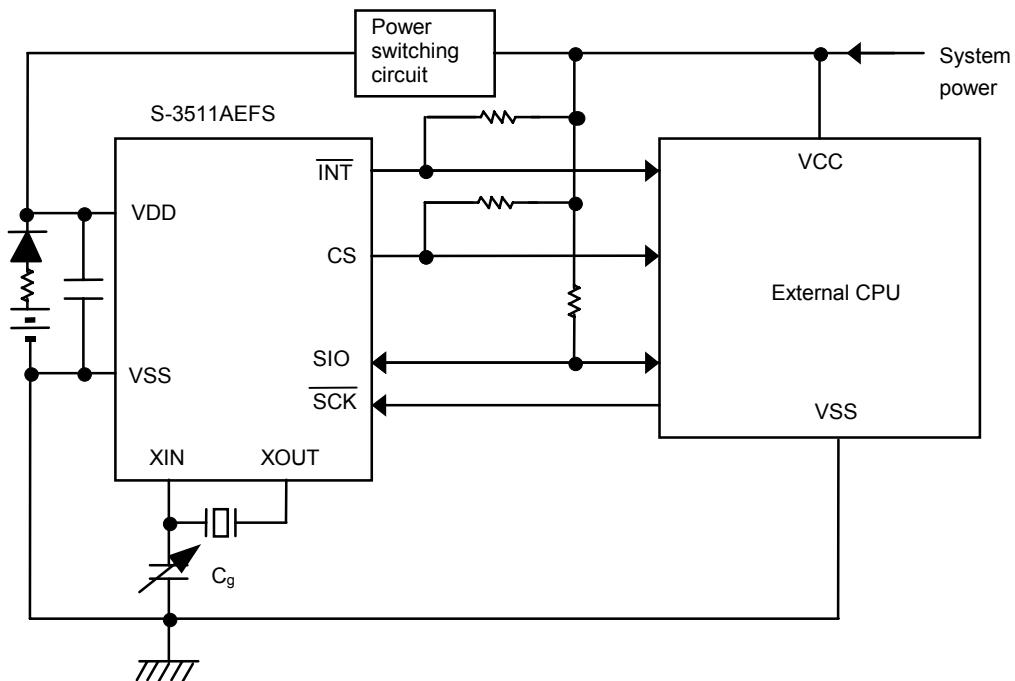

Make communications after the system power is turned on and a stable state is obtained.

Figure 16 Applied circuit 2

### Order Specification

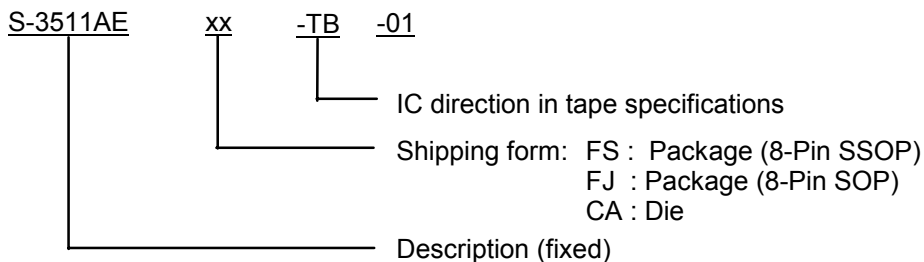

### ■ Adjustment of Oscillating Frequency

#### 1. Configuration of the oscillating circuit

Since crystal oscillation is sensitive to external noises (clock accuracy is affected), the following measures are essential for optimizing your oscillating circuit configuration:

- (1) S-3511A, crystal oscillator and external capacitor ( $C_g$ ) are placed as close to each other as possible.
- (2) Make high the insulation resistance between pins and the substrate wiring patterns of XIN and XOUT.
- (3) Do not place any signal or power lines close to the oscillating circuit.

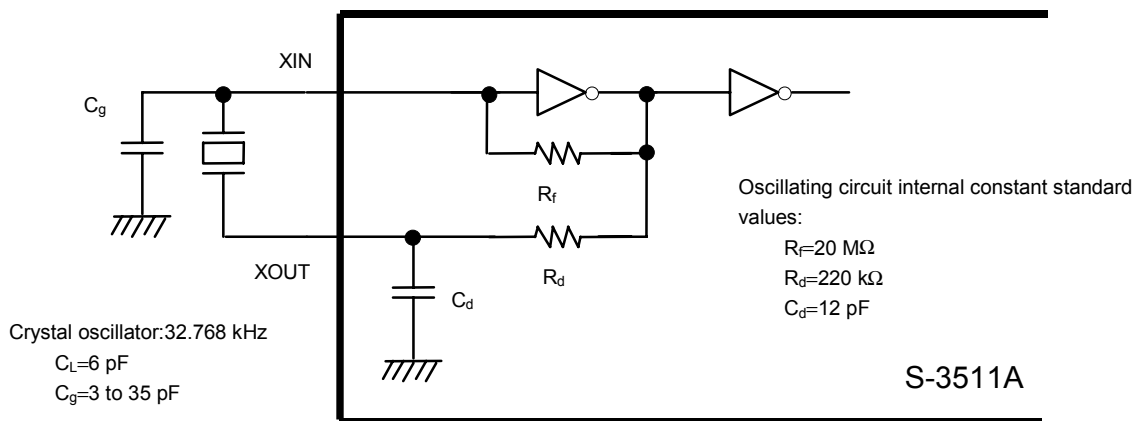

Figure 17 Connection diagram

## 2. Measurement of oscillating frequencies

When power is turned on, S-3511A has the internal power-on detecting circuit operating and outputs a signal of 1 Hz from the INT pin to select the crystal oscillator and optimize the  $C_g$  value. Turn power on and measure the signal with a frequency counter following the circuit configuration shown in **Figure 18**.

**Remark** If the error range is  $\pm 1$  ppm in relation to 1 Hz, time is shifted by approximately 2.6 seconds a month:

$$10^{-6} (1 \text{ ppm}) \times 60 \text{ seconds} \times 60 \text{ minutes} \times 24 \text{ hours} \times 30 \text{ days} = 2.592 \text{ seconds}$$

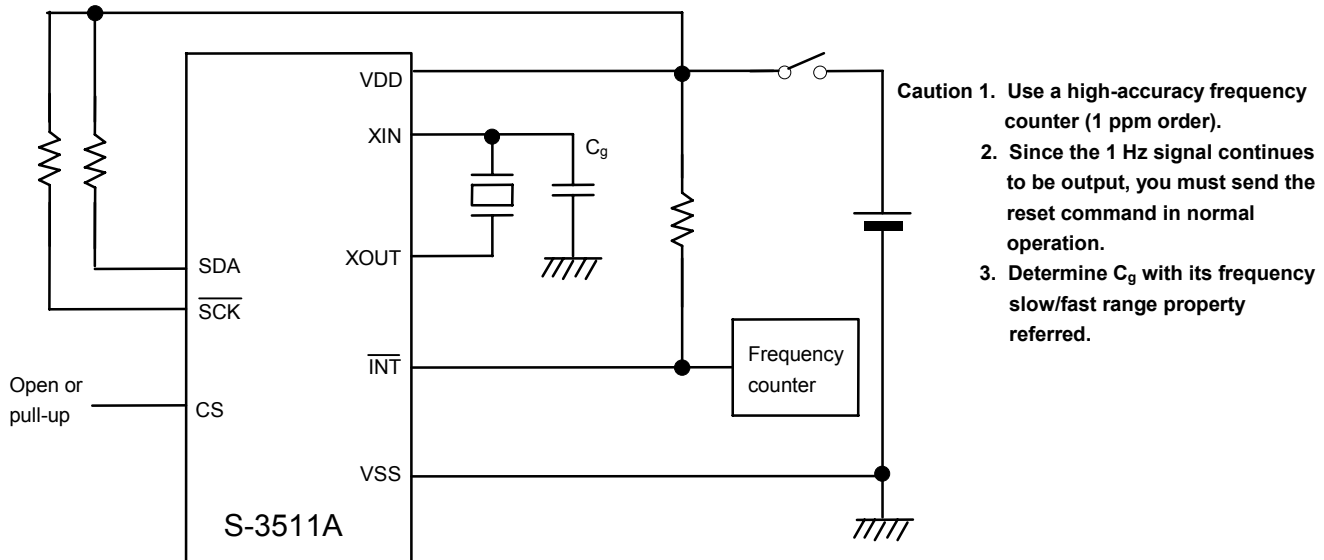
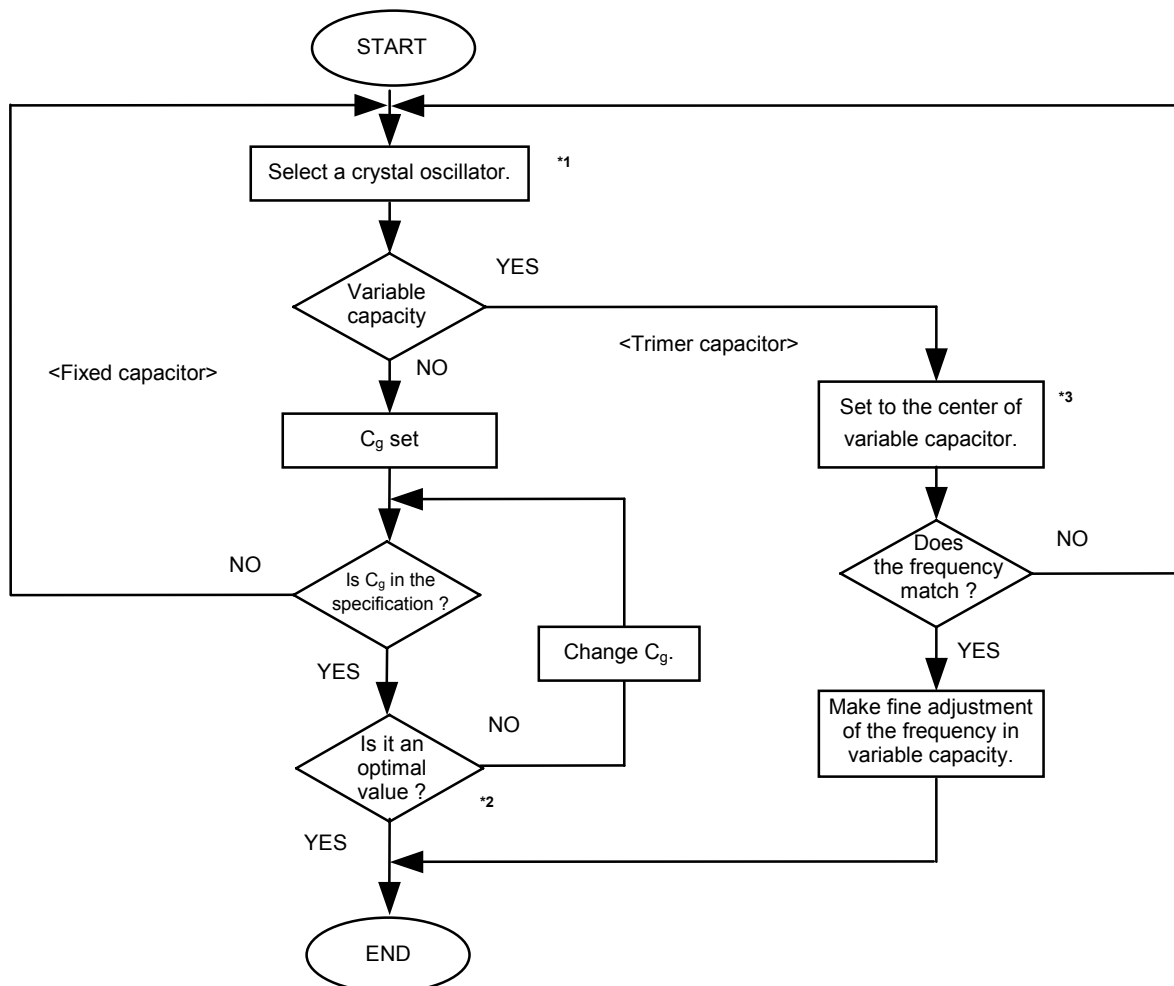

Figure 18 Connection diagram

### 3. Adjustment of oscillating frequencies

Matching of a crystal oscillator with the nominal frequency must be performed with parasitic capacitance on the board included. Select a crystal oscillator and optimize the  $C_g$  value in accordance with the flow chart below.



- \*1. For making matching adjustment of the IC with a crystal, contact an appropriate crystal maker to determine the  $C_L$  value (load capacity) and  $R_1$  value (equivalent serial resistance). The  $C_L$  value = 6 pF and  $R_1$  value = 30 k $\Omega$  Typ. are recommended values.
- \*2.  $C_g$  value selection must be performed on the actual PCB since parasitic capacitance affects it. Select the  $C_g$  value in a range from 3 pF to 35 pF. If the frequency does not match, change the  $C_L$  value of the crystal.
- \*3. Adjust the rotation angle of the variable capacity so that the capacity value is somewhat smaller than the center, and confirm the oscillating frequency and the center value of the variable capacity. This is done in order to make the capacity of the center value smaller than one half of the actual capacity value because a smaller capacity value makes a greater quantity of changes in a frequency. If the frequency does not match, change the  $C_L$  value of the crystal.

**Caution 1. Oscillating frequencies are changed by ambient temperature and power voltage. Refer to property samples.**

2. The 32 kHz crystal oscillator operates slower at higher or lower ambient temperature than 20 to 25°C. Therefore, it is recommended to adjust or set the oscillator to operate somewhat faster at normal temperature.

## ■ Absolute Maximum Ratings

**Table 5 Absolute maximum ratings**

Item	Symbol	Rating	Unit	Applicable pin, conditions
Power voltage	$V_{DD}$	-0.3 to +6.5	V	—
Input voltage	$V_{IN}$	-0.3 to +6.5	V	SCK, SDA, CS
Output voltage	$V_{OUT}$	-0.3 to +6.5	V	SIO, INT
Operating temperature	$T_{opr}$	-40 to +85	°C	$V_{DD}=3.0\text{ V}$
Storage temperature	$T_{stg}$	-55 to +125	°C	—

**Caution** The absolute maximum ratings are rated values exceeding which the product could suffer physical damage. These values must therefore not be exceeded under any conditions.

## ■ Recommended Operating Conditions

**Table 6 Recommended operating conditions**

Item	Symbol	Condition	Min.	Typ.	Max.	Unit
Power voltage	$V_{DD}$	—	1.7	3.0	5.5	V
Operating temperature	$T_{opr}$	—	-20	+25	+70	°C

## ■ Oscillation Characteristics

**Table 7 Oscillation characteristics**

( $T_a=25^\circ\text{C}$ ,  $V_{DD}=3\text{ V}$ , DS-VT-200 (crystal oscillator,  $C_L=6\text{ pF}$ , 32,768 Hz) manufactured by Seiko Instruments Inc.)

Item	Symbol	Condition	Min.	Typ.	Max.	Unit
Oscillation start voltage	$V_{STA}$	Within ten seconds	1.7	—	5.5	V
Oscillation start time	$T_{STA}$	—	—	—	1	s
IC-to-IC frequency diversity	$\delta IC$	—	-10	—	+10	ppm
Frequency voltage diversity	$\delta V$	$V_{DD}=1.7\text{ to }5.5\text{ V}$	-3	—	+3	ppm/V
Input capacity	$C_g$	Applied to the XIN pin	3	—	35	pF
Output capacity	$C_d$	Applied to the XOUT pin	—	12	—	pF

## ■ DC Electrical Characteristics

**Table 8 DC characteristics (3 V)**

(Ta=25°C, V<sub>DD</sub>=3 V, DS-VT-200 (crystal oscillator, C<sub>L</sub>=6 pF, 32,768 Hz) manufactured by Seiko Instruments Inc.)

Item	Symbol	Condition	Min.	Typ.	Max.	Unit	Applicable pin
Range of operating voltage	V <sub>DD</sub>	Ta= -20 to +70°C	1.7	3.0	5.5	V	—
Current consumption 1	I <sub>DD1</sub>	During no communications	—	0.7	1.5	μA	—
Current consumption 2	I <sub>DD2</sub>	During communications (SCK=100 kHz)	—	5.5	10	μA	—
Input leak current 1	I <sub>IZH</sub>	V <sub>IN</sub> = V <sub>DD</sub>	-0.5	—	0.5	μA	SCK, SIO
Input leak current 2	I <sub>IZL</sub>	V <sub>IN</sub> = V <sub>SS</sub>	-0.5	—	0.5	μA	SCK, SIO
Input current 1	I <sub>IL1</sub>	V <sub>IN</sub> = 5.5 V	2	6	20	μA	CS
Input current 2	I <sub>IL2</sub>	V <sub>IN</sub> = 0.4 V	40	110	300	μA	CS
Output leak current1	I <sub>OZH</sub>	V <sub>OUT</sub> =V <sub>DD</sub>	-0.5	—	0.5	μA	INT, SIO
Output leak current2	I <sub>OZL</sub>	V <sub>OUT</sub> =V <sub>SS</sub>	-0.5	—	0.5	μA	INT, SIO
Input voltage 1	V <sub>IH</sub>	—	0.8×V <sub>DD</sub>	—	—	V	SIO, SCK, CS
Input voltage 2	V <sub>IL</sub>	—	—	—	0.2×V <sub>DD</sub>	V	SIO, SCK, CS
Output current 1	I <sub>OL1</sub>	V <sub>OUT</sub> =0.4 V	1.5	2.5	—	mA	INT
Output current 2	I <sub>OL2</sub>	V <sub>OUT</sub> =0.4 V	5	10	—	mA	SIO
Power voltage detection voltage 1	V <sub>DET1</sub>	Ta=+25°C	1.8	2.0	2.2	V	—
Power voltage detection voltage 2	V <sub>DET2</sub>	Ta= -20 to +70°C	1.72	—	2.3	V	—

**Table 9 DC characteristics (5 V)**

(Ta=25°C, V<sub>DD</sub>=5 V, DS-VT-200 (crystal oscillator, C<sub>L</sub>=6 pF, 32,768 Hz) manufactured by Seiko Instruments Inc.)

Item	Symbol	Condition	Min.	Typ.	Max.	Unit	Applicable pin
Range of operating voltage	V <sub>DD</sub>	Ta= -20 to +70°C	1.7	3.0	5.5	V	—
Current consumption 1	I <sub>DD1</sub>	During no communications	—	1.6	3.0	μA	—
Current consumption 2	I <sub>DD2</sub>	During communications (SCK=100 kHz)	—	12	20	μA	—
Input leak current 1	I <sub>IZH</sub>	V <sub>IN</sub> = V <sub>DD</sub>	-0.5	—	0.5	μA	$\overline{\text{SCK}}$ , SIO
Input leak current 2	I <sub>IZL</sub>	V <sub>IN</sub> = V <sub>SS</sub>	-0.5	—	0.5	μA	$\overline{\text{SCK}}$ , SIO
Input current 1	I <sub>IL1</sub>	V <sub>IN</sub> = 5.5 V	10	25	50	μA	CS
Input current 2	I <sub>IL2</sub>	V <sub>IN</sub> = 0.4 V	100	175	400	μA	CS
Output leak current1	I <sub>OZH</sub>	V <sub>OUT</sub> =V <sub>DD</sub>	-0.5	—	0.5	μA	$\overline{\text{INT}}$ , SIO
Output leak current2	I <sub>OZL</sub>	V <sub>OUT</sub> =V <sub>SS</sub>	-0.5	—	0.5	μA	$\overline{\text{INT}}$ , SIO
Input voltage 1	V <sub>IH</sub>	—	0.8×V <sub>DD</sub>	—	—	V	SIO, $\overline{\text{SCK}}$ , CS
Input voltage 2	V <sub>IL</sub>	—	—	—	0.2×V <sub>DD</sub>	V	SIO, $\overline{\text{SCK}}$ , CS
Output current 1	I <sub>OL1</sub>	V <sub>OUT</sub> =0.4 V	2.0	3.5	—	mA	$\overline{\text{INT}}$
Output current 2	I <sub>OL2</sub>	V <sub>OUT</sub> =0.4 V	6	12	—	mA	SIO
Power voltage detection voltage 1	V <sub>DET1</sub>	Ta=+25°C	1.8	2.0	2.2	V	—
Power voltage detection voltage 2	V <sub>DET2</sub>	Ta= -20 to +70°C	1.72	—	2.3	V	—

## ■ AC Electrical Characteristics

**Table 10 AC characteristics 1**

(S-3511A,  $R_L=10\text{ k}\Omega$ ,  $C_L=80\text{ pF}$ )

Conditions :  $V_{DD}=1.7\text{ V to }5.5\text{ V}$ ,  $T_a=-20\text{ to }70^\circ\text{C}$

Input;  $V_{IH}=0.8 \times V_{DD}$ ,  $V_{IL}=0.2 \times V_{DD}$ , Output;  $V_{OH}=0.8 \times V_{CC}$ ,  $V_{OL}=0.2 \times V_{CC}$  ( $V_{CC}=5.0\text{ V}$ )

Item	Symbol	Min.	Typ.	Max.	Unit
Clock pulse width	$t_{SCK}$	5	—	250000	$\mu\text{s}$
Setup time before CS rising	$t_{DS}$	1	—	—	$\mu\text{s}$
Hold time after CS rising	$t_{CSH}$	1	—	—	$\mu\text{s}$
Input data setup time	$t_{ISU}$	1	—	—	$\mu\text{s}$
Input data hold time	$t_{IHO}$	1	—	—	$\mu\text{s}$
Output data definition time	$t_{ACC}$	—	—	3.5	$\mu\text{s}$
Setup time before CS falling	$t_{CSS}$	1	—	—	$\mu\text{s}$
Hold time after CS falling	$t_{DH}$	1	—	—	$\mu\text{s}$
Input rising/falling time	$t_R, t_F$	—	—	0.1	$\mu\text{s}$

**Caution** Since the output form of the SIO pin is N-channel open drain output, the rising time of  $t_{ACC}$  is determined by the values of load resistance ( $R_L$ ) and load capacity ( $C_L$ ) outside the IC. Use this as a reference value.

**Table 11 AC characteristics 2**

(S-3511A,  $R_L=10\text{ k}\Omega$ ,  $C_L=80\text{ pF}$ )

Conditions :  $V_{DD}=3.0 \pm 0.3\text{ V}$ ,  $T_a=-20\text{ to }70^\circ\text{C}$

Input;  $V_{IH}=0.8 \times V_{DD}$ ,  $V_{IL}=0.2 \times V_{DD}$ , Output;  $V_{OH}=0.8 \times V_{CC}$ ,  $V_{OL}=0.2 \times V_{CC}$  ( $V_{CC}=5.0\text{ V}$ )

Item	Symbol	Min.	Typ.	Max.	Unit
Clock pulse width	$t_{SCK}$	1	—	250000	$\mu\text{s}$
Setup time before CS rising	$t_{DS}$	0.2	—	—	$\mu\text{s}$
Hold time after CS rising	$t_{CSH}$	0.2	—	—	$\mu\text{s}$
Input data setup time	$t_{ISU}$	0.2	—	—	$\mu\text{s}$
Input data hold time	$t_{IHO}$	0.2	—	—	$\mu\text{s}$
Output data definition time	$t_{ACC}$	—	—	1.0	$\mu\text{s}$
Setup time before CS falling	$t_{CSS}$	0.2	—	—	$\mu\text{s}$
Hold time after CS falling	$t_{DH}$	0.2	—	—	$\mu\text{s}$
Input rising/falling time	$t_R, t_F$	—	—	0.05	$\mu\text{s}$

**Caution** Since the output form of the SIO pin is N-channel open drain output, the rising time of  $t_{ACC}$  is determined by the values of load resistance ( $R_L$ ) and load capacity ( $C_L$ ) outside the IC. Use this as a reference value.

Table 12 AC characteristics 3

(S-3511A,  $R_L=10\text{ k}\Omega$ ,  $C_L=80\text{ pF}$ )

Conditions :  $V_{DD}=5.0 \pm 0.5\text{ V}$ ,  $T_a=-20\text{ to }70^\circ\text{C}$

Input;  $V_{IH}=0.8 \times V_{DD}$ ,  $V_{IL}=0.2 \times V_{DD}$ , Output;  $V_{OH}=0.8 \times V_{CC}$ ,  $V_{OL}=0.2 \times V_{CC}$  ( $V_{CC}=5.0\text{ V}$ )

Item	Symbol	Min.	Typ.	Max.	Unit
Clock pulse width	$t_{SCK}$	0.5	—	250000	$\mu\text{s}$
Setup time before CS rising	$t_{DS}$	0.1	—	—	$\mu\text{s}$
Hold time after CS rising	$t_{CSH}$	0.1	—	—	$\mu\text{s}$
Input data setup time	$t_{ISU}$	0.1	—	—	$\mu\text{s}$
Input data hold time	$t_{IHO}$	0.1	—	—	$\mu\text{s}$
Output data definition time	$t_{ACC}$	—	—	0.3	$\mu\text{s}$
Setup time before CS falling	$t_{CSS}$	0.1	—	—	$\mu\text{s}$
Hold time after CS falling	$t_{DH}$	0.1	—	—	$\mu\text{s}$
Input rising/falling time	$t_R, t_F$	—	—	0.05	$\mu\text{s}$

**Caution** Since the output form of the SIO pin is N-channel open drain output, the rising time of  $t_{ACC}$  is determined by the values of load resistance ( $R_L$ ) and load capacity ( $C_L$ ) outside the IC. Use this as a reference value.

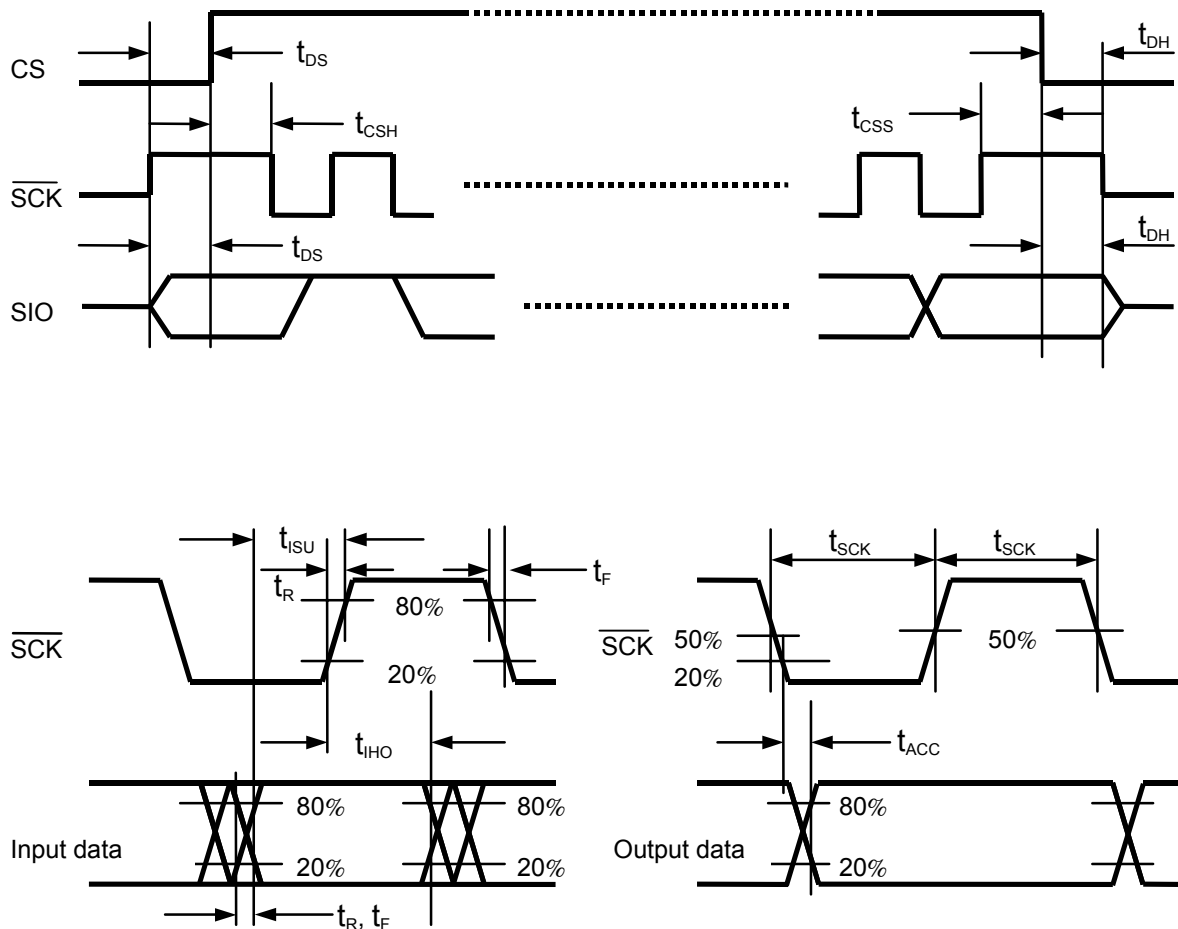

■ **Precaution**

Do not apply an electrostatic discharge to this IC that exceeds the performance ratings of the built-in electrostatic protection circuit.

■ Sample of Characteristics (Reference values)

(1) Standby current versus  $C_g$

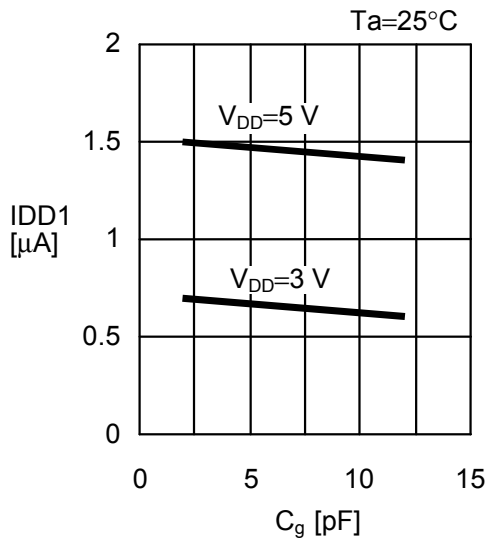

(2) Standby current versus  $V_{DD}$

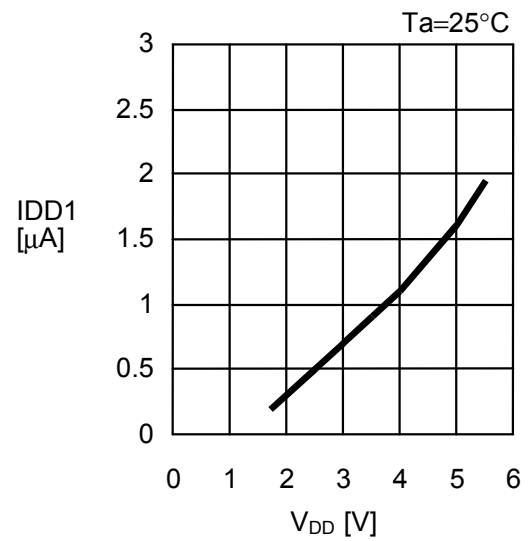

(3) Operating drain current versus Input clock

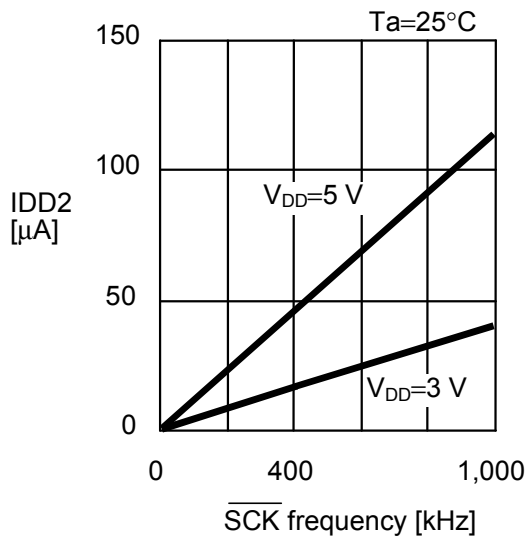

(4) Standby current versus temperature

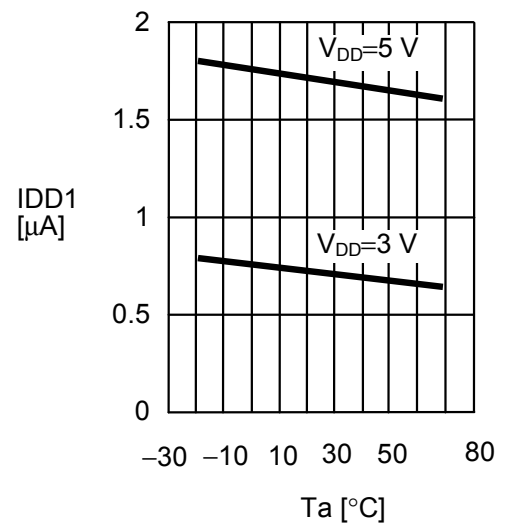

(5) Oscillating frequency versus  $C_g$

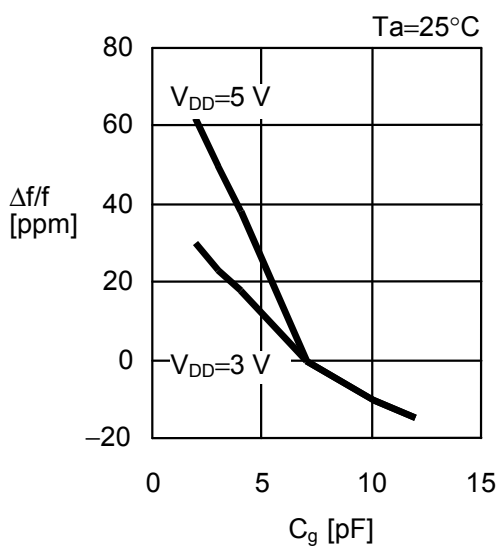

(6) Oscillating frequency versus  $V_{DD}$

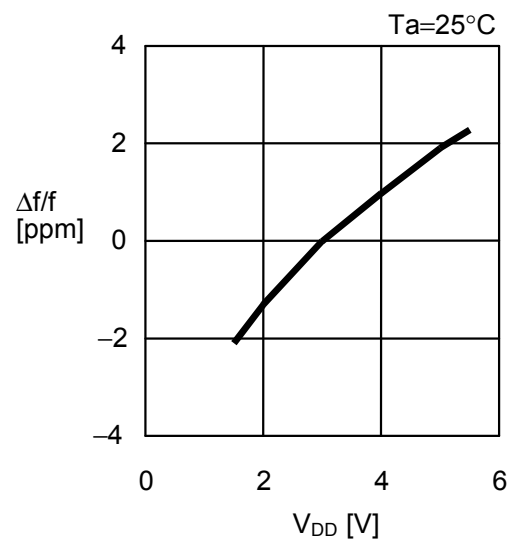

(7) Oscillating frequency versus temperature

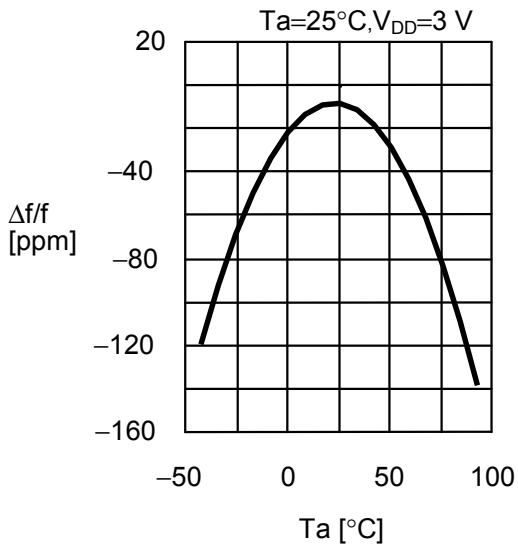

(8) Oscillation start time versus  $C_g$

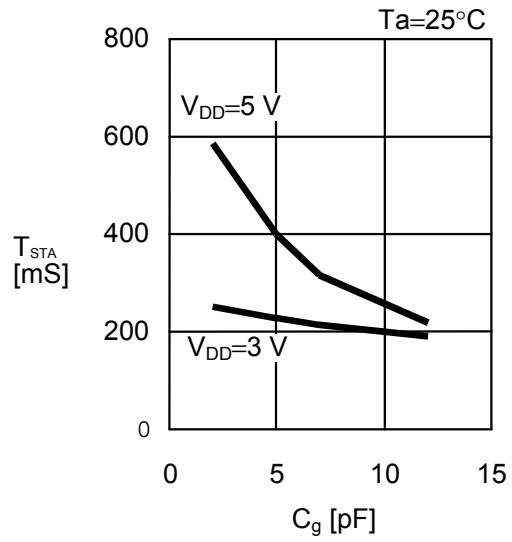

(9) Output current 1 ( $V_{OUT}$  versus  $I_{OL1}$ )

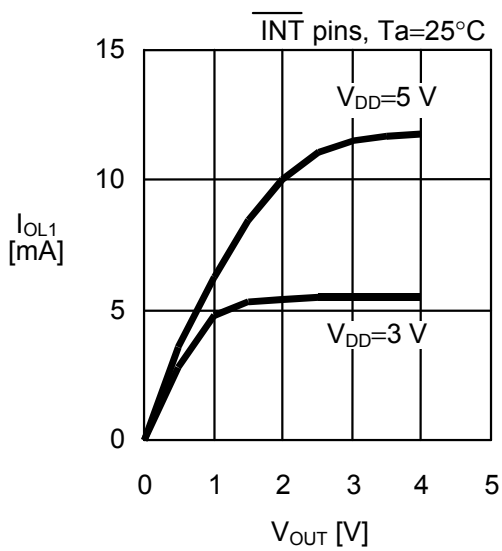

(10) Output current 2 ( $V_{OUT}$  versus  $I_{OL2}$ )

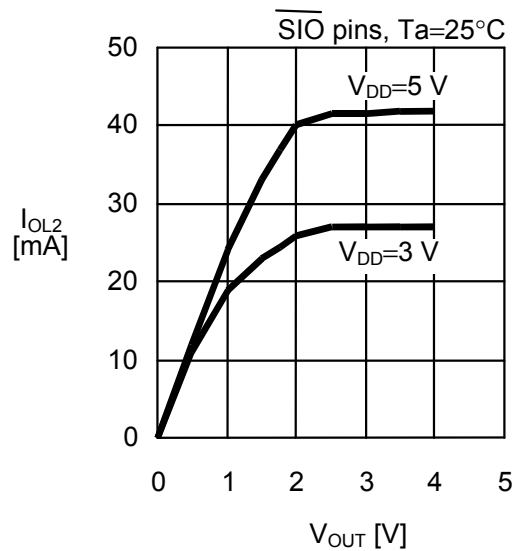

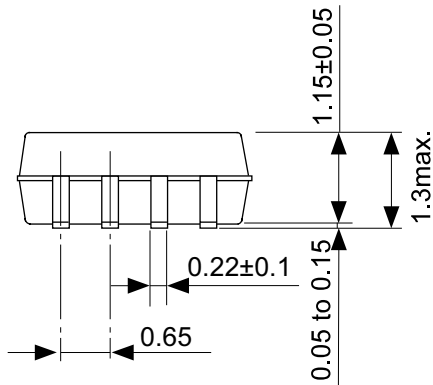
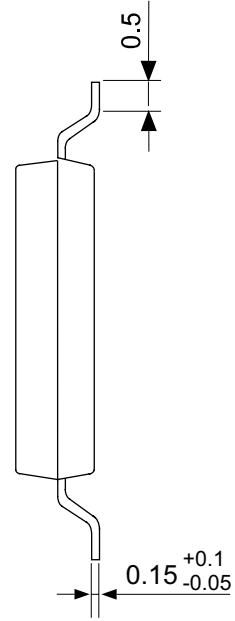
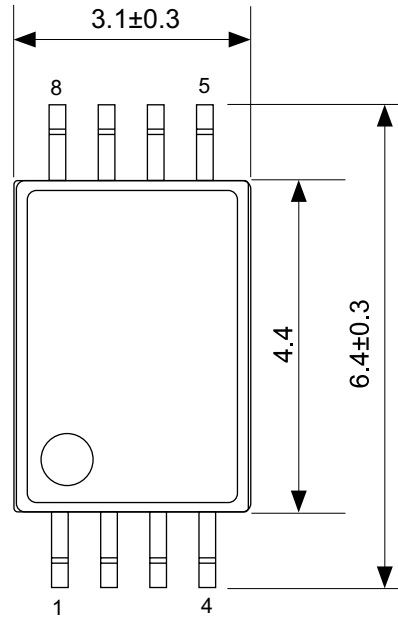

No. FS008-A-P-SD-1.1

TITLE	SSOP8-A-PKG Dimensions
No.	FS008-A-P-SD-1.1
SCALE	
UNIT	mm
Seiko Instruments Inc.	

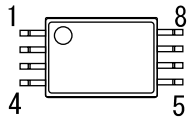
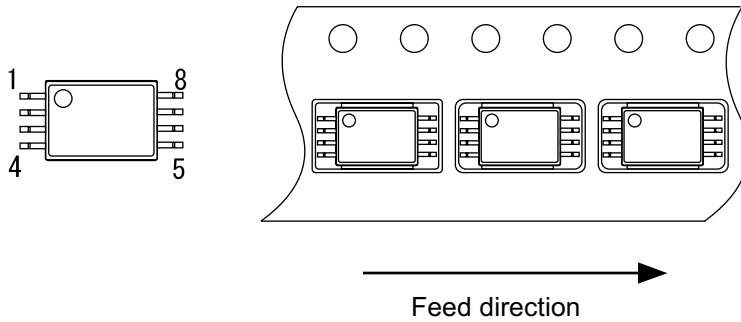
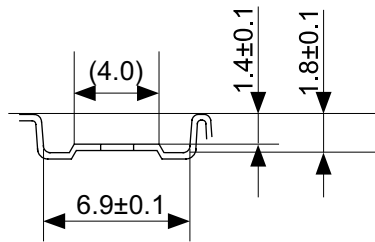
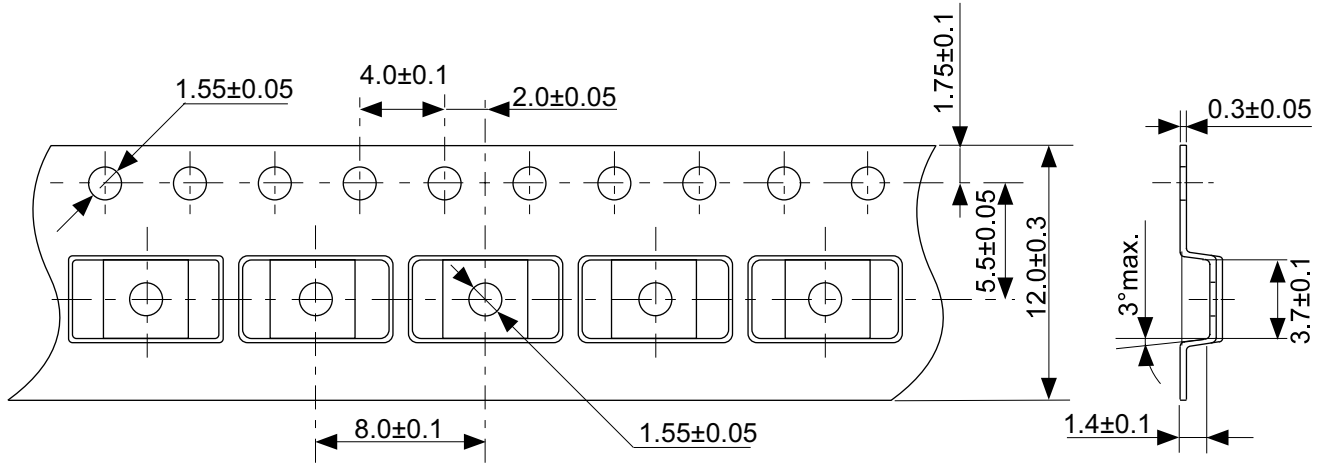

No. FS008-A-C-SD-1.1

TITLE	SSOP8-A-Carrier Tape
No.	FS008-A-C-SD-1.1
SCALE	
UNIT	mm
Seiko Instruments Inc.	

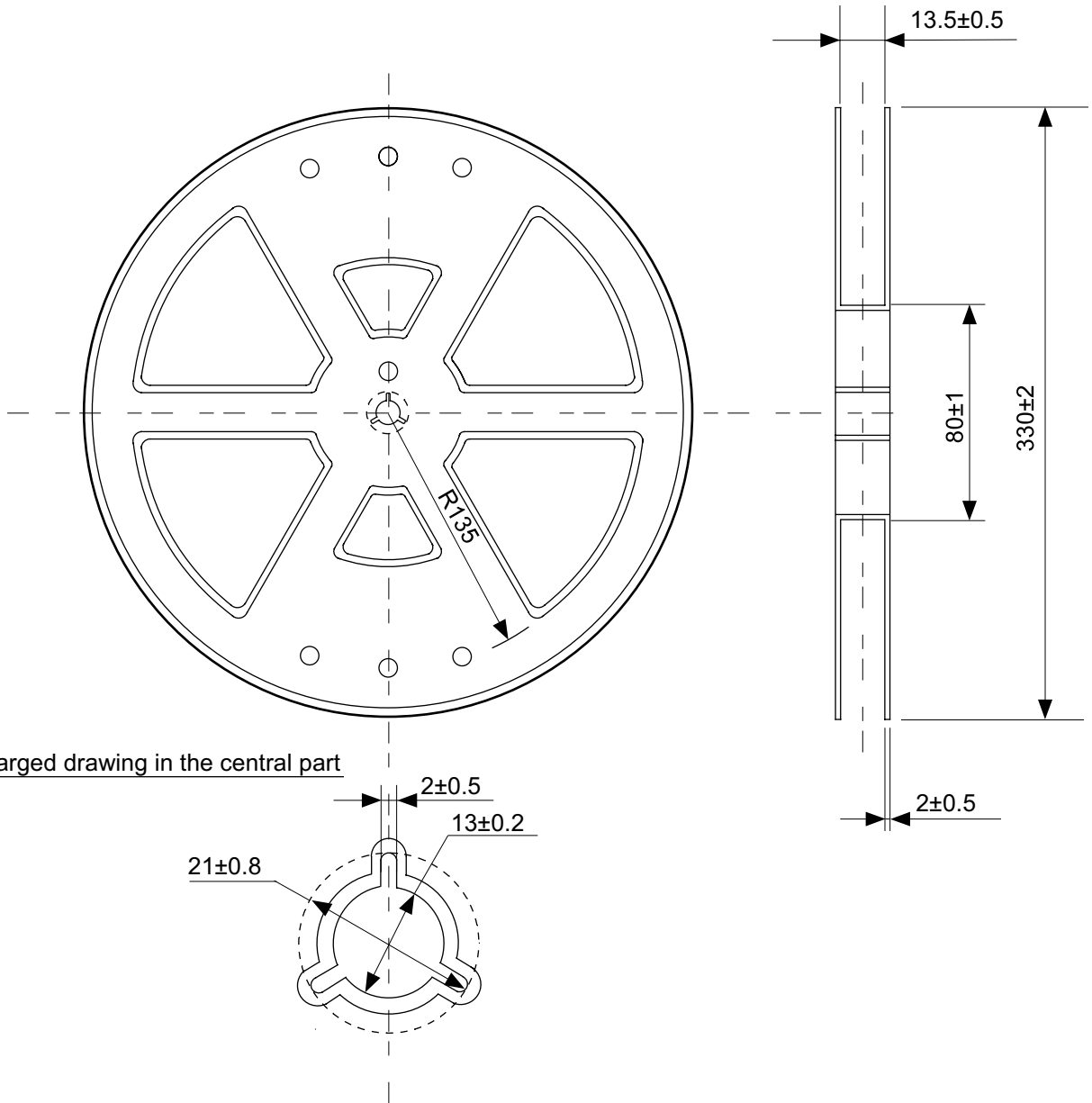

No. FS008-A-R-SD-1.1

TITLE	SSOP8-A-Reel		
No.	FS008-A-R-SD-1.1		
SCALE		QTY.	2,000
UNIT	mm		
Seiko Instruments Inc.			

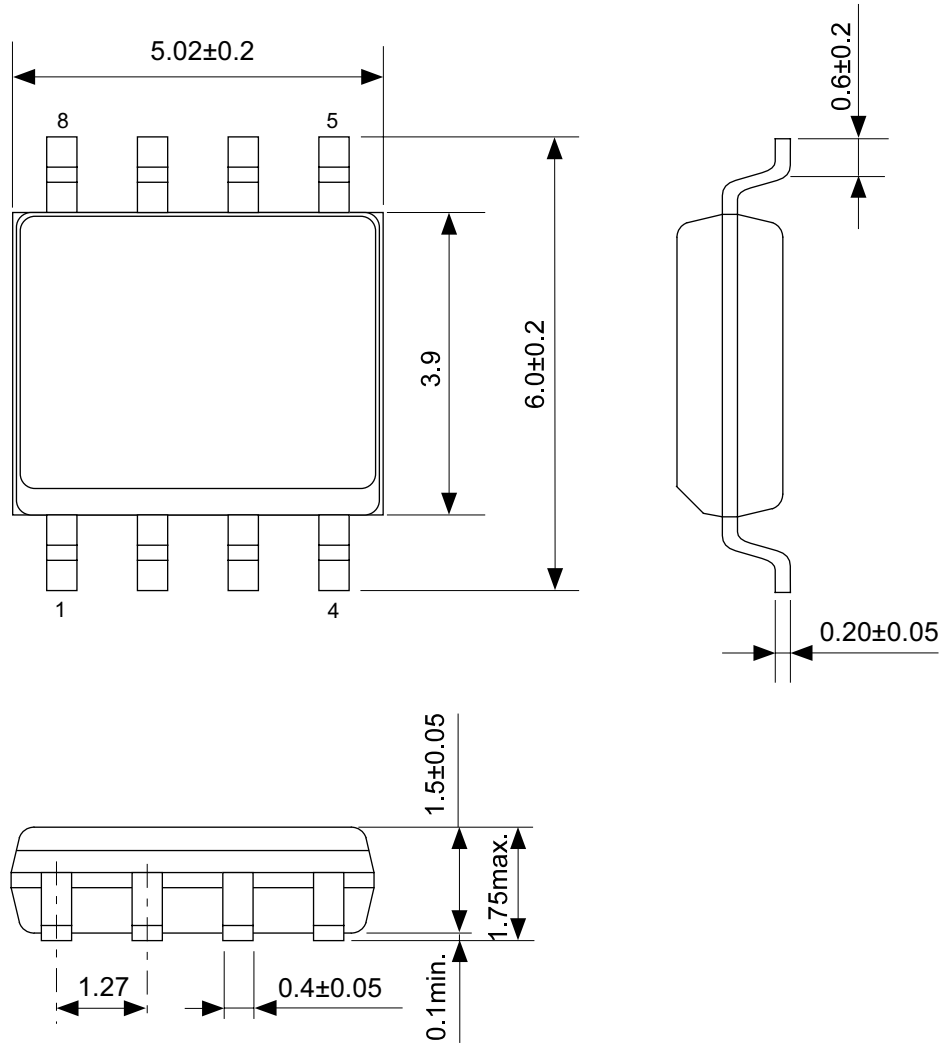

No. FJ008-A-P-SD-2.1

TITLE	SOP8J-A-PKG Dimensions
No.	FJ008-A-P-SD-2.1
SCALE	
UNIT	mm
Seiko Instruments Inc.	

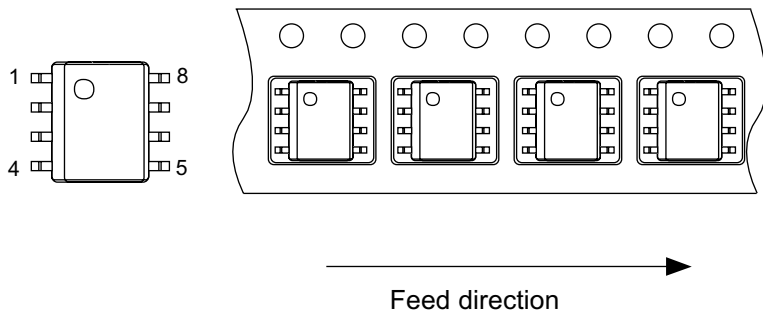
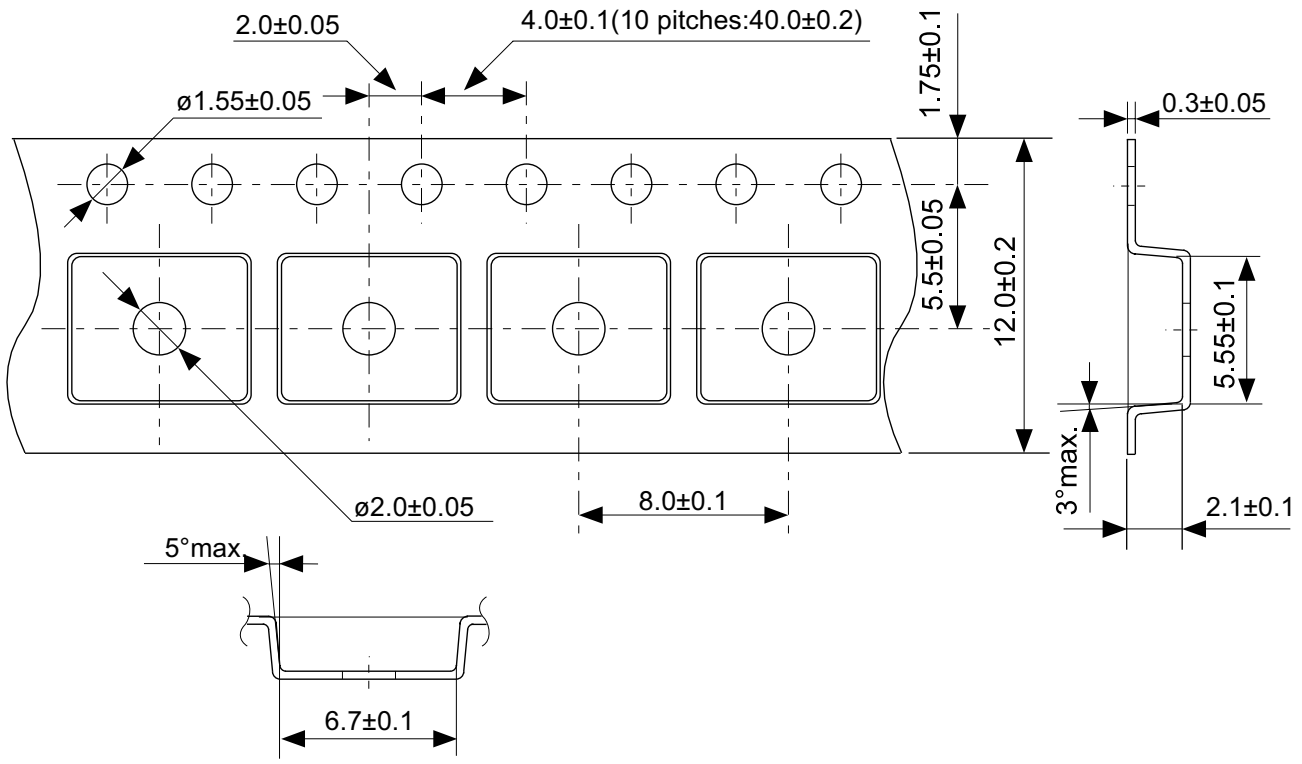

No. FJ008-D-C-SD-1.1

TITLE	SOP8J-D-Carrier Tape
No.	FJ008-D-C-SD-1.1
SCALE	
UNIT	mm
Seiko Instruments Inc.	

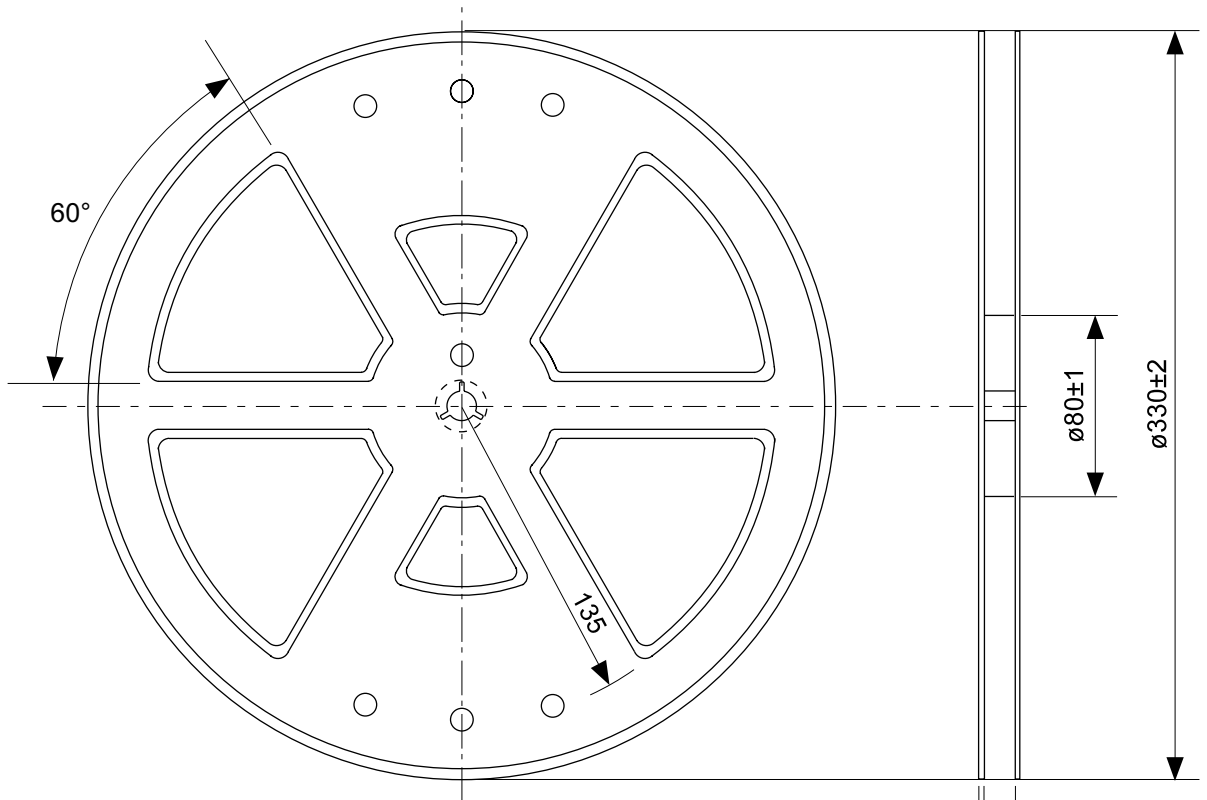

Enlarged drawing in the central part

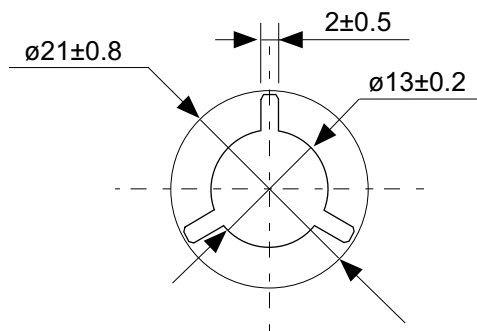

No. FJ008-D-R-SD-1.1

TITLE	SOP8J-D-Reel		
No.	FJ008-D-R-SD-1.1		
SCALE		QTY.	2,000
UNIT	mm		
Seiko Instruments Inc.			

- The information described herein is subject to change without notice.
- Seiko Instruments Inc. is not responsible for any problems caused by circuits or diagrams described herein whose related industrial properties, patents, or other rights belong to third parties. The application circuit examples explain typical applications of the products, and do not guarantee the success of any specific mass-production design.
- When the products described herein are regulated products subject to the Wassenaar Arrangement or other agreements, they may not be exported without authorization from the appropriate governmental authority.
- Use of the information described herein for other purposes and/or reproduction or copying without the express permission of Seiko Instruments Inc. is strictly prohibited.
- The products described herein cannot be used as part of any device or equipment affecting the human body, such as exercise equipment, medical equipment, security systems, gas equipment, or any apparatus installed in airplanes and other vehicles, without prior written permission of Seiko Instruments Inc.
- Although Seiko Instruments Inc. exerts the greatest possible effort to ensure high quality and reliability, the failure or malfunction of semiconductor products may occur. The user of these products should therefore give thorough consideration to safety design, including redundancy, fire-prevention measures, and malfunction prevention, to prevent any accidents, fires, or community damage that may ensue.