

Contents

Features	1
Applications	1
Functions.....	1
Block Diagram	1
Terminals.....	2
Absolute Maximum Ratings (Ta=25 °C).....	3
Recommended Operating Conditions.....	3
Electrical Characteristics (Ta=25 °C, VDD=3.0 V) ...	4
Electrical Characteristic Curves	4

The S-8270A is a CMOS IC developed for infrared remote control System. A photodetecting PIN diode can be directly connected. An input amplifier, limiter amplifier, band-pass filter, detector and an output waveform shaper are contained in a one-chip.

■ Features

Characteristics

- Power supply voltage : 2.4 to 6.0 V ($I_{IN}=30\ \mu\text{A}$)
- Current consumption: 0.13 mA typ. 0.25 mA max. at 3.0 V

Hardware functions

- Incorporates band-pass filter
(possible to adjust resonance frequency by external resistance: $f_0=30$ to 46KHz)
- Incorporates trap filter
Possible to connect input terminal directly to photodetecting PIN diode
- Output logic is active "LOW"
- Output is generated N-channel open drain with pull-up resistor (Possible to connect output terminal directly to TTL or CMOS)

Package

- 8-pin SOP: S-8270AFE
- 8-pin DIP : S-8270ADP

■ Applications

- Infrared remote control encoder for TVs, VCRs, audio devices
- Infrared remote control TOYS

■ Functions

The S-8270A amplifies the voltage converted from the current signal of the PIN diode, which is coupled directly to S-8270A, at the reception of the infrared.

The signal, then, goes through the band-pass filter for noise reduction before being input to the discriminator. The discriminator recovers the transmitted data out of a burst signal. Finally the data are shaped by the signal shaping circuit.

■ Block diagram

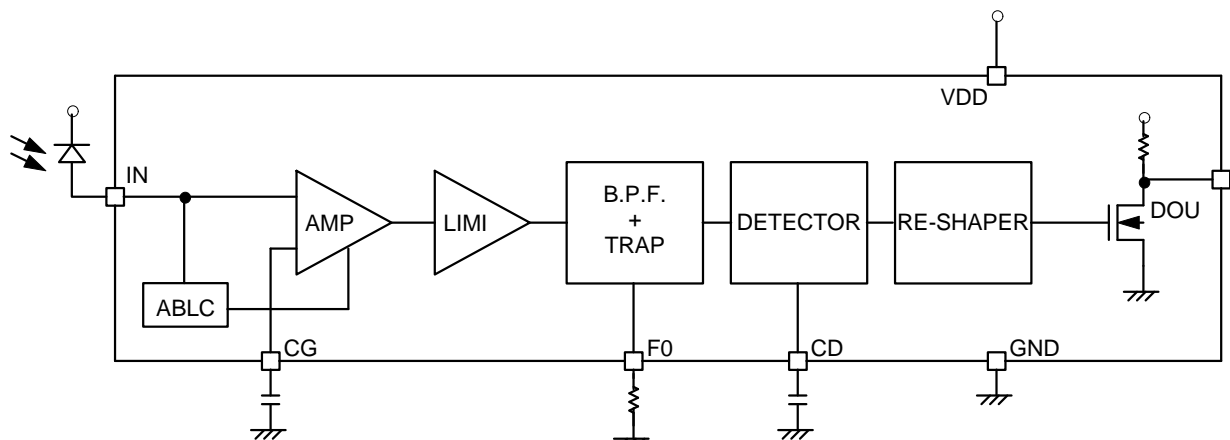

Figure 1

RECEIVER IC FOR INFRARED REMOTE CONTROLLER S-8270A

■ Terminals

1.Pin assignment (Top view)

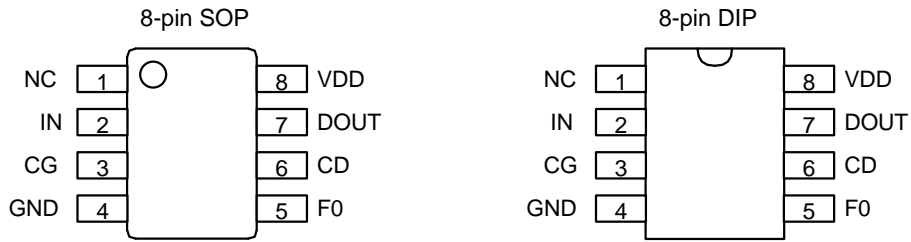
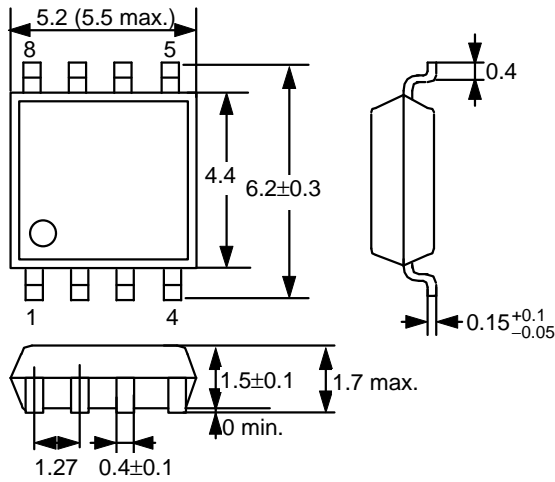

Figure 2

2.Dimensions

8-Pin SOP



Unit : mm

Figure 3

8-Pin DIP

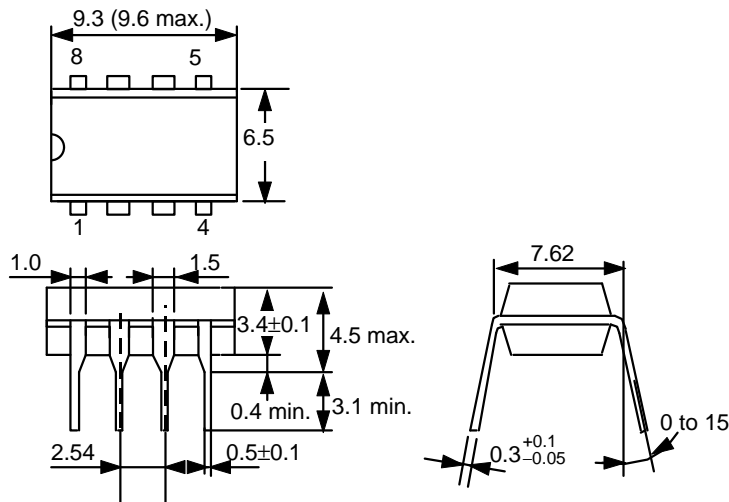

Unit : mm

Figure 4

3. Terminal Description

Table 1

Terminal No.	Symbol	External parts	Description
1	NC		<ul style="list-style-type: none"> No connection
2	IN	Photodetecting PIN diode	<ul style="list-style-type: none"> Input terminal which connects photodetecting PIN diode. Internal impedance is 50 kΩ typ. Therefore a photodetecting PIN diode can be directly connected. ABL (Automatic Bias Level Control) prevent from saturation of input level
3	CG	1500pF to 0.01μF	<ul style="list-style-type: none"> Input terminal which connects condenser to AMP gain control.
4	VSS		<ul style="list-style-type: none"> •E GND potential terminal.
5	F0	24K Ω	<ul style="list-style-type: none"> Input terminal which connects resistance to adjust resonance frequency of band-pass filter (f0=30 to 46KHZ) TRAP AMP. prevent from illegal action which is caused by high frequency noise of fluorescent lamp.
6	CD	200pF	<ul style="list-style-type: none"> Input terminal which connects condenser to adjust detector circuit.
7	DOUT		<ul style="list-style-type: none"> Output terminal which output logic is active "LOW". Output is generated at N-channel open drain with pull-up resistor, which is easily interfaced to next stage circuit.
8	VDD		<ul style="list-style-type: none"> Positive power supply

■ Absolute Maximum Ratings (Ta=25 °C)

Table 2

Item	Symbol	Rating	Unit
Storage temperature	Tstg	-40 to +125	C
Operating ambient temperature	Topr	-30 to +85	C
Power supply voltage	V _{DD}	-0.3 to +7.0	V
Input voltage	V _{IN}	0 to V _{DD}	V
Output voltage	V _{OUT}	0 to V _{DD}	V
Power dissipation	Pd	200	mW

■ Recommended Operating Conditions

Table 3

Item	Symbol	Conditions	Min.	Typ.	Max.	Unit
Power supply voltage	V _{DD}	I _{IN} =30 μA	2.4		6.0	V
		I _{IN} =300 μA	2.7		6.0	V
Input frequency	f _{in}		30		46	KHz
Condenser for AMP gain control	CG			2000		pF
Resistor to adjust resonance frequency of band-pass filter	F0	f _{IN} =38 KHz		24		KΩ
Condenser to adjust detector circuit	CD			200		pF

RECEIVER IC FOR INFRARED REMOTE CONTROLLER S-8270A

■ Electrical Characteristics (Ta=25 °C, V_{DD}=3.0 V)

Table 4

Item	Symbol	Conditions	Min.	Typ.	Max.	Unit
Operating current consumption	I _{DD}	V _{IN} =V _{SS}	—	0.13	0.25	mA
AMP gain	AV	f _{in} =38 KHz V _{IN} =30 μVp-p (*1)	77	80	83	dB
Resonance frequency of band-pass filter	f ₀	V _{IN} =300 μVp-p (*1)	—	38	—	KHz
Band width of band-pass filter	f _{BW}	-3dB band width f ₀ =38 KHz	2.0	2.5	3.0	KHz
Output pulse width	tpw	f _{in} =38 KHz BW V _{IN} =50 mVp-p (*2)	440	—	770	μS
Low level output voltage	V _{OL}	I _{OL} =0.1 mA	—	—	0.4	V
High level output current	I _{OH}	V _{OH} =V _{DD}	-1	—	1	μA
Input resistance	R _{IN}	I _{IN} =300 μA (*3)	30	50	70	KΩ
Input voltage 1	V _{IN1}	I _{IN} =0 μA	—	0	—	V
Input voltage 2	V _{IN2}	I _{IN} =300 μA	0.5	1.2	1.8	V
Output pull-up resistance	R _{OUT}	V _{DD} =3.0V	50	100	200	KΩ

(*1) V_{IN} is input voltage

(*2) Input (burst wave)

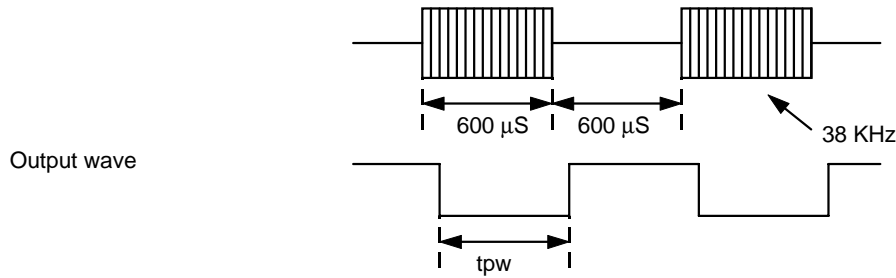

(*3) V_{IN} : Input voltage, Vr : Measurement voltage

$$R_{IN} = \frac{50}{V_{IN}/V_r - 1} \text{ [K}\Omega\text{]}$$

■ Electrical Characteristic Curves

(1) Voltage Gain - Frequency

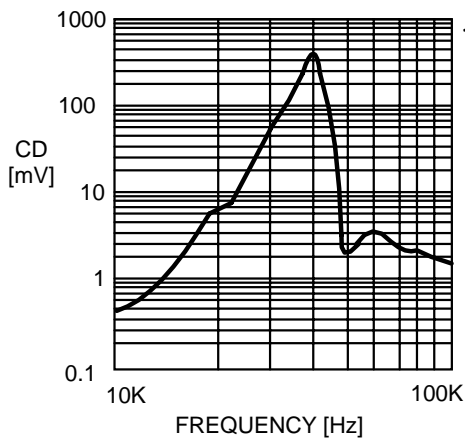

<CONDITIONS>
f_{IN}=38 KHz
V_{IN}=100 μVp-p
V_{DD}=3.0 V
Ta=25 °C

(2) AMP Gain - External Condenser

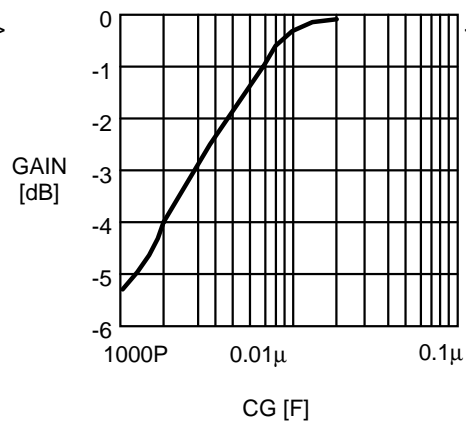

<CONDITIONS>
V_{DD}=3.0 V
Ta=25 °C

(3) Input - Output

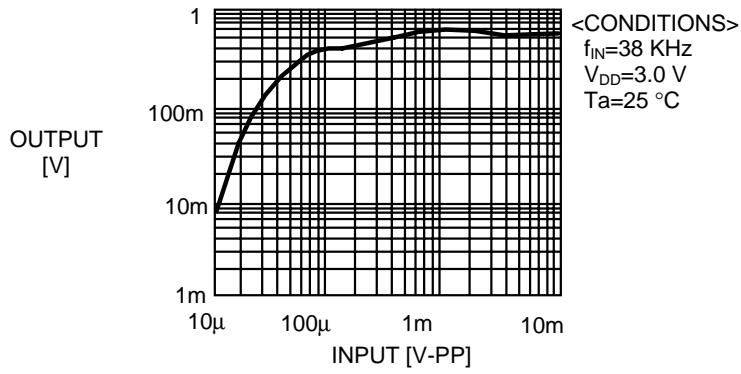

(4) V_{DD} - Operating current

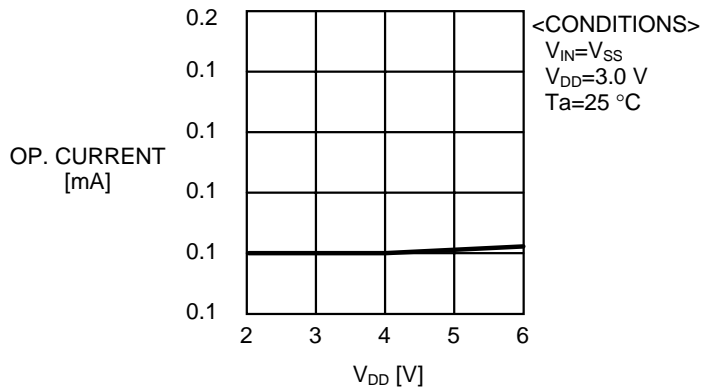

(5) B.P.F frequency - External Resistor

