

Rochester Electronics Manufactured Components

Rochester branded components are manufactured using either die/wafers purchased from the original suppliers or Rochester wafers recreated from the original IP. All recreations are done with the approval of the OCM.

Parts are tested using original factory test programs or Rochester developed test solutions to guarantee product meets or exceed the OCM data sheet.

Quality Overview

- ISO-9001
- AS9120 certification
- Qualified Manufacturers List (QML) MIL-PRF-35835
 - Class Q Military
 - Class V Space Level
- Qualified Suppliers List of Distributors (QSLD)
 - Rochester is a critical supplier to DLA and meets all industry and DLA standards.

Rochester Electronics, LLC is committed to supplying products that satisfy customer expectations for quality and are equal to those originally supplied by industry manufacturers.

The original manufacturer's datasheet accompanying this document reflects the performance and specifications of the Rochester manufactured version of this device. Rochester Electronics guarantees the performance of its semiconductor products to the original OEM specifications. 'Typical' values are for reference purposes only. Certain minimum or maximum ratings may be based on product characterization, design, simulation, or sample testing.



Low Cost IC Multiplier, Divider, Squarer, Square Rooter

AD533

FEATURES

- Simplicity of Operation: Only Four External Adjustments
- Max 4-Quadrant Error Below 0.5% (AD533L)
- Low Temperature Drift: 0.01%/°C (AD533L)
- Multiplies, Divides, Squares, Square Roots

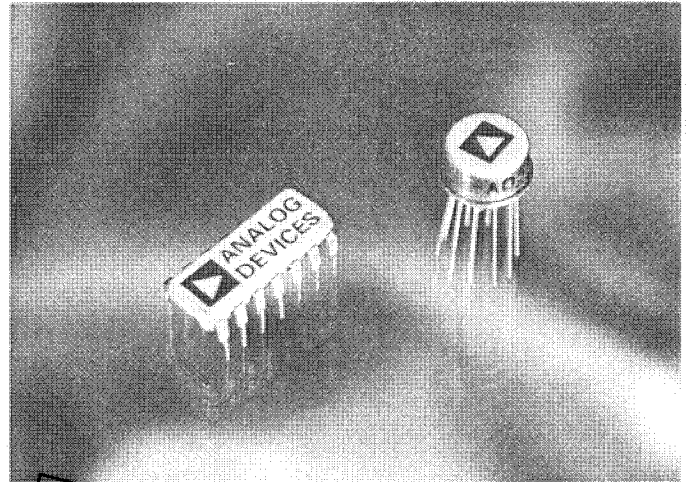

OBSOLETE

PRODUCT DESCRIPTION

The Analog Devices AD533 is a low cost integrated circuit multiplier comprised of a transconductance multiplying element, stable reference, and output amplifier on a monolithic silicon chip. Specified accuracy is easily achieved by the straight-forward adjustment of feedthrough, output zero, and gain trim pots. The AD533 multiplies in four quadrants with a transfer function of $XY/10V$, divides in two quadrants with a $10VZ/X$ transfer function, and square roots in one quadrant with a transfer function of $-\sqrt{10VZ}$. Several levels of accuracy are provided: the AD533J, AD533K, and AD533L, for 0 to +70°C operation, are specified for maximum multiplying errors of 2%, 1%, and 0.5% respectively at +25°C. The AD533S, for operation from -55°C to +125°C, is guaranteed for a maximum 1% multiplying error at +25°C. The maximum error specification is a true measure of overall accuracy since it includes the effects of offset voltage, feedthrough, scale factor, and nonlinearity in all four quadrants.

The low drift design of the AD533 insures that high accuracy is maintained with variations in temperature. The op amp output provides ±10 volts at 5mA, and is fully protected against short circuits to ground or either supply voltage: all inputs are fully protected against over-voltage transients with internal series resistors. The devices provide excellent ac performance, with typical small signal bandwidth of 1.0MHz, full power bandwidth of 750kHz, and slew rate of 45V/μs.

The low cost and simplicity of operation of the AD533 make it especially well suited for use in such widespread applications as modulation and demodulation, automatic gain control and phase detection. Other applications include frequency discrimination, rms computation, peak detection, voltage controlled oscillators and filters, function generation, and power measurements.

All models are available in the hermetically sealed TO-18 metal can and TO-116 ceramic DIP packages.

Information furnished by Analog Devices is believed to be accurate and reliable. However, no responsibility is assumed by Analog Devices for its use; nor for any infringements of patents or other rights of third parties which may result from its use. No license is granted by implication or otherwise under any patent or patent rights of Analog Devices.

One Technology Way, P.O. Box 9106, Norwood, MA 02062-9106, U.S.A.
 Tel: 617/329-4700 Fax: 617/326-8703 Twx: 710/394-6577
 Telex: 924491 Cable: ANALOG NORWOODMASS

SPECIFICATIONS (typical @ +25°C, externally trimmed and $V_S = \pm 15V$ dc unless otherwise specified)

PARAMETER	CONDITIONS	AD533J	AD533K	AD533L	AD533S
ABSOLUTE MAX RATINGS					
Internal Power Dissipation		500mW	*	*	*
Input Voltage ¹			*	*	*
$X_{in}, Y_{in}, Z_{in}, X_o, Y_o, Z_o$		$\pm V_S$	*	*	*
Rated Operating Temp Range		0 to +70°C	*	*	-55°C to +125°C
Storage Temp Range		-65°C to +150°C	*	*	*
Output Short Circuit	To Ground	Indefinite	*	*	*
MULTIPLIER SPECIFICATIONS					
Transfer Function		XY/10V	*	*	*
	Untrimmed	XY/6V max [XY/10V min]	*	*	*
Total Error (of full scale)		$\pm 2.0\%$ max	$\pm 1.0\%$ max	$\pm 0.5\%$ max	$\pm 1.0\%$ max
	$T_A = \text{min to max}$	$\pm 3.0\%$	$\pm 2.0\%$	$\pm 1.0\%$	$\pm 1.5\%$
vs. Temperature	$T_A = \text{min to max}$	$\pm 0.04\%/^{\circ}\text{C}$	$\pm 0.03\%/^{\circ}\text{C}$	$\pm 0.01\%/^{\circ}\text{C}$	$\pm 0.01\%/^{\circ}\text{C}$
Nonlinearity				**	**
X Input	$V_X = V_O = 20V$ (p-p)	$\pm 0.8\%$	$\pm 0.5\%$	**	**
Y Input	$V_Y = V_O = 20V$ (p-p)	$\pm 0.3\%$	$\pm 0.2\%$	**	**
Feedthrough					
X Input	$V_X = 20V$ (p-p), $V_Y = 0$, $f = 50\text{Hz}$	200mV (p-p) max	150mV (p-p) max	50mV (p-p) max	100mV (p-p) max
Y Input	$V_Y = 20V$ (p-p), $V_X = 0$, $f = 50\text{Hz}$	200mV (p-p) max	150mV (p-p) max	50mV (p-p) max	100mV (p-p) max
DIVIDER SPECIFICATIONS					
Transfer Function		10V/Z/X	*	*	*
	Untrimmed	10V/Z/X max [6V/Z/X min]	*	*	*
Total Error (of full scale)		$\pm 1.0\%$	$\pm 0.5\%$	$\pm 0.2\%$	$\pm 0.5\%$
	$V_Z = \pm 10V$ dc, $V_X = \pm 10V$ dc	$\pm 3.0\%$	$\pm 2.0\%$	$\pm 1.5\%$	$\pm 2.0\%$
	$V_X = \pm 1V$ dc, $V_Z = \pm 10V$ dc				
SQUARER SPECIFICATIONS					
Transfer Function		$X^2/10V$	*	*	*
	Untrimmed	$X^2/6V$ max [$X^2/10V$ min]	*	*	*
Total Error (of full scale)		$\pm 0.8\%$	$\pm 0.4\%$	$\pm 0.2\%$	$\pm 0.4\%$
SQUARE ROOTER SPECIFICATIONS					
Transfer Function		$\sqrt{10VZ}$	*	*	*
	Untrimmed	$-\sqrt{10VZ}$ max [$\sqrt{6VZ}$ min]	*	*	*
Total Error (of full scale)		$\pm 0.8\%$	$\pm 0.4\%$	$\pm 0.2\%$	$\pm 0.4\%$
INPUT SPECIFICATIONS					
Input Resistance					
X Input		10M Ω	*	*	*
Y Input		6M Ω	*	*	*
Z Input		36k Ω	*	*	*
Input Bias Current					
X, Y Inputs		3 μA	7.5 μA max	5 μA max	7.5 μA max
Z Input		$\pm 25\mu\text{A}$	*	*	*
X, Y Inputs	$T_A = \text{min to max}$	12 μA	10 μA	7 μA	7 μA
Z Input	$T_A = \text{min to max}$	$\pm 35\mu\text{A}$	*	*	*
Input Voltage					
V_X, V_Y, V_Z	For Rated Accuracy	$\pm 10V$	*	*	*
DYNAMIC SPECIFICATIONS					
Small Signal, Unity Gain		1.0MHz	*	*	*
Full Power Bandwidth		750kHz	*	*	*
Slew Rate		45V/ μs	*	*	*
Small Signal Amplitude Error		1% at 75kHz	*	*	*
Sm Sig 1% Vector Error	0.5° phase shift	5kHz	*	*	*
Settling Time	$\pm 10V$ step	1 μs to 2%	*	*	*
Overload Recovery		2 μs to 2%	*	*	*
OUTPUT AMPLIFIER SPECIFICATIONS					
Output Impedance		1 Ω	*	*	*
Output Voltage Swing	$T_A = \text{min to max}$ $R_L \geq 2k\Omega, C_L \leq 1000\text{pF}$	$\pm 10V$ min	*	*	*
Output Noise	$f = 5\text{Hz to } 10\text{kHz}$ $f = 5\text{Hz to } 5\text{MHz}$	0.6mV (rms) 3.0mV (rms)	*	*	*
Output Offset Voltage		Trimable To Zero	*	*	*
vs. Temperature	$T_A = \text{min to max}$	0.7mV/ $^{\circ}\text{C}$	*	*	*
POWER SUPPLY SPECIFICATIONS					
Supply Voltage	Rated Performance	$\pm 15V$	*	*	*
	Operating	$\pm 15V$ to $\pm 18V$	$\pm 10V$ to $\pm 18V$	$\pm 10V$ to $\pm 18V$	$\pm 10V$ to $\pm 22V$
Supply Current	Quiescent	$\pm 6\text{mA}$ max	*	*	*
Power Supply Variation	Includes Effects of Recommended Null Pots				
Multiplier Accuracy		$\pm 0.5\%/%$	*	*	*
Output Offset		$\pm 10\text{mV}/%$	*	*	*
Scale Factor		$\pm 0.1\%/%$	*	*	*
Feedthrough		$\pm 10\text{mV}/%$	*	*	*

NOTES

¹Max input voltage is zero when supplies are turned off.

*Specifications same as AD533J.

**Specifications same as AD533K.

Specifications subject to change without notice.

MULTIPLIER

Multiplier operation is accomplished by closing the loop around the internal op amp with the Z input connected to the output. The X_0 null pot balances the X input channel to minimize Y feedthrough and similarly the Y_0 pot minimizes the X feedthrough. The Z_0 pot nulls the output op amp offset voltage and the gain pot sets the full scale output level.

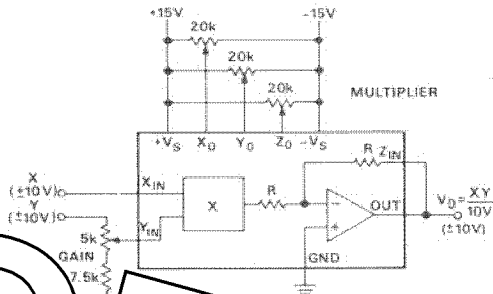

TRIM PROCEDURES

1. With $X = Y = 0$ volts, adjust Z_0 for 0V dc output.
2. With $Y = 20$ volts p-p (at $f = 50$ Hz) and $X = 0$ V, adjust X_0 for minimum ac output.
3. With $X = 20$ volts p-p (at $f = 50$ Hz) and $Y = 0$ V, adjust Y_0 for minimum ac output.
4. Readjust Z_0 for 0V dc output.
5. With $X = +10$ V dc and $Y = 20$ volts p-p (at $f = 50$ Hz), adjust gain for output = Y_{in} .

NOTE: For best accuracy over limited voltage ranges (e.g., ± 5 V), gain and feedthrough adjustments should be optimized with the inputs in the desired range, as linearity is considerably better over smaller ranges of input.

SQUARER

Squarer operation is a special case of multiplier operation where the X and Y inputs are connected together and two quadrant operation results since the output is always positive. When the X and Y inputs are connected together, a composite offset results which is the algebraic sum of the individual offsets which can be nulled using the X_0 pot alone.

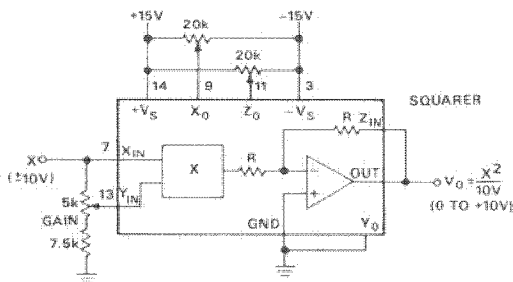

TRIM PROCEDURES

1. With $X = 0$ volts, adjust Z_0 for 0V dc output.
2. With $X = +10$ V dc, adjust gain for +10V dc output.
3. Reverse polarity of X input and adjust X_0 to reduce the output error to $\frac{1}{2}$ its original value, readjust the gain to take out the remaining error.
4. Check the output offset with input grounded. If nonzero, repeat the above procedure until no errors remain.

DIVIDER

The divide mode utilizes the multiplier in a fed-back configuration where the Y input now controls the feedback factor. With $X =$ full scale, the gain (V_O/Z) becomes unity after trimming. Reducing the X input reduces the feedback around the op amp by a like amount, thereby increasing the gain. This reciprocal relationship forms the basis of the divide mode. Accuracy and bandwidth decrease as the denominator decreases.

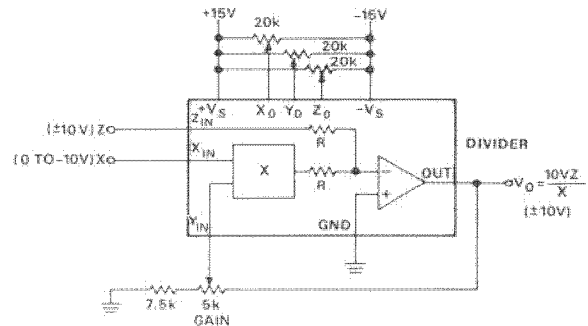

TRIM PROCEDURES

1. Set all pots at mid-scale.
2. With $Z = 0$ V, trim Z_0 to hold the output constant, as X is varied from -10V dc through -1V dc.
3. With $Z = 0$ V, $X = -10$ V dc, trim Y_0 for 0V dc.
4. With $Z = X$ or $-X$, trim X_0 for the minimum worst-case variations as X is varied from -10V dc to -1V dc.
5. Repeat steps 2 and 3 if step 4 requires a large initial adjustment.
6. With $Z = X$ or $-X$, trim the gain for the closest average approach to ± 10 V dc output as X is varied from -10V dc to -3V dc.

SQUARE ROOTER

This mode is also a fed-back configuration with both the X and Y inputs tied to the op amp output through an external diode to prevent latchup. Accuracy, noise and frequency response are proportional to \sqrt{Z} , which implies a wider usable dynamic range than the divide mode.

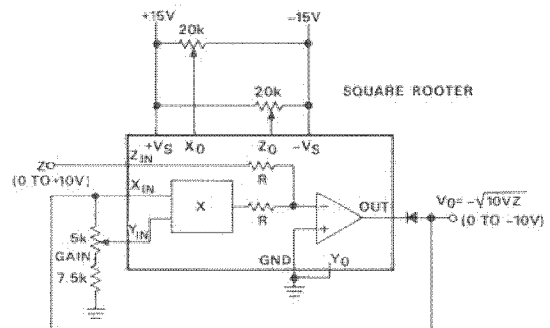

TRIM PROCEDURES

1. With $Z = +0.1$ V dc, adjust Z_0 for Output = -1.0V dc.
2. With $Z = +10.0$ V dc, adjust gain for Output = -10.0V dc.
3. With $Z = +2.0$ V dc, adjust X_0 for Output = -4.47 ± 0.1 V dc.
4. Repeat steps 2 and 3, if necessary. Repeat step 1.

TYPICAL PERFORMANCE CHARACTERISTICS

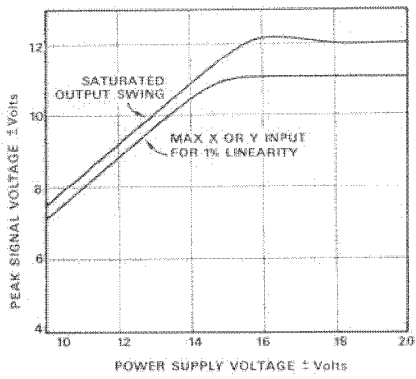

Allowable Signal Swing vs. Supply Voltage

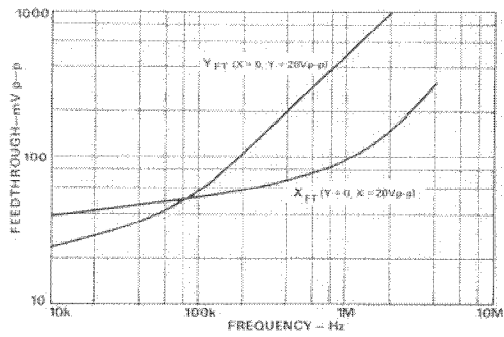

Feedthrough vs. Frequency

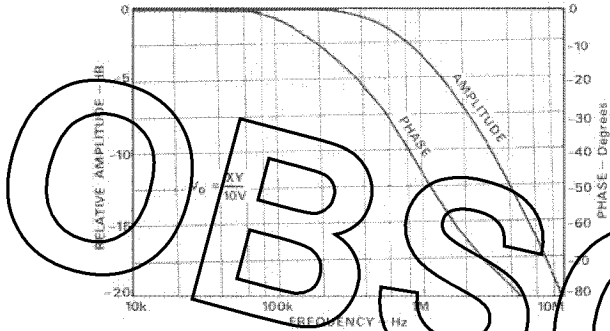

Closed Loop Frequency and Phase Response

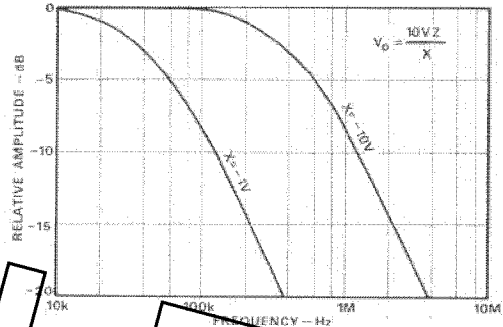

Divide Mode Frequency Response

PIN CONFIGURATION & DIMENSIONS

Dimensions shown in inches and (mm).

AD533H
TO-100

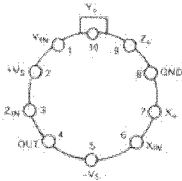

TOP VIEW

AD533D
TO-116

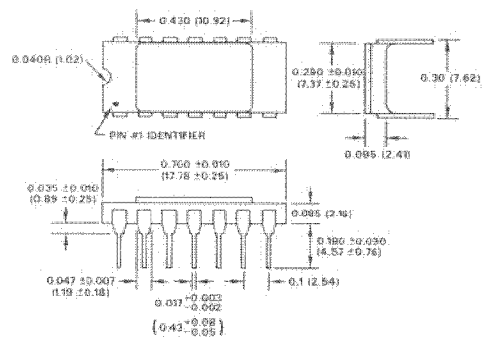
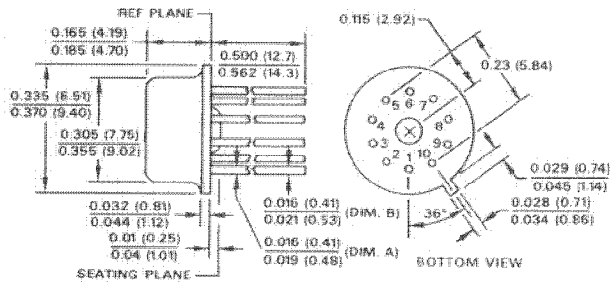
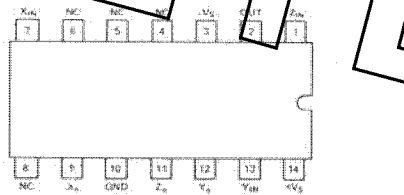

ORDERING GUIDE

MODEL	MULT. ERROR (Max @ +25°C)	TEMP. RANGE	ORDER NUMBER
AD533J	±2.0%	0 to +70°C	AD533JH* AD533JD†
AD533K	±1.0%	0 to +70°C	AD533KH AD533KD
AD533L	±0.5%	0 to +70°C	AD533LH AD533LD
AD533S	±1.0%	-55°C to +125°C	AD533SH AD533SD

*TO-100 metal can package

†TO-116 ceramic DIP package