

Standard Products

# UT699E 32-bit Fault-Tolerant SPARC™ V8/LEON 3FT Processor

Preliminary Data Sheet

March 12, 2014

[www.aeroflex.com/LEON](http://www.aeroflex.com/LEON)



## FEATURES

- ❑ Backward compatible with the UT699
- ❑ Supports up to 100MHz clock rate
- ❑ Separate instruction and data cache architecture
- ❑ High-performance pipelined IEEE-754 FPU
- ❑ Enhanced pipeline with 1.2 DMIPS / MHz performance
- ❑ Implemented on 130nm CMOS technology
- ❑ Internally configured clock network
- ❑ Power saving 1.2V core power supply
- ❑ 3.3V I/O compatibility
- ❑ On-board programmable timers and interrupt controllers
- ❑ SEU hardened-by-design flip-flops and memory cells
- ❑ 10/100 Base-T Ethernet port for VxWorks development
- ❑ Integrated PCI 2.2 compatible core
- ❑ Four integrated multi-protocol SpaceWire nodes that support the RMAP protocol
- ❑ Two CAN 2.0 compliant bus interfaces
- ❑ Multifunctional memory controller
- ❑ -55°C to +105°C temperature range
- ❑ Operational environment:
  - Intrinsic total-dose: 100 krad(Si)
  - SEL Immune >100 MeV-cm<sup>2</sup>/mg
- ❑ Packaging options:
  - 484-pin Ceramic Land Grid, Column Grid and Ball Grid Array packages
- ❑ Standard Microcircuit Drawing 5962-13237
  - QML Q, Q+, and V (Pending)
- ❑ Applications
  - Nuclear power plant controls
  - Critical transportation systems
  - High-altitude avionics
  - Medical electronics
  - X-Ray cargo scanning
  - Spaceborne computer
  - System controller boards
  - Avionics processing boards

## INTRODUCTION

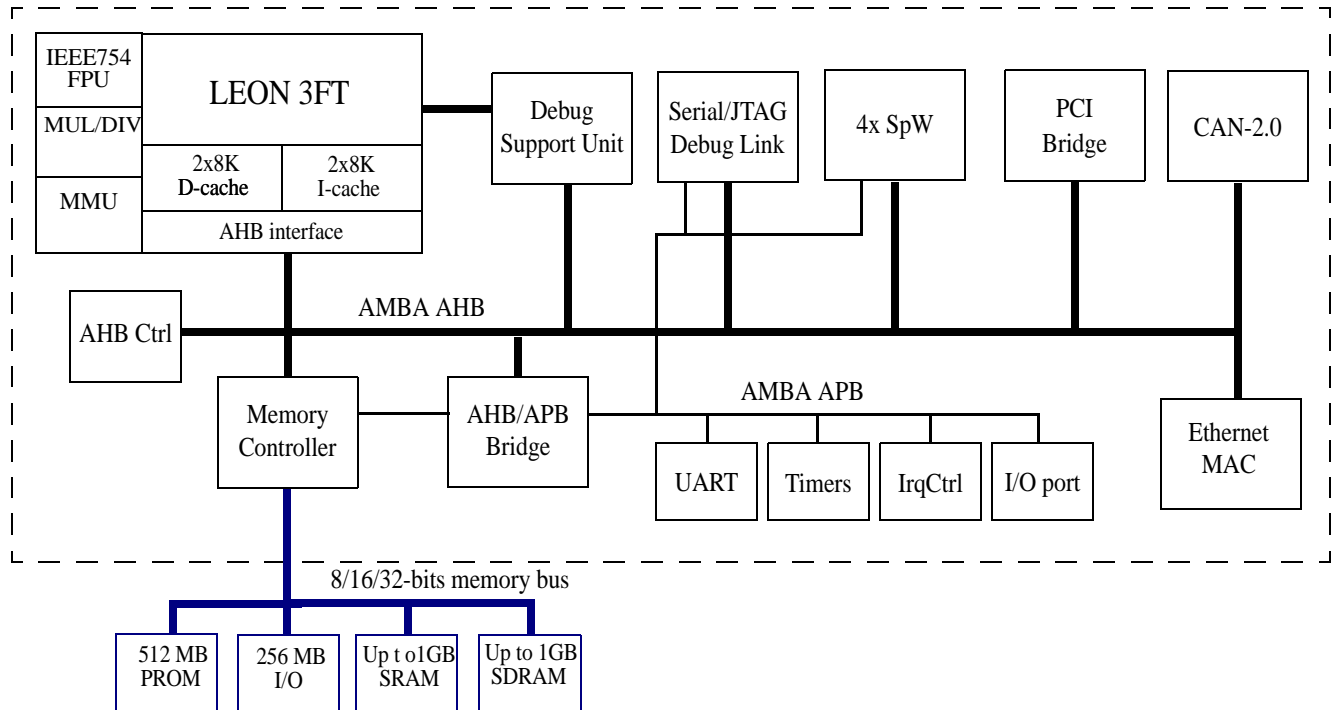
The UT699E is an enhanced version of the UT699 featuring a seven stage pipelined monolithic, high-performance, fault-tolerant SPARC™ V8/LEON 3FT Processor. L1 cache has been increased to 16kB for both instruction and data caches. Performance is increased to 1.2 DMIPS / MHz. RMAP protocol is supported for all four SpaceWire ports. Other enhancements include cache snooping. The UT699E provides a 32-bit master/target PCI interface, including a 16 bit user I/O interface for off-chip peripherals. A compliant 2.0 AMBA bus interface integrates the on-chip LEON 3FT, SpaceWire, Ethernet, memory controller, cPCI, CAN bus, and programmable interrupt peripherals.

The UT699E is SPARC V8 compliant; therefore, developers may use industry standard compilers, kernels, and development tools. A full software development suite is available including a C/C++ cross-compiler system based on GCC and the Newlib embedded C-library. Software developed for the UT699 will be 100% compatible with the UT699E.

BCC includes a small run-time kernel with interrupt support and Pthreads library. For multi-threaded applications, a SPARC™ compliant port of the eCos real-time kernel, RTEMS 4.10, and VxWorks 6.x is supported.

## 1.0 Introduction

The UT699E LEON 3FT processor is based upon the industry-standard SPARC V8 architecture. The system-on-chip incorporates the SPARC V8 core and the peripheral blocks indicated below. The core and peripherals communicate internally via the AMBA (Advanced Microcontroller Bus Architecture) interconnect. This bus is comprised of the AHB (Advanced High-speed Bus) which is used for high-speed data transfer, and the APB (Advanced Peripheral Bus) which is used for low-speed data transfer.



**Figure 1. UT699E Functional Block Diagram**

The LEON 3FT architecture includes the following peripheral blocks:

- LEON3 SPARC V8 integer unit with 16kB instruction cache and 16kB of data cache
- IEEE-754 floating point unit
- Debug support unit
- UART, JTAG, SpaceWire, and PCI debug links
- 8/16/32-bit memory controller with EDAC for external PROM and SRAM
- 32-bit SDRAM controller with EDAC for external SDRAM
- Timer unit with three 32-bit timers and watchdog
- Interrupt controller for 15 interrupts in two priority levels
- 16-bit general purpose I/O port (GPIO) which can be used as external interrupt sources
- Up to four SpaceWire links with RMAP on all channels
- Up to two CAN controllers
- Ethernet with support for MII
- cPCI interface with 8-channel arbiter

## 2.0 Pin Identification and Description

Pin Function	Description
I	CMOS input
IS	CMOS input Schmitt
O	CMOS output
I/O	CMOS bi-direct
OD	CMOS open drain
PCI-I	PCI input
PCI-O	PCI output
PCI-I/O	PCI bi-direct
PCI-3	PCI three-state

### 2.1. System Signals

Pin Name	Function	Pin Number	Reset Value	Description
		484 CLGA		
SYCLK	I	Y20	--	Main system clock
$\overline{\text{RESET}}$	IS	L19	--	System reset
$\overline{\text{ERROR}}^1$	OD	K19	--	Processor error mode indicator. This is an active low output.
$\overline{\text{WDOG}}^1$	OD	J19	--	Watchdog indicator. This is an active low output.

#### Notes:

1. This pin is actively driven low and must be tied to  $V_{DD}$  through a pull-up resistor.

### 2.2 Address Bus

Pin Name	Direction	Pin Number	Reset Value	Description
		484 CLGA		
ADDR[0]	O	W5	low	Bit 0 of the address bus
ADDR[1]	O	Y5	low	Bit 1 of the address bus
ADDR[2]	O	W6	low	Bit 2 of the address bus
ADDR[3]	O	AA5	low	Bit 3 of the address bus
ADDR[4]	O	Y6	low	Bit 4 of the address bus
ADDR[5]	O	AB5	low	Bit 5 of the address bus
ADDR[6]	O	W7	low	Bit 6 of the address bus
ADDR[7]	O	AA6	low	Bit 7 of the address bus
ADDR[8]	O	Y7	low	Bit 8 of the address bus

Pin Name	Direction	Pin Number	Reset Value	Description
		484 CLGA		
ADDR[9]	O	AA7	low	Bit 9 of the address bus
ADDR[10]	O	AB6	low	Bit 10 of the address bus
ADDR[11]	O	W8	low	Bit 11 of the address bus
ADDR[12]	O	AB7	low	Bit 12 of the address bus
ADDR[13]	O	Y8	low	Bit 13 of the address bus
ADDR[14]	O	AA8	low	Bit 14 of the address bus
ADDR[15]	O	W9	low	Bit 15 of the address bus
ADDR[16]	O	AB8	low	Bit 16 of the address bus
ADDR[17]	O	Y9	low	Bit 17 of the address bus
ADDR[18]	O	W10	low	Bit 18 of the address bus
ADDR[19]	O	AB9	low	Bit 19 of the address bus
ADDR[20]	O	Y10	low	Bit 20 of the address bus
ADDR[21]	O	AA9	low	Bit 21 of the address bus
ADDR[22]	O	W11	low	Bit 22 of the address bus
ADDR[23]	O	AA10	low	Bit 23 of the address bus
ADDR[24]	O	Y11	low	Bit 24 of the address bus
ADDR[25]	O	AB10	low	Bit 25 of the address bus
ADDR[26]	O	AB11	low	Bit 26 of the address bus
ADDR[27]	O	AA11	low	Bit 27 of the address bus

### 2.3 Data Bus

Pin Name	Direction	Pin Number	Reset Value	Description
		484 CLGA		
DATA[0]	I/O	W12	high-z	Bit 0 of the data bus
DATA[1]	I/O	W13	high-z	Bit 1 of the data bus
DATA[2]	I/O	Y12	high-z	Bit 2 of the data bus
DATA[3]	I/O	AA13	high-z	Bit 3 of the data bus
DATA[4]	I/O	AA12	high-z	Bit 4 of the data bus

Pin Name	Direction	Pin Number	Reset Value	Description
		484 CLGA		
DATA[5]	I/O	AB13	high-z	Bit 5 of the data bus
DATA[6]	I/O	W14	high-z	Bit 6 of the data bus
DATA[7]	I/O	AA14	high-z	Bit 7 of the data bus
DATA[8]	I/O	Y13	high-z	Bit 8 of the data bus
DATA[9]	I/O	W15	high-z	Bit 9 of the data bus
DATA[10]	I/O	AB15	high-z	Bit 10 of the data bus
DATA[11]	I/O	Y14	high-z	Bit 11 of the data bus
DATA[12]	I/O	AB14	high-z	Bit 12 of the data bus
DATA[13]	I/O	W16	high-z	Bit 13 of the data bus
DATA[14]	I/O	AA18	high-z	Bit 14 of the data bus
DATA[15]	I/O	Y15	high-z	Bit 15 of the data bus
DATA[16]	I/O	AB16	high-z	Bit 16 of the data bus
DATA[17]	I/O	AA15	high-z	Bit 17 of the data bus
DATA[18]	I/O	AB17	high-z	Bit 18 of the data bus
DATA[19]	I/O	AA16	high-z	Bit 19 of the data bus
DATA[20]	I/O	AA19	high-z	Bit 20 of the data bus
DATA[21]	I/O	W17	high-z	Bit 21 of the data bus
DATA[22]	I/O	AB18	high-z	Bit 22 of the data bus
DATA[23]	I/O	Y16	high-z	Bit 23 of the data bus
DATA[24]	I/O	Y17	high-z	Bit 24 of the data bus
DATA[25]	I/O	AA17	high-z	Bit 25 of the data bus
DATA[26]	I/O	W18	high-z	Bit 26 of the data bus
DATA[27]	I/O	AB19	high-z	Bit 27 of the data bus
DATA[28]	I/O	Y19	high-z	Bit 28 of the data bus
DATA[29]	I/O	AB20	high-z	Bit 29 of the data bus
DATA[30]	I/O	Y18	high-z	Bit 30 of the data bus
DATA[31]	I/O	AA20	high-z	Bit 31 of the data bus

## 2.4 Check Bits

Pin Name	Direction	Pin Number	Reset Value	Description
		484 CLGA		
CB[0]	I/O	V19	high-z	Bit 0 of EDAC checkbits
CB[1]	I/O	AA21	high-z	Bit 1 of EDAC checkbits
CB[2]	I/O	Y21	high-z	Bit 2 of EDAC checkbits
CB[3]	I/O	W19	high-z	Bit 3 of EDAC checkbits
CB[4]	I/O	Y22	high-z	Bit 4 of EDAC checkbits
CB[5]	I/O	W20	high-z	Bit 5 of EDAC checkbits
CB[6]	I/O	W22	high-z	Bit 6 of EDAC checkbits
CB[7]	I/O	W21	high-z	Bit 7 of EDAC checkbits

## 2.5 Memory Control Signals

Pin Name	Direction	Pin Number	Reset Value	Description
		484 CLGA		
$\overline{\text{WRITE}}$	O	V21	high	PROM and I/O write enable strobe
$\overline{\text{OE}}$	O	U19	high	PROM and I/O output enable
$\overline{\text{IOS}}$	O	T20	high	I/O area chip select
$\overline{\text{ROMS}}[0]$	O	V22	high	PROM chip select
$\overline{\text{ROMS}}[1]$	O	U20	high	PROM chip select
$\overline{\text{RWE}}[0]$	O	U22	high	SRAM write enable strobe
$\overline{\text{RWE}}[1]$	O	T19	high	SRAM write enable strobe
$\overline{\text{RWE}}[2]$	O	T22	high	SRAM write enable strobe
$\overline{\text{RWE}}[3]$	O	T21	high	SRAM write enable strobe
$\overline{\text{RAMOE}}[0]$	O	V20	high	SRAM output enable
$\overline{\text{RAMOE}}[1]$	O	R21	high	SRAM output enable
$\overline{\text{RAMOE}}[2]$	O	R20	high	SRAM output enable
$\overline{\text{RAMOE}}[3]$	O	R22	high	SRAM output enable
$\overline{\text{RAMOE}}[4]$	O	R19	high	SRAM output enable
$\overline{\text{RAMS}}[0]$	O	P22	high	SRAM chip select

Pin Name	Direction	Pin Number	Reset Value	Description
		484 CLGA		
$\overline{\text{RAMS}}[1]$	O	P20	high	SRAM chip select
$\overline{\text{RAMS}}[2]$	O	P21	high	SRAM chip select
$\overline{\text{RAMS}}[3]$	O	P19	high	SRAM chip select
$\overline{\text{RAMS}}[4]$	O	N19	high	SRAM chip select
READ	O	K20	high	SRAM, PROM, and I/O read indicator
$\overline{\text{BEXC}}$	I	K22	--	Bus exception
$\overline{\text{BRDY}}$	I	K21	--	Bus ready

## 2.6 SDRAM

Pin Name	Direction	Pin Number	Reset Value	Description
		484 CLGA		
SDCLK	O	AB12	high	SDRAM clock
$\overline{\text{SDRAS}}$	O	N22	high	SDRAM row address strobe
$\overline{\text{SDCAS}}$	O	N20	high	SDRAM column address strobe
$\overline{\text{SDWE}}$	O	N21	high	SDRAM write enable
$\overline{\text{SDCS}}[0]$	O	M21	high	SDRAM chip select
$\overline{\text{SDCS}}[1]$	O	M22	high	SDRAM chip select
SDDQM[0]	O	L21	high	SDRAM data mask
SDDQM[1]	O	M20	high	SDRAM data mask
SDDQM[2]	O	L20	high	SDRAM data mask
SDDQM[3]	O	L22	high	SDRAM data mask

## 2.7 CAN 2.0 Interface

Pin Name	Direction	Pin Number	Reset Value	Description
		484 CLGA		
CAN_RXD[0]	I	J20	--	CAN receive data
CAN_TXD[0]	O	J22	high	CAN transmit data

Pin Name	Direction	Pin Number	Reset Value	Description
		484 CLGA		
CAN_RXD[1]	I	J21	--	CAN receive data
CAN_TXD[1]	O	H22	high	CAN transmit data

## 2.8 Debug Support Unit (DSU)

Pin Name	Direction	Pin Number	Reset Value	Description
		484 CLGA		
DSUACT	O	H19	low	DSU mode indicator
DSUBRE	I	H20	--	DSU break
DSUEN	I	G19	--	DSU enable
DSURX	I	G20	--	DSU UART receive data
DSUTX	O	G21	high	DSU UART transmit data

## 2.9 JTAG Interface

Pin Name	Direction	Pin Number	Reset Value	Description
		484 CLGA		
$\overline{\text{TRST}}$	I	F20	--	JTAG reset
$\overline{\text{TMS}}$	I	F21	--	JTAG test mode select
TCK	I	G22	--	JTAG clock
TDI	I	F22	--	JTAG test data input
TDO	O	F19	undef	JTAG test data output

## 2.10 Ethernet Interface

Pin Name	Direction	Pin Number	Reset Value	Description
		484 CLGA		
EMDC	O	E22	low	Ethernet media interface clock
ERX_CLK	I	D22	--	Ethernet RX clock

Pin Name	Direction	Pin Number	Reset Value	Description
		484 CLGA		
EMDIO	I/O	D20	high-z	Ethernet media interface data
ERX_COL	I	E21	--	Ethernet collision error
ERX_CRS	I	E20	--	Ethernet carrier sense detect
ERX_DV	I	D21	--	Ethernet receiver data valid
ERX_ER	I	C21	--	Ethernet reception error
ERXD[0]	I	C22	--	Ethernet receive data
ERXD[1]	I	B21	--	Ethernet receive data
ERXD[2]	I	C20	--	Ethernet receive data
ERXD[3]	I	B20	--	Ethernet receive data
ETXD[0]	O	C19	low	Ethernet transmit data
ETXD[1]	O	C18	high	Ethernet transmit data
ETXD[2]	O	B18	low	Ethernet transmit data
ETXD[3]	O	B19	high	Ethernet transmit data
ETX_CLK	I	A19	--	Ethernet TX clock
ETX_EN	O	A18	low	Ethernet transmit enable
ETX_ER	O	A20	low	Ethernet transmit error. Always driven low.

## 2.11 General Purpose I/O

Pin Name	Direction	Pin Number	Reset Value	Description
		484 CLGA		
GPIO[0]	I/O	B17	high-z	Bit 0 of general purpose I/O
GPIO[1]	I/O	C17	high-z	Bit 1 of general purpose I/O
GPIO[2]	I/O	A17	high-z	Bit 2 of general purpose I/O
GPIO[3]	I/O	D17	high-z	Bit 3 of general purpose I/O
GPIO[4]	I/O	C16	high-z	Bit 4 of general purpose I/O
GPIO[5]	I/O	D16	high-z	Bit 5 of general purpose I/O
GPIO[6]	I/O	C15	high-z	Bit 6 of general purpose I/O
GPIO[7]	I/O	D15	high-z	Bit 7 of general purpose I/O

Pin Name	Direction	Pin Number	Reset Value	Description
		484 CLGA		
GPIO[8]	I/O	C7	high-z	Bit 8 of general purpose I/O
GPIO[9]	I/O	B5	high-z	Bit 9 of general purpose I/O
GPIO[10]	I/O	D7	high-z	Bit 10 of general purpose I/O
GPIO[11]	I/O	A5	high-z	Bit 11 of general purpose I/O
GPIO[12]	I/O	D6	high-z	Bit 12 of general purpose I/O
GPIO[13]	I/O	C5	high-z	Bit 13 of general purpose I/O
GPIO[14]	I/O	C6	high-z	Bit 14 of general purpose I/O
GPIO[15]	I/O	D5	high-z	Bit 15 of general purpose I/O

## 2.12 SpaceWire Interface

Pin Name	Direction	Pin Number	Reset Value	Description
		484 CLGA		
SPW_CLK	I	A11	--	SpaceWire clock
SPW_RXS[0]	I	A16	--	SpaceWire receive strobe
SPW_RXD[0]	I	A15	--	SpaceWire receive data
SPW_TXS[0]	O	B16	low	SpaceWire transmit strobe
SPW_TXD[0]	O	B15	low	SpaceWire transmit data
SPW_RXS[1]	I	A14	--	SpaceWire receive strobe
SPW_RXD[1]	I	A13	--	SpaceWire receive data
SPW_TXS[1]	O	B14	low	SpaceWire transmit strobe
SPW_TXD[1]	O	B13	low	SpaceWire transmit data
SPW_RXS[2]	I	A9	--	SpaceWire receive strobe
SPW_RXD[2]	I	A8	--	SpaceWire receive data
SPW_TXS[2]	O	B9	low	SpaceWire transmit strobe
SPW_TXD[2]	O	B8	low	SpaceWire transmit data
SPW_RXS[3]	I	A7	--	SpaceWire receive strobe
SPW_RXD[3]	I	A6	--	SpaceWire receive data
SPW_TXS[3]	O	B7	low	SpaceWire transmit strobe

Pin Name	Direction	Pin Number	Reset Value	Description
		484 CLGA		
SPW_TXD[3]	O	B6	low	SpaceWire transmit data

### 2.13 UART Interface

Pin Name	Direction	Pin Number	Reset Value	Description
		484 CLGA		
RXD	I	C12	--	UART receive data
TXD	O	C11	high	UART transmit data

### 2.14 PCI Address and Data Bus

Pin Name	Direction	Pin Number	Reset Value	Description
		484 CLGA		
PCI_AD[0]	PCI-I/O	AA2	high-z	Bit 0 of PCI address and data bus
PCI_AD[1]	PCI-I/O	AA3	high-z	Bit 1 of PCI address and data bus
PCI_AD[2]	PCI-I/O	Y1	high-z	Bit 2 of PCI address and data bus
PCI_AD[3]	PCI-I/O	Y2	high-z	Bit 3 of PCI address and data bus
PCI_AD[4]	PCI-I/O	Y3	high-z	Bit 4 of PCI address and data bus
PCI_AD[5]	PCI-I/O	W1	high-z	Bit 5 of PCI address and data bus
PCI_AD[6]	PCI-I/O	W2	high-z	Bit 6 of PCI address and data bus
PCI_AD[7]	PCI-I/O	W3	high-z	Bit 7 of PCI address and data bus
PCI_AD[8]	PCI-I/O	V2	high-z	Bit 8 of PCI address and data bus
PCI_AD[9]	PCI-I/O	V3	high-z	Bit 9 of PCI address and data bus
PCI_AD[10]	PCI-I/O	U1	high-z	Bit 10 of PCI address and data bus
PCI_AD[11]	PCI-I/O	U2	high-z	Bit 11 of PCI address and data bus
PCI_AD[12]	PCI-I/O	U3	high-z	Bit 12 of PCI address and data bus
PCI_AD[13]	PCI-I/O	T1	high-z	Bit 13 of PCI address and data bus
PCI_AD[14]	PCI-I/O	R2	high-z	Bit 14 of PCI address and data bus
PCI_AD[15]	PCI-I/O	R1	high-z	Bit 15 of PCI address and data bus

Pin Name	Direction	Pin Number	Reset Value	Description
		484 CLGA		
PCI_AD[16]	PCI-I/O	J1	high-z	Bit 16 of PCI address and data bus
PCI_AD[17]	PCI-I/O	K2	high-z	Bit 17 of PCI address and data bus
PCI_AD[18]	PCI-I/O	K1	high-z	Bit 18 of PCI address and data bus
PCI_AD[19]	PCI-I/O	G1	high-z	Bit 19 of PCI address and data bus
PCI_AD[20]	PCI-I/O	H3	high-z	Bit 20 of PCI address and data bus
PCI_AD[21]	PCI-I/O	H2	high-z	Bit 21 of PCI address and data bus
PCI_AD[22]	PCI-I/O	F1	high-z	Bit 22 of PCI address and data bus
PCI_AD[23]	PCI-I/O	F2	high-z	Bit 23 of PCI address and data bus
PCI_AD[24]	PCI-I/O	E1	high-z	Bit 24 of PCI address and data bus
PCI_AD[25]	PCI-I/O	E2	high-z	Bit 25 of PCI address and data bus
PCI_AD[26]	PCI-I/O	F3	high-z	Bit 26 of PCI address and data bus
PCI_AD[27]	PCI-I/O	D1	high-z	Bit 27 of PCI address and data bus
PCI_AD[28]	PCI-I/O	D2	high-z	Bit 28 of PCI address and data bus
PCI_AD[29]	PCI-I/O	E3	high-z	Bit 29 of PCI address and data bus
PCI_AD[30]	PCI-I/O	D3	high-z	Bit 30 of PCI address and data bus
PCI_AD[31]	PCI-I/O	C1	high-z	Bit 31 of PCI address and data bus

## 2.15 PCI Control Signals

Pin Name	Direction	Pin Number	Reset Value	Description
		484 CLGA		
$\overline{\text{PCI\_RST}}$	PCI-I	C3	--	PCI reset input
PCI_CLK	PCI-I	C2	--	PCI clock input
PCI_C/ $\overline{\text{BE}}$ [0]	PCI-I/O	V1	high-z	PCI bus command and byte enable
PCI_C/ $\overline{\text{BE}}$ [1]	PCI-I/O	P2	high-z	PCI bus command and byte enable
PCI_C/ $\overline{\text{BE}}$ [2]	PCI-I/O	H1	high-z	PCI bus command and byte enable
PCI_C/ $\overline{\text{BE}}$ [3]	PCI-I/O	G2	high-z	PCI bus command and byte enable
PCI_PAR	PCI-I/O	P1	high-z	PCI parity checkbit
$\overline{\text{PCI\_FRAME}}$ <sup>1</sup>	PCI-3	L1	high-z	PCI cycle frame indicator

Pin Name	Direction	Pin Number	Reset Value	Description
		484 CLGA		
$\overline{\text{PCI\_IRDY}}^1$	PCI-3	L2	high-z	PCI initiator ready indicator
$\overline{\text{PCI\_TRDY}}^1$	PCI-3	M1	high-z	PCI target ready indicator
$\overline{\text{PCI\_STOP}}^1$	PCI-3	N1	high-z	PCI target stop request
$\overline{\text{PCI\_DEVSEL}}^1$	PCI-3	M2	high-z	PCI device select
$\overline{\text{PCI\_PERR}}^1$	PCI-3	N2	high-z	PCI parity error indicator
PCI_IDSEL	PCI-I	G3	--	PCI initialization device select
$\overline{\text{PCI\_REQ}}$	PCI-O	A4	high-z	PCI request to arbiter in point to point configuration
$\overline{\text{PCI\_GNT}}$	PCI-I	B2	--	PCI bus access indicator in point to point configuration
$\overline{\text{PCI\_HOST}}$	PCI-I	AB3	--	PCI host enable input (Connect to $\overline{\text{SYSEN}}$ in PCI bus)

**Notes:**

1. This pin must be tied to  $V_{DD}$  through a pull-up resistor as specified in the PCI Local Bus Specification Revision 2.1 Section 4.3.3.

## 2.16 PCI Arbiter

Pin Name	Direction	Pin Number	Reset Value	Description
		484 CLGA		
$\overline{\text{PCI\_ARB\_REQ}}[0]$	PCI-I	B4	--	PCI arbiter bus request
$\overline{\text{PCI\_ARB\_REQ}}[1]$	PCI-I	AB4	--	PCI arbiter bus request
$\overline{\text{PCI\_ARB\_REQ}}[2]$	PCI-I	Y4	--	PCI arbiter bus request
$\overline{\text{PCI\_ARB\_REQ}}[3]$	PCI-I	T3	--	PCI arbiter bus request
$\overline{\text{PCI\_ARB\_REQ}}[4]$	PCI-I	P3	--	PCI arbiter bus request
$\overline{\text{PCI\_ARB\_REQ}}[5]$	PCI-I	M3	--	PCI arbiter bus request
$\overline{\text{PCI\_ARB\_REQ}}[6]$	PCI-I	K3	--	PCI arbiter bus request
$\overline{\text{PCI\_ARB\_REQ}}[7]$	PCI-I	C4	--	PCI arbiter bus request
$\overline{\text{PCI\_ARB\_GNT}}[0]$	PCI-O	B3	high-z	PCI arbiter bus grant
$\overline{\text{PCI\_ARB\_GNT}}[1]$	PCI-O	AA4	high-z	PCI arbiter bus grant
$\overline{\text{PCI\_ARB\_GNT}}[2]$	PCI-O	W4	high-z	PCI arbiter bus grant
$\overline{\text{PCI\_ARB\_GNT}}[3]$	PCI-O	R3	high-z	PCI arbiter bus grant

Pin Name	Direction	Pin Number	Reset Value	Description
		484 CLGA		
$\overline{\text{PCI\_ARB\_GNT}}[4]$	PCI-O	N3	high-z	PCI arbiter bus grant
$\overline{\text{PCI\_ARB\_GNT}}[5]$	PCI-O	L3	high-z	PCI arbiter bus grant
$\overline{\text{PCI\_ARB\_GNT}}[6]$	PCI-O	J3	high-z	PCI arbiter bus grant
$\overline{\text{PCI\_ARB\_GNT}}[7]$	PCI-O	A3	high-z	PCI arbiter bus grant

## 2.17 Power and Ground Pins

Pin Name	Pin Number	Description
	484 CLGA	
$V_{DD}$	B1, B10, B12, B22, E7, E9, E14, E16, F6, F10, F13, F17, G5, G9, G14, H6, H8, H10, H13, H15, J7, J16, J18, K5, K8, K15, K17, L6, M6, N5, N8, N15, N17, P7, P16, P18, R6, R8, R10, R13, R15, T5, T9, T14, U6, U9, U11, U12, U14, U17, V10, V13, AA1, AA22	I/O supply voltage
$V_{SS}$	A1, A12, A22, B11, C8, C10, C13, D4, D9, D14, D18, E4, E6, E10, E13, E17, E19, F4, G4, G8, G11, G12, G15, G17, H4, H7, H16, H18, J2, J4, J9, J14, K4, K10, K13, L7, L11, L12, L17, M7, M11, M12, M17, N4, N10, N13, P4, P9, P14, R4, R7, R16, R18, T2, T4, T8, T15, T17, U4, U10, U13, V4, V5, V8, V11, V12, V15, V18, AB1, AB22	I/O supply ground
$V_{DDC}$	A2, A21, D10, D13, E5, E11, E12, E18, F8, F15, G7, G10, G13, G16, G18, H5, H9, H11, H12, H14, H17, J6, J8, J15, K7, K16, L4, L8, L15, L18, M4, M8, M15, M18, N7, N16, P6, P8, P15, R5, R9, R11, R12, R14, R17, T7, T10, T13, T16, T18, U8, U15, V6, V17, AB2, AB21	Core supply voltage
$V_{SSC}$	A10, C9, C14, D11, D12, E8, E15, F5, F7, F9, F11, F12, F14, F16, F18, G6, H21, J5, J10, J11, J12, J13, J17, K6, K9, K11, K12, K14, K18, L5, L9, L10, L13, L14, L16, M5, M9, M10, M13, M14, M16, M19, N6, N9, N11, N12, N14, N18, P5, P10, P11, P12, P13, P17, T6, T11, T12, U5, U7, U16, U18, U21, V7, V9, V14, V16	Core supply ground
Unused	D8	This pin may be left floating or tied to $V_{SS}$
Unused	D19	This pin must be tied to $V_{SS}$

## 2.20 Bootstrap Signals

The states of the following signals are latched in upon the rising edge of reset in order to configure the UT699E for the indicated operation.

Pin Name	Function
GPIO[1:0]	Sets the data width of the PROM area 00: 8 bits 01: 16 bits 10: 32 bits 11: Not used
GPIO[2]	Enable EDAC checking of the PROM area 0: EDAC disabled 1: EDAC enabled

### 3.0 AC and DC Electrical Specifications

#### 3.1 Absolute Maximum Ratings<sup>1</sup>

Symbol	Description		Min	Max	Units
$V_{DDC}$	Core supply voltage		-0.3	1.85	V
$V_{DD}$	I/O supply voltage		-0.3	5.2	V
$V_{IN}$	Input voltage any pin		$V_{SS} - 0.3$	$V_{DD} + 0.3$	V
$P_D$ <sup>2</sup>	Maximum power dissipation permitted @ $T_C = 105^\circ\text{C}$		--	4	W
$T_J$ <sup>3</sup>	Junction temperature		--	125	$^\circ\text{C}$
$\Theta_{JC}$	Thermal resistance, junction to case	484 CLGA/CCGA/CBGA	--	5	$^\circ\text{C}/\text{W}$
$T_{STG}$	Storage temperature		-65	150	$^\circ\text{C}$
$ESD_{HBM}$	ESD protection (human body model) Class 2		2000	--	V

**Notes:**

1. Stresses greater than those listed in the following table can result in permanent damage to the device. These parameters cannot be violated.
2. Per MIL-STD-883, Method 1012, Section 3.4.1,  $PD = (T_J(\text{max}) - T_C(\text{max})) / \Theta_{JC}$
3. Maximum junction temperature may be increased to  $175^\circ\text{C}$  during burn-in and steady-static life testing.

### 3.2 Recommended Operating Conditions

( $V_{DD} = 3.3V \pm 0.3V$ ;  $V_{DDC} = 1.2V \pm 0.1V$ ;  $T_C = -55^{\circ}C$  to  $105^{\circ}C$ )

Symbol	Description	Min	Max	Units
$V_{DDC}$	Core supply voltage	1.1	1.3	V
$V_{DD}$	I/O supply voltage	3.0	3.6	V
$V_{IN}$	Input voltage any pin	0	$V_{DD}$	V
$T_C$	Case operating temperature	-55	105	$^{\circ}C$
$t_R$	Rise time, all CMOS and PCI inputs ( $0.1V_{DD}$ to $0.9V_{DD}$ )	--	20	ns
$t_F$	Fall time, all CMOS and PCI inputs ( $0.9V_{DD}$ to $0.1V_{DD}$ )	--	20	ns

### 3.3 Power Supply Operating Characteristics (pre- and post-radiation)

( $V_{DD} = 3.3V \pm 0.3V$ ;  $V_{DDC} = 1.2V \pm 0.1V$ ;  $T_C = -55^{\circ}C$  to  $105^{\circ}C$ )

Symbol	Description	Conditions	Max	Units	
$I_{DDCS}$	Standby core power supply quiescent current	$V_{DDC} = 1.3V$ , $V_{DD} = 3.6V$ All clock inputs at 0MHz	$T_C = -55^{\circ}C$ and $25^{\circ}C$	20	mA
			$T_C = 105^{\circ}C$	170	
$I_{DDS}$	Standby I/O power supply quiescent current	$V_{DDC} = 1.3V$ , $V_{DD} = 3.6V$ All clock inputs at 0MHz	$T_C = -55^{\circ}C$ and $25^{\circ}C$	0.7	mA
			$T_C = 105^{\circ}C$	2	

### 3.4 DC Characteristics for LVCMOS3 Inputs (pre- and post-radiation)

( $V_{DD} = 3.3V \pm 0.3V$ ;  $V_{DDC} = 1.2V \pm 0.1V$ ;  $T_C = -55^{\circ}C$  to  $105^{\circ}C$ )

Symbol	Description	Conditions	Min	Max	Units
$V_{IH}^1$	High-level input voltage		$0.7V_{DD}$	--	V
$V_{IL}^1$	Low-level input voltage		--	$0.3V_{DD}$	V
$V_{T+}$	Positive going threshold voltage for Schmitt inputs		--	$0.7V_{DD}$	V
$V_{T-}$	Negative going threshold voltage for Schmitt inputs		$0.3V_{DD}$	--	V
$V_H$	Hysteresis voltage for Schmitt inputs		0.4	--	V
$I_{IN}$	Input leakage current	$V_{IN} = V_{DD}$	--	1	$\mu A$
		$V_{IN} = V_{SS}$	-1	--	
$C_{IN}^2$	Input pin capacitance	$f = 1MHz$ ; $V_{DD} = 0V$ , $V_{DDC} = 0V$	--	16	pF

**Notes:**

1. JTAG inputs are not tested.
2. Capacitance is measured for initial qualification and when design changes might affect the input/output capacitance.

### 3.5 DC Characteristics for LVCMOS3 Outputs (pre- and post-radiation)

( $V_{DD} = 3.3V \pm 0.3V$ ;  $V_{DDC} = 1.2V \pm 0.1V$ ;  $T_C = -55^{\circ}C$  to  $105^{\circ}C$ )

Symbol	Description	Conditions	Min	Max	Units
$V_{OL1}^1$	Low-level output voltage (All outputs except those listed below and in Section 3.8)	$I_{OL} = 100\mu A$	--	0.25	V
		$I_{OL} = 4mA$	--	0.4	
$V_{OH1}^{1,2}$	High-level output voltage (All outputs except those listed below and in Section 3.8)	$I_{OH} = -100\mu A$	$V_{DD}-0.25$	--	V
		$I_{OH} = -4mA$	2.4	--	
$V_{OL2}$	Low-level output voltage (GPIO[15:0], SPW_TXD[3:0], SPW_TXS[3:0], TXD)	$I_{OL} = 100\mu A$	--	0.25	V
		$I_{OL} = 12mA$	--	0.4	
$V_{OH2}$	High-level output voltage (GPIO[15:0], SPW_TXD[3:0], SPW_TXS[3:0], TXD)	$I_{OH} = -100\mu A$	$V_{DD}-0.25$	--	V
		$I_{OH} = -12mA$	2.4	--	
$V_{OL3}$	Low-level output voltage ( $\overline{WRITE}$ , $\overline{OE}$ , $\overline{IOS}$ , $\overline{ROMS}[1:0]$ , $\overline{RWE}[3:0]$ , $\overline{RAMOE}[4:0]$ , $\overline{RAMS}[4:0]$ , $\overline{SDCS}[1:0]$ , $\overline{SDRAS}$ , $\overline{SDCAS}$ , $\overline{SDWE}$ , $\overline{SDCLK}$ , $\overline{READ}$ , $\overline{SDDQM}[3:0]$ , $\overline{ADDR}[27:0]$ , $\overline{DATA}[31:0]$ and $\overline{CB}[7:0]$ )	$I_{OL} = 100\mu A$	--	0.25	V
		$I_{OL} = 24mA$	--	0.4	
$V_{OH3}$	High-level output voltage ( $\overline{WRITE}$ , $\overline{OE}$ , $\overline{IOS}$ , $\overline{ROMS}[1:0]$ , $\overline{RWE}[3:0]$ , $\overline{RAMOE}[4:0]$ , $\overline{RAMS}[4:0]$ , $\overline{SDCS}[1:0]$ , $\overline{SDRAS}$ , $\overline{SDCAS}$ , $\overline{SDWE}$ , $\overline{SDCLK}$ , $\overline{READ}$ , $\overline{SDDQM}[3:0]$ , $\overline{ADDR}[27:0]$ , $\overline{DATA}[31:0]$ and $\overline{CB}[7:0]$ )	$I_{OH} = -100\mu A$	$V_{DD}-0.25$	--	V
		$I_{OH} = -24mA$	2.4	--	
$I_{OZ}$	Three-state output current	$V_O = V_{DD}$	-10	10	$\mu A$
		$V_O = V_{SS}$	-10	10	
$I_{OS}^3$	Short-circuit output current (All outputs except PCI outputs)	$V_O = V_{DD}$ ; $V_{DD} = 3.6V$	--	130	mA
		$V_O = V_{SS}$ ; $V_{DD} = 3.6V$	-65	--	
$C_{OUT}^4$	Output pin capacitance	$f = 1MHz$ ; $V_{DD} = 0V$ , $V_{DDC} = 0V$	--	16	pF

**Notes:**

- JTAG outputs are not tested.
- Except open-drain output.
- Guaranteed by design.
- Capacitance is measured for initial qualification and when design changes might affect the input/output capacitance.

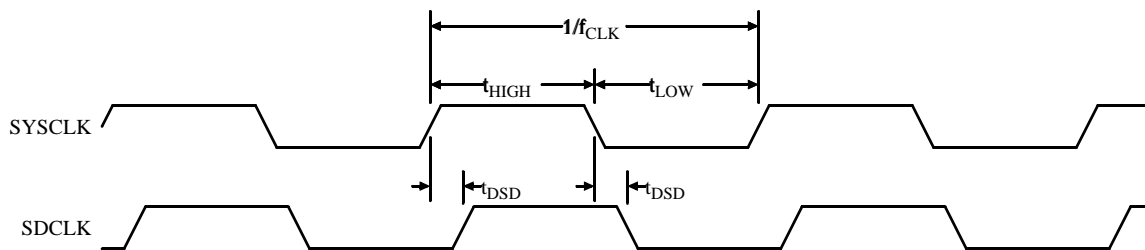
### 3.6 AC Electrical Characteristics for LVCMOS3 Inputs and Outputs (pre- and post-radiation)

( $V_{DD} = 3.3V \pm 0.3V$ ;  $V_{DDC} = 1.2V \pm 0.1V$ ;  $T_C = -55^{\circ}C$  to  $105^{\circ}C$ )

Symbol	Description	Conditions	Min	Max	Units
$f_{CLK}$	System clock frequency		--	100	MHz
$t_{HIGH}$	System clock high time		4	--	ns
$t_{LOW}$	System clock low time		4	--	ns
$t_{DSD}^1$	System clock to SDRAM clock propagation delay		2.3	6.5	ns

**Notes:**

1. Reference Figure 15 for test load.



**Figure 2. System Clock and SDCLK Timing Diagram**

### 3.7 DC Electrical Characteristics for PCI Inputs (pre- and post-radiation)

( $V_{DD} = 3.3V \pm 0.3V$ ;  $V_{DDC} = 1.2V \pm 0.1V$ ;  $T_C = -55^{\circ}C$  to  $105^{\circ}C$ )

Symbol	Description	Conditions	Min	Max	Units
$V_{IH}$	High-level input voltage		$0.5V_{DD}$	--	V
$V_{IL}$	Low-level input voltage		--	$0.3V_{DD}$	V
$I_{IN}$	Input leakage current	$V_{IN} = V_{DD}$	--	80	$\mu A$
		$V_{IN} = V_{SS}$	-80	--	
$C_{IN}^1$	Input pin capacitance	$f = 1MHz$ ; $V_{DD} = 0V$ , $V_{DDC} = 0V$	--	22	pF

**Notes:**

1. Capacitance is measured for initial qualification and when design changes might affect the input/output capacitance.

### 3.8 DC Electrical Characteristics for PCI Outputs (pre- and post-radiation)

( $V_{DD} = 3.3V \pm 0.3V$ ;  $V_{DDC} = 1.2V \pm 0.1V$ ;  $T_C = -55^{\circ}C$  to  $105^{\circ}C$ )

Symbol	Description	Conditions	Min	Max	Units
$V_{OH}$	High-level output voltage ( $\overline{PCI\_AD[31:0]}$ , $\overline{PCI\_C/BE[3:0]}$ , $\overline{PCI\_RST}$ , $\overline{PCI\_IDSEL}$ , $\overline{PCI\_FRAME}$ , $\overline{PCI\_IRDY}$ , $\overline{PCI\_TRDY}$ , $\overline{PCI\_DEVSEL}$ , $\overline{PCI\_STOP}$ , $\overline{PCI\_PERR}$ , $\overline{PCI\_PAR}$ )	$I_{OH} = -500\mu A$	$0.9V_{DD}$	--	V
$V_{OL}$	Low-level output voltage ( $\overline{PCI\_AD[31:0]}$ , $\overline{PCI\_C/BE[3:0]}$ , $\overline{PCI\_RST}$ , $\overline{PCI\_IDSEL}$ , $\overline{PCI\_FRAME}$ , $\overline{PCI\_IRDY}$ , $\overline{PCI\_TRDY}$ , $\overline{PCI\_DEVSEL}$ , $\overline{PCI\_STOP}$ , $\overline{PCI\_PERR}$ , $\overline{PCI\_PAR}$ )	$I_{OL} = 1500\mu A$	--	$0.1V_{DD}$	V
$I_{OZ}$	Three-state output current	$V_O = V_{DD}$	-10	80	$\mu A$
		$V_O = V_{SS}$	-80	10	
$I_{OS}^1$	Short-circuit output current	$V_O = V_{DD}$ ; $V_{DD} = 3.6V$	--	270	mA
		$V_O = V_{SS}$ ; $V_{DD} = 3.6V$	-130	--	
$C_{OUT}^2$	Output pin capacitance	$f = 1MHz$ ; $V_{DD} = 0V$ , $V_{DDC} = 0V$	--	22	pF

**Notes:**

1. Guaranteed by design.

2. Capacitance is measured for initial qualification and when design changes might affect the input/output capacitance.

### 3.9 AC Electrical Characteristics for PCI Inputs (pre- and post-radiation)

( $V_{DD} = 3.3V \pm 0.3V$ ;  $V_{DDC} = 1.2V \pm 0.1V$ ;  $T_C = -55^{\circ}C$  to  $105^{\circ}C$ )

Symbol	Description	Conditions	Min	Max	Units
$f_{PCI\_CLK}$	PCI clock frequency		--	33	MHz
$t_{HIGH}$	PCI clock high time		11	--	ns
$t_{LOW}$	PCI clock low time		11	--	ns

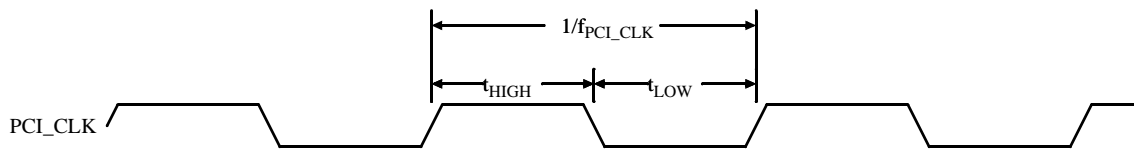


Figure 3. PCI Clock Timing Diagram

## 4.0 Timing Specifications

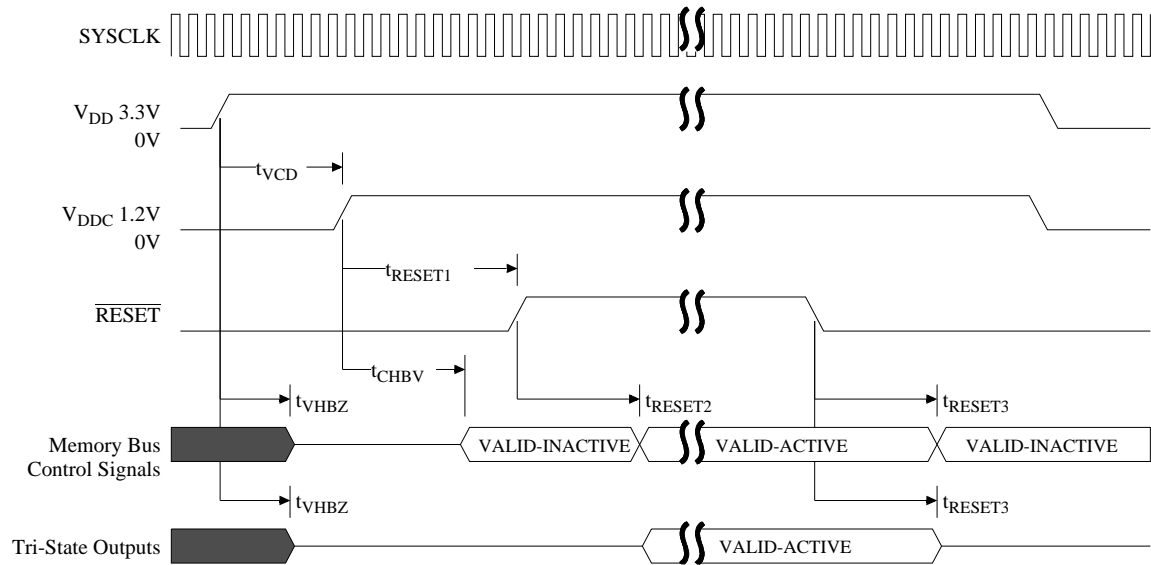
### 4.1 Power Sequencing and Reset

( $V_{DD} = 3.3V \pm 0.3V$ ;  $V_{DDC} = 1.2V \pm 0.1V$ ;  $T_C = -55^{\circ}C$  to  $105^{\circ}C$ )

Symbol	Description	Conditions	Min	Max	Units
$t_{VCD}^1$	$V_{DD}$ valid to $V_{DDC}$ delay	$V_{DD} \geq 3.0V$ ; $V_{DDC} \geq 1.1V$	0	--	ns
$t_{VHBZ}^1$	$V_{DD}$ valid to control signals high-z ( $\overline{WRITE}$ , $\overline{OE}$ , $\overline{IOS}$ , $\overline{ROMS}[1:0]$ , $\overline{RWE}[3:0]$ , $\overline{RAMOE} [4:0]$ , $\overline{READ}$ $\overline{SDWE}$ , and $\overline{SDCS}[1:0]$ )  $V_{DD}$ valid to outputs high-z ( $DATA[31:0]$ , $CB[7:0]$ , and $GPIO[15:0]$ )	$V_{DD} \geq 1.5V$ ; $V_{DDC} = 0V$	--	4	$t_{CLK}$
$t_{CHBV}^1$	$V_{DDC}$ valid to control signals valid-inac- tive ( $\overline{WRITE}$ , $\overline{OE}$ , $\overline{IOS}$ , $\overline{ROMS}[1:0]$ , $\overline{RWE}[3:0]$ , $\overline{RAMOE} [4:0]$ , $\overline{READ}$ $\overline{SDWE}$ , and $\overline{SDCS}[1:0]$ )	$V_{DD} \geq 3.0V$ ; $V_{DDC} \geq 1.1V$	--	4	$t_{CLK}$
$t_{RESET1}^1$	$V_{DDC}$ valid to $\overline{RESET}$ deassert	$V_{DDC} \geq 1.1V$	4	--	$t_{CLK}$
$t_{RESET2}^1$	$\overline{RESET}$ deasserted to outputs valid-active ( $\overline{ROMS}[0]$ and $\overline{OE}$ )		--	12	$t_{CLK}$
$t_{RESET3}^1$	$\overline{RESET}$ asserted to control signals valid- inactive ( $\overline{WRITE}$ , $\overline{OE}$ , $\overline{IOS}$ , $\overline{ROMS}[1:0]$ , $\overline{RWE}[3:0]$ , $\overline{RAMOE} [4:0]$ , $\overline{READ}$ $\overline{SDWE}$ , and $\overline{SDCS}[1:0]$ )  $\overline{RESET}$ asserted to outputs high-z ( $DATA[31:0]$ , $CB[7:0]$ , and $GPIO[15:0]$ )		--	4	$t_{CLK}$

#### Notes:

1. Guaranteed by design.



**Figure 4. Power Sequencing and Reset Timing Diagram**

#### 4.1.1. Power Sequencing

Proper power sequencing of the UT699E is achieved by bringing  $V_{DD}$  up to its minimum operating voltage of 3.0V, and then delaying  $t_{VCD}$  clock cycles before bringing up the  $V_{DDC}$  supply. **If power is applied to the  $V_{DDC}$  supply pins while  $V_{DD}$  is less than 3.0V, excessive current or damage to the device could occur.**

#### 4.1.2 Bus Control and Bi-Direct Fail-Safe Circuitry

In order to prevent bus contention on the external memory interface while  $V_{DDC}$  is ramping up, the UT699E has functionality to ensure that the bi-direct and memory bus control signals described in Section 4.1 will be in a high-z state  $t_{VHBZ}$  delay after  $V_{DD}$  reaches 1.5V. The core logic will put these signals into their valid-inactive states  $t_{CHBV}$  clock cycles after  $V_{DDC}$  reaches 1.1V.

Aeroflex recommends that users place pull-up resistors on the indicated output enable, write enable, and chip select pins, and a pull-down resistor on the READ pin, if  $t_{VCD}$  is greater than 100ns. This will prevent bus capacitance or transients from inadvertently placing these pins in an active state, which could result in external memory devices driving the address and data buses.

#### 4.1.3 Reset Circuitry

The reset circuitry is controlled by the core logic; therefore, the circuitry is functional only after  $V_{DDC}$  reaches its minimum operating voltage of 1.1V. After  $V_{DDC}$  is stable, the system must continue to assert  $\overline{RESET}$  for a minimum of  $t_{RESET1}$  clock cycles before it can be de-asserted. Asserting  $\overline{RESET}$  for less time could result in the  $\overline{RESET}$  signal not being recognized.

The UT699E will begin fetching code from external memory no more than  $t_{RESET2}$  clock cycles after  $\overline{RESET}$  is de-asserted. Control signals  $\overline{ROMS[0]}$  and  $\overline{OE}$  will be driven to their valid-active states in order for the UT699E to begin fetching code from PROM. During normal operation, the indicated bus control signals will go to a valid-inactive state, and the bi-direcTs will go to a high-z state, within  $t_{RESET3}$  clock cycles after the assertion of  $\overline{RESET}$ .

#### *4.1.4 Programming Pins GPIO[2:0]*

Data on pins GPIO[2:0] are latched on the rising edge of reset. The states of these pins determine the data width of the PROM area, and enable EDAC for the PROM area. Chapter 3 of the User's Manual describes the value of these inputs to achieve the required operation.

In order for the state of GPIO[2:0] to be properly latched, Aeroflex recommends placing pull-up or pull-down resistors on these pins to ensure that the setup and hold timing is met. The states of these pins should be statically set prior to the rising edge of  $\overline{\text{RESET}}$ .

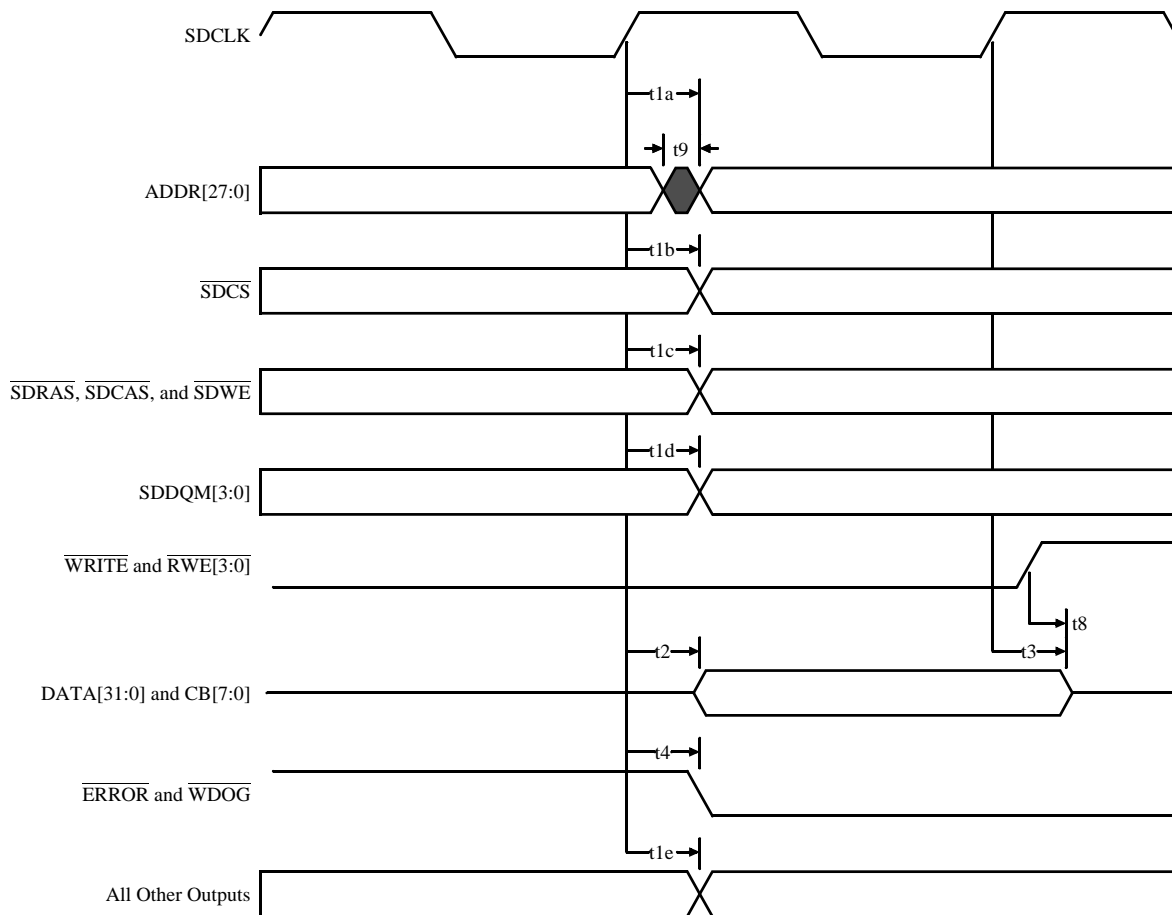
## 4.2 Output Timing Characteristics for Memory Interface, $\overline{\text{ERROR}}$ , and $\overline{\text{WDOG}}$

( $V_{DD} = 3.3V \pm 0.3V$ ;  $V_{DDC} = 1.2V \pm 0.1V$ ;  $T_C = -55^\circ\text{C}$  to  $105^\circ\text{C}$ )

Symbol	Description	Min	Max	Units
t1a <sup>1</sup>	SDCLK $\uparrow$ to ADDR[27:0] valid	1.5	8.5	ns
t1b <sup>1</sup>	SDCLK $\uparrow$ to $\overline{\text{SDCS}}[1:0]$ valid	2	7.5	ns
t1c <sup>1</sup>	SDCLK $\uparrow$ to output valid $\overline{\text{SDRAS}}$ , $\overline{\text{SDCAS}}$ , and $\overline{\text{SDWE}}$	1.5	8.5	ns
t1d <sup>1</sup>	SDCLK $\uparrow$ to SDDQM[3:0] valid	2.5	8.5	ns
t1e <sup>1</sup>	SDCLK $\uparrow$ to output valid $\overline{\text{WRITE}}$ , $\overline{\text{OE}}$ , $\overline{\text{IOS}}$ , $\overline{\text{ROMS}}[1:0]$ , $\overline{\text{RWE}} [3:0]$ , $\overline{\text{RAMOE}} [4:0]$ , $\overline{\text{RAMS}}[4:0]$ , and READ)	1	8	ns
t2 <sup>1,2</sup>	SDCLK $\uparrow$ to output valid (DATA[31:0] and CB[7:0])	2.5	8.5	ns
t3 <sup>1,2,3</sup>	SDCLK $\uparrow$ to output high-Z (DATA[31:0] and CB[7:0])	2.5	8.5	ns
t4 <sup>1,4</sup>	SDCLK $\uparrow$ to signal low $\overline{\text{ERROR}}$ and $\overline{\text{WDOG}}$	--	10	ns
t8 <sup>1,2,3</sup>	$\overline{\text{WRITE}}\uparrow$ or $\overline{\text{RWE}}[3:0]\uparrow$ to output high-z (DATA [31:0] and CB[7:0])	0.5	--	ns
t9 <sup>1</sup>	Skew from first memory output signal transition to last memory output signal transition	--	2	ns

### Notes:

1. All outputs are measured using the load conditions shown in Figure 15.
2. CB[7] is not tested.
3. High-Z defined as +/-300mV change from steady state.
4.  $\overline{\text{WDOG}}$  guaranteed by design.



**Figure 5. Memory Interface,  $\overline{\text{ERROR}}$ , and  $\overline{\text{WDOG}}$  Output Timing Diagram**

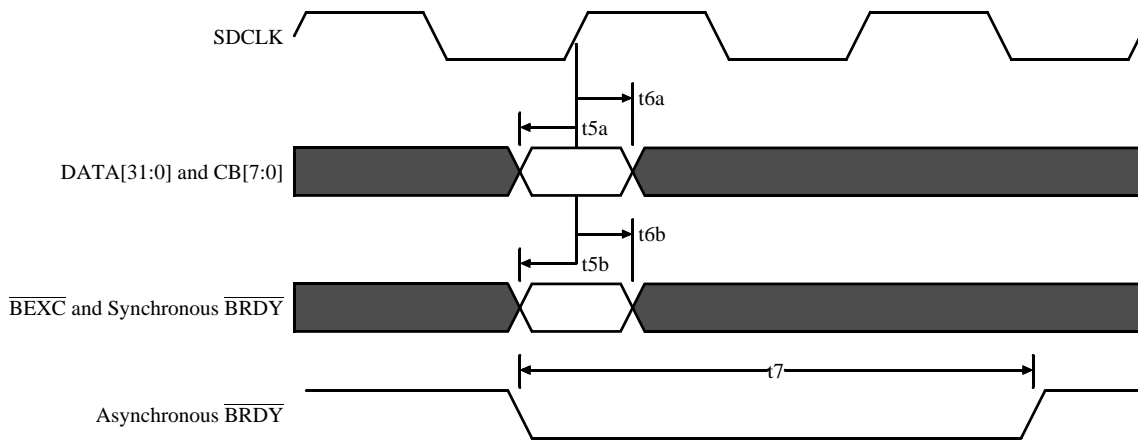
### 4.3 Input Timing Characteristics for Memory Interface

( $V_{DD} = 3.3V \pm 0.3V$ ;  $V_{DDC} = 1.2V \pm 0.1V$ ;  $T_C = -55^{\circ}C$  to  $105^{\circ}C$ )

Symbol	Description	Min	Max	Units
$t_{5a}^{1,2}$	Setup time to SDCLK $\uparrow$ (DATA[31:0] and CB[7:0])	1	--	ns
$t_{5b}$	Setup time to SDCLK $\uparrow$ ( $\overline{BEXC}$ , and synchronous $\overline{BRDY}$ )	2	--	ns
$t_{6a}^{1,2}$	Hold time from SDCLK $\uparrow$ (DATA[31:0] and CB[7:0])	1.5	--	ns
$t_{6b}$	Hold time from SDCLK $\uparrow$ (Synchronous $\overline{BRDY}$ )	0	--	ns
$t_7^3$	Asynchronous $\overline{BRDY}$ pulse width	1.5	--	$t_{CLK}$

**Notes:**

1. CB[7] is not tested.
2. CB[6:0] timing is guaranteed by design when used as inputs.
3. Supplied as a design limit. Neither guaranteed nor tested.



**Figure 6. Memory Interface Input Timing Diagram**

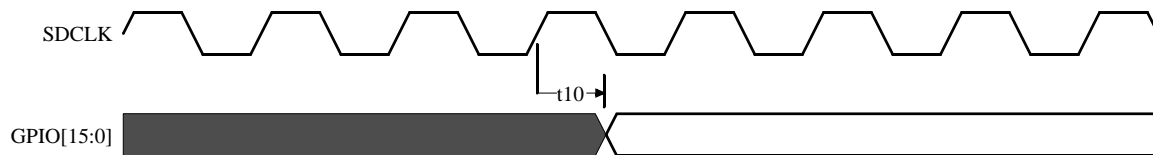
#### 4.4 Timing Characteristics for General Purpose Input / Output (GPIO)

( $V_{DD} = 3.3V \pm 0.3V$ ;  $V_{DDC} = 1.2V \pm 0.1V$ ;  $T_C = -55^{\circ}C$  to  $105^{\circ}C$ )

Symbol	Description	Min	Max	Units
$t_{10}^1$	SDCLK $\uparrow$ to GPIO output valid (GPIO[15:0])	--	10	ns

**Notes:**

1. All outputs are measured using the load conditions shown in Figure 15.



**Figure 7. General Purpose I/O Timing Diagram**

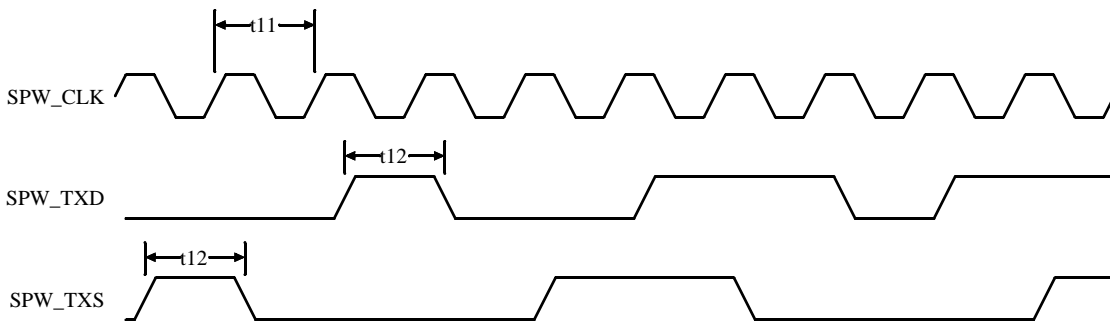
#### 4.5 Timing Characteristics SpaceWire Interface

( $V_{DD} = 3.3V \pm 0.3V$ ;  $V_{DDC} = 1.2V \pm 0.1V$ ;  $T_C = -55^{\circ}C$  to  $105^{\circ}C$ )

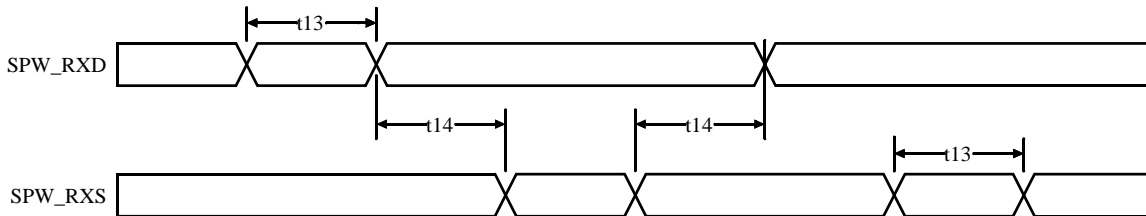
Symbol	Description	Min	Max	Units
$t_{11}^{1,2}$	SPW_CLK period	5	--	ns
$t_{12}^{3,4,5}$	Transmit data and strobe bit width variation (SPW_TXD[3:0] and SPW_TXS[3:0])	UI-600	UI+600	ps
$t_{13}^{5,6}$	Receive data and strobe bit width (SPW_RXD[3:0] and SPW_RXS[3:0])	5	--	ns
$t_{14}^5$	Receive data and strobe edge separation (SPW_RXD[3:0] and SPW_RXS[3:0])	$1/2 * t_{11} + 0.5$	--	ns

**Notes:**

1. The SPW\_CLK frequency must be less than or equal to 10x the SYSCLK frequency. For example, if SPW\_CLK is running at 200MHz, the SYSCLK frequency must be greater than or equal to 20MHz.
2. Functionally tested.
3. Applies to both high pulse and low pulse.
4. A unit interval (UI) is defined as the nominal, or ideal, bit width.
5. Guaranteed by design.
6. The SPW\_CLK period must be less than or equal to the minimum receive data/strobe bit width.



**Figure 8. SpaceWire Transmit Timing Diagram**



**Figure 9. SpaceWire Receive Timing Diagram**

#### 4.6 Timing Characteristics for PCI Interface

( $V_{DD} = 3.3V \pm 0.3V$ ;  $V_{DDC} = 1.2V \pm 0.1V$ ;  $T_C = -55^{\circ}C$  to  $105^{\circ}C$ )

Symbol	Description	Min	Max	Units
t17 <sup>1</sup>	PCI_CLK↑ to output valid (PCI_AD[31:0], PCI_C/BE[3:0], PCI_PAR, $\overline{\text{PCI\_FRAME}}$ , $\overline{\text{PCI\_IRDY}}$ , $\overline{\text{PCI\_TDRY}}$ , $\overline{\text{PCI\_STOP}}$ , $\overline{\text{PCI\_DEVSEL}}$ , $\overline{\text{PCI\_PERR}}$ , $\overline{\text{PCI\_REQ}}$ , and $\overline{\text{PCI\_ARB\_GNT}}[7:0]$ )	2	13	ns
t18 <sup>1,2</sup>	PCI_CLK↑ to output valid from high-z (PCI_AD[31:0], PCI_C/BE[3:0], PCI_PAR, $\overline{\text{PCI\_FRAME}}$ , $\overline{\text{PCI\_IRDY}}$ , $\overline{\text{PCI\_TDRY}}$ , $\overline{\text{PCI\_STOP}}$ , $\overline{\text{PCI\_DEVSEL}}$ , and $\overline{\text{PCI\_PERR}}$	2	13	ns
t19 <sup>1,2</sup>	PCI_CLK↑ to output high-Z (PCI_AD[31:0], PCI_C/BE[3:0], PCI_PAR, $\overline{\text{PCI\_FRAME}}$ , $\overline{\text{PCI\_IRDY}}$ , $\overline{\text{PCI\_TDRY}}$ , $\overline{\text{PCI\_STOP}}$ , $\overline{\text{PCI\_DEVSEL}}$ , and $\overline{\text{PCI\_PERR}}$	--	14	ns
t20 <sup>3</sup>	Setup time to PCI_CLK↑ (PCI_AD[31:0], PCI_C/BE[3:0], PCI_PAR, $\overline{\text{PCI\_FRAME}}$ , $\overline{\text{PCI\_IRDY}}$ , $\overline{\text{PCI\_TDRY}}$ , $\overline{\text{PCI\_STOP}}$ , $\overline{\text{PCI\_DEVSEL}}$ , $\overline{\text{PCI\_PERR}}$ , $\overline{\text{PCI\_IDSEL}}$ , $\overline{\text{PCI\_GNT}}$ , and $\overline{\text{PCI\_ARB\_REQ}}[7:0]$ )	4	--	ns
t21 <sup>3</sup>	Hold time from PCI_CLK↑ (PCI_AD[31:0], PCI_C/BE[3:0], PCI_PAR, $\overline{\text{PCI\_FRAME}}$ , $\overline{\text{PCI\_IRDY}}$ , $\overline{\text{PCI\_TDRY}}$ , $\overline{\text{PCI\_STOP}}$ , $\overline{\text{PCI\_DEVSEL}}$ , $\overline{\text{PCI\_PERR}}$ , $\overline{\text{PCI\_IDSEL}}$ , $\overline{\text{PCI\_GNT}}$ , and $\overline{\text{PCI\_ARB\_REQ}}[7:0]$ )	1	--	ns
t22 <sup>4</sup>	PCI_CLK↑ to $\overline{\text{RESET}}$ deassertion	10	--	PCI Clocks
t23a <sup>4</sup>	PCI_CLK↑ to $\overline{\text{PCI\_RST}}$ deassertion	10	--	PCI Clocks
t23b <sup>4</sup>	$\overline{\text{PCI\_RST}}$ assertion to PCI_CLK idle	10	--	PCI Clocks
t24	$\overline{\text{PCI\_RST}}$ active to output high-Z	--	40	ns

#### Notes:

1. All outputs are measured using the load conditions shown in Figure 15.
2. High-Z defined as +/-300mV change from steady state.
3.  $\overline{\text{PCI\_TRDY}}$ ,  $\overline{\text{PCI\_STOP}}$ , and  $\overline{\text{PCI\_DEVSEL}}$  timing is guaranteed by design when used as inputs.
4. Guaranteed by design.

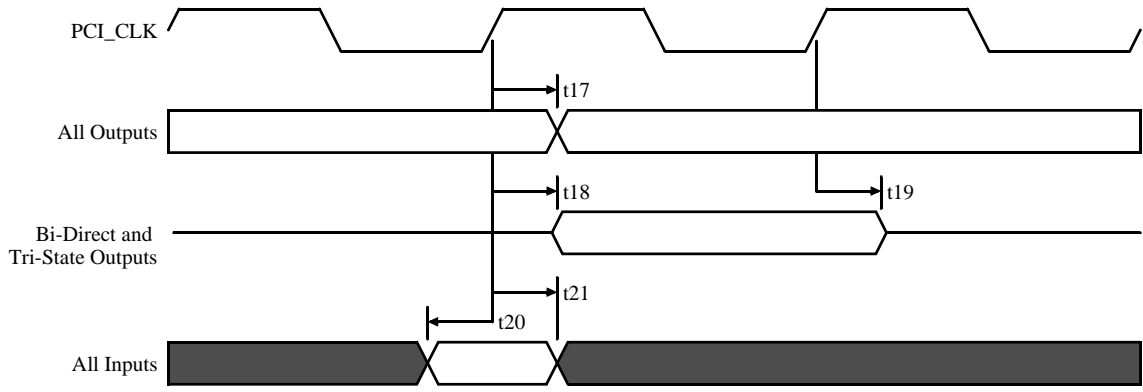


Figure 10. PCI Timing Diagram

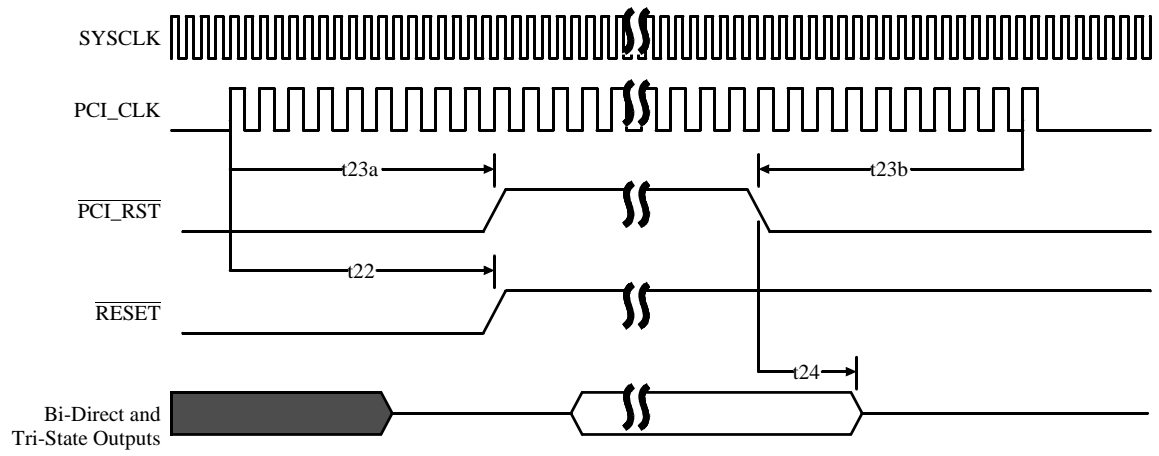


Figure 11. Timing Relationships of Clock and Reset for PCI Core Utilization

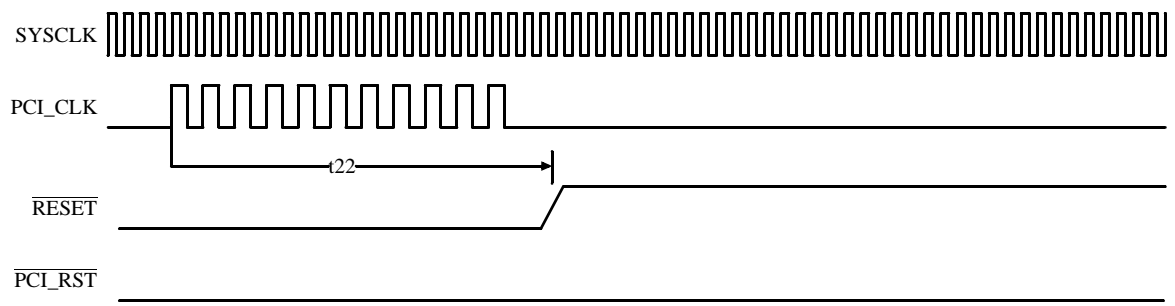


Figure 12. Timing Relationships of Clock and Reset for Unused PCI Core

#### 4.7 Timing Characteristics for Ethernet Interface

( $V_{DD} = 3.3V \pm 0.3V$ ;  $V_{DDC} = 1.2V \pm 0.1V$ ;  $T_C = -55^{\circ}C$  to  $105^{\circ}C$ )

Symbol	Description	Conditions	Min	Max	Units
$t_{25}^1$	ETX_CLK $\uparrow$ to output valid (ETXD[3:0], and ETX_EN)		--	12	ns
$t_{26}^{2,3}$	Setup time to ERX_CLK $\uparrow$ (ERX_DV, ERX_ER, and ERXD[3:0])		1	--	ns
$t_{27}^{2,3}$	Hold time from ERX_CLK $\uparrow$ (ERX_DV, ERX_ER, and ERXD[3:0])		1	--	ns
$t_{28}^1$	EMDC $\uparrow$ to output valid (EMDIO)		$-4+t_{AMBA}^4$	$4+t_{AMBA}^4$	ns
$t_{29}^5$	Setup time to EMDC $\uparrow$ (EMDIO)		10	--	ns
$t_{30}^5$	Hold time from EMDC $\uparrow$ (EMDIO)		10	--	ns

#### Notes:

1. All outputs are measured using the load conditions shown in Figure 17.
2. ERX\_ER timing is guaranteed by design.
3. ERX\_COL and ERX\_CRS are asynchronous inputs and are not tested.
4.  $t_{AMBA}$  is defined as  $t_{SYSCLK}$ .
5. Guaranteed by design.

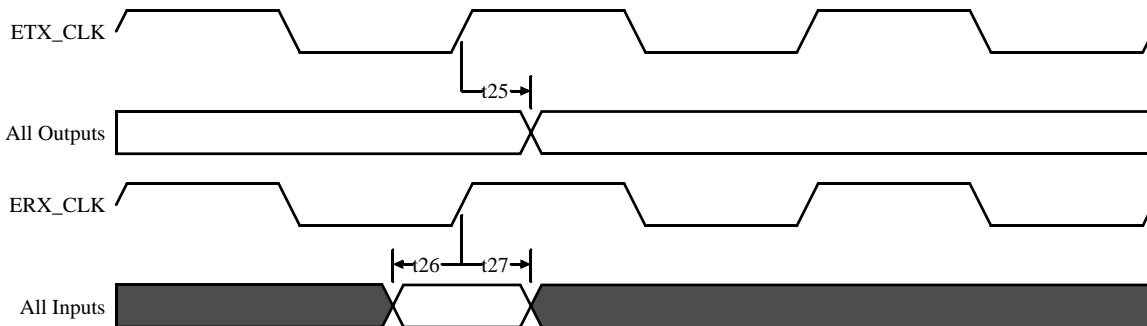


Figure 13. Ethernet Transmit and Receive Timing

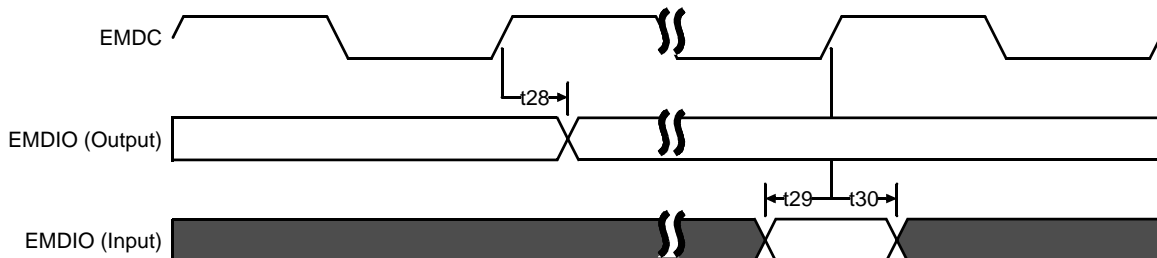


Figure 14. Ethernet MDIO Interface Timing

4.8 Test Conditions for Timing Specifications

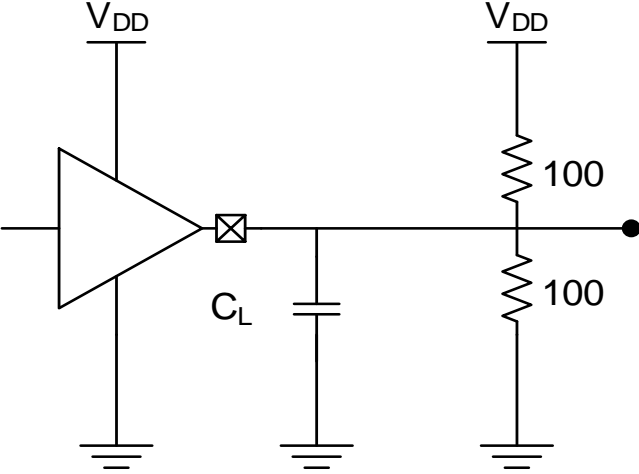


Figure 15. Equivalent Load Circuit for Timing Characteristics Tests  
 $C_L = 50$  pF for ATE test load  
 $C_L = 15$  pF for benchtop test load

## 5.0 Operational Environment

The UT699E processor includes the following SEU mitigation features:

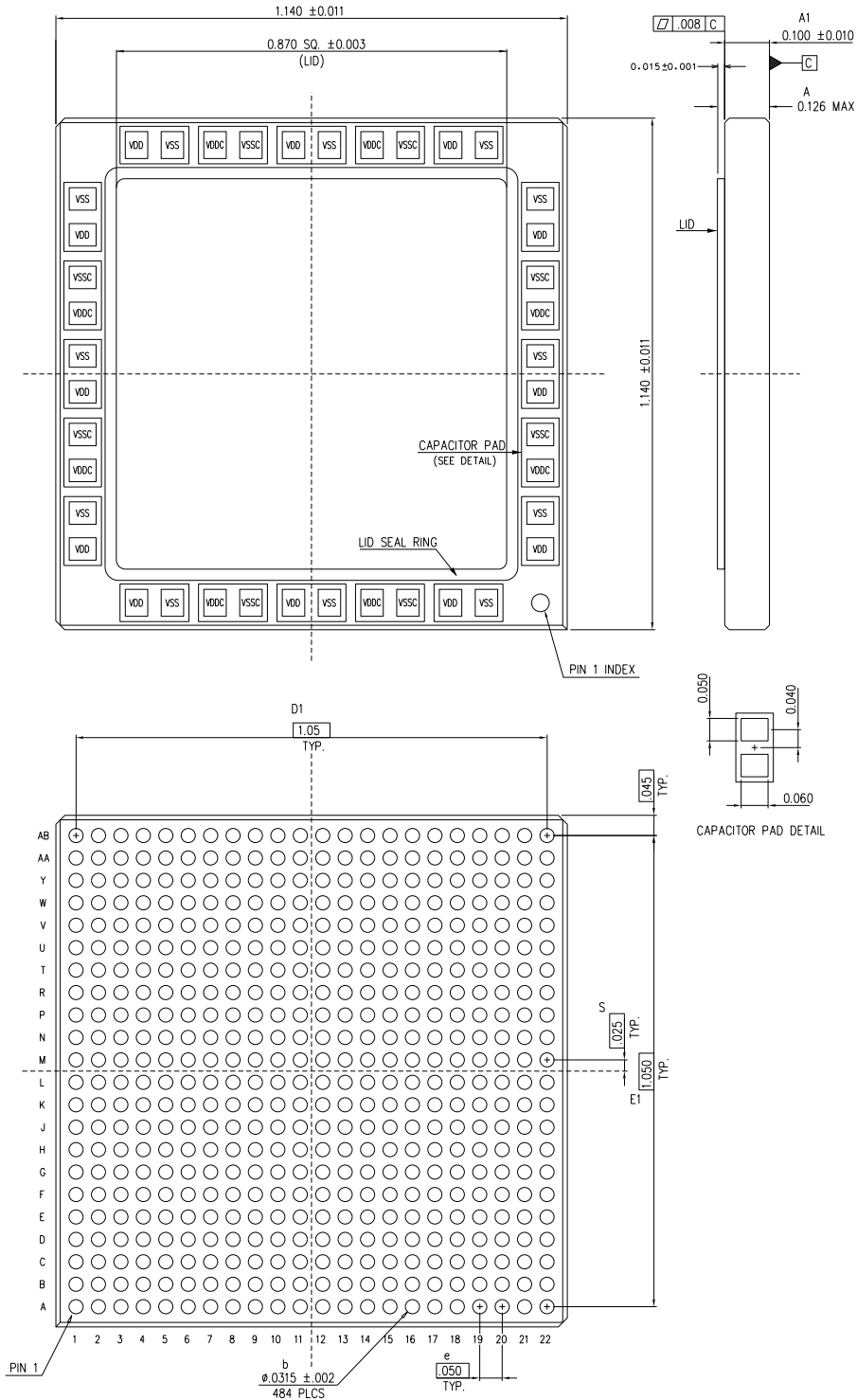
- \* Cache memory error-detection of up to 4 errors per tag or 32-bit word
- \* Autonomous and software transparent error handling
- \* No timing impact due to error detection or correction.

<b>Table 1. Operational Environment</b>		
<b>Parameter</b>	<b>Limit</b>	<b>Units</b>
Total Ionizing Dose (TID)	1E5	rads(Si)
Single Event Latchup (SEL) <sup>1, 2</sup>	>100	MeV-cm <sup>2</sup> /mg
Neutron Fluence	1.0E14	n/cm <sup>2</sup>

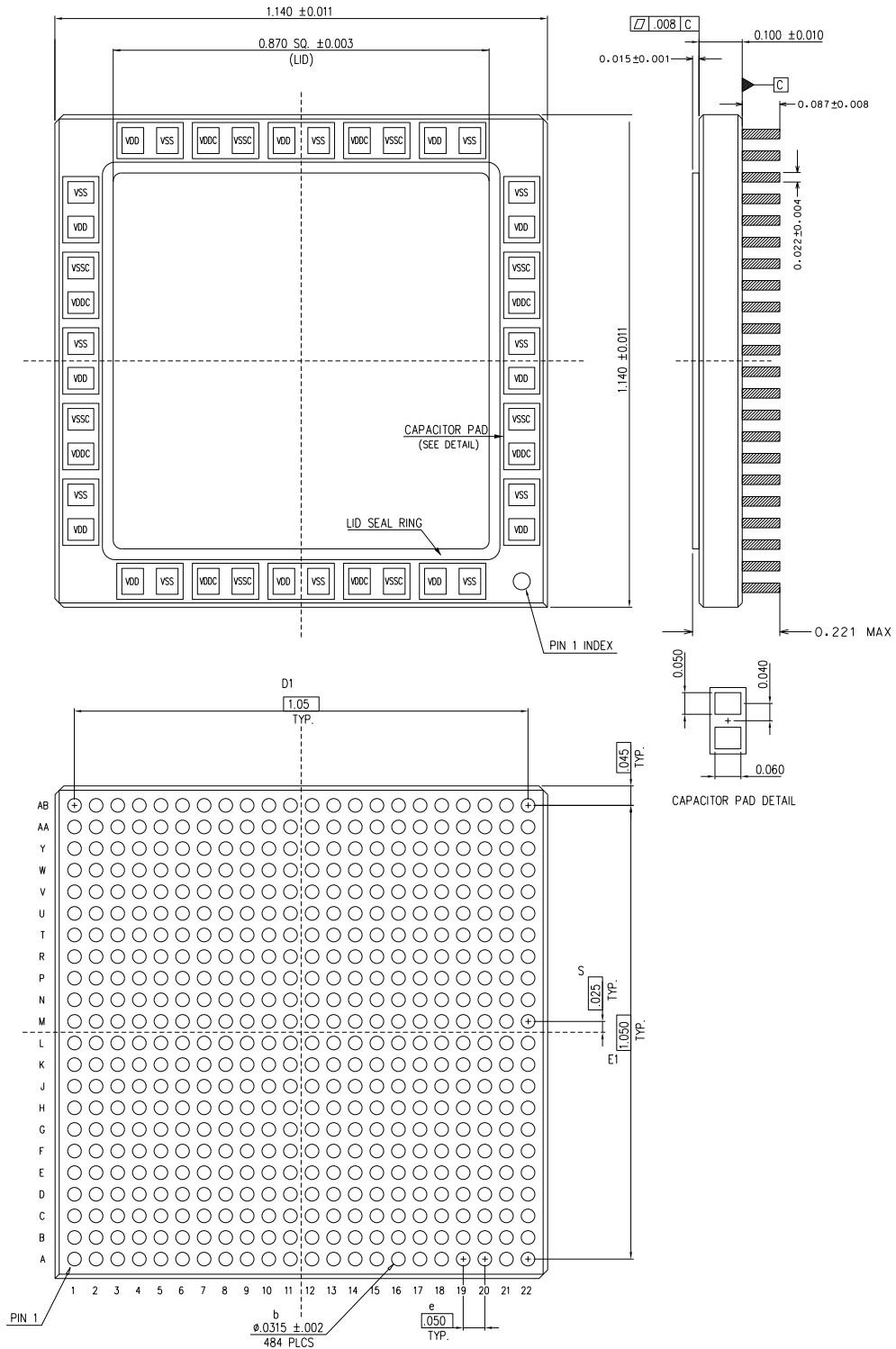
**Notes:**

1. The UT699E is latchup immune to particle LETs >100 MeV-cm<sup>2</sup>/mg.
2. Worst case temperature and voltage of T<sub>C</sub> = +105°C, V<sub>DD</sub> = 3.6V, V<sub>DDC</sub> = 1.3V.
3. Contact factory for error rate information.

# 6.0 Packaging

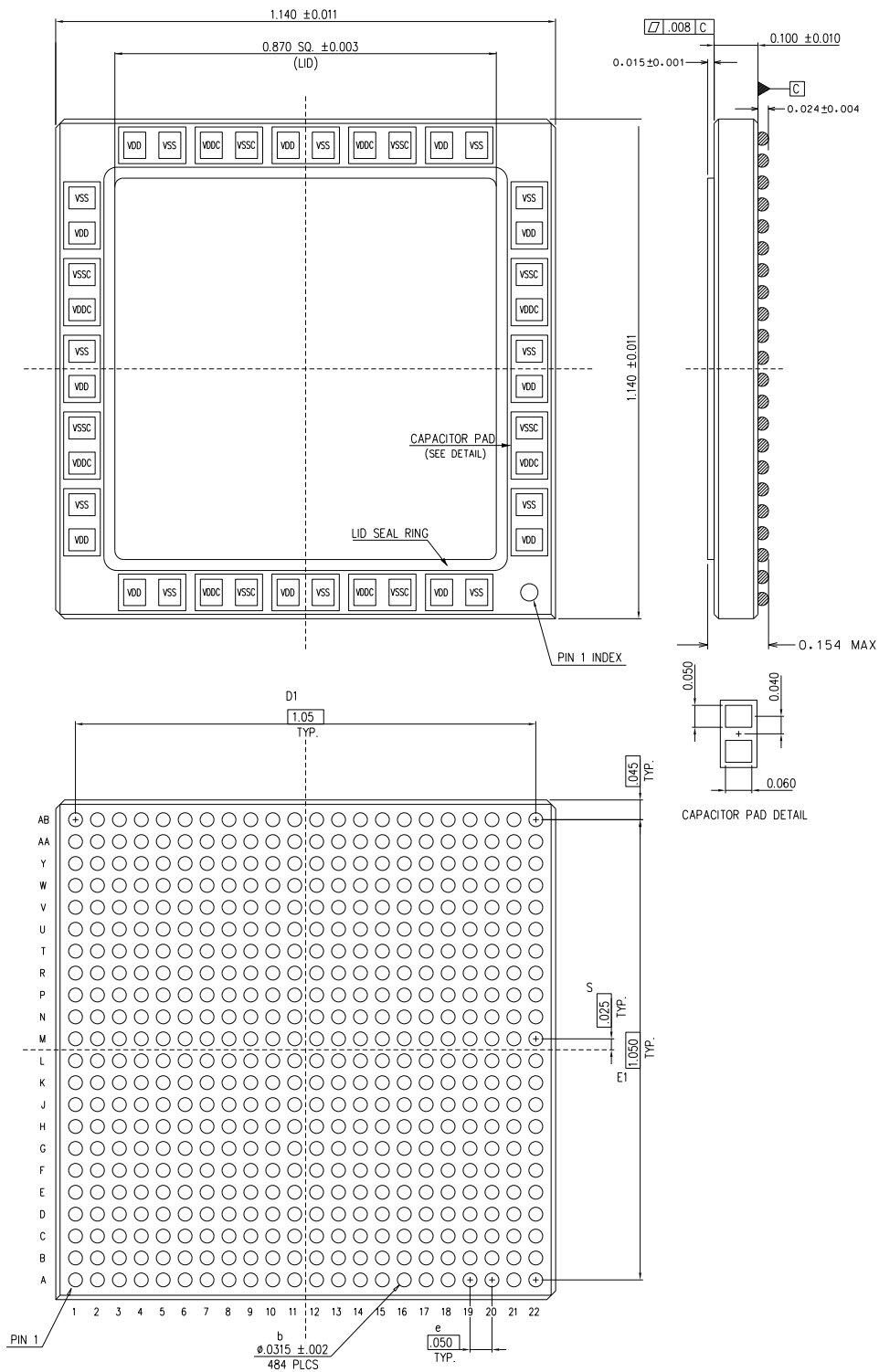


**Figure 16. 484-lead Ceramic Land Grid Array**



- NOTES:  
 1. SEAL RING IS CONNECTED TO VSS.  
 2. UNITS ARE IN INCHES.

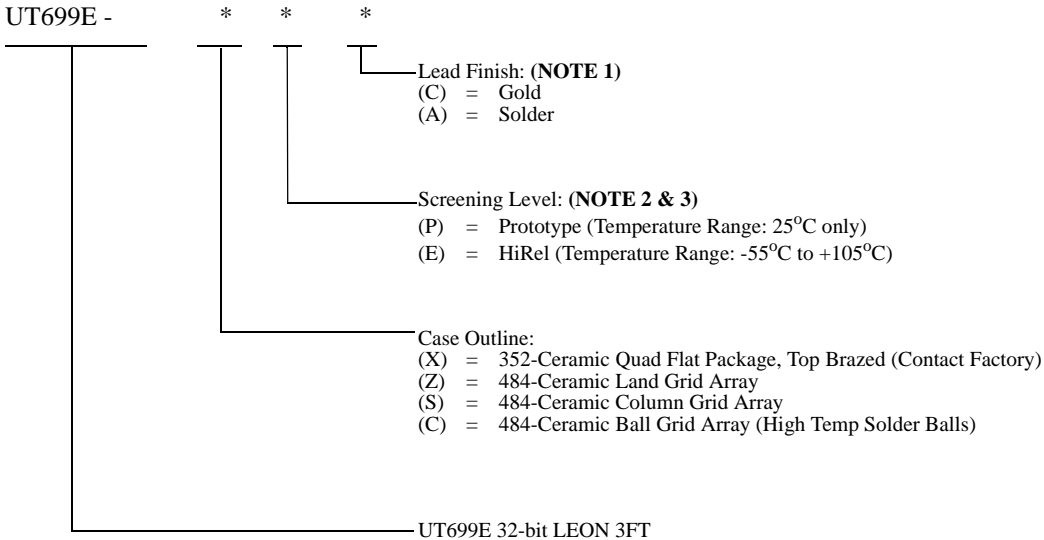
**Figure 17. 484-lead Ceramic Column Grid Array**



**Figure 18. 484-lead Ceramic Ball Grid Array**

# 7.0 Ordering Information

## UT699E LEON 3FT

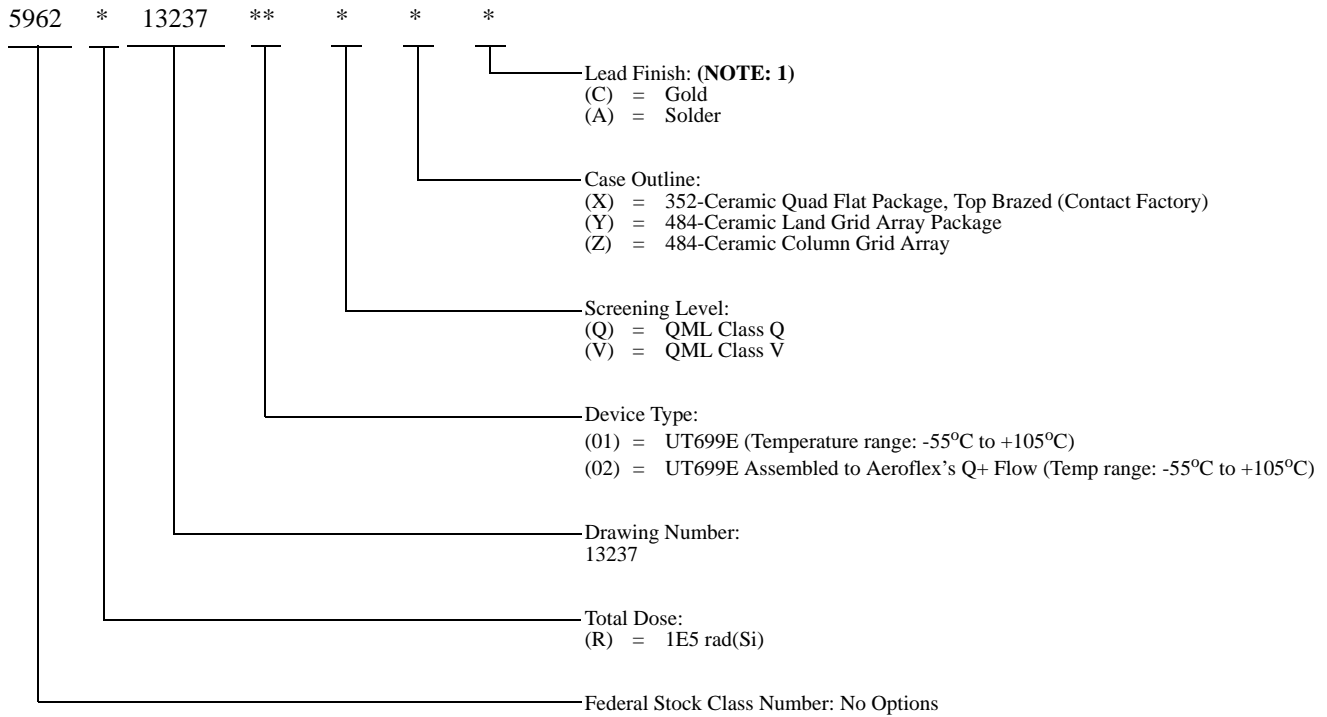


**Notes:**

1. Lead finish (A or C) must be specified.
2. Prototype Flow per Aeroflex Manufacturing Flows Document. Devices are tested at 25°C only. Radiation is neither tested nor guaranteed.
3. HiRel Flow per Aeroflex Manufacturing Flows Document. Radiation is neither tested nor guaranteed.

Package Option	Associated Lead Finish
(X) 352-CQFP	(C) Gold
(Z) 484-CLGA	(C) Gold
(S) 484-CCGA	(A) Solder
(C) 484-CBGA	(A) Solder

**UT699E LEON 3FT: SMD**



Notes:

1. Lead finish is "C" (gold) only for case outlines "X" and "Y". Lead finish is "A" (solder) only for case outline "Z".

Package Option	Associated Lead Finish
(X) 352-CQFP	(C) Gold
(Y) 484-CLGA	(C) Gold
(Z) 484-CCGA	(A) Solder

# *Aeroflex Colorado Springs - Datasheet Definition*

**Advanced Datasheet - Product In Development**

**Preliminary Datasheet - Shipping Prototype**

**Datasheet - Shipping QML & Reduced Hi-Rel**

*www.aeroflex.com    info-ams@aeroflex.com*



Aeroflex Colorado Springs, Inc., reserves the right to make changes to any products and services herein at any time without notice. Consult Aeroflex or an authorized sales representative to verify that the information in this data sheet is current before using this product. Aeroflex does not assume any responsibility or liability arising out of the application or use of any product or service described herein, except as expressly agreed to in writing by Aeroflex; nor does the purchase, lease, or use of a product or service from Aeroflex convey a license under any patent rights, copyrights, trademark rights, or any other of the intellectual rights of Aeroflex or of third parties.



Our passion for performance is defined by three attributes represented by these three icons: solution-minded, performance-driven and customer-focused

**DATA SHEET REVISION HISTORY**

<b>Revision Date</b>	<b>Description of Change</b>	<b>Page(s)</b>	<b>Author</b>
11/13	Release of Preliminary Data Sheet	All	JN
2/14/14	Replaced package drawings	As noted	JN
3/12/14	Replaced BGA package drawing	As noted	JN