

SCAN182373A

Transparent Latch with 25Ω Series Resistor Outputs

General Description

The SCAN182373A is a high performance BiCMOS transparent latch featuring separate data inputs organized into dual 9-bit bytes with byte-oriented latch enable and output enable control signals. This device is compliant with IEEE 1149.1 Standard Test Access Port and Boundary-Scan Architecture with the incorporation of the defined boundary-scan test logic and test access port consisting of Test Data Input (TDI), Test Data Out (TDO), Test Mode Select (TMS), and Test Clock (TCK).

Features

- IEEE 1149.1 (JTAG) Compliant
- High performance BiCMOS technology
- 25Ω series resistor outputs eliminate need for external terminating resistors
- Buffered active-low latch enable
- TRI-STATE® outputs for bus-oriented applications
- 25 mil pitch SSOP (Shrink Small Outline Package)
- Includes CLAMP, IDCODE and HIGHZ instructions
- Additional instructions SAMPLE-IN, SAMPLE-OUT and EXTEST-OUT
- Power up TRI-STATE for hot insert
- Member of National's SCAN Products

Ordering Code: See Section 11

Connection Diagram

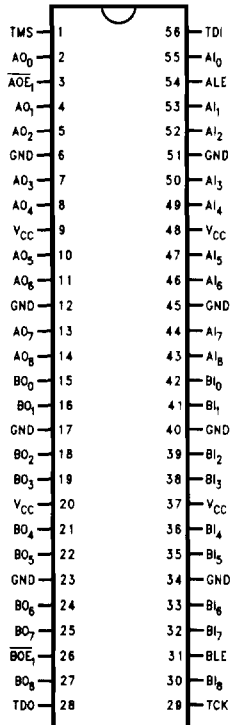

Pin Names	Description
A ₀ (0-8), B ₀ (0-8)	Data Inputs
ALE, BLE	Latch Enable Inputs
AOE ₁ , BOE ₁	TRI-STATE Output Enable Inputs
AO ₀ (0-8), BO ₀ (0-8)	TRI-STATE Latch Outputs

Order Number	Description
SCAN182373ASSC	SSOP in Tubes
SCAN182373ASSCX	SSOP in Tape and Reel
SCAN182373AFMQB	Military Flatpak

TL/F/11544-1

Truth Table

Inputs			AO (0-8)
ALE	$\dagger\overline{AOE_1}$	AI (0-8)	
X	H	X	Z
H	L	L	L
H	L	H	H
L	L	X	AO ₀

Inputs			BO (0-8)
BLE	$\dagger\overline{BOE_1}$	BI (0-8)	
X	H	X	Z
H	L	L	L
H	L	H	H
L	L	X	BO ₀

H = HIGH Voltage Level
 L = LOW Voltage Level
 X = Immaterial
 Z = High Impedance
 AO₀ = Previous AO before H-to-L transition of ALE
 BO₀ = Previous BO before H-to-L transition of BLE
 † = Inactive-to-active transition must occur to enable outputs upon power-up.

Functional Description

The SCAN182373A consists of two sets of nine D-type latches with TRI-STATE standard outputs. When the Latch Enable (ALE or BLE) input is HIGH, data on the inputs (AI₍₀₋₈₎ or BI₍₀₋₈₎) enters the latches. In this condition the latches are transparent, i.e., a latch output will change state each time its input changes. When Latch Enable is LOW, the latches store the information that was present on the inputs a set-up time preceding the HIGH-to-LOW transition of the Latch Enable. The TRI-STATE standard outputs are controlled by the Output Enable ($\overline{AOE_1}$ or $\overline{BOE_1}$) input. When Output Enable is LOW, the standard outputs are in the 2-state mode. When Output Enable is HIGH, the standard outputs are in the high impedance mode, but this does not interfere with entering new data into the latches.

Logic Diagram

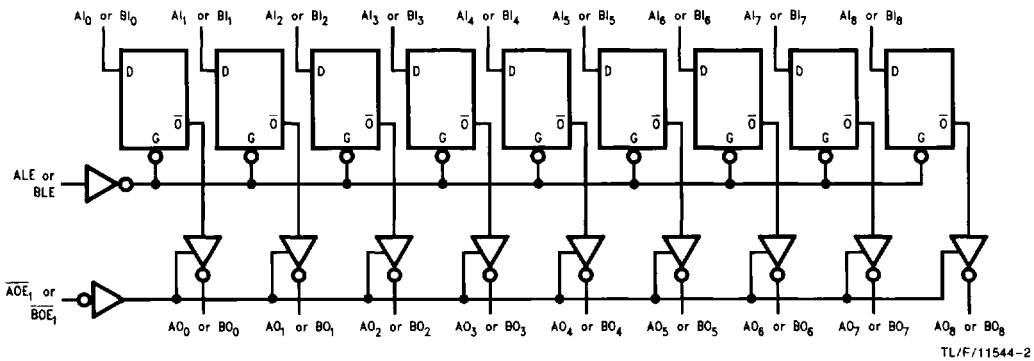

Please note that this diagram is provided only for the understanding of logic operations and should not be used to estimate propagation delays.

Block Diagrams

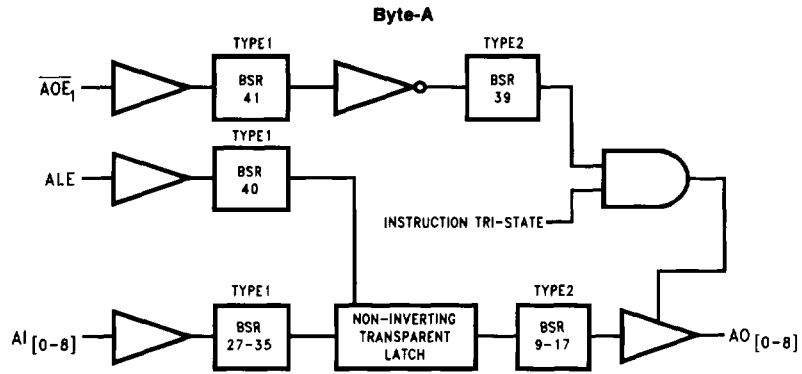

TL/F/11544-3

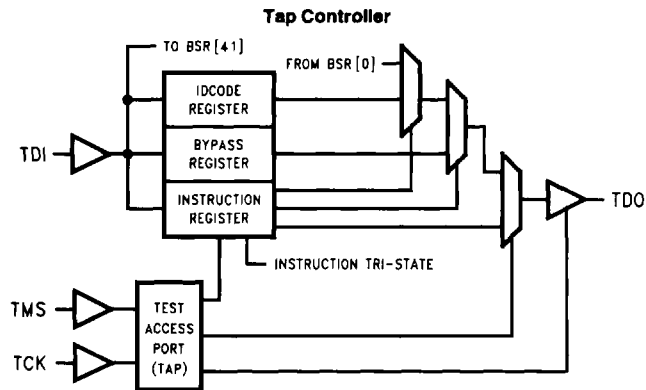

TL/F/11544-4

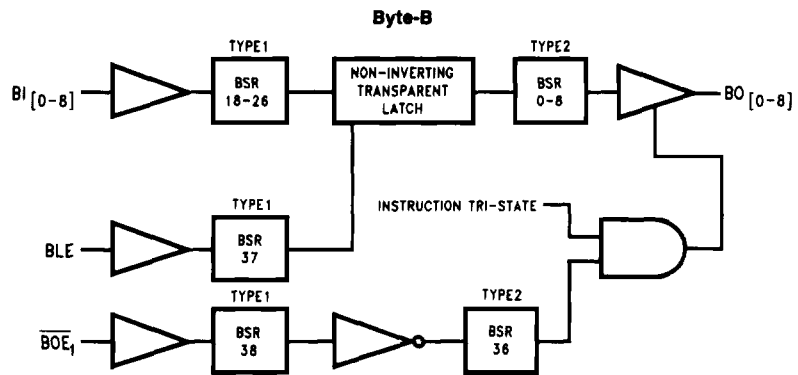

TL/F/11544-5

Note: BSR stands for Boundary Scan Register.

Description of BOUNDARY-SCAN Circuitry

The scan cells used in the BOUNDARY-SCAN register are one of the following two types depending upon their location. Scan cell TYPE1 is intended to solely observe system data, while TYPE2 has the additional ability to control system data. (See IEEE Standard 1149.1 *Figure 10-11* for a further description of scan cell TYPE 1 and *Figure 10-12* for a further description of scan cell TYPE 2.)

Scan cell TYPE 1 is located on each system input pin while scan cell TYPE2 is located at each system output pin as well as at each of the two internal active-high output enable signals. AOE controls the activity of the A-outputs while BOE controls the activity of the B-outputs. Each will activate their respective outputs by loading a logic high.

The BYPASS register is a single bit shift register stage identical to scan cell TYPE1. It captures a fixed logic low.

Bypass Register Scan Chain Definition Logic 0

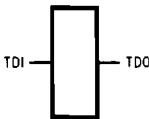

TL/F/11544-19

SCAN182373A Product IDCODE (32-Bit Code per IEEE 1149.1)

Version	Entity	Part Number	Manufacturer ID	Required by 1149.1
0000	111111	0000001000	00000001111	1

MSB

LSB

The INSTRUCTION register is an 8-bit register which captures the default value of 10000001 (SAMPLE/PRELOAD) during the CAPTURE-IR instruction command. The benefit of capturing SAMPLE/PRELOAD as the default instruction during CAPTURE-IR is that the user is no longer required to shift in the 8-bit instruction for SAMPLE/PRELOAD. The sequence of: CAPTURE-IR → EXIT1-IR → UPDATE-IR will update the SAMPLE/PRELOAD instruction. For more information refer to the section on instruction definitions.

Instruction Register Scan Chain Definition

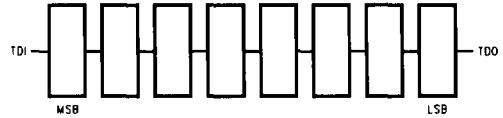

TL/F/11544-20

MSB → LSB

Instruction Code	Instruction
00000000	EXTEST
10000001	SAMPLE/PRELOAD
10000010	CLAMP
00000011	HIGH-Z
01000001	SAMPLE-IN
01000010	SAMPLE-OUT
00100010	EXTEST-OUT
10101010	IDCODE
11111111	BYPASS
All Others	BYPASS

Description of BOUNDARY-SCAN Circuitry (Continued)

Scan Cell TYPE1

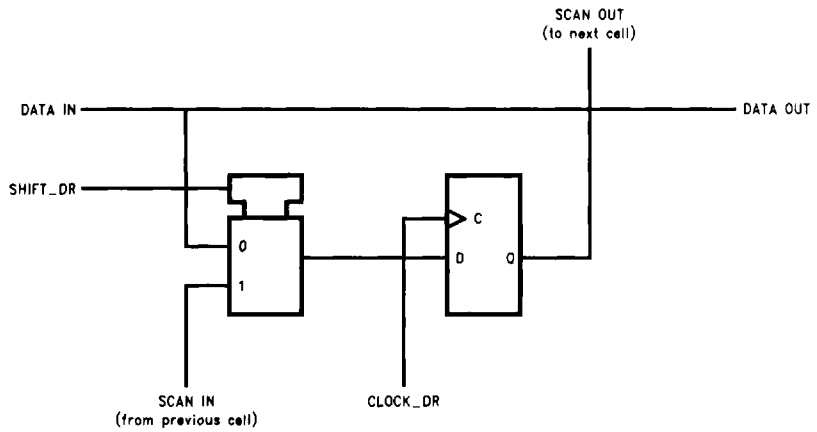

TL/F/11544-21

Scan Cell TYPE2

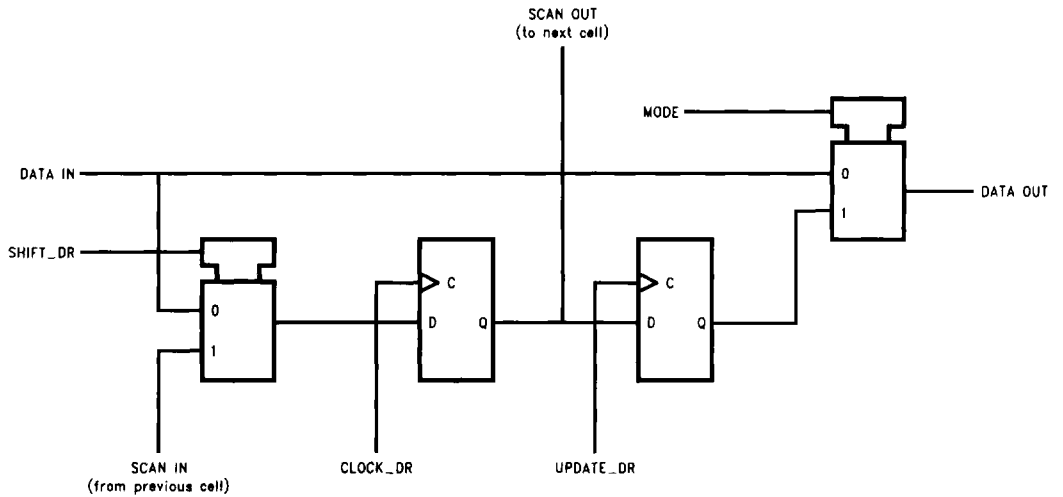

TL/F/11544-22

Description of BOUNDARY-SCAN Circuitry (Continued)

BOUNDARY-SCAN Register
Scan Chain Definition (42 Bits in Length)

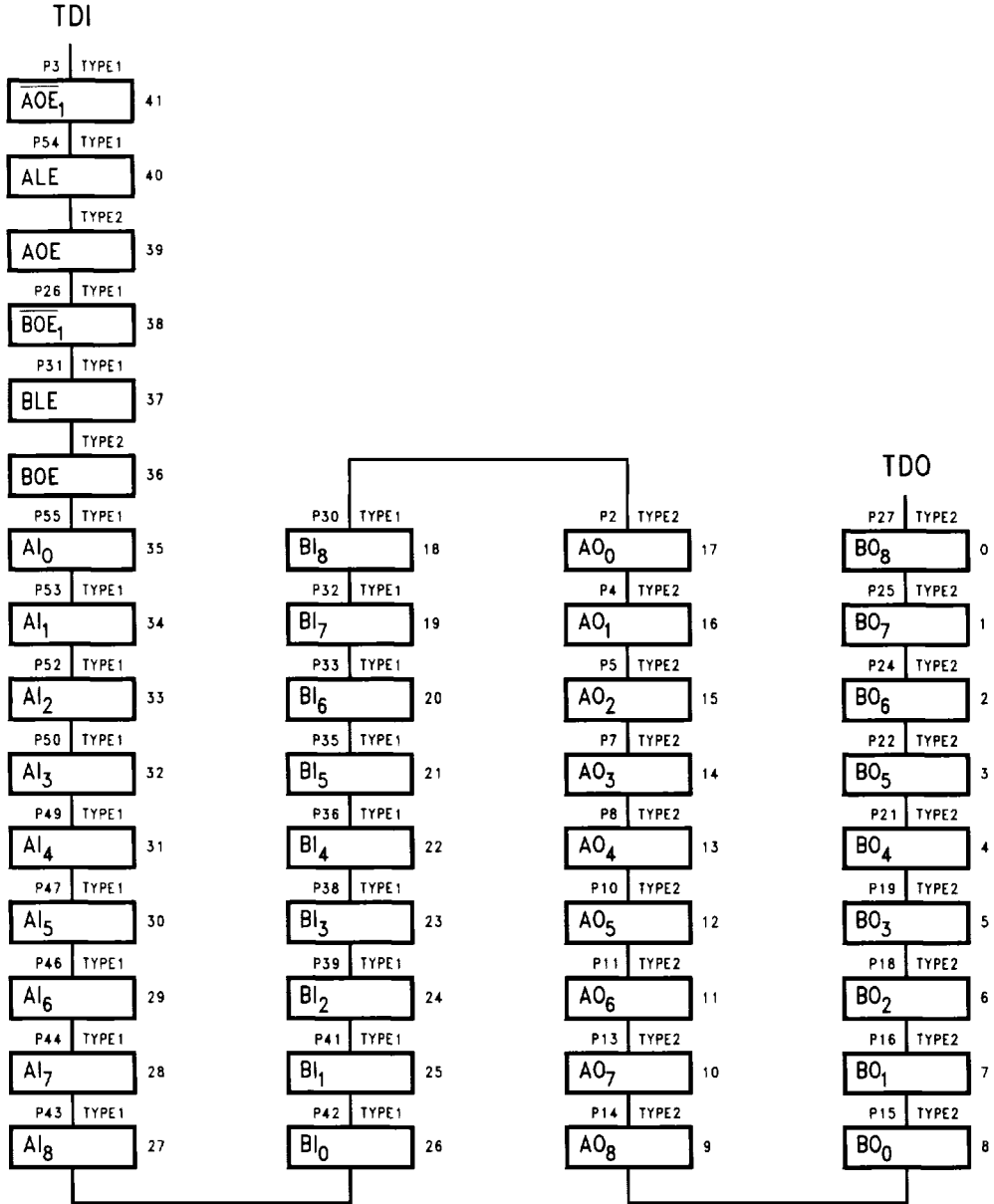

TL/F/11544-23

Description of BOUNDARY-SCAN Circuitry (Continued)

**Input BOUNDARY-SCAN Register
Scan Chain Definition (22 Bits in Length)
When Sample In Is Active**

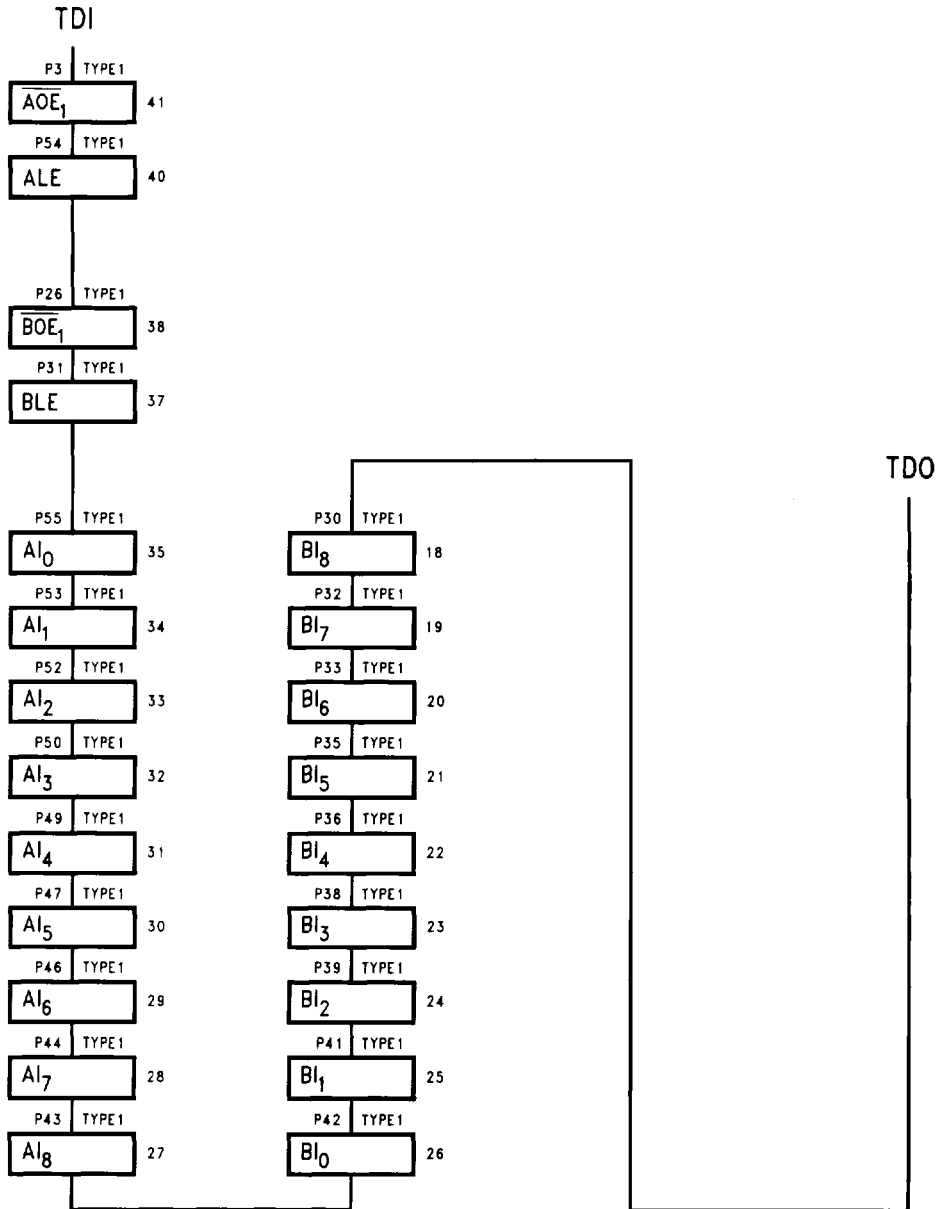

Description of BOUNDARY-SCAN Circuitry (Continued)

182373A

Output BOUNDARY-SCAN Register Scan Chain Definition (20 Bits in Length) When Sample Out and Extest Out are Active

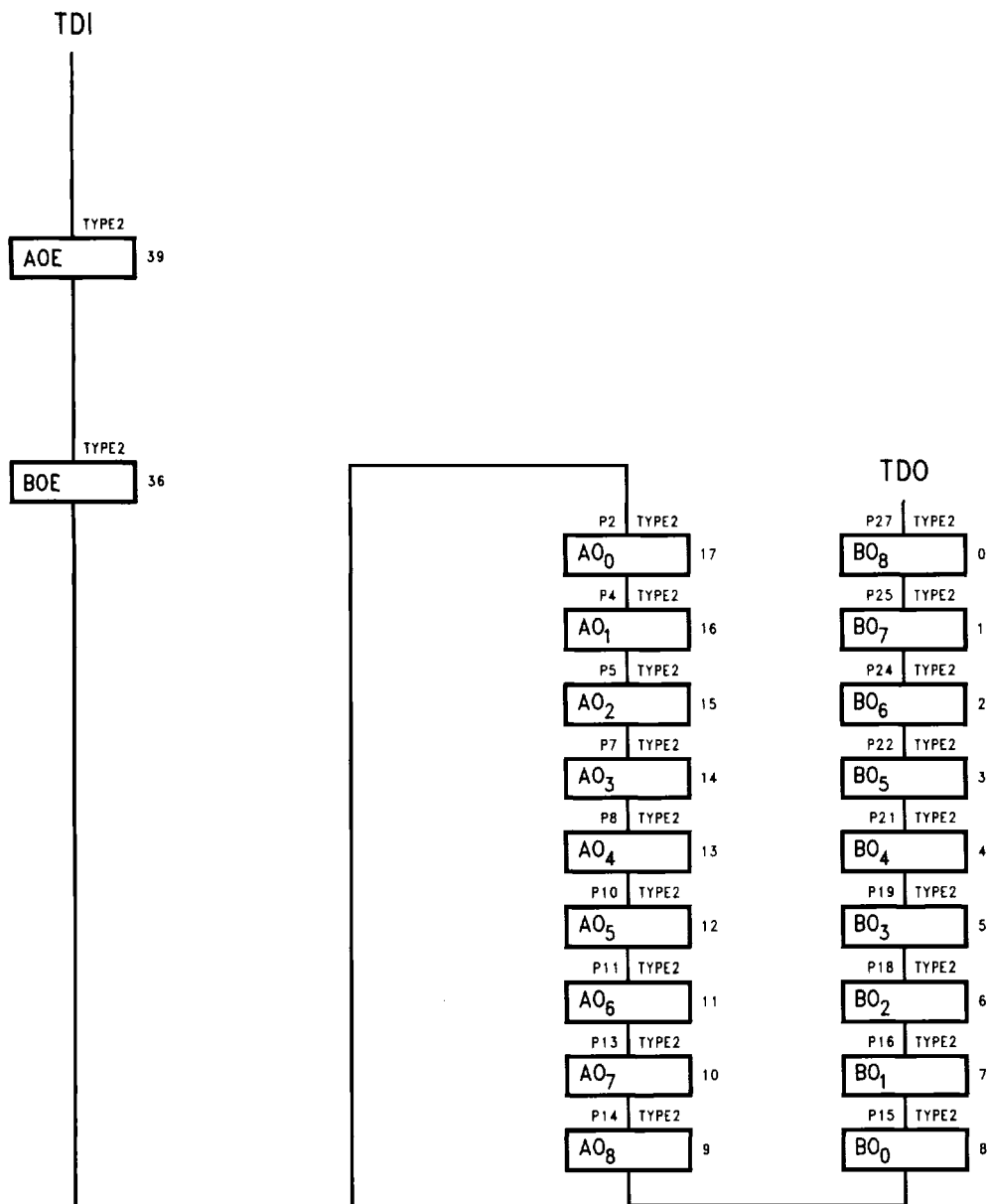

Description of BOUNDARY-SCAN Circuitry (Continued)

BOUNDARY-SCAN Register Definition Index

Bit No.	Pin Name	Pin No.	Pin Type	Scan Cell Type	
41	\overline{AOE}_1	3	Input	TYPE1	Control Signals
40	ALE	54	Input	TYPE1	
39	AOE		Internal	TYPE2	
38	\overline{BOE}_1	26	Input	TYPE1	
37	BLE	31	Input	TYPE1	
36	BOE		Internal	TYPE2	
35	Al ₀	55	Input	TYPE1	A-in
34	Al ₁	53	Input	TYPE1	
33	Al ₂	52	Input	TYPE1	
32	Al ₃	50	Input	TYPE1	
31	Al ₄	49	Input	TYPE1	
30	Al ₅	47	Input	TYPE1	
29	Al ₆	46	Input	TYPE1	
28	Al ₇	44	Input	TYPE1	
27	Al ₈	43	Input	TYPE1	
26	Bl ₀	42	Input	TYPE1	B-in
25	Bl ₁	41	Input	TYPE1	
24	Bl ₂	39	Input	TYPE1	
23	Bl ₃	38	Input	TYPE1	
22	Bl ₄	36	Input	TYPE1	
21	Bl ₅	35	Input	TYPE1	
20	Bl ₆	33	Input	TYPE1	
19	Bl ₇	32	Input	TYPE1	
18	Bl ₈	30	Input	TYPE1	
17	AO ₀	2	Output	TYPE2	A-out
16	AO ₁	4	Output	TYPE2	
15	AO ₂	5	Output	TYPE2	
14	AO ₃	7	Output	TYPE2	
13	AO ₄	8	Output	TYPE2	
12	AO ₅	10	Output	TYPE2	
11	AO ₆	11	Output	TYPE2	
10	AO ₇	13	Output	TYPE2	
9	AO ₈	14	Output	TYPE2	
8	BO ₀	15	Output	TYPE2	B-out
7	BO ₁	16	Output	TYPE2	
6	BO ₂	18	Output	TYPE2	
5	BO ₃	19	Output	TYPE2	
4	BO ₄	21	Output	TYPE2	
3	BO ₅	22	Output	TYPE2	
2	BO ₆	24	Output	TYPE2	
1	BO ₇	25	Output	TYPE2	
0	BO ₈	27	Output	TYPE2	

Absolute Maximum Ratings (Note 1)

If Military/Aerospace specified devices are required, please contact the National Semiconductor Sales Office/Distributors for availability and specifications.

Storage Temperature	-65°C to +150°C
Ambient Temperature under Bias	-55°C to +125°C
Junction Temperature under Bias	
Ceramic	-55°C to +175°C
Plastic	-55°C to +150°C
V _{CC} Pin Potential to Ground Pin	-0.5V to +7.0V
Input Voltage (Note 2)	-0.5V to +7.0V
Input Current (Note 2)	-30 mA to +5.0 mA
Voltage Applied to Any Output in the Disabled or Power-Off State in the HIGH State	-0.5V to +5.5V -0.5V to V _{CC}
Current Applied to Output in LOW State (Max)	Twice the Rated I _{OL} (mA)
DC Latchup Source Current	
Commercial	-500 mA
Military	-300 mA

Over Voltage Latchup (I/O)	10V
ESD (HBM) Min	2000V

Note 1: Absolute maximum ratings are values beyond which the device may be damaged or have its useful life impaired. Functional operation under these conditions is not implied.

Note 2: Either voltage limit or current limit is sufficient to protect inputs.

Recommended Operating Conditions

Free Air Ambient Temperature	
Military	-55°C to +125°C
Commercial	-40°C to +85°C
Supply Voltage	
Military	+4.5V to +5.5V
Commercial	+4.5V to +5.5V
Minimum Input Edge Rate	($\Delta V/\Delta t$)
Data Input	50 mV/ns
Enable Input	20 mV/ns

DC Electrical Characteristics

Symbol	Parameter	V _{CC}	Min	Typ	Max	Units	Conditions
V _{IH}	Input HIGH Voltage		2.0			V	Recognized HIGH Signal
V _{IL}	Input LOW Voltage				0.8	V	Recognized LOW Signal
V _{CD}	Input Clamp Diode Voltage	Min			-1.2	V	I _{IN} = -18 mA
V _{OH}	Output HIGH Voltage	Mil	Min	2.5		V	I _{OH} = -3 mA
		Comm	Min	2.0		V	I _{OH} = -24 mA
		Comm	Min	2.0		V	I _{OH} = -32 mA
V _{OL}	Output LOW Voltage	Mil	Min		0.8	V	I _{OL} = 12 mA
		Comm	Min		0.8	V	I _{OL} = 15 mA
I _{IH}	Input HIGH Current	All Others	Max		5	μA	V _{IN} = 2.7V (Note 1)
			Max		5	μA	V _{IN} = V _{CC}
		TMS, TDI	Max		5	μA	V _{IN} = V _{CC}
I _{BVI}	Input HIGH Current Breakdown Test	Max			7	μA	V _{IN} = 7.0V
I _{BVIT}	Input HIGH Current Breakdown Test (I/O)	Max			100	μA	V _{IN} = 5.5V
I _{IL}	Input LOW Current	All Others	Max		-5	μA	V _{IN} = 0.5V (Note 1)
			Max		-5	μA	V _{IN} = 0.0V
		TMS, TDI	Max		-385	μA	V _{IN} = 0.0V
V _{ID}	Input Leakage Test	0.0	4.75			V	I _{ID} = 1.9 μA All Other Pins Grounded
I _{IH} + I _{OZH}	Output Leakage Current	Max			50	μA	V _{OUT} = 2.7V
I _{IL} + I _{OZL}	Output Leakage Current	Max			-50		V _{OUT} = 0.5V
I _{OZH}	Output Leakage Current	Max			50	μA	V _{OUT} = 2.7V
I _{OZL}	Output Leakage Current	Max			-50	μA	V _{OUT} = 0.5V
I _{OS}	Output Short-Circuit Current	Max	-100		-275	mA	V _{OUT} = 0.0V

Note 1: Guaranteed not tested.

DC Electrical Characteristics (Continued)

Symbol	Parameter	V _{CC}	Min	Typ	Max	Units	Conditions	
I _{CEX}	Output HIGH Leakage Current	Max			50	μA	V _{OUT} = V _{CC}	
I _{ZZ}	Bus Drainage Test	0.0			100	μA	V _{OUT} = 5.5V All Others Grounded	
I _{CCH}	Power Supply Current	Max			250	μA	V _{OUT} = V _{CC} ; TDI, TMS = V _{CC}	
		Max			1.0	mA	V _{OUT} = V _{CC} ; TDI, TMS = GND	
I _{CCL}	Power Supply Current	Max			65	mA	V _{OUT} = LOW; TDI, TMS = V _{CC}	
		Max			65.8	mA	V _{OUT} = LOW; TDI, TMS = GND	
I _{CCZ}	Power Supply Current	Max			250	μA	TDI, TMS = V _{CC}	
		Max			1.0	mA	TDI, TMS = GND	
I _{CC1}	Additional I _{CC} /Input		All Other Inputs	Max		2.9	mA	V _{IN} = V _{CC} - 2.1V
			TDI, TMS Inputs	Max		3	mA	V _{IN} = V _{CC} - 2.1V
I _{CCD}	Dynamic I _{CC}	No Load	Max		0.2	mA/ MHz	Outputs Open One Bit Toggling, 50% Duty Cycle	

Note 1: Guaranteed not tested.

AC Electrical Characteristics Normal Operation: See Section 4

Symbol	Parameter	V _{CC} [*] (V)	Military			Commercial			Units	Fig. No.
			T _A = -55°C to +125°C C _L = 50 pF			T _A = -40°C to +85°C C _L = 50 pF				
			Min	Typ	Max	Min	Typ	Max		
t _{PLH} t _{PHL}	Propagation Delay D to Q	5.0				1.2 2.0	3.7 4.5	6.5 7.4	ns	4-1, 2
t _{PLH} t _{PHL}	Propagation Delay LE to Q	5.0				1.3 1.8	4.1 4.5	7.4 7.3	ns	4-1, 2
t _{PLZ} t _{PHZ}	Disable Time	5.0				1.6 1.8	4.9 6.0	9.0 10.7	ns	4-3, 4
t _{PZL} t _{PZH}	Enable Time	5.0				1.6 1.0	6.0 5.0	9.5 9.3	ns	4-3, 4

*Voltage Range 5.0V ±0.5V

AC Operating Requirements Normal Operation: See Section 4

Symbol	Parameter	V _{CC} [*] (V)	Military			Commercial			Units	Fig. No.
			T _A = -55°C to +125°C C _L = 50 pF			T _A = -40°C to +85°C C _L = 50 pF				
			Guaranteed Minimum							
t _S	Setup Time, H or L Data to LE	5.0					1.7	ns	4-5	
t _H	Hold Time, H or L LE to Data	5.0					1.6	ns	4-5	
t _W	LE Pulse Width	5.0					2.3	ns	4-2	

*Voltage Range 5.0V ±0.5V

AC Electrical Characteristics Scan Test Operation: See Section 4

Symbol	Parameter	V _{CC} * (V)	Military			Commercial			Units	Fig. No.
			T _A = -55°C to +125°C C _L = 50 pF			T _A = -40°C to +85°C C _L = 50 pF				
			Min	Typ	Max	Min	Typ	Max		
t _{PLH} t _{PHL}	Propagation Delay TCK to TDO	5.0				3.6 4.8	5.8 7.4	8.6 10.6	ns	4-8
t _{PLZ} t _{PHZ}	Disable Time TCK to TDO	5.0				2.7 4.0	5.6 7.1	9.0 10.9	ns	4-9, 10
t _{PZL} t _{PZH}	Enable Time TCK to TDO	5.0				5.2 3.6	8.6 6.6	12.5 10.1	ns	4-9, 10
t _{PLH} t _{PHL}	Propagation Delay TCK to Data Out during Update-DR State	5.0				3.9 5.1	6.4 8.0	9.5 11.6	ns	4-8
t _{PLH} t _{PHL}	Propagation Delay TCK to Data Out during Update-IR State	5.0				4.7 5.7	7.7 9.1	11.3 13.1	ns	4-8
t _{PLH} t _{PHL}	Propagation Delay TCK to Data Out during Test Logic Reset State	5.0				5.5 6.7	9.2 10.7	13.6 15.6	ns	4-8
t _{PLZ} t _{PHZ}	Disable Time TCK to Data Out during Update-DR State	5.0				4.1 4.7	7.7 8.4	12.1 12.7	ns	4-9, 10
t _{PLZ} t _{PHZ}	Disable Time TCK to Data Out during Update-IR State	5.0				4.2 4.7	8.3 9.0	13.5 14.0	ns	4-9, 10
t _{PLZ} t _{PHZ}	Disable Time TCK to Data Out during Test Logic Reset State	5.0				5.5 6.3	10.1 10.8	15.6 16.2	ns	4-9, 10
t _{PZL} t _{PZH}	Enable Time TCK to Data Out during Update-DR State	5.0				5.8 4.3	9.6 7.7	14.2 11.7	ns	4-9, 10
t _{PZL} t _{PZH}	Enable Time TCK to Data Out during Update-IR State	5.0				6.1 4.7	11.0 9.0	16.0 13.7	ns	4-9, 10
t _{PZL} t _{PZH}	Enable Time TCK to Data Out during Test Logic Reset State	5.0				7.3 5.8	12.5 10.5	18.3 15.8	ns	4-9, 10

*Voltage Range 5.0V ±0.5V

AC Operating Requirements

Scan Test Operation: See Section 4

Symbol	Parameter	V _{CC} * (V)	Military	Commercial	Units	Fig. No.
			T _A = -55°C to +125°C C _L = 50 pF	T _A = -40°C to +85°C C _L = 50 pF		
			Guaranteed Minimum			
t _S	Setup Time, Data to TCK (Note 2)	5.0		2.7	ns	4-11
t _H	Hold Time, Data to TCK (Note 2)	5.0		2.4	ns	4-11
t _S	Setup Time, H or L A _{OE} ₁ , B _{OE} ₁ to TCK (Note 1)	5.0		5.1	ns	4-11
t _H	Hold Time, H or L TCK to A _{OE} ₁ , B _{OE} ₁ (Note 1)	5.0		1.8	ns	4-11
t _S	Setup Time, H or L Internal AOE, BOE, to TCK (Note 3)	5.0		3.5	ns	4-11
t _H	Hold Time, H or L TCK to Internal AOE, BOE (Note 3)	5.0		1.8	ns	4-11
t _S	Setup Time ALE, BLE (Note 4) to TCK	5.0		5.1	ns	4-11
t _H	Hold Time TCK to ALE, BLE (Note 4)	5.0		1.8	ns	4-11
t _S	Setup Time, H or L TMS to TCK	5.0		7.9	ns	4-11
t _H	Hold Time, H or L TCK to TMS	5.0		1.8	ns	4-11
t _S	Setup Time, H or L TDI to TCK	5.0		6.0	ns	4-11
t _H	Hold Time, H or L TCK to TDI	5.0		3.0	ns	4-11
t _W	Pulse Width TCK	H L		10.3 10.3	ns	4-12
f _{max}	Maximum TCK Clock Frequency	5.0		50	MHz	
t _{PU}	Wait Time, Power Up to TCK	5.0		100	ns	
t _{DN}	Power Down Delay	0.0		100	ms	

*Voltage Range 5.0V ± 0.5V.

All Input Timing Delays involving TCK are measured from the rising edge of TCK.

Note 1: Timing pertains to BSR 38 and 41 only.**Note 2:** This delay represents the timing relationship between the data input and TCK at the associated scan cells numbered 0-8, 9-17, 18-26 and 27-35.**Note 3:** This delay represents the timing relationship between AOE/BOE and TCK for scan cells 36 and 39 only.**Note 4:** Timing pertains to BSR 37 and 40 only.

Capacitance

Symbol	Parameter	Typ	Units	Conditions, T _A = 25°C
C _{IN}	Input Capacitance	5.8	pF	V _{CC} = 0.0V
C _{OUT} (Note 1)	Output Capacitance	13.8	pF	V _{CC} = 5.0V

Note 1: C_{OUT} is measured at frequency f = 1 MHz, per MIL-STD-883B, Method 3012