

PHOTOCOUPLER  
**PS9313L, PS9313L2**

**1 Mbps, OPEN COLLECTOR OUTPUT TYPE,  
HIGH CMR, INTELLIGENT POWER MODULE DRIVE  
8 mm CREEPAGE 6-PIN SDIP PHOTOCOUPLER –NEPOC Series–**

**DESCRIPTION**

The PS9313L and PS9313L2 are optical coupled isolators containing a GaAlAs LED on the input side and a photo diode and a signal processing circuit on the output side on one chip.

The PS9313L and PS9313L2 are specified high CMR, high CTR and pulse width distortion with operating temperature. It is suitable for IPM drive.

The PS9313L is lead bending type (Gull-wing) for surface mounting.

The PS9313L2 is lead bending type for long creepage distance (Gull-wing) for surface mount.

**FEATURES**

- High common mode transient immunity ( $CM_H, CM_L = \pm 15 \text{ kV}/\mu\text{s}$  MIN.)
- Half size of 8-pin DIP
- Long creepage distance (8 mm MIN. : PS9313L2)
- High-speed response ( $t_{PHL} = 500 \text{ ns}$  MAX.,  $t_{PLH} = 750 \text{ ns}$  MAX.)
- Maximum propagation delays ( $t_{PLH} - t_{PHL} = 220 \text{ ns}$  TYP.)
- Pulse width distortion ( $|t_{PHL} - t_{PLH}| = 220 \text{ ns}$  TYP.)
- High isolation voltage ( $BV = 5\,000 \text{ Vr.m.s.}$ )
- Open collector output
- Pb-Free product
- Safety standards
  - UL approved: File No. E72422
  - CSA approved: No. CA 101391
  - DIN EN60747-5-2 (VDE0884 Part2) approved: No. 40024069 (Option)

<R>

**APPLICATIONS**

- IPM Driver
- General purpose inverter

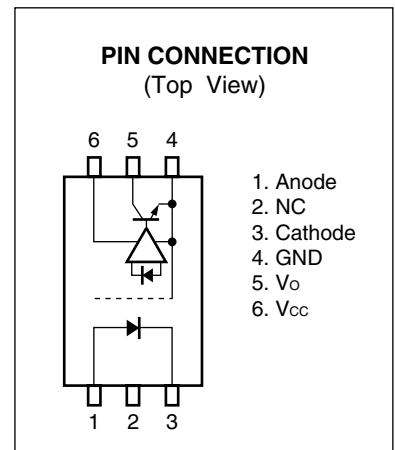

**TRUTH TABLE**

LED	Output
ON	L
OFF	H

The information in this document is subject to change without notice. Before using this document, please confirm that this is the latest version.  
Not all products and/or types are available in every country. Please check with an NEC Electronics sales representative for availability and additional information.

PACKAGE DIMENSIONS (UNIT: mm)

Lead Bending Type (Gull-wing) For Surface Mount

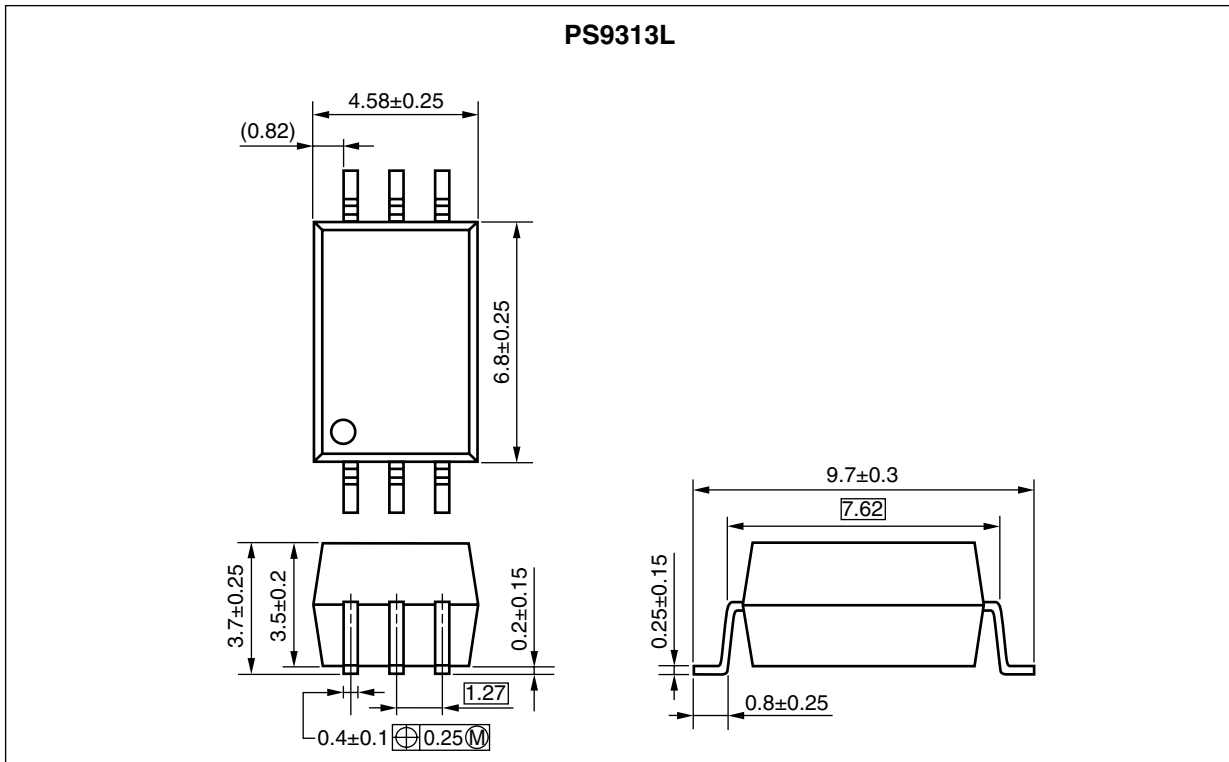

Lead Bending Type For Long Creepage Distance (Gull-wing) For Surface Mount

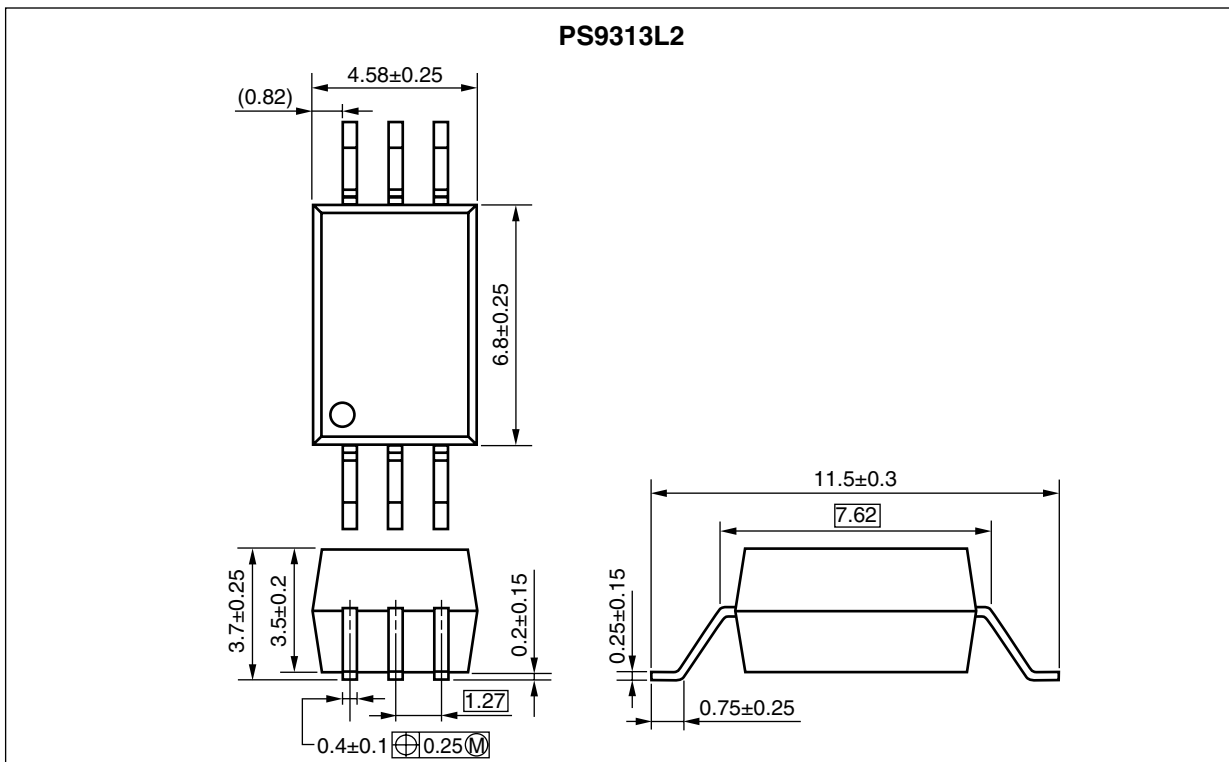

<R> MARKING EXAMPLE

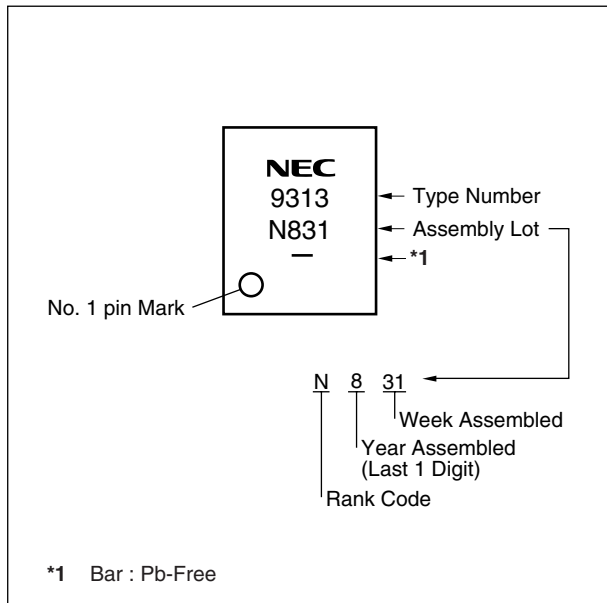

PHOTOCOUPLER CONSTRUCTION

Parameter	PS9313L	PS9313L2
Air Distance (MIN.)	7 mm	8 mm
Outer Creepage Distance (MIN.)	7 mm	8 mm
Isolation Distance (MIN.)	0.4 mm	0.4 mm

<R> ORDERING INFORMATION

Part Number	Order Number	Solder Plating Specification	Packing Style	Safety Standard Approval	Application Part Number <sup>*1</sup>
PS9313L	PS9313L-AX	Pb-Free (Ni/Pd/Au)	20 pcs (Tape 20 pcs cut)	Standard products (UL, CSA approved)	PS9313L
PS9313L-E3	PS9313L-E3-AX		Embossed Tape 2 000 pcs/reel		
PS9313L2	PS9313L2-AX		20 pcs (Tape 20 pcs cut)		PS9313L2
PS9313L2-E3	PS9313L2-E3-AX		Embossed Tape 2 000 pcs/reel		
PS9313L-V	PS9313L-V-AX		20 pcs (Tape 20 pcs cut)	DIN EN60747-5-2 (VDE0884 Part2)	PS9313L
PS9313L-E3-V	PS9313L-E3-V-AX		Embossed Tape 2 000 pcs/reel		
PS9313L2-V	PS9313L2-V-AX		20 pcs (Tape 20 pcs cut)	Approved (Option)	PS9313L2
PS9313L2-E3-V	PS9313L2-E3-V-AX		Embossed Tape 2 000 pcs/reel		

\*1 For the application of the Safety Standard, following part number should be used.

**ABSOLUTE MAXIMUM RATINGS (T<sub>A</sub> = 25°C, unless otherwise specified)**

Parameter		Symbol	Ratings	Unit
Diode	Forward Current <sup>1</sup>	I <sub>F</sub>	25	mA
	Reverse Voltage	V <sub>R</sub>	5	V
Detector	Supply Voltage	V <sub>CC</sub>	-0.5 to +35	V
	Output Voltage	V <sub>O</sub>	-0.5 to +35	V
	Output Current	I <sub>O</sub>	15	mA
	Power Dissipation <sup>2</sup>	P <sub>C</sub>	100	mW
Isolation Voltage <sup>3</sup>		BV	5 000	Vr.m.s.
Operating Ambient Temperature		T <sub>A</sub>	-40 to +110	°C
Storage Temperature		T <sub>stg</sub>	-55 to +125	°C

\*1 Reduced to 0.33 mA/°C at T<sub>A</sub> = 70°C or more.

\*2 Reduced to 2.0 mW/°C at T<sub>A</sub> = 75°C or more.

\*3 AC voltage for 1 minute at T<sub>A</sub> = 25°C, RH = 60% between input and output.  
Pins 1-3 shorted together, 4-6 shorted together.

**RECOMMENDED OPERATING CONDITIONS**

Parameter	Symbol	MIN.	TYP.	MAX.	Unit
Supply Voltage	V <sub>CC</sub>	4.5	15	30	V
Output Voltage	V <sub>O</sub>	0		30	V
Forward Current (ON)	I <sub>F (ON)</sub>	8		12	mA
Forward Voltage (OFF)	V <sub>F (OFF)</sub>	0		0.8	V

**ELECTRICAL CHARACTERISTICS (T<sub>A</sub> = -40 to +110°C, V<sub>CC</sub> = 15 V, unless otherwise specified)**

Parameter		Symbol	Conditions	MIN.	TYP.*1	MAX.	Unit
Diode	Forward Voltage	V <sub>F</sub>	I <sub>F</sub> = 10 mA, T <sub>A</sub> = 25°C	1.2	1.56	1.9	V
	Reverse Current	I <sub>R</sub>	V <sub>R</sub> = 3 V, T <sub>A</sub> = 25°C			10	μA
	Terminal Capacitance	C <sub>t</sub>	V = 0 V, f = 1 MHz		60		pF
Detector	Low Level Output Voltage	V <sub>OL</sub>	I <sub>F</sub> = 10 mA, I <sub>OL</sub> = 2.4 mA		0.13	0.6	V
	High Level Output Current	I <sub>OH</sub>	V <sub>CC</sub> = 30 V, V <sub>F</sub> = 0.8 V		1.0	50	μA
	High Level Supply Current	I <sub>COH</sub>	V <sub>CC</sub> = 30 V, V <sub>F</sub> = 0.8 V, V <sub>O</sub> = open		0.6	1.3	mA
	Low Level Supply Current	I <sub>COL</sub>	V <sub>CC</sub> = 30 V, I <sub>F</sub> = 10 mA, V <sub>O</sub> = open		0.7	1.3	mA
Coupled	Threshold Input Current (H → L)	I <sub>FHL</sub>	V <sub>O</sub> = 0.8 V, I <sub>O</sub> = 0.75 mA		0.75	5.0	mA
	Current Transfer Ratio (I <sub>O</sub> /I <sub>F</sub> )	CTR	I <sub>F</sub> = 10 mA, V <sub>O</sub> = 0.6 V	44	110		%
	Isolation Resistance	R <sub>I-O</sub>	V <sub>I-O</sub> = 1 kV <sub>DC</sub>	10 <sup>11</sup>			Ω
	Isolation Capacitance	C <sub>I-O</sub>	V = 0 V, f = 1 MHz		0.7		pF
	Propagation Delay Time (H → L)	t <sub>PHL</sub>	I <sub>F</sub> = 10 mA, R <sub>L</sub> = 20 kΩ, C <sub>L</sub> = 100 pF, V <sub>THHL</sub> = 1.5 V, V <sub>THLH</sub> = 2.0 V		240	500	ns
	Propagation Delay Time (L → H)	t <sub>PLH</sub>			460	750	
	Maximum Propagation Delays	t <sub>PLH</sub> -t <sub>PHL</sub>		-200	220	650	
	Pulse Width Distortion (PWD)	t <sub>PHL</sub> -t <sub>PLH</sub>			220	650	
	Common Mode Transient Immunity at High Level Output	CM <sub>H</sub>		T <sub>A</sub> = 25°C, I <sub>F</sub> = 0 mA, V <sub>O</sub> > 3.0 V, V <sub>CM</sub> = 1.5 kV, R <sub>L</sub> = 20 kΩ, C <sub>L</sub> = 100 pF	15		
Common Mode Transient Immunity at Low Level Output	CM <sub>L</sub>	T <sub>A</sub> = 25°C, I <sub>F</sub> = 10 mA, V <sub>O</sub> < 1.0 V, V <sub>CM</sub> = 1.5 kV, R <sub>L</sub> = 20 kΩ, C <sub>L</sub> = 100 pF	15			kV/μs	

\*1 Typical values at T<sub>A</sub> = 25°C.

**USAGE CAUTIONS**

1. This product is weak for static electricity by designed with high-speed integrated circuit so protect against static electricity when handling.
2. By-pass capacitor of 0.1  $\mu$ F is used between Vcc and GND near device. Also, ensure that the distance between the leads of the photocoupler and capacitor is no more than 10 mm.
3. Avoid storage at a high temperature and high humidity.

**NOTES ON HANDLING****Cautions regarding noise**

Be aware that when voltage is applied suddenly between the photocoupler's input and output or between collector-emitters at startup, the output transistor may enter the on state, even if the voltage is within the absolute maximum ratings.

<R> SPECIFICATION OF VDE MARKS LICENSE DOCUMENT

Parameter	Symbol	Speck	Unit
Application classification (DIN EN 60664-1 VDE0110 Part 1) for rated line voltages ≤ 300 Vr.m.s. for rated line voltages ≤ 600 Vr.m.s.		IV III	
Climatic test class (DIN EN 60664-1 VDE0110)		40/110/21	
Dielectric strength maximum operating isolation voltage Test voltage (partial discharge test, procedure a for type test and random test) $U_{pr} = 1.5 \times U_{IORM}, P_d < 5 \text{ pC}$	$U_{IORM}$ $U_{pr}$	1 130 1 695	$V_{peak}$ $V_{peak}$
Test voltage (partial discharge test, procedure b for all devices) $U_{pr} = 1.875 \times U_{IORM}, P_d < 5 \text{ pC}$	$U_{pr}$	2 119	$V_{peak}$
Highest permissible overvoltage	$U_{TR}$	8 000	$V_{peak}$
Degree of pollution (DIN EN 60664-1 VDE0110 Part 1)		2	
Clearance distance	PS9313L	>7.0	mm
	PS9313L2	>8.0	
Creepage distance	PS9313L	>7.0	mm
	PS9313L2	>8.0	
Comparative tracking index (DIN IEC 112/VDE 0303 Part 1)	CTI	175	
Material group (DIN EN 60664-1 VDE0110 Part 1)		III a	
Storage temperature range	$T_{stg}$	-55 to +125	°C
Operating temperature range	$T_A$	-40 to +110	°C
Isolation resistance, minimum value $V_{IO} = 500 \text{ V dc at } T_A = 25^\circ\text{C}$ $V_{IO} = 500 \text{ V dc at } T_A \text{ MAX. at least } 100^\circ\text{C}$	$R_{is \text{ MIN.}}$ $R_{is \text{ MIN.}}$	$10^{12}$ $10^{11}$	$\Omega$ $\Omega$
Safety maximum ratings (maximum permissible in case of fault, see thermal derating curve) Package temperature Current (input current $I_F$ , $P_{si} = 0$ ) Power (output or total power dissipation) Isolation resistance $V_{IO} = 500 \text{ V dc at } T_A = T_{si}$	$T_{si}$ $I_{si}$ $P_{si}$ $R_{is \text{ MIN.}}$	175 400 700 $10^9$	°C mA mW $\Omega$

- **The information in this document is current as of August, 2008. The information is subject to change without notice. For actual design-in, refer to the latest publications of NEC Electronics data sheets or data books, etc., for the most up-to-date specifications of NEC Electronics products. Not all products and/or types are available in every country. Please check with an NEC Electronics sales representative for availability and additional information.**

- No part of this document may be copied or reproduced in any form or by any means without the prior written consent of NEC Electronics. NEC Electronics assumes no responsibility for any errors that may appear in this document.
- NEC Electronics does not assume any liability for infringement of patents, copyrights or other intellectual property rights of third parties by or arising from the use of NEC Electronics products listed in this document or any other liability arising from the use of such products. No license, express, implied or otherwise, is granted under any patents, copyrights or other intellectual property rights of NEC Electronics or others.
- Descriptions of circuits, software and other related information in this document are provided for illustrative purposes in semiconductor product operation and application examples. The incorporation of these circuits, software and information in the design of a customer's equipment shall be done under the full responsibility of the customer. NEC Electronics assumes no responsibility for any losses incurred by customers or third parties arising from the use of these circuits, software and information.
- While NEC Electronics endeavors to enhance the quality, reliability and safety of NEC Electronics products, customers agree and acknowledge that the possibility of defects thereof cannot be eliminated entirely. To minimize risks of damage to property or injury (including death) to persons arising from defects in NEC Electronics products, customers must incorporate sufficient safety measures in their design, such as redundancy, fire-containment and anti-failure features.
- NEC Electronics products are classified into the following three quality grades: "Standard", "Special" and "Specific".

The "Specific" quality grade applies only to NEC Electronics products developed based on a customer-designated "quality assurance program" for a specific application. The recommended applications of an NEC Electronics product depend on its quality grade, as indicated below. Customers must check the quality grade of each NEC Electronics product before using it in a particular application.

"Standard": Computers, office equipment, communications equipment, test and measurement equipment, audio and visual equipment, home electronic appliances, machine tools, personal electronic equipment and industrial robots.

"Special": Transportation equipment (automobiles, trains, ships, etc.), traffic control systems, anti-disaster systems, anti-crime systems, safety equipment and medical equipment (not specifically designed for life support).

"Specific": Aircraft, aerospace equipment, submersible repeaters, nuclear reactor control systems, life support systems and medical equipment for life support, etc.

The quality grade of NEC Electronics products is "Standard" unless otherwise expressly specified in NEC Electronics data sheets or data books, etc. If customers wish to use NEC Electronics products in applications not intended by NEC Electronics, they must contact an NEC Electronics sales representative in advance to determine NEC Electronics' willingness to support a given application.

(Note)

- (1) "NEC Electronics" as used in this statement means NEC Electronics Corporation and also includes its majority-owned subsidiaries.
- (2) "NEC Electronics products" means any product developed or manufactured by or for NEC Electronics (as defined above).

<p><b>Caution</b> GaAs Products</p>	<p>This product uses gallium arsenide (GaAs). GaAs vapor and powder are hazardous to human health if inhaled or ingested, so please observe the following points.</p> <ul style="list-style-type: none"> <li>• Follow related laws and ordinances when disposing of the product. If there are no applicable laws and/or ordinances, dispose of the product as recommended below.               <ol style="list-style-type: none"> <li>1. Commission a disposal company able to (with a license to) collect, transport and dispose of materials that contain arsenic and other such industrial waste materials.</li> <li>2. Exclude the product from general industrial waste and household garbage, and ensure that the product is controlled (as industrial waste subject to special control) up until final disposal.</li> </ol> </li> <li>• Do not burn, destroy, cut, crush, or chemically dissolve the product.</li> <li>• Do not lick the product or in any way allow it to enter the mouth.</li> </ul>
-------------------------------------	---------------------------------------------------------------------------------------------------------------------------------------------------------------------------------------------------------------------------------------------------------------------------------------------------------------------------------------------------------------------------------------------------------------------------------------------------------------------------------------------------------------------------------------------------------------------------------------------------------------------------------------------------------------------------------------------------------------------------------------------------------------------------------------------------------------------------------------------------------------------------------------------------------------------------------------------------------------------------------------------------------------