

### FEATURES

- **Fast acquisition time:**
  - 10ns to  $\pm 0.1\%$
  - 15ns to  $\pm 0.024\%$
  - 20ns to  $\pm 0.012\%$
- $\pm 0.006\%$  Nonlinearity
- 65 $\mu$ Vrms output noise
- 120MHz small signal bandwidth
- 55MHz full power bandwidth
- -80dB feedthrough
- 1ps Aperture jitter
- 250mW power dissipation
- Low cost

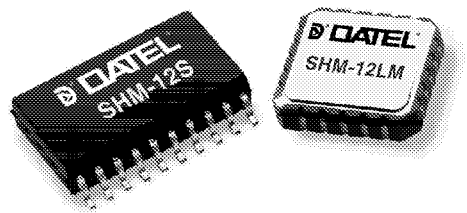

### INPUT/OUTPUT CONNECTIONS (CLCC and SOIC-20 Packages)

PIN	FUNCTION	PIN	FUNCTION
1	-5V SUPPLY	20	+5V SUPPLY
2	-5V SUPPLY	19	SAMPLE/HOLD
3	NOT CONNECTED	18	SAMPLE/HOLD
4	ANALOG INPUT	17	+5V SUPPLY
5	-5V SUPPLY	16	GROUND
6	DO NOT CONNECT	15	EXT. CAPACITOR
7	-5V SUPPLY	14	GROUND
8	DO NOT CONNECT	13	+5V SUPPLY
9	-5V SUPPLY	12	+5V SUPPLY
10	-5V SUPPLY	11	ANALOG OUTPUT

### GENERAL DESCRIPTION

The SHM-12 is an extremely high-speed and accurate monolithic sample-and-hold amplifier designed for fast data acquisition applications. The SHM-12 is accurate ( $\pm 1$ LSB at 12 bits over the full military temperature range) and is very fast (10ns and 15ns acquisition times to accuracies of 10 and 12-bits, respectively). With this high performance and a full power bandwidth of 55MHz, the SHM-12 is an ideal device for driving flash and high-resolution subranging A/D converters.

A careful design optimizes the device for accuracy and speed over the full military temperature range. The droop rate is a low  $\pm 0.5$ mV/ $\mu$ s. The 30mA output current and guaranteed specifications for a 100 $\Omega$  load provide high drive capability. Operating from  $\pm 5$ V supplies, the SHM-12 consumes only 250mW of power.

The SHM-12 is built using a fast complementary bipolar process. The device is available in both military and industrial temperature ranges. The SHM-12 is packaged in a 20-pin plastic SOIC or ceramic LCC.

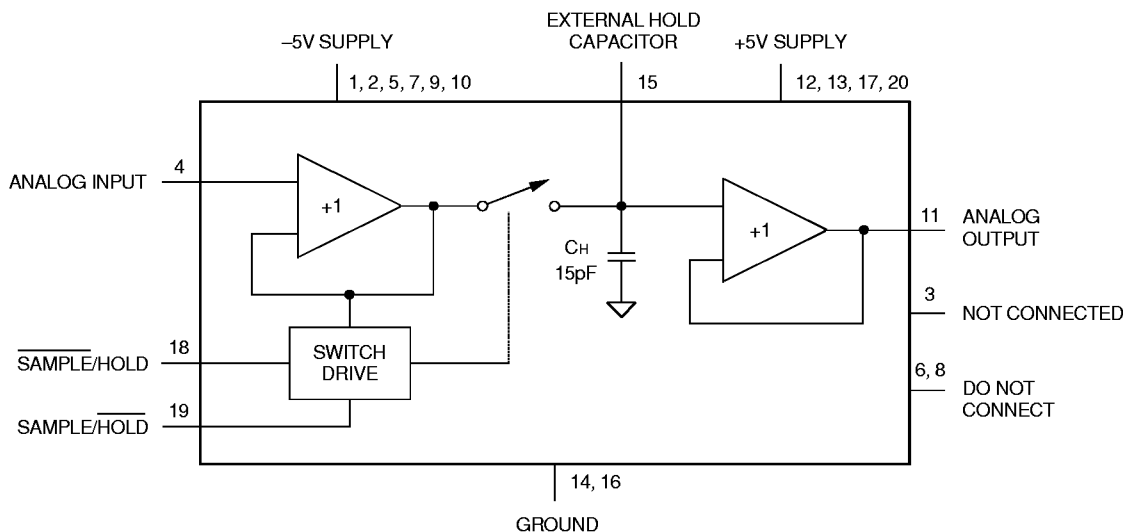

**Figure 1. SHM-12 Functional Block Diagram**

## ABSOLUTE MAXIMUM RATINGS

PARAMETERS	LIMITS	UNITS
+5V Supply	0 to +6	Volts
-5V Supply	0 to -6	Volts
Analog Input	+5V Supply -1 -5V Supply +1	Volts
Continuous Output Current	±50	mA
Digital Inputs	<Supply Voltages	Volts
Junction Temperature	+175	°C
Lead Temperature (10 seconds)	+300	°C

Output shorted to any supply will cause permanent damage.

## FUNCTIONAL SPECIFICATIONS

(Apply over the operating temperature range using a 100Ω resistive load, 10pF capacitive load, ECL digital input levels, a 47pF external hold capacitor, and ±5V nominal supplies, unless otherwise specified.)

INPUTS	MIN.	TYP.	MAX.	UNITS
Input Voltage Range	-1.5	—	+1.5	Volts
Input Impedance	0.3	1	—	MΩ
Digital Inputs (Balanced ECL)				
Logic Levels				
Logic 1	-1.5	—	+1.8	Volts
Logic 0	-2.5	—	+0.8	Volts
Logic Loading				
Logic 1	—	+10	+50	μA
Logic 0	—	-30	-150	μA
<b>OUTPUTS</b>				
Output Voltage Range	-1.5	—	+1.5	Volts
Output Current $\ominus$	±30	—	—	mA
Output Impedance (dc)	—	0.3	1	Ω
Stable Capacitive Load	—	—	50	pF
<b>PERFORMANCE</b>				
Nonlinearity (±1V)				
+25°C	—	±0.006	—	%
-40 to +85°C	—	—	±0.024	%
-55 to +125°C	—	—	±0.024	%
Sample Mode Offset				
+25°C	—	±12	—	mV
-40 to +85°C	—	—	±20	mV
-55 to +125°C	—	—	±30	mV
Pedestal				
+25°C	—	±3	—	mV
-40 to +85°C	—	—	±20	mV
-55 to +125°C	—	—	±20	mV
Gain, +25°C	+0.98	+0.995	—	V/V
Gain Drift (±1V)				
-40 to +85°C	—	—	±20	ppm/°C
-55 to +125°C	—	—	±30	ppm/°C
Aperture Delay				
-40 to +85°C	—	2	—	ns
-55 to +125°C	—	2	—	ns
Aperture Jitter				
-40 to +85°C	—	1	—	ps rms
-55 to +125°C	—	1	—	ps rms
Harmonic Distortion (±1V)				
dc to 1MHz	—	-75	—	dB
dc to 10MHz				
+25°C	—	-62	—	dB
-40 to +85°C	—	—	-56	dB
-55 to +125°C	—	—	-54	dB
Acquisition Time (±0.012%, ±1V)				
-40 to +85°C	—	20	—	ns
-55 to +125°C	—	30	—	ns
Acquisition Time (±0.024%, ±1V)				
-40 to +85°C	—	15	30	ns
-55 to +125°C	—	25	40	ns
Acquisition Time (±0.05%, ±1V)				
-40 to +85°C	—	12	25	ns
-55 to +125°C	—	15	30	ns

PERFORMANCE (Cont.)	MIN.	TYP.	MAX.	UNITS
Acquisition Time (±0.1%, ±1V)				
-40 to +85°C	—	10	20	ns
-55 to +125°C	—	10	20	ns
Hold Mode Settling (±0.012%)				
-40 to +85°C	—	10	—	ns
-55 to +125°C	—	10	—	ns
Hold Mode Settling (±0.024%)				
-40 to +85°C	—	7	18	ns
-55 to +125°C	—	7	18	ns
Hold Mode Settling (±0.05%)				
-40 to +85°C	—	6	15	ns
-55 to +125°C	—	6	15	ns
Hold Mode Settling (±0.1%)				
-40 to +85°C	—	5	12	ns
-55 to +125°C	—	5	12	ns
Slew Rate	±220	±350	—	V/μs
Full Power Bandwidth (±1V)	35	55	—	MHz
Small Signal Bandwidth	50	120	—	MHz
Output Noise, Hold Mode	—	65	—	μVrms
Feedthrough (2V Step)	—	-80	—	dB
Droop Rate				
+25°C	—	±0.5	±1.5	mV/μs
-40 to +85°C	—	±2	±5	mV/μs
-55 to +125°C	—	±2.5	±10	mV/μs
<b>POWER SUPPLY REQUIREMENTS</b>				
Power Supply Range				
+5V Supply	+4.5	+5	+5.5	Volts
-5V Supply	-5.5	-5	-4.5	Volts
Power Supply Current				
+5V Supply	+17	+25	+30	mA
-5V Supply	-17	-25	-30	mA
Power Dissipation	170	250	300	mW
Power Supply Rejection Ratio	40	60	—	dB
<b>ENVIRONMENTAL</b>				
Operating Temp. Range, Case				
SHM-12S, SHM-12L	-40	—	+85	°C
SHM-12LM	-55	—	+125	°C
Storage Temperature Range	-65	—	+150	°C
Package Type				
SHM-12S	20-Pin plastic SOIC			
SHM-12L, SHM-12LM	20-Pin ceramic LCC			

## Footnotes:

⊖ Short circuit protection at ±50mA.

## TECHNICAL NOTES

The SHM-12 employs an open loop architecture to achieve its superior high-speed characteristics. The first stage buffer amplifier incorporates the sample-and-hold switch. This allows for a fast acquisition time which is not limited by slew current like the traditional Schottky diode bridge switch. The output amplifier uses a closed loop voltage feedback design which provides a low (0.3Ω, typical) output impedance. Gain and linearity are not affected by heavy loads.

The design has been optimized to achieve the high accuracy associated with fast transient responses over the military temperature range. During the track-to-hold transient, the integral nonlinearity is not affected and the pedestal remains constant over the full ±1.5V input range.

An innovative circuit design ensures an extremely low droop rate. An external hold capacitor can be added to the 15pF internal hold capacitor to obtain a lower droop rate (the droop rate is proportional to the inverse of the total hold capacitor value) without increasing transient response times by more than a few ns. The external hold capacitor should not exceed 100pF.

**GROUNDING AND LAYOUT**

Obtaining fully specified performance from the SHM-12 requires careful attention to pc-board layout and power supply decoupling.

For optimal performance, tie all grounds directly to a large analog ground plane beneath and around the package. Bypass all power supplies to ground with 10µF tantalum capacitors in parallel with 0.1µF ceramic capacitors.

Locate the bypass capacitors as close to the unit as possible.

For best performance, controlled impedance transmission line techniques, such as microstrip, should be used. Mount all components as close to the required pins as possible. It is strongly recommended that the SHM-12 not be socket-mounted.

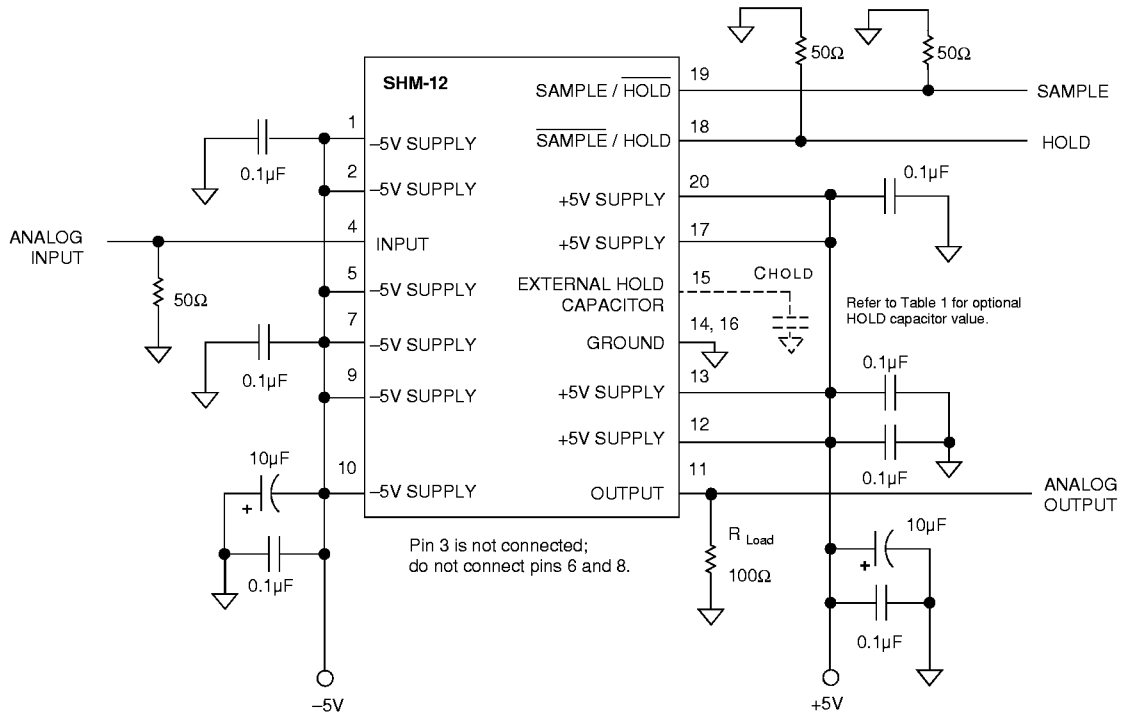

**Figure 2. SHM-12 Simplified Connection Diagram**

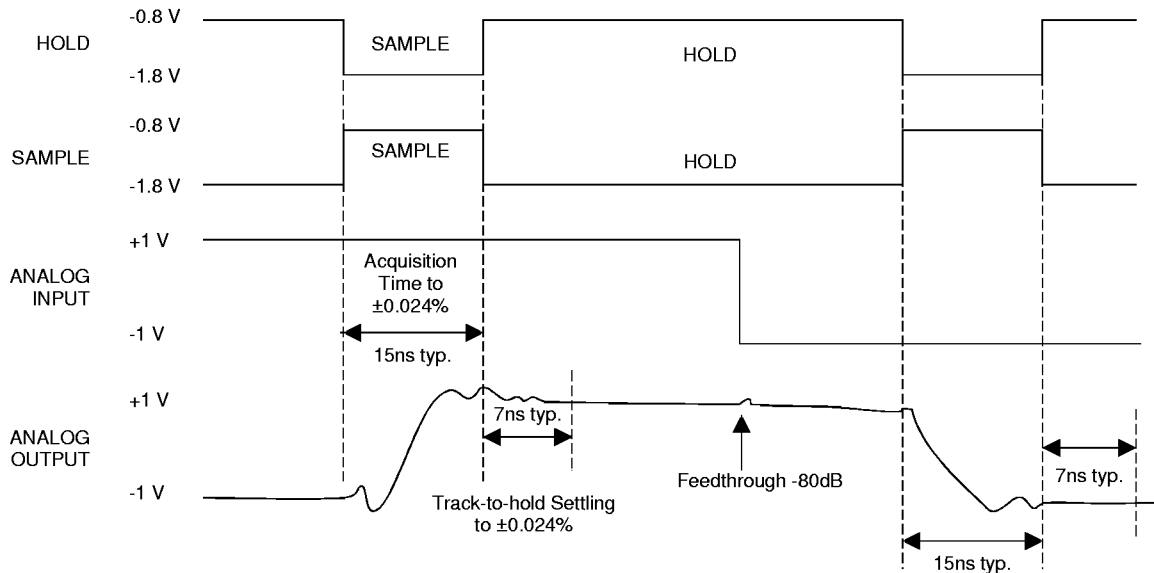

**Figure 3. SHM-12 Control and Timing**

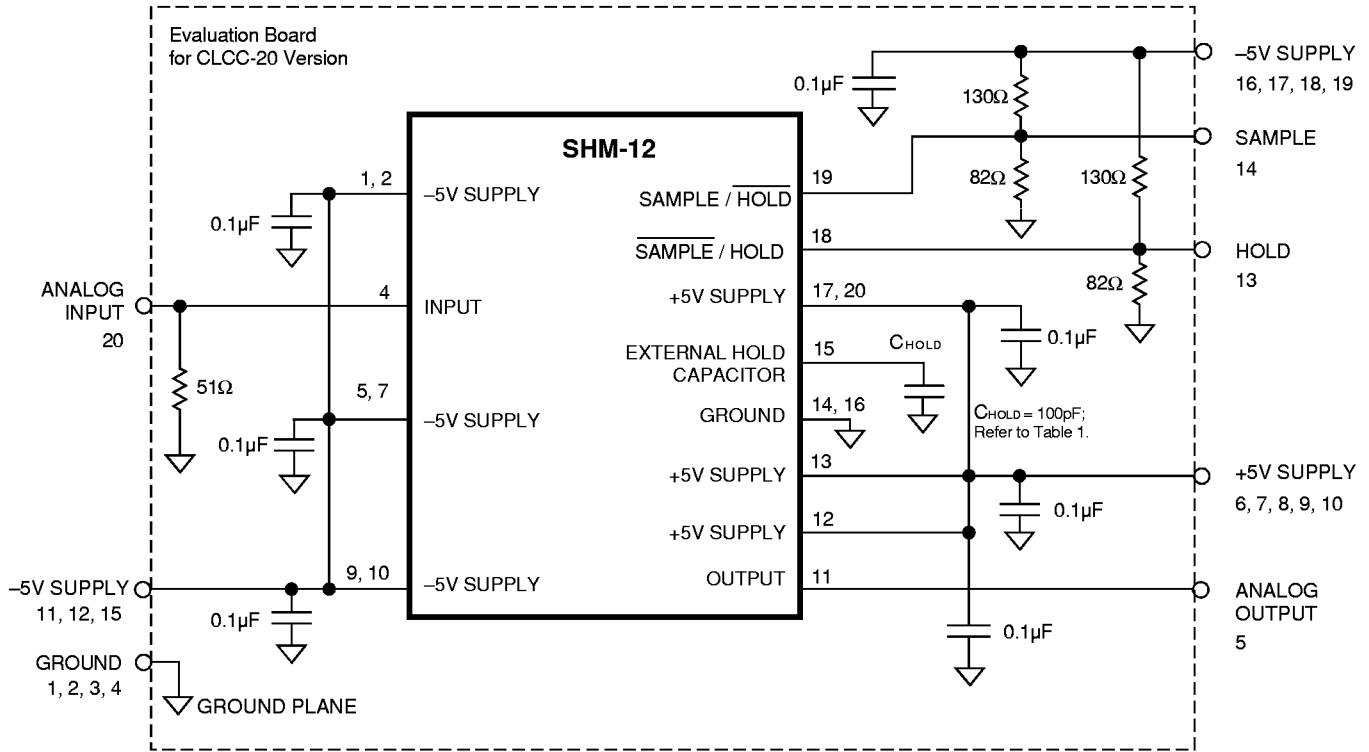

Figure 4. SHM-12 Evaluation Board Schematic

Table 1. Optional External HOLD Capacitor

Model	Operating Temperature Range	Type of HOLD Capacitor (Ceramic, ≤100pF, ±10%)
SHM-12L, -12S SHM-12LM	-40 to +85°C -55 to +125°C	Type I or II, NPO or X7R Type I or NPO

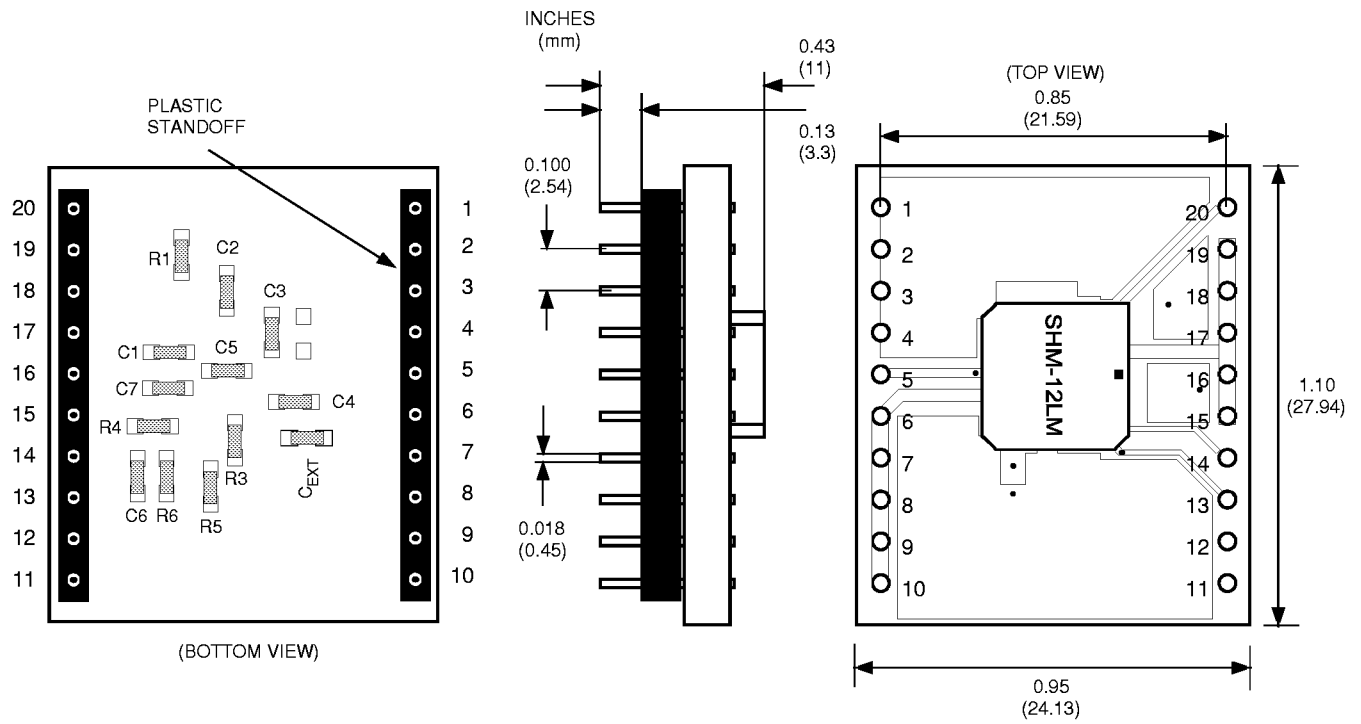

Figure 5. SHM-12 Evaluation Board Dimensions

**SHM-12 Evaluation Board Connections**

PIN	FUNCTION
1	GROUND
2	GROUND
3	GROUND
4	GROUND
5	ANALOG OUTPUT
6	+5V SUPPLY
7	+5V SUPPLY
8	+5V SUPPLY
9	+5V SUPPLY
10	+5V SUPPLY
11	-5V SUPPLY
12	-5V SUPPLY
13	HOLD
14	SAMPLE
15	-5V SUPPLY
16	-5V SUPPLY
17	-5V SUPPLY
18	-5V SUPPLY
19	-5V SUPPLY
20	ANALOG INPUT

**MECHANICAL DIMENSIONS**

**SOIC-20 Package**

SYMBOL	INCHES		MILLIMETERS	
	MIN.	MAX.	MIN.	MAX.
A	0.500	0.510	12.70	12.95
B	0.400	0.410	10.16	10.41
C	0.292	0.299	7.40	7.60
D	0.014	0.019	0.35	0.48
E	0.0500 BSC		1.27 BSC	
F	0.0039	0.0112	0.10	0.30
G	0°	8°	0°	8°
H	0.020	0.040	0.51	1.02
J	0.097	0.104	2.46	2.64
K	0.010	0.020	0.25	0.51
L	0.0091	0.0125	0.23	0.32

**CLCC-20 Package**

SYMBOL	INCHES		MILLIMETERS	
	MIN.	MAX.	MIN.	MAX.
A	0.064	0.100	1.63	2.54
B	0.045	0.055	1.14	1.40
C	0.075 REF		1.91 REF	
D	0.342	0.358	8.69	9.09
E	0.022	0.028	0.56	0.71
F	0.020 REF		0.51	
G	0.050 BSC		1.27 BSC	
H	0.040 REF		1.02	

**ORDERING INFORMATION**

MODEL NUMBER	PACKAGE	TEMPERATURE RANGE
<b>SHM-12S</b>	SOIC-20	-40 to +85°C
<b>SHM-12L</b>	CLCC-20	-40 to +85°C
<b>SHM-12LM</b>	CLCC-20	-55 to +125°C
<b>EVB-SHM12</b>	Evaluation Board (with SHM-12LM)	

Contact DATEL for availability of high-reliability models.