

OKI Semiconductor

MK32VT1632-10YC

16,777,216 Word x 32 Bit SYNCHRONOUS DYNAMIC RAM MODULE (2BANK):

DESCRIPTION

The Oki MK32VT1632-10YC is a fully decoded, 16,777,216 x 32bit synchronous dynamic random access memory composed of eight 64Mb DRAMs (8Mx8) in TSOP packages mounted with decoupling capacitors on a 168-pin glass epoxy Dual-in-Line Package supports any application where high density and large capacity of storage memory are required, like for example PCs or servers.

FEATURES

- 16-Meg Word x 32-bit (2Bank 4Byte) organization
- 100-pin Dual Inline Memory Module
- All DQ Pins have 10 Ω Damping Resister
- Single 3.3V power supply, \pm 0.3V tolerance
- Input :LVTTL compatible
- Output :LVTTL compatible
- Refresh : 4,096 cycles/64 ms
- Programmable data transfer mode
 - /CAS latency (2, 3)
 - Burst length (2, 4, 8)
 - Data scramble (sequential, interleave)
- /CAS before /RAS auto-refresh, Self-refresh capability
- Serial Presence Detect (SPD) With EEPROM

PRODUCT ORGANIZATION

| Product Name | Operation Frequency (Max.) | Access Time (Max.) | |
|-----------------|-------------------------------|--------------------|------------------|
| | | t _{AC2} | t _{AC3} |
| MK32VT1632-10YC | 100 MHz | 9.0ns | 9.0ns |

Note. Specification are subject to change without notice.

BLOCK DIAGRAM

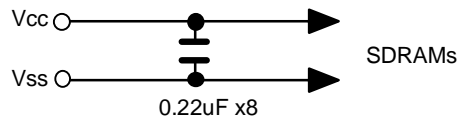
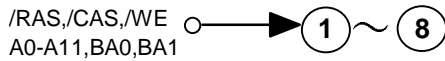
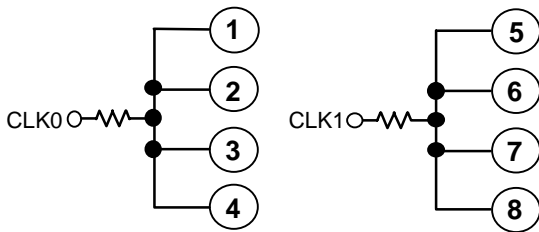
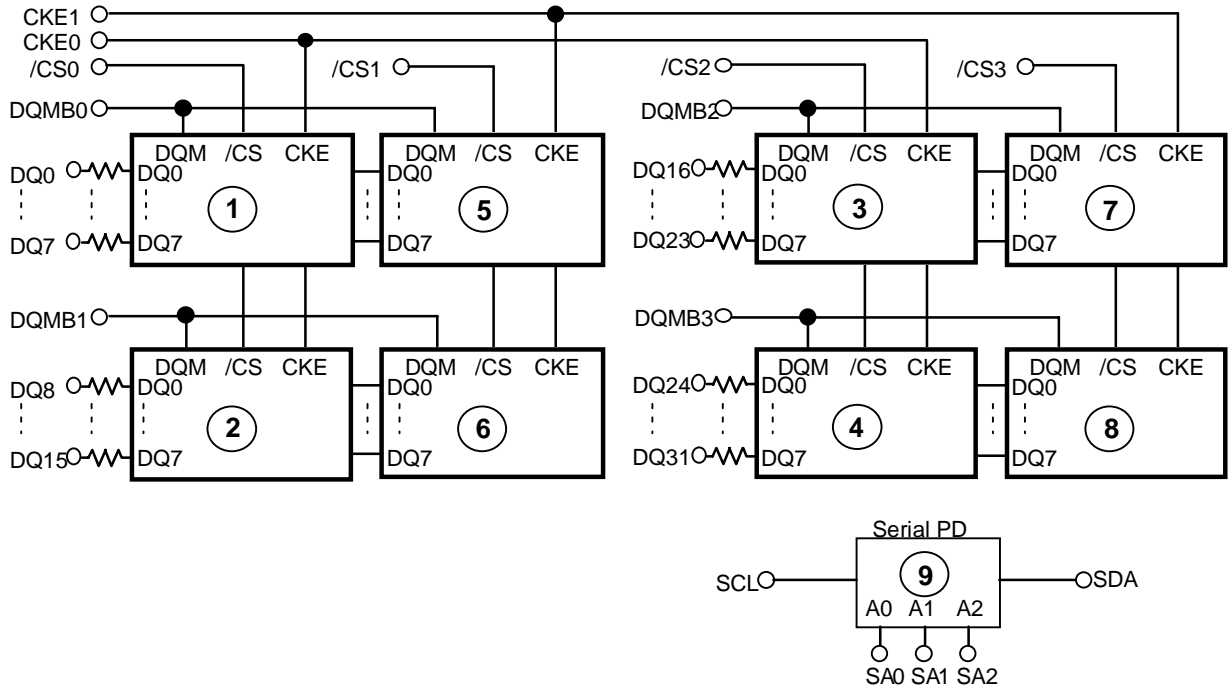

Note. The Value of all resistors is 10Ω.

MODULE OUTLINE

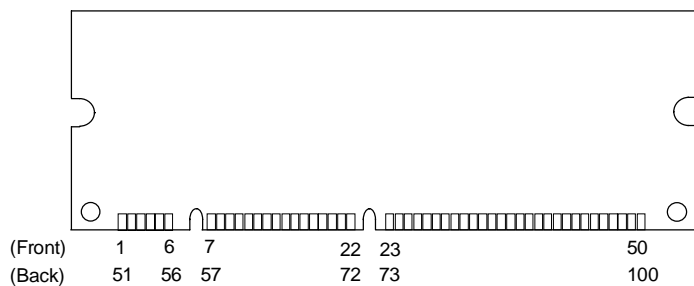

PIN CONFIGURATION

| Front side | | Back side | |
|------------|----------|-----------|----------|
| Pin No. | Pin name | Pin No. | Pin name |
| 1 | VSS | 51 | VSS |
| 2 | DQ0 | 52 | DQ8 |
| 3 | DQ1 | 53 | DQ9 |
| 4 | DQ2 | 54 | DQ10 |
| 5 | DQ3 | 55 | DQ11 |
| 6 | VCC | 56 | VCC |
| 7 | DQ4 | 57 | DQ12 |
| 8 | DQ5 | 58 | DQ13 |
| 9 | DQ6 | 59 | DQ14 |
| 10 | DQ7 | 60 | DQ15 |
| 11 | DQMB0 | 61 | DQMB1 |
| 12 | VSS | 62 | VSS |
| 13 | A0 | 63 | A1 |
| 14 | A2 | 64 | A3 |
| 15 | A4 | 65 | A5 |
| 16 | A6 | 66 | A7 |
| 17 | A8 | 67 | A9 |
| 18 | A10 | 68 | BA0 |
| 19 | BA1 | 69 | A11 |
| 20 | NC | 70 | NC |
| 21 | VCC | 71 | VCC |
| 22 | NC | 72 | /RAS |
| 23 | NC | 73 | /CAS |
| 24 | NC | 74 | NC |
| 25 | CLK0 | 75 | CLK1 |

| Front side | | Back side | |
|------------|----------|-----------|----------|
| Pin No. | Pin name | Pin No. | Pin name |
| 26 | VSS | 76 | VSS |
| 27 | CKE0 | 77 | NC |
| 28 | /WE | 78 | NC |
| 29 | /CS0 | 79 | /CS1 |
| 30 | /CS2 | 80 | /CS3 |
| 31 | VCC | 81 | VCC |
| 32 | NC | 82 | NC |
| 33 | NC | 83 | NC |
| 34 | NC | 84 | NC |
| 35 | NC | 85 | NC |
| 36 | VSS | 86 | VSS |
| 37 | DQMB2 | 87 | DQMB3 |
| 38 | DQ16 | 88 | DQ24 |
| 39 | DQ17 | 89 | DQ25 |
| 40 | DQ18 | 90 | DQ26 |
| 41 | DQ19 | 91 | DQ27 |
| 42 | VCC | 92 | VCC |
| 43 | DQ20 | 93 | DQ28 |
| 44 | DQ21 | 94 | DQ29 |
| 45 | DQ22 | 95 | DQ30 |
| 46 | DQ23 | 96 | DQ31 |
| 47 | VSS | 97 | VSS |
| 48 | SDA | 98 | SA0 |
| 49 | SCL | 99 | SA1 |
| 50 | VCC | 100 | SA2 |

| Pin Name | Function | Pin Name | Function |
|----------|-----------------------|----------|---------------------------------|
| Vcc | Power Supply (3.3V) | /WE | Write Enable |
| Vss | Ground (0V) | DQMB# | Data Input / Output Mask |
| CLK# | System Clock | DQ# | Data Input / Output |
| /CS# | Chip Select | SDA | Data I/O for SPD |
| CKE# | Clock Enable | SCL | CLK input for SPD |
| A0-A11 | Address | SA# | Socket Position Address for SPD |
| BA0, BA1 | Bank Select Address | N.C | No Connection |
| /RAS | Row Address Strobe | | |
| /CAS | Column Address Strobe | | |

SERIAL PRESENCE DETECT

| Byte No. | SPD Hex Value | Remark | Notes |
|----------|---|---|-----------------------------|
| 0 | 80 | Defines the number of bytes written into SPD memory | 128 byte |
| 1 | 08 | Total number of bytes of SPD memory | 256 byte |
| 2 | 04 | Fundamental memory type | SDRAM |
| 3 | 0C | Number of rows | 12 rows |
| 4 | 09 | Number of columns | 9 columns |
| 5 | 02 | Number of module banks | 2 bank |
| 6 | 20 | Data width of this assembly | 32 bits |
| 7 | 00 | ... Data width continuation | 0 |
| 8 | 01 | Voltage interface level | LVTTL |
| 9 | A0 | Cycle time (CL=3) | CL=3 t _{CC3} =10ns |
| 10 | 90 | Access time from CLK (CL=3) | CL=3 t _{AC3} =9ns |
| 11 | 00 | DIMM configuration type | None Parity |
| 12 | 80 | Refresh rate / type | Normal / Self |
| 13 | 08 | Primary SDRAM width | x8 |
| 14 | 00 | Error checking SDRAM width | |
| 15 | 01 | Minimum CLK delay | t _{CCD} : 1 CLK |
| 16 | 0E | Burst lengths supported | 2, 4, 8 |
| 17 | 04 | Number of banks on each SDRAM | 4 banks |
| 18 | 06 | /CAS latency | 2, 3 |
| 19 | 01 | /CS latency | 0 |
| 20 | 01 | /WE latency | 0 |
| 21 | 00 | SDRAM module attributes | |
| 22 | 06 | SDRAM device attributes : General | |
| 23 | F0 | Cycle time (CL=2) | CL=2 t _{CC2} =15ns |
| 24 | 90 | Access time from CLK (CL=2) | CL=2 t _{AC2} =9ns |
| 25 | 00 | Cycle time (CL=1) | Not support |
| 26 | 00 | Access time from CLK (CL=1) | Not support |
| 27 | 1E | Minimum ROW pulse width | t _{RP} =30ns |
| 28 | 14 | /RAS to /RAS bank delay | t _{RRD} =20ns |
| 29 | 1E | /RAS to /CAS delay | t _{RCD} =30ns |
| 30 | 3C | Minimum /RAS precharge time | t _{RAS} =60ns |
| 31 | 08 | Density of each bank on module | 32MB |
| 32 | 30 | Command and address signal input setup time | 3ns |
| 33 | 10 | Command and address signal input hold time | 1ns |
| 34 | 30 | Data signal input setup time | 3ns |
| 35 | 10 | Data signal input hold time | 1ns |
| 36-61 | 00-00 | | R.F.U |
| 62 | 02 | SPD data revision code | 0.2 |
| 63 | 33 | Checksum for byte 0-62 | |
| 64-71 | 41, 45, 20, 20, 20, 20, 20, 20 | Manufacturer's JEDEC ID code | |
| 72 | 01 / 06 | Manufacturing location | |
| 73-90 | 4D,4B,33,32,56,54,31,36,33,32,2D,31,30,59,43,20,20,20 | Manufacturer's part number | MK32VT1632-10YC |
| 91, 92 | 20, 20 | Revision code | |
| 93-125 | 00-00 | R.F.U | |
| 126 | 66 | Intel specification frequency | 66MHz |
| 127 | 06 | Intel specification /CAS latency | CL=2, 3 |
| 128-255 | FF-FF | Unused storage locations | |

ELECTRICAL CHARACTERISTICS

Absolute Maximum Ratings

| Rating | Symbol | Value | Unit |
|--|------------------------------------|------------------------------|------|
| Voltage on any pin relative to V _{SS} | V _{IN} , V _{OUT} | -0.5 to V _{CC} +0.5 | V |
| V _{CC} supply voltage | V _{CC} , V _{CCQ} | -0.5 to 4.6 | V |
| Storage temperature | T _{stg} | - 55 to 125 | °C |
| Power dissipation | P _D * | 8 | W |
| Short circuit current | I _{OS} | 50 | mA |
| Operating temperature | T _{opr} | 0 to 70 | °C |

*: T_a=25°C

Recommended Operating Conditions

(Voltages referenced to V_{SS} = 0V)

| Parameter | Symbol | Min. | Typ. | Max. | Unit |
|----------------------|------------------------------------|------|------|----------------------|------|
| Power supply voltage | V _{CC} , V _{CCQ} | 3.0 | 3.3 | 3.6 | V |
| Input high voltage | V _{IH} | 2.0 | - | V _{CC} +0.3 | V |
| Input low voltage | V _{IL} | -0.3 | - | 0.8 | V |

Capacitance

(V_{CC} = 3.3V ± 0.3V, T_a = 25°C f = 1MHz)

| Parameter | Symbol | Max. | Unit |
|---|------------------|------|------|
| Input capacitance (A0-A11, BA0, BA1, /RAS, /CAS, /WE) | C _{IN1} | 40 | pF |
| Input capacitance (/CS0, /CS1, /CS2, /CS3) | C _{IN2} | 20 | pF |
| Input capacitance (DQMB0-DQMB3) | C _{IN3} | 10 | pF |
| Input capacitance (CKE0, CKE1) | C _{IN4} | 20 | pF |
| I/O capacitance (DQ0-DQ31) | C _{I/O} | 14 | pF |
| Input capacitance (CLK0, CLK1) | C _{CLK} | 50 | pF |

DC CHARACTERISTICS

(V_{CC} = 3.3V ± 0.3V, T_a = 0 to 70°C)

| Parameter | Symbol | Condition | | Module Spec. | | Unit | Note |
|---|-------------------|--|--|--------------|------|------|------|
| | | CKE | Others | Min. | Max. | | |
| Output High Voltage | V _{OH} | - | I _{OH} = -2.0mA | 2.4 | - | V | |
| Output Low Voltage | V _{OL} | - | I _{OL} = 2.0mA | - | 0.4 | V | |
| Input Leakage Current | I _{LI} | - | - | -80 | 80 | uA | |
| Output Leakage Current | I _{LO} | - | - | -20 | 20 | uA | |
| Average Power Supply Current (Operating) | I _{CC1} | CKE ≥ V _{IH} | t _{CC} =min. t _{RC} =min. No Burst | - | 620 | mA | 1, 2 |
| Power Supply Current (Stand by) | I _{CC2} | CKE ≥ V _{IH} | t _{CC} =min. | - | 320 | mA | 3 |
| Average Power Supply Current (Clock Suspension) | I _{CC3S} | CKE ≤ V _{IL} | t _{CC} =min. | - | 220 | mA | 2 |
| Average Power Supply Current (Active Stand by) | I _{CC3} | CKE ≥ V _{IH} , /CS ≥ V _{IH} | t _{CC} =min. | - | 480 | mA | 3 |
| Power Supply Current (Burst) | I _{CC4} | CKE ≥ V _{IH} | t _{CC} =min. | - | 780 | mA | 1, 2 |
| Power Supply Current (Auto-Refresh) | I _{CC5} | CKE ≥ V _{IH} | t _{CC} =min. t _{RC} =min. | - | 900 | mA | 2 |
| Average Power Supply Current (Self-Refresh) | I _{CC6} | CKE ≤ 0.2V | t _{CC} =min. | - | 16 | mA | |
| Average Power Supply Current (Power down) | I _{CC7} | CKE ≤ V _{IL} | t _{CC} =min. | - | 16 | mA | |

- Notes: 1. Measured with the output open.
 2. Address and data can be changed once or not be changed during one cycle.
 3. Address and data can be changed once or not be changed during two cycle.

MODE SET ADDRESS KEYS

| /CAS Latency | | | | Burst Type | | Burst Length | | | | |
|--------------|----|----|----------|------------|------------|--------------|----|----|----------|----------|
| A6 | A5 | A4 | CL | A3 | BT | A2 | A1 | A0 | BT=0 | BT=1 |
| 0 | 0 | 0 | Reserved | 0 | Sequential | 0 | 0 | 0 | Reserved | Reserved |
| 0 | 0 | 1 | Reserved | 1 | Interleave | 0 | 0 | 1 | 2 | 2 |
| 0 | 1 | 0 | 2 | | | 0 | 1 | 0 | 4 | 4 |
| 0 | 1 | 1 | 3 | | | 0 | 1 | 1 | 8 | 8 |
| 1 | 0 | 0 | Reserved | | | 1 | 0 | 0 | Reserved | Reserved |
| 1 | 0 | 1 | Reserved | | | 1 | 0 | 1 | Reserved | Reserved |
| 1 | 1 | 0 | Reserved | | | 1 | 1 | 0 | Reserved | Reserved |
| 1 | 1 | 1 | Reserved | | | 1 | 1 | 1 | Reserved | Reserved |

Note: A7, A8, A10, A11, BA0, BA1 and All should stay "L" during mode set cycle.

POWER ON SEQUENCE

1. With inputs in NOP state, turn on the power supply and enter the system clock.
2. After the Vcc voltage has reached the specified level, take a pause of 200 μ s or more with the input being NOP.
3. Enter the precharge all bank command.
4. Apply CBR auto-refresh eight or more times.
5. Enter the mode register setting command.

AC CHARACTERISTIC

(V_{CC} = 3.3V ± 0.3V, T_a = 0 ~70°C)

NOTE 1, 2

| Parameter | | Symbol | Module Spec. | | Unit | Note |
|--|------|-------------------|-----------------------|---------|-------|------|
| | | | Min. | Max. | | |
| Clock Cycle Time | CL=3 | t _{CC} | 10 | - | ns | |
| | CL=2 | | 15 | - | ns | |
| Access Time from Clock | CL=3 | t _{AC} | - | 9 | ns | 3, 4 |
| | CL=2 | | - | 9 | ns | 3, 4 |
| Clock "H" Pulse Time | | t _{CH} | 3 | - | ns | |
| Clock "L" Pulse Time | | t _{CL} | 3 | - | ns | |
| Input Setup Time | | t _{SI} | 3 | - | ns | |
| Input Hold Time | | t _{HI} | 1 | - | ns | |
| Output Low Impedance Time from Clock | | t _{OLZ} | 3 | - | ns | |
| Output High Impedance Time from Clock | | t _{OHZ} | - | 8 | ns | |
| Output Hold from Clock | | t _{OH} | 3 | - | ns | 3 |
| /RAS Cycle Time | | t _{RC} | 90 | - | ns | |
| /RAS Precharge Time | | t _{RP} | 30 | - | ns | |
| /RAS Active Time | | t _{RA} | 60 | 100,000 | ns | |
| /RAS to /CAS Delay Time | | t _{RCD} | 30 | - | ns | |
| Write Recovery Time | | t _{WR} | 15 | - | ns | |
| /RAS to /RAS Bank Active Delay Time | | t _{RRD} | 20 | - | ns | |
| Refresh Time | | t _{REF} | - | 64 | ms | |
| Power-down Exit Set-up Time | | t _{PDE} | t _{SI} +1CLK | - | ns | |
| Input Level Transition Time | | t _T | - | 3 | ns | |
| /CAS to /CAS Delay Time (Min) | | t _{CCD} | 1 | | Cycle | |
| Clock Disable Time from CKE | | t _{CKE} | 1 | | Cycle | |
| Data Output High Impedance Time from DQMB | | t _{DOZ} | 2 | | Cycle | |
| Data Input Mask Time from DQMB | | t _{IDOD} | 0 | | Cycle | |
| Data Input Time from Write Command | | t _{IDWD} | 0 | | Cycle | |
| Data Output High Impedance Time from Precharge Command | | t _{IROH} | 2 | | Cycle | |
| Active Command Input Time from MODE Register Set Command Input (Min) | | t _{IMRD} | 3 | | Cycle | |
| Write Command Input Time from Output | | t _{IOWD} | 2 | | Cycle | |

NOTES:

- 1) AC measurements assume t_T=1ns.
- 2) The reference level for timing of input signals is 1.4V.
- 3) This parameter is measured with a load circuit equivalent to 1 TTL load and 50pF (R_{Load} is 50ohm).
- 4) An access time is measured at 1.4V.
- 5) If t_T is longer than 1ns, the reference level for timing of input signals are V_{IH} and V_{IL}.

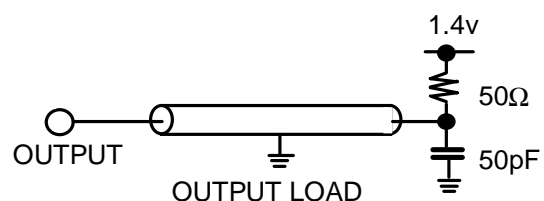

FUNCTION TRUTH TABLE (Table1) (1/2)

| Current State | /CS | /RAS | /CAS | /WE | BA | ADDR | Action |
|---------------------------|-----|------|------|-----|----|---------|---|
| Idle | H | X | X | X | X | X | NOP |
| | L | H | H | H | X | X | NOP |
| | L | H | H | L | BA | X | ILLEGAL ² |
| | L | H | L | X | BA | CA | ILLEGAL ² |
| | L | L | H | H | BA | RA | Row Active |
| | L | L | H | L | BA | A10 | NOP ⁴ |
| | L | L | L | H | X | X | Auto-Refresh or Self-Refresh ⁵ |
| | L | L | L | L | L | OP Code | Mode Register write |
| Row Active | H | X | X | X | X | X | NOP |
| | L | H | H | X | X | X | NOP |
| | L | H | L | H | BA | CA, A10 | Read |
| | L | H | L | L | BA | CA, A10 | Write |
| | L | L | H | H | BA | RA | ILLEGAL ² |
| | L | L | H | L | BA | A10 | Precharge |
| | L | L | L | X | X | X | ILLEGAL |
| Read | H | X | X | X | X | X | NOP (Continue Row Active after Burst ends) |
| | L | H | H | H | X | X | NOP (Continue Row Active after Burst ends) |
| | L | H | H | L | BA | X | Burst Stop |
| | L | H | L | H | BA | CA, A10 | Term Burst, start new Burst Read ³ |
| | L | H | L | L | BA | CA, A10 | Term Burst, start new Burst Write ³ |
| | L | L | H | H | BA | RA | ILLEGAL ² |
| | L | L | H | L | BA | A10 | Term Burst, execute Row Precharge |
| | L | L | L | X | X | X | ILLEGAL |
| Write | H | X | X | X | X | X | NOP (Continue Row Active after Burst ends) |
| | L | H | H | H | X | X | NOP (Continue Row Active after Burst ends) |
| | L | H | H | L | BA | X | Burst Stop |
| | L | H | L | H | BA | CA, A10 | Term Burst, start new Burst Read ³ |
| | L | H | L | L | BA | CA, A10 | Term Burst, start new Burst Write ³ |
| | L | L | H | H | BA | RA | ILLEGAL ² |
| | L | L | H | L | BA | A10 | Term Burst, execute Row Precharge ³ |
| | L | L | L | X | X | X | ILLEGAL |
| Read with Auto Precharge | H | X | X | X | X | X | NOP (Continue Burst to End and enter Row Precharge) |
| | L | H | H | H | X | X | NOP (Continue Burst to End and enter Row Precharge) |
| | L | H | H | L | BA | X | ILLEGAL ² |
| | L | H | L | H | BA | CA, A10 | ILLEGAL ² |
| | L | H | L | L | X | X | ILLEGAL |
| | L | L | H | X | BA | RA, A10 | ILLEGAL ² |
| | L | L | L | X | X | X | ILLEGAL |
| Write with Auto Precharge | H | X | X | X | X | X | NOP (Continue Burst to End and enter Row Precharge) |
| | L | H | H | H | X | X | NOP (Continue Burst to End and enter Row Precharge) |
| | L | H | H | L | BA | X | ILLEGAL ² |
| | L | H | L | H | BA | CA, A10 | ILLEGAL ² |
| | L | H | L | L | X | X | ILLEGAL |
| | L | L | H | X | BA | RA, A10 | ILLEGAL ² |
| | L | L | L | X | X | X | ILLEGAL |

FUNCTION TRUTH TABLE (Table1) (2/2)

| Current State | /CS | /RAS | /CAS | /WE | BA | ADDR | Action |
|----------------------|-----|------|------|-----|----|------|---------------------------|
| Precharge | H | X | X | X | X | X | NOP → Idle after tRP |
| | L | H | H | H | X | X | NOP → Idle after tRP |
| | L | H | H | L | BA | X | ILLEGAL ² |
| | L | H | L | X | BA | CA | ILLEGAL ² |
| | L | L | H | H | BA | RA | ILLEGAL ² |
| | L | L | H | L | BA | A10 | NOP ⁴ |
| | L | L | L | X | X | X | ILLEGAL |
| Write Recovery | H | X | X | X | X | X | NOP |
| | L | H | H | H | X | X | NOP |
| | L | H | H | L | BA | X | ILLEGAL ² |
| | L | H | L | X | BA | CA | ILLEGAL ² |
| | L | L | H | H | BA | RA | ILLEGAL ² |
| | L | L | H | L | BA | A10 | ILLEGAL ² |
| | L | L | L | X | X | X | ILLEGAL |
| Row Active | H | X | X | X | X | X | NOP Row Active after tRCD |
| | L | H | H | H | X | X | NOP Row Active after tRCD |
| | L | H | H | L | BA | X | ILLEGAL ² |
| | L | H | L | X | BA | CA | ILLEGAL ² |
| | L | L | H | H | BA | RA | ILLEGAL ² |
| | L | L | H | L | BA | A10 | ILLEGAL ² |
| | L | L | L | X | X | X | ILLEGAL |
| Refresh | H | X | X | X | X | X | NOP → Idle after tRC |
| | L | H | H | X | X | X | NOP → Idle after tRC |
| | L | H | L | X | X | X | ILLEGAL |
| | L | L | H | X | X | X | ILLEGAL |
| | L | L | L | X | X | X | ILLEGAL |
| Auto Resister Access | H | X | X | X | X | X | NOP |
| | L | H | H | H | X | X | NOP |
| | L | H | H | L | X | X | ILLEGAL |
| | L | H | L | X | X | X | ILLEGAL |
| | L | L | X | X | X | X | ILLEGAL |

ABBREVIATIONS

RA = Row Address

BA = Bank Address

NOP = No Operation command

CA = Column Address

AP = Auto Precharge

Notes:

1. All inputs will be enabled when CKE is set high for at least 1 cycle prior to the inputs.
2. Illegal to bank in specified state, but may be legal in some cases depending on the state of bank selection.
3. Satisfy the timing of tCCD and tWR to prevent bus contention.
4. NOP to bank precharging or in idle state. Precharges activated bank by BA or A10.
5. Illegal if any bank is not idle.

FUNCTION TRUTH TABLE (CKE) (Table2)

| Current State (n) | CKEn-1 | CKEn | /CS | /RAS | /CAS | /WE | ADDR | Action |
|---|--------|------|-----|------|------|-----|------|--------------------------------|
| Self Refresh | H | X | X | X | X | X | X | INVALID |
| | L | H | H | X | X | X | X | Exit Self Refresh → ABI |
| | L | H | L | H | H | H | X | Exit Self Refresh → ABI |
| | L | H | L | H | H | L | X | ILLEGAL |
| | L | H | L | H | L | X | X | ILLEGAL |
| | L | H | L | L | X | X | X | ILLEGAL |
| | L | L | X | X | X | X | X | NOP(Maintain Self Refresh) |
| Power Down | H | X | X | X | X | X | X | INVALID |
| | L | H | H | X | X | X | X | Exit Power Down → ABI |
| | L | H | L | H | H | H | X | Exit Power Down → ABI |
| | L | H | L | H | H | L | X | ILLEGAL |
| | L | H | L | H | L | X | X | ILLEGAL |
| | L | H | L | X | X | X | X | ILLEGAL ⁶ |
| | L | L | X | X | X | X | X | NOP (Continue power down mode) |
| All Banks idle ⁶ (ABI) | H | H | X | X | X | X | X | Refer to Table 1 |
| | H | L | H | X | X | X | X | Enter Power Down |
| | H | L | L | H | H | H | X | Enter Power Down |
| | H | L | L | H | H | L | X | ILLEGAL |
| | H | L | L | H | L | X | X | ILLEGAL |
| | H | L | L | L | H | L | X | ILLEGAL |
| | H | L | L | L | L | H | X | Enter Self Refresh |
| | L | L | L | L | L | L | X | ILLEGAL |
| Any State Other than Listed Above | L | L | X | X | X | X | X | NOP |
| | H | H | X | X | X | X | X | Refer to Operations in Table 1 |
| | H | L | X | X | X | X | X | Begin Clock Suspend Next Cycle |
| | L | H | X | X | X | X | X | Enable Clock of Next Cycle |
| | L | L | X | X | X | X | X | Continue Clock Suspension |

Notes:

6. Power-down and self refresh can be entered only when all the banks are in an idle state.