

CFPV-45, -46

ISSUE 2; 18 OCTOBER 2004

Delivery Options

- Please contact our sales office for current leadtimes

Description

- CFPV-45, -46 are surface mount voltage controlled crystal oscillators (VCXOs)

Package Outline

- 7.0 x 5.0 x 1.7mm SMD (surface mount device)

Output Compatibility

- Tri-state HCMOS/TTL
- Drive Capability: 15pF / 10LSTTL

Standard Frequency Stabilities

- ± 100 ppm (inclusive of frequency tolerance, ageing, shock and vibration)

Standard Operating Temperature Range

- 0 to 70°C

Operable Temperature Range

- -40 to 85°C

Storage Temperature Range

- -55 to 125°C

Voltage Control (pad 1)

- $1.65V \pm 1.65V$ (CFPV-45)
- $2.5V \pm 2.0V$ (CFPV-46)

Pullability

- ± 100 ppm min APR (positive)

Linearity

- $\leq \pm 10\%$

Modulation Bandwidth

- > 10 kHz

Tri-state Operation

- Logic '0' to pad 2 disables oscillator output; when disabled the oscillator output goes to the high impedance state
- No connection or Logic '1' to pad 2 enables oscillator output

Solder Conditions

- For typical soldering conditions, please see relevant pages in the Application Notes

Environmental Specification

- Mechanical shock per MIL-STD-202, Method 213, Cond. E.
- Thermal shock per MIL-STD-883, Method 1011, Cond. A
- Vibration per MIL-STD-883, Method 2007, Cond. A.

Marking

- Model number
- Frequency

Minimum Order Information Required

- Frequency + Model Number

Outline in mm

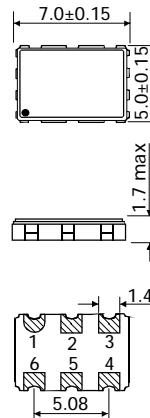

- Pad Connections
1. Voltage Control
 2. Enable / Disable
 3. GND
 4. Output
 5. N/C
 6. +Vs

Solder pad layout

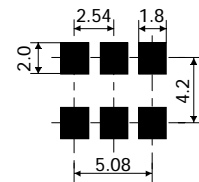

Output Waveform - HCMOS/TTL

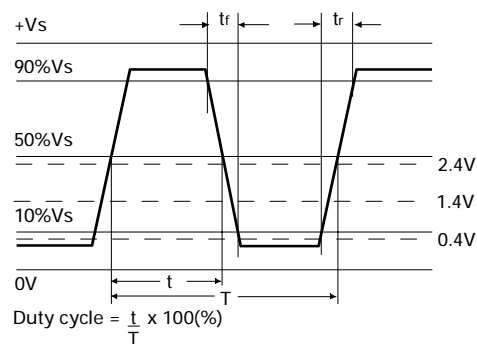

Electrical Specifications - maximum limiting values when measured in test circuit.

Frequency Range	Pullability APR	Supply Voltage	Supply Current	Rise Time(t_r)	Fall Time(t_f)	Duty Cycle	Model Number
1.5 to 50.0MHz	± 100 ppm min	3.3V ± 0.3 V	50mA	10ns	10ns	40/60%	CFPV-45
1.5 to 50.0MHz	± 100 ppm min	5.0V ± 0.5 V	60mA	10ns	10ns	40/60%	CFPV-46
Ordering Example				13.0MHz	CFPV-45		
Frequency _____							
Model number _____							

APR - Absolute Pulling Range

The APR is the minimum pulling from nominal after an allowance is made for frequency shift due to temperature, ageing, supply voltage and load variation plus environmental effects.

Note. For other frequencies / specifications please contact our sales office.
For operation over -40 to 85°C, please discuss your requirements with our sales office.

Test Circuit

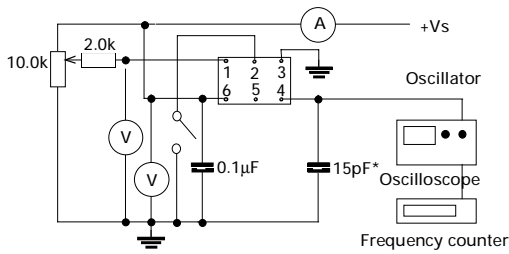

*Inclusive of jigging & equipment capacitance

Outline in mm - Tape

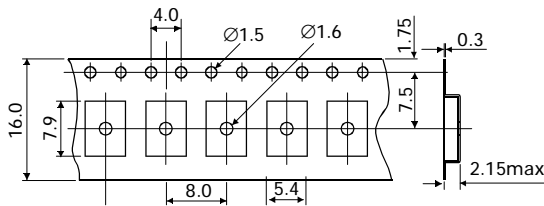

Outline in mm - Reel

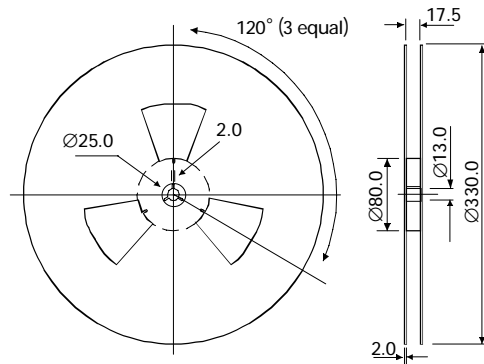

SURFACE MOUNT
VCKX0s