

Non-Volatile Digital Potentiometers With Up/Down (3-Wire) Interface, 10kΩ, 50kΩ, 100kΩ Resistance, 16 Taps With/Without Output Buffer



The iPot™ ISL45001, ISL45002 DCPs are single channel 16-tap non-volatile linear digital potentiometers available in 10kΩ, 50kΩ and 100kΩ resistance. The device consists of Up/Down serial interface, tap register, decoder, resistor array, wiper switches, NV memory and control logics.

The ISL45002 device can be configured as a two-terminal variable resistor or a three-terminal voltage divider without an output buffer, but the ISL45001 device, which has a built-in output buffer, can only be configured as a three-terminal voltage divider. Both devices can be used in a wide variety of applications.

The output of the potentiometer is determined by its wiper position, which varies linearly between its end terminals, R_A/V_A and R_B/V_B . The wiper position, R_W/V_W , is controlled by Up/Down serial interface (\overline{CS} , \overline{INC} and U/\overline{D}) through the Tap Register (TR). In addition, the wiper position can also be stored into a non-volatile memory location (NVMEM0), which is then automatically recalled upon power up.

Features

- Drop-in replacement for many popular parts
- Single linear-taper channel
- 16 taps
- 10K, 50K and 100K end-to-end resistance
- V_{SS} to V_{DD} terminal voltages
- Automatic recall of wiper position when power-on
- Potentiometer control through Up/Down (3-wire) serial interface
- Endurance 100,000 cycles
- Data retention 100 years
- Package options:
 - 8-pin PDIP, SOIC or MSOP
- Industrial temperature range: -40°C to 85°C
- Single supply operation: 2.7V to 5.5V

Ordering Information

OUTPUT BUFFER	END-TO-END RESISTANCE	SOIC	PDIP	MSOP	TEMP. RANGE (°C)
No	10K	ISL45002IB01	ISL45002IP01	ISL45002IU01	-40 to 85
	50K	ISL45002IB05	ISL45002IP05	ISL45002IU05	-40 to 85
	100K	ISL45002IB10	ISL45002IP10	ISL45002IU10	-40 to 85
Yes	10K	ISL45001IB01	ISL45001IP01	ISL45001IU01	-40 to 85
	50K	ISL45001IB05	ISL45001IP05	ISL45001IU05	-40 to 85
	100K	ISL45001IB10	ISL45001IP10	ISL45001IU10	-40 to 85

Pinouts

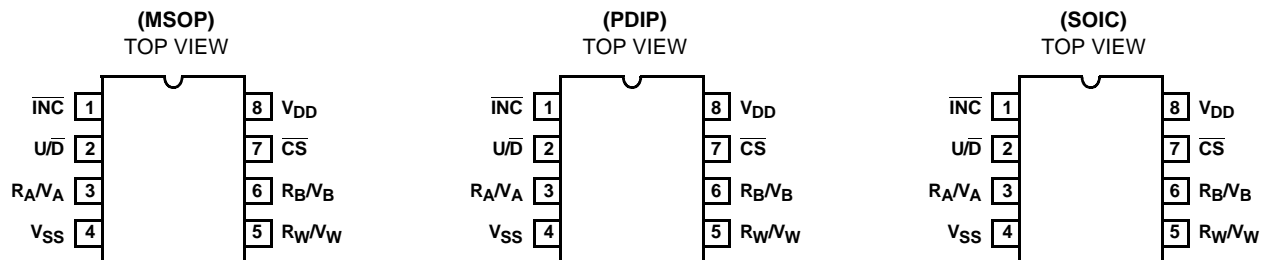

Pin Description

PIN NAME	DESCRIPTION
\overline{CS}	Chip Select: When \overline{CS} is LOW, the device is enabled. When \overline{CS} is HIGH, the part is deselected and is in standby mode
U/\overline{D}	Up/Down Control: HIGH state enables the wiper to move towards the R_A/V_A terminal, while LOW state implies the wiper moves towards the R_B/V_B terminal
\overline{INC}	Increment Control: When \overline{CS} is LOW, a HIGH-LOW transition on \overline{INC} will move the wiper one increment either up or down based on the U/\overline{D} input
R_A/V_A	High terminal of the device
R_B/V_B	Low terminal of the device
R_W/V_W	Wiper Terminal: Output of the resistor array is determined by the \overline{INC} , U/\overline{D} and \overline{CS} inputs
V_{SS}	Ground pin, logic ground reference
V_{DD}	Power Supply

NOTE: The terminology of high and low terminals above references to the relative position of the terminal with respect to the wiper moving direction and not the voltage potential of the terminal.

Block Diagrams

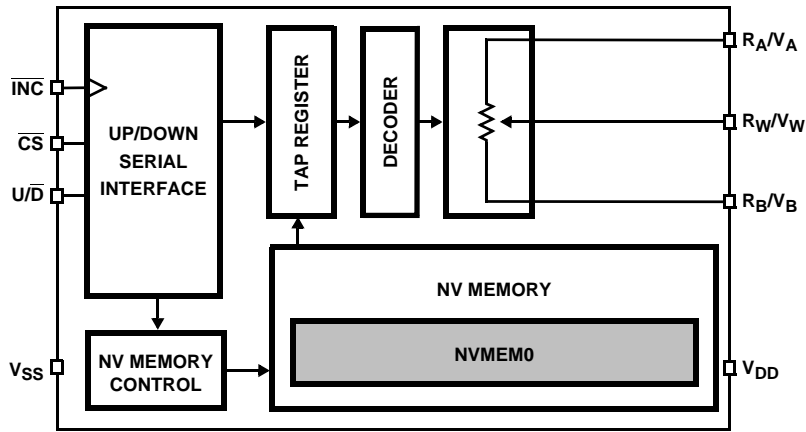

FIGURE 1. ISL45002 BLOCK DIAGRAM (RHEOSTAT/DIVIDER MODE)

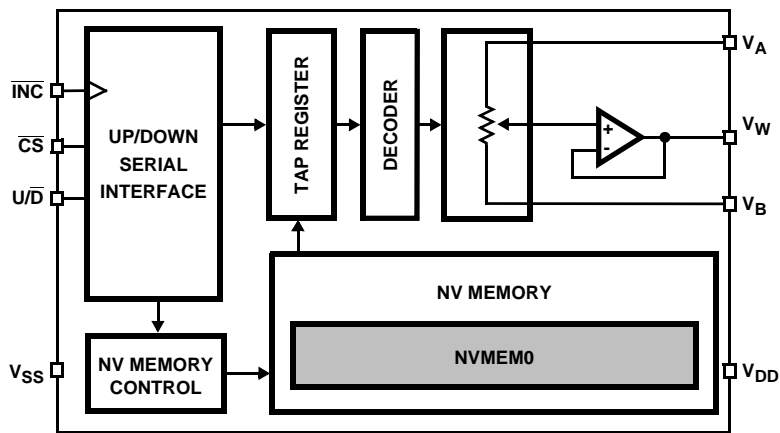

FIGURE 2. ISL45001 BLOCK DIAGRAM (DIVIDER MODE)

ISL45001, ISL45002

Absolute Maximum Ratings

Voltage Applied to Any Pad ($V_{SS} - 0.3V$) to ($V_{DD} + 0.3V$)
 $V_{SS} - V_{DD}$ -0.3 to 7.0V

Operating Conditions

Industrial Operating Temperature -40°C to +85°C
 Supply Voltage (V_{DD}) +2.7V to +5.5V
 Ground Voltage (V_{SS}) 0V

Thermal Information

Thermal Resistance (Typical) θ_{JA} (0m/s air velocity)

MSOP Package	130
PDIP Package	120
SOIC Package	160
Maximum Junction Temperature (Plastic Package)	150°C
Maximum Storage Temperature Range	-65°C to 150°C
Maximum Lead Temperature (Soldering 10s)	235°C (SOIC, Lead Tips Only)

CAUTION: Stresses above those listed in "Absolute Maximum Ratings" may cause permanent damage to the device. This is a stress only rating and operation of the device at these or any other conditions above those indicated in the operational sections of this specification is not implied.

Electrical Specifications Packaged parts.

PARAMETERS	SYMBOL	CONDITIONS (NOTE 5)	MIN	TYP	MAX	UNITS
RHEOSTAT MODE						
Nominal Resistance	R	T = 25°C, Wiper open	-20		+20	%
Different Non Linearity (Note 2)	R-DNL	(Note 6)	-1	±0.2	+1	LSB
Integral Non Linearity (Note 2)	R-INL	(Note 6)	-1	±0.4	+1	LSB
Tempo (Note 1)	$\Delta R_{AB}/\Delta T$			200		ppm/°C
Wiper Resistance (Note 2)	R_W	$V_{DD} = 5V, I = V_{DD}/R_{Total}$ (Note 7)		50		Ω
		$V_{DD} = 2.7V, I = V_{DD}/R_{Total}$ (Note 7)		80		Ω
Wiper Current	I_W		-1		1	mA
DIVIDER MODE						
Resolution	N		4			Bits
Different Non Linearity (Note 2)	DNL		-1	±0.2	+1	LSB
Integral Non Linearity (Note 2)	INL		-1	±0.2	+1	LSB
Temperature Coefficient (Note 1)	$\Delta W/\Delta T$	Wiper at center		+20		ppm/°C
Full Scale Error	V_{FSE}	Wiper at highest position	-1		0	LSB
Zero Scale Error	V_{ZSE}	Wiper at lowest position	0		1	LSB
RESISTOR TERMINAL						
Voltage Range	V_A, V_B, V_W		V_{SS}		V_{DD}	V
Terminal Capacitance (Note 1)	C_A, C_B			30		pF
Wiper Capacitance (Note 1)				30		pF
DYNAMIC CHARACTERISTICS (Note 1)						
Bandwidth -3dB	BW_{10K}	$V_{DD} = 5V, B = V_{SS}$ Wiper at center		1.5		MHz
	BW_{50K}			300		kHz
	BW_{100K}			200		kHz
ANALOG OUTPUT (Buffer Enables)						
Amp Output Current	I_{OUT}	$V_O = 1/2$ scale	3			mA
Amp Output Resistance	R_{out}	$I_L = 100\mu A$		1	10	Ω
Total Harmonic Distortion (Note 1)	THD	$A = 2.5V, V_{DD} = 5V, f = 1kHz, V_{IN} = 1V_{RMS}$			0.08	%

ISL45001, ISL45002

Electrical Specifications Packaged parts. (Continued)

PARAMETERS	SYMBOL	CONDITIONS (NOTE 5)	MIN	TYP	MAX	UNITS
DIGITAL INPUTS/OUTPUTS						
Input High Voltage	V_{IH}		$0.7 \times V_{DD}$			V
Input Low Voltage	V_{IL}				$0.3 \times V_{DD}$	V
Output Low Voltage	V_{OL}	$I_{OL} = 2\text{mA}$			0.4	V
Input Leakage Current	I_{LI}	$\overline{CS} = V_{DD}, V_{in} = V_{SS} \sim V_{DD}$	-1		+1	μA
Output Leakage Current	I_{Lo}	$\overline{CS} = V_{DD}, V_{in} = V_{SS} \sim V_{DD}$	-1		+1	μA
Input Capacitance (Note 1)	C_{IN}	$V_{DD} = 5\text{V}, f_c = 1\text{MHz}$		25		pF
Output Capacitance (Note 1)	C_{OUT}	$V_{DD} = 5\text{V}, f_c = 1\text{MHz}$		25		pF
POWER REQUIREMENTS						
Operating Voltage	V_{DD}		2.7		5.5	V
Operating Current	I_{DDR}, I_{DDW}	All operations		1	2	mA
Standby Current	I_{SA} (Note 3)	Buffer = ON $\overline{CS} = \text{HIGH}$, no load		0.5	1	mA
	I_{SB} (Note 4)	Buffer = OFF $\overline{CS} = \text{HIGH}$, no load		0.1	1	μA
Power Supply Rejection Ratio	PSRR	$V_{DD} = 5\text{V} \pm 10\%$, Wiper at center			1	LSB/V

NOTES:

1. Not subject to production test.
2. $LSB = (R_A/V_A - R_B/V_B)/(T - 1)$; $DNL = (V_i - V_{i+1})/LSB + 1$ (if increment) or $(V_i - V_{i+1})/LSB - 1$ (if decrement); $INL = (V_i - i \cdot LSB)/LSB$; where $i = [0, (T - 1)]$ and $T = \#$ of taps of the device.
3. ISL45001 only.
4. ISL45002 only.
5. Conditions: $V_{CC} = 2.7$ to 5.5V , $T = 25^\circ\text{C}$ and timing measured at 50% level, unless stated.
6. Only guarantee by design.
7. R_{Total} = end-to-end resistance.

Functional Description

Rheostat and Divider Operations

The ISL45002 device can operate as either a two-terminal variable resistor or a three-terminal voltage divider without an output buffer. However, the ISL45001 can only operate in a three-terminal voltage divider with an output buffer.

RHEOSTAT CONFIGURATION

In the rheostat mode, the ISL45002 can be configured as a two-terminal resistive element, where one terminal is connected to one end of the resistor (R_A or R_B) and the other terminal is the wiper (R_W). The moving direction of the wiper depends upon the setting of U/\bar{D} control signal. When the U/\bar{D} is set to Up, then the wiper moves towards R_A . Conversely, when the U/\bar{D} is set to Down, then the wiper moves towards R_B . The wiper movement to either direction is controlled by toggling the \overline{INC} signal from HIGH to LOW.

This configuration controls the resistance between the wiper and either end. The wiper resistance can be adjusted by either changing the wiper position or loading a stored wiper position value from NVMEM0 upon power up.

DIVIDER CONFIGURATION

Additionally, the ISL45002 can also be configured as a voltage divider. With an input voltage applied to one end (usually V_A), the ground is connected to the other end (usually V_B). These input voltages cannot exceed the V_{DD} level or go below the V_{SS} level. The voltage on the wiper, V_W , is proportional to the wiper position with respect to the voltage difference between V_A and V_B . The moving direction of the wiper depends upon the setting of the U/\bar{D} control signal. When the U/\bar{D} is set to Up, then the wiper moves towards V_A . Conversely, when the U/\bar{D} is set to Down, then the wiper moves towards V_B . The wiper movement to either direction is controlled by toggling the \overline{INC} signal from HIGH to LOW.

Nevertheless, the ISL45001 can only be configured as a voltage divider and operate similarly as the ISL45002 device. The only difference is ISL45001 has an output buffer, but ISL45002 does not.

Besides, the resistance cannot be directly measured in this configuration.

Non-Volatile Memory (NVMEM0)

The ISL45001, ISL45002 has one NVMEM0 location available for storing the current wiper position via the Up/Down serial interface. This stored value is automatically recalled and loaded into the tap register upon power up.

Serial Data Interface

The ISL45001, ISL45002 device has a 3-wire Up/Down Serial Interface consisting of \overline{CS} , \overline{INC} and U/\bar{D} control signals. The key features of this interface include:

- Enabling the device
- Determining the moving direction of the wiper
- Increment/Decrement operation on the wiper
- Non-volatile storage of the present wiper position into the NVMEM0 for automatic recall at power up
- Entering into the standby mode

Operation Overview

The wiper position can be changed either up or down by operating the \overline{CS} , U/\bar{D} and \overline{INC} control signals.

When \overline{CS} is LOW, the device is selected and the wiper can be moved by toggling the \overline{INC} . As a result, the wiper moves up when U/\bar{D} is HIGH and moves down when U/\bar{D} is LOW. The status of the U/\bar{D} can be changed even though the \overline{CS} remains LOW. This allows the system to enable the device and then move the wiper position either up or down until the desired position is reached.

When the wiper is already at the lowest position, further Down operation won't change the wiper position. Similarly, when the wiper is at the highest position, further Up operation won't change the wiper position.

The current wiper position can be automatically stored into the NVMEM0 each time the \overline{CS} goes from LOW to HIGH while the \overline{INC} remains HIGH. Adversely, if the \overline{INC} is LOW when the \overline{CS} goes HIGH, the wiper position cannot be stored. Meanwhile, the NVMEM0 content is automatically loaded into the wiper during power on.

When the \overline{CS} is held HIGH, the device enters into Standby mode and the wiper position cannot be changed. Changing the \overline{CS} to LOW exits the Standby mode and enables the device again.

The operating modes of Up/Down interface are summarized in the table below:

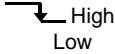
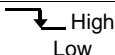
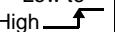
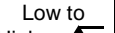
\overline{CS}	U/\bar{D}	\overline{INC}	OPERATION
Low	High		Move Wiper toward R_A/V_A
Low	Low		Move Wiper toward R_B/V_B
Low to High 	x	High	Store Current Wiper Position
Low to High 	x	Low	No Store, Return to Standby
High	x	x	Standby

NOTE: x means don't care.

Timing Diagram $V_{DD} = +2.7V$ to $5.5V$, $V_A = V_{DD}$, $V_B = 0V$, $T = 25^\circ C$

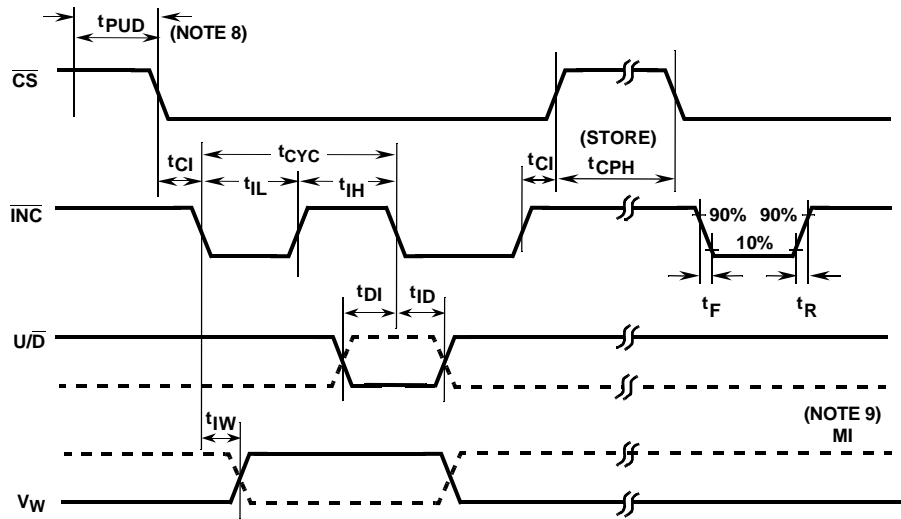

FIGURE 3. ISL45001, ISL45002 TIMING DIAGRAM

NOTES:

- 8. This only applies to the Power-Up sequence.
- 9. MI in the AC Timing diagram (Figure 3) refers to the minimum incremental change in the wiper output due to a change in the wiper position.

Timing Parameters

PARAMETERS	SYMBOL	MIN	MAX	UNITS
\overline{CS} to \overline{INC} Setup	t_{CI}	100		ns
$\overline{U/D}$ to \overline{INC} Setup	t_{DI}	50		ns
$\overline{U/D}$ to \overline{INC} Hold	t_{ID}	100		ns
\overline{INC} LOW Period	t_{IL}	250		ns
\overline{INC} HIGH Period	t_{IH}	250		ns
\overline{INC} Inactive to \overline{CS} Inactive	t_{IC}	1		μs
\overline{CS} Deselect Time (NO STORE)	t_{CPH}	100		ns
\overline{CS} Deselect Time (STORE)	t_{CPH}	15 (2.7V) 30 (5.5V)		ms
\overline{INC} to Wiper Change	t_{IW}		5	μs
\overline{INC} Cycle Time	t_{CYC}	1		μs
\overline{INC} Input Rise and Fall Time	t_R, t_F		500	μs
Power-Up Delay	t_{PUD}		1	ms
V_{CC} Power-Up Rate	$t_R V_{CC}$	0.2 (13ms, 0-2.7V)	50 (54 μs , 0-2.7V)	V/ms

Test Circuits

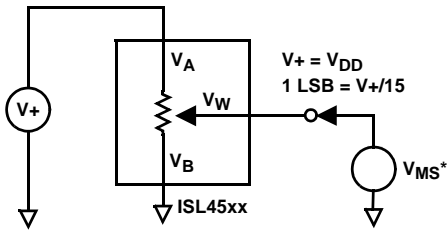

*Assume infinite input impedance

FIGURE 4. POTENTIOMETER DIVIDER NONLINEARITY ERROR TEST CIRCUIT (INL, DNL)

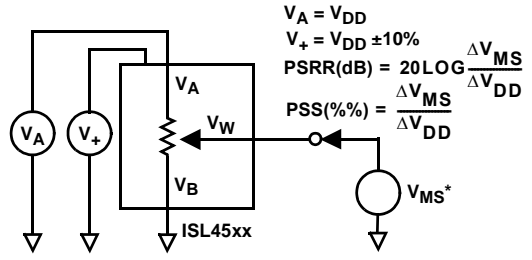

*Assume infinite input impedance

FIGURE 5. POWER SUPPLY SENSITIVITY TEST CIRCUIT (PSS, PSRR)

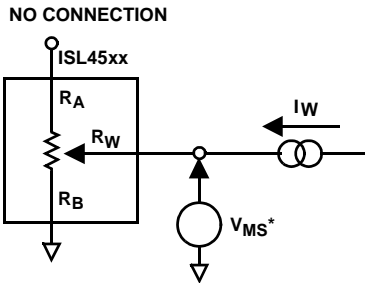

*Assume infinite input impedance

FIGURE 6. RESISTOR POSITION NONLINEARITY ERROR TEST CIRCUIT (RHEOSTAT OPERATION: R-INL, R-DNL)

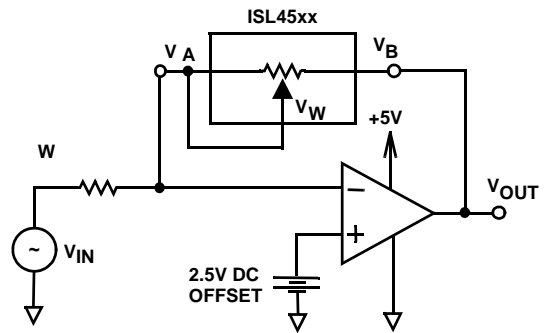
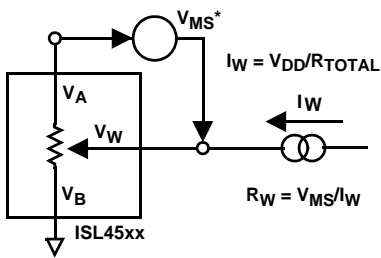

FIGURE 7. CAPACITANCE TEST CIRCUIT



*Assume infinite input impedance

FIGURE 8. WIPER RESISTANCE TEST CIRCUIT

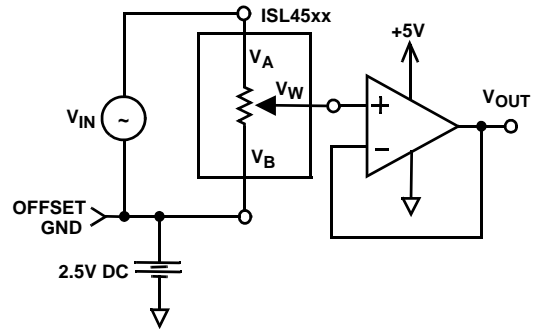
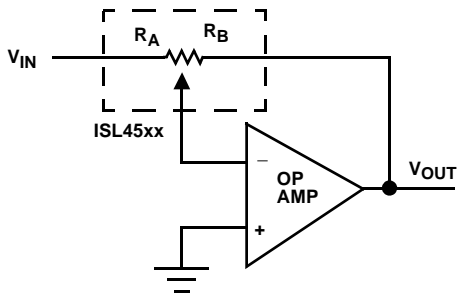

FIGURE 9. GAIN vs FREQUENCY TEST CIRCUIT

Typical Application Circuits



$$V_{OUT} = -V_{IN} \frac{R_B}{R_A}$$

$$R_A = \frac{R_{AB}(16-W)}{16}, R_B = \frac{R_{AB} \cdot W}{16}$$

R_{AB} = Total resistance of potentiometer.
 W = Wiper setting for ISL45xx

FIGURE 10. PROGRAMMABLE INVERTING GAIN AMPLIFIER USING THE ISL45001/ISL45002

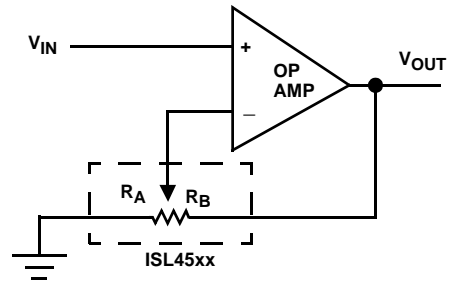

$$V_{OUT} = V_{IN} \left(1 + \frac{R_B}{R_A} \right)$$

$$R_A = \frac{R_{AB}(16-W)}{16}, R_B = \frac{R_{AB} \cdot W}{16}$$

R_{AB} = Total resistance of potentiometer.
 W = Wiper setting for ISL45xx

FIGURE 11. PROGRAMMABLE NON-INVERTING GAIN AMPLIFIER USING THE ISL45001/ISL45002

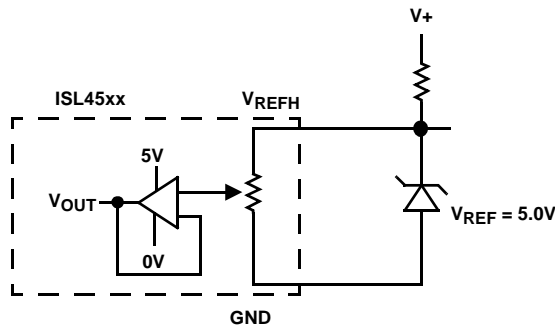

FIGURE 12. ISL45001 TRIMMING VOLTAGE REFERENCE

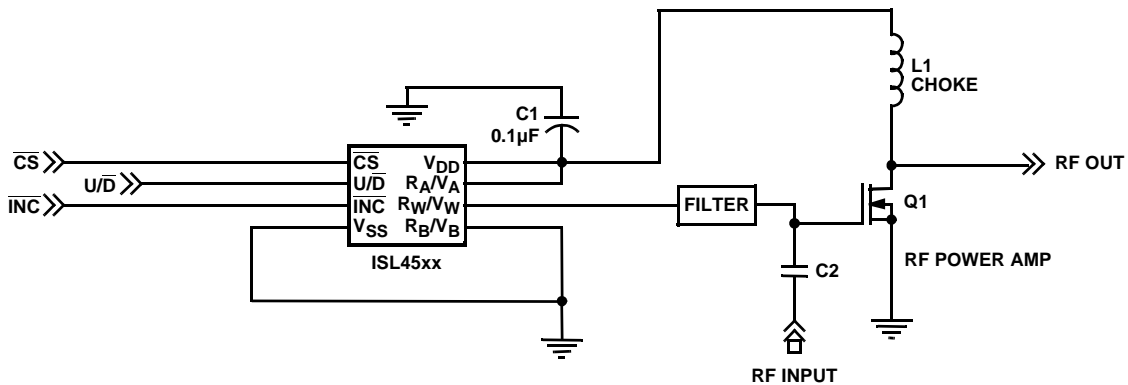

FIGURE 13. ISL45001 RF AMP CONTROL

Layout Considerations

Use a 0.1 μ F bypass capacitor as close as possible to the V_{DD} pin. This is recommended for best performance. Often this can be done by placing the surface mount capacitor on the bottom side of the PC board, directly between the V_{DD} and V_{SS} pins. Care should be taken to separate the analog

and digital traces. Sensitive traces should not run under the device or close to the bypass capacitors.

A dedicated plane for analog ground helps in reducing ground noise for sensitive analog signals.

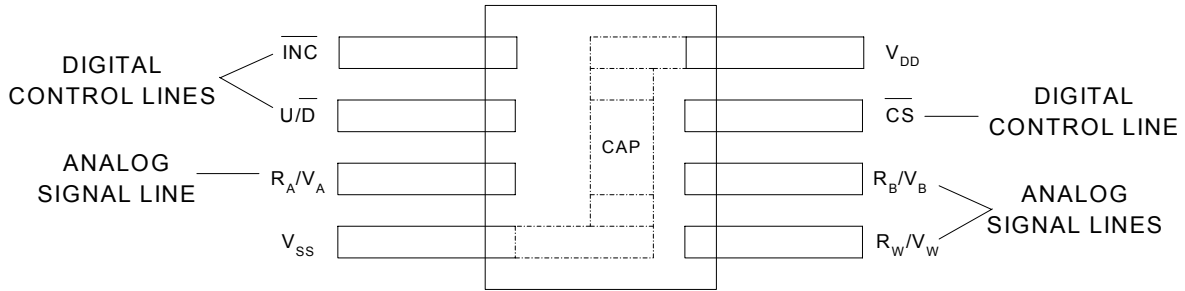
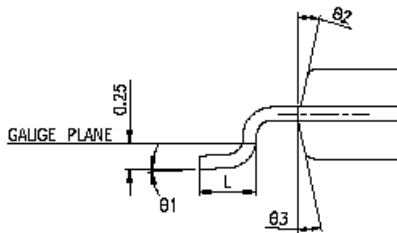
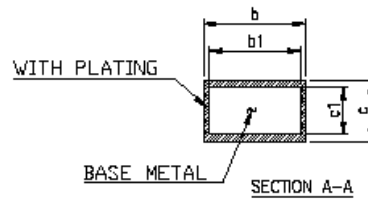
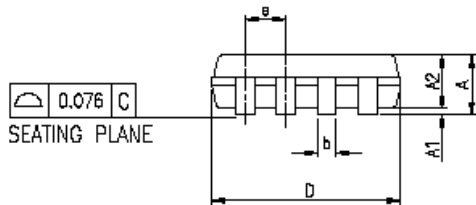
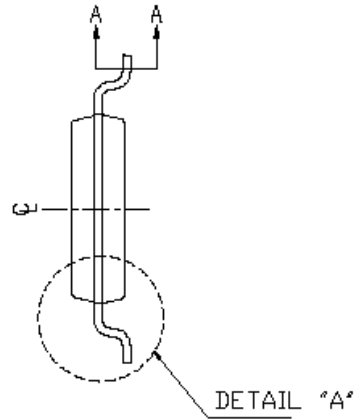
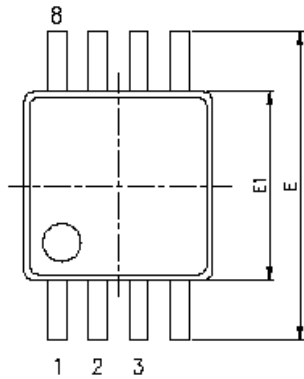

FIGURE 14. ISL45001, ISL45002 LAYOUT

Mini Small Outline Plastic Packages (MSOP)
8 Lead 3mm MSOP



DETAIL "A"
 SCALE 25:1

SYMBOL	DIMENSION IN MM			DIMENSION IN INCH		
	MIN.	NOM.	MAX.	MIN.	NOM.	MAX.
A	---	---	1.10	---	---	0.043
A1	0.05	---	0.15	0.002	---	0.006
A2	0.81	0.86	0.91	0.032	0.034	0.036
c	0.13	---	0.23	0.005	---	0.009
c1	0.13	0.15	0.18	0.005	0.006	0.007
D	2.90	3.00	3.10	0.114	0.118	0.122
E1	2.90	3.00	3.10	0.114	0.118	0.122
E	4.90 BSC			0.193 BSC		
L	0.445	0.55	0.648	0.0175	0.0217	0.0255
θ_1	0°		6°	0°		6°

SYMBOL	8L			1DL		
	MIN.	NOM.	MAX.	MIN.	NOM.	MAX.
b	0.25	---	0.40	0.17	---	0.27
b1	0.25	0.30	0.35	0.17	0.20	0.23
e	0.65 BSC			0.50 BSC		
JEDEC	MO-187AA			MO-187		

Dual-In-Line Plastic Packages (PDIP)

8 Lead 300MIL PDIP

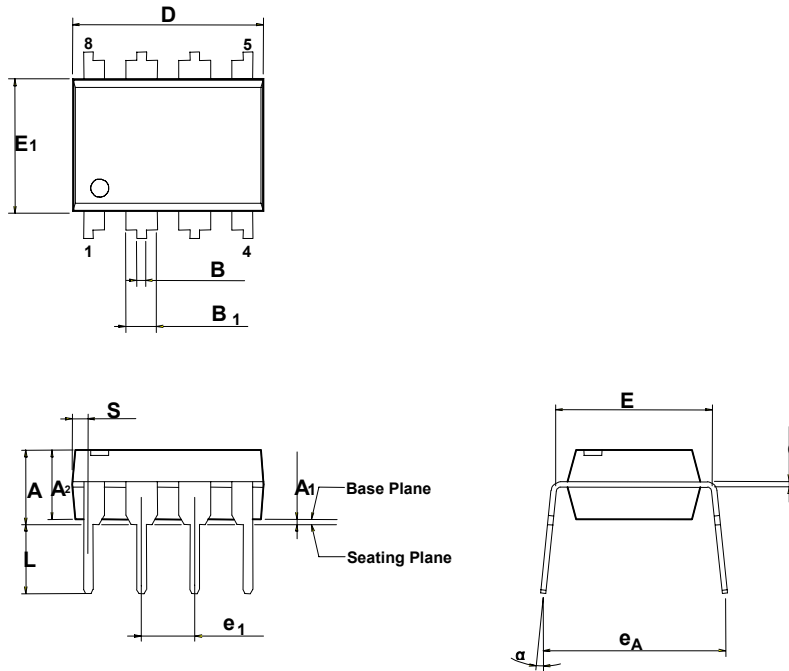

Symbol	Dimension in inch			Dimension in mm		
	Min	Nom	Max	Min	Nom	Max
A	—	—	0.175	—	—	4.45
A ₁	0.010	—	—	0.25	—	—
A ₂	0.125	0.130	0.135	3.18	3.30	3.43
B	0.016	0.018	0.022	0.41	0.46	0.56
B ₁	0.058	0.060	0.064	1.47	1.52	1.63
c	0.008	0.010	0.014	0.20	0.25	0.36
D	—	0.360	0.380	—	9.14	9.65
E	0.290	0.300	0.310	7.37	7.62	7.87
E ₁	0.245	0.250	0.255	6.22	6.35	6.48
e ₁	0.090	0.100	0.110	2.29	2.54	2.79
L	0.120	0.130	0.140	3.05	3.30	3.56
α	0	—	15	0	—	15
e _A	0.335	0.355	0.375	8.51	9.02	9.53
S	—	—	0.045	—	—	1.14

Small Outline Plastic Packages (SOIC)

8 Lead 150MIL SOIC

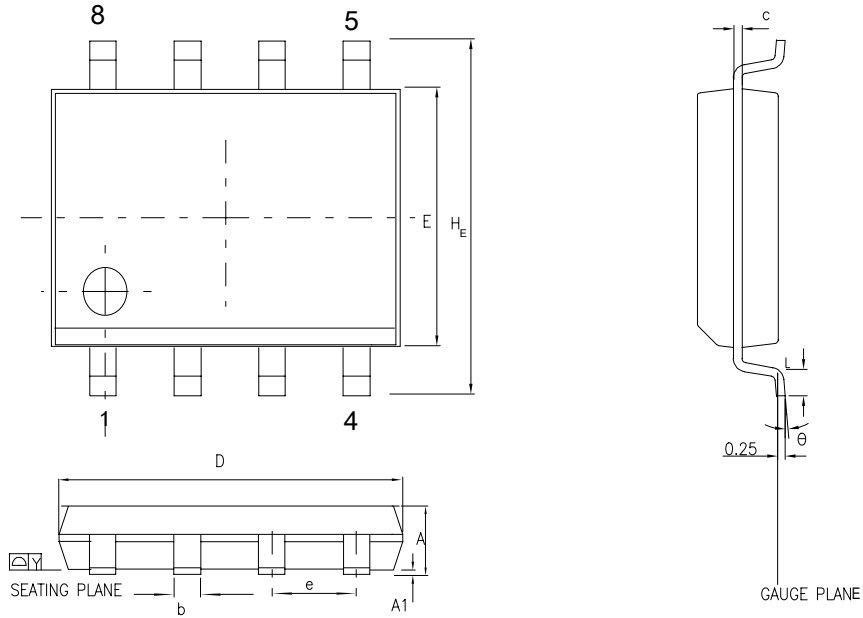

Control dimensions are in millimeters.

SYMBOL	DIMENSION IN MM		DIMENSION IN INCH	
	MIN.	MAX.	MIN.	MAX.
A	1.35	1.75	0.053	0.069
A1	0.10	0.25	0.004	0.010
b	0.33	0.51	0.013	0.020
c	0.19	0.25	0.008	0.010
E	3.80	4.00	0.150	0.157
D	4.80	5.00	0.188	0.196
e	1.27 BSC		0.050 BSC	
HE	5.80	6.20	0.228	0.244
Y	0.10		0.004	
L	0.40	1.27	0.016	0.050
θ	0	10	0	10

All Intersil U.S. products are manufactured, assembled and tested utilizing ISO9000 quality systems.

Intersil Corporation's quality certifications can be viewed at www.intersil.com/design/quality

Intersil products are sold by description only. Intersil Corporation reserves the right to make changes in circuit design, software and/or specifications at any time without notice. Accordingly, the reader is cautioned to verify that data sheets are current before placing orders. Information furnished by Intersil is believed to be accurate and reliable. However, no responsibility is assumed by Intersil or its subsidiaries for its use; nor for any infringements of patents or other rights of third parties which may result from its use. No license is granted by implication or otherwise under any patent or patent rights of Intersil or its subsidiaries.

For information regarding Intersil Corporation and its products, see www.intersil.com