

The TQ8034 is a non-blocking 34 X 34 digital crosspoint switch capable of data rates greater than 1.6 Gigabits per second per port. Utilizing a fully differential data path from input to output, the TQ8034 offers a high data rate with exceptional fidelity. The symmetrical switching and noise rejection characteristics inherent in differential logic result in low jitter, low crosstalk and minimum signal skew. The TQ8034 is ideally suited for gigabit data and HDTV switching applications.

The non-blocking architecture uses 34 fully independent 34:1 multiplexers, allowing each output port to be independently programmed to any input port. The TQ8034 supports full broadcast and multicast operation, with programming modes optimized for these applications.

Four methods are provided for configuration of the switch. Two modes are used for programming one input to one output at a time and the other two are for programming one input to multiple outputs (1 to 34) at once. In all modes, data integrity is maintained on all unchanged data paths.

TQ8034

PRELIMINARY DATA SHEET

1.6 Gbit/sec 3.3V 34x34 Digital Crosspoint Switch

Features

- >1.6 Gb/s port data bandwidth
>50 Gb/s aggregate bandwidth
- 3.3V power supply
- Fully differential data path for superior signal fidelity
- Non-blocking architecture
- Full broadcast and multi-cast capability
- Differential LVPECL I/O with TTL control
- On-chip 50 Ohm LVPECL input termination
- Low jitter and signal skew
- Two-stage configuration register
- Multiple programming modes
- 304-pin BGA package

Applications

- Telecom/datacom switching including Fibre Channel and Gigabit Ethernet
- Hubs and routers
- Video switching including High-Definition TV (HDTV)

Circuit Description

Data inputs

The 34 input channels are differential LVPECL compatible with on-chip 50-Ohm termination to VTT. Unused input-pairs should have one side connected to GND through a 500-Ohm or smaller resistor to prevent unwanted oscillations. See figure 6 for examples of DC and AC coupled termination.

Data outputs

The 34 output channels are differential LVPECL compatible and designed to be terminated through 50-Ohms to VDD-2.0V. Unused outputs can be left un-terminated to save power. See figure 6 for examples of DC and AC coupled termination.

Control Inputs

The control inputs are TTL compatible. Unconnected inputs will default to logic HI levels.

Configuration Storage

Each of the 34 output channels has two sets of configuration storage registers. The registers are built using transparent latches which are controlled by the LOAD and CONFIGURE inputs. The first set of latches, or program register, stores a new input configuration prior to application to the switch core. The second set of latches, or configuration register, stores the configuration that is applied to the switch core. The use of two sets of program storage latches allows new configurations to be loaded without disturbing the existing configuration. The two-stage architecture also allows all of the new configurations to be applied to the switch core simultaneously.

Configuration Modes

There are two primary modes for configuring the TQ8034; Sequential and Multicast. Sequential mode is used to program one input to one output per LOAD cycle and Multicast is used to program one input to multiple outputs per LOAD cycle. Both modes allow either a user defined input port assignment or an internal default input port assignment.

The default input port assignment for each output port is the output's corresponding input port (IN0 to OUT0, IN1 to OUT1, etc.). This default configuration is referred to as pass-through.

All programming modes result in the loading of a new configuration into the appropriate output port PROGRAM (first stage) registers. Changing the contents of the PROGRAM registers does not change the configuration of the switch core. The configuration of the switch core is updated following the assertion of CONFIGURE. CONFIGURE is a global input that simultaneously transfers the contents of all PROGRAM registers into their second stage CONFIGURATION registers. The data is latched into the CONFIGURATION register when CONFIGURE is de-asserted.

The integrity of the data flowing through the switch core is maintained during the load cycle. The integrity of the data flowing through the switch core to outputs that do not receive a new configuration is also maintained during the configure cycle. Data integrity is unknown on output ports receiving a new input port configuration for a time T_{dcf} after assertion of CONFIGURE (see timing diagrams).

The CONFIGURE inputs can be tied to a "HI" level or asserted simultaneously with LOAD. In this case, the new configuration will be applied to the switch multiplexer when LOAD is asserted.

The configuration modes are defined by the MODE0 and MODE1 control inputs.

MODE0	MODE1	Switch Configuration Mode
0	0	Sequential Mode: User defined input port assignment
0	1	Sequential Mode: Default input port assignment
1	0	Multicast Mode: User defined input port assignment
1	1	Multicast Mode: Default input port assignment

Sequential Program Mode

Sequential programming allows for a single input to output port assignment per LOAD cycle. Any number of port assignments can be made with repeated LOAD cycles prior to assertion of CONFIGURE.

User defined input port assignment (MODE0=0, MODE1=0)

User defined input port assignment Sequential programming uses the address inputs IADD(0:5) and the lower 6 bits of OADD(0:33).

To program, apply the desired output port address to the address inputs OADD(0:5) and the desired input port address to the address inputs IADD(0:5). The input address defines which input port connects to the selected output port. The new configuration is loaded into the PROGRAM register by asserting the LOAD input high and is latched when LOAD is de-asserted.

Default input port assignment (MODE0=0, MODE1=1)

Default input port assignment Sequential programming uses the same lower 6 bits of OADD(0:33) and ignores the IADD(0:5) inputs.

To program, apply the desired output port address to the address inputs OADD(0:5). The default

configuration is loaded into the PROGRAM register by asserting the LOAD input high and is latched when LOAD is de-asserted.

Multicast Program Mode

Multicast programming allows any combination of output ports to be configured to a single input port in a single LOAD cycle.

User defined input port assignment (MODE0=1, MODE1=0)

User defined input port assignment Multicast programming uses input addresses IADD(0:5) and output addresses OADD(0:33).

To program, apply the desired input port address to IADD(0:5) and the OADD(0:33) bits which correspond to the desired output ports. For example, to program input 1 to output ports 1, 2 and 5; apply "000001" to IADD(0:5) and apply "00..0100110" to OADD(0:33). The new configuration is loaded into the program latches by asserting the LOAD signal high and is latched when LOAD is de-asserted. This process is continued for each set of outputs to be programmed to a unique input. Data is then transferred to the CONFIGURATION latches upon assertion of CONFIGURE input.

Default input port assignment (MODE0=1, MODE1=1)

Default input port assignment Multicast programming uses the OADD(0:33) inputs and ignores the IADD(05) inputs. Apply the desired output ports to be configured to inputs OADD(0:33). Upon assertion of LOAD, each output port selected will be programmed to its corresponding input port.

Specifications

Specifications subject to change without notice

Table 1. Absolute Maximum Ratings⁴

Parameter	Condition	Symbol	Minimum	Nominal	Maximum	Unit
Storage Temperature		T_{store}	-65		150	°C
Junction Temperature		T_{CH}	-65		150	°C
Case Temperature w/bias	(1)	T_C	0		100	°C
Supply Voltage	(2)	V_{DD}	0		5.5	V
Voltage to any input	(2)	V_{in}	-0.5		$V_{DD} + 0.5$	V
Voltage to any output	(2)	V_{out}	-0.5		$V_{DD} + 0.5$	V
Current to any TTL input	(2)	I_{in}	-1.0		1.0	mA
Current from any output	(2)	I_{out}			40.0	mA
Power Dissipation of output	(3)	P_{out}			50.0	mW
Electrostatic Discharge		ESD			2000	V

Notes: 1. T_C is measured at case top.

2. All voltages are measured with respect to GND (0V) and are continuous.

3. $P_{out} = (V_{DD} - V_{out}) \times I_{out}$.

4. Absolute maximum ratings, as detailed in this table, are the ratings beyond which the device's performance may be impaired and/or permanent damage to the device may occur.

Table 2. Recommended Operating Conditions⁷

Symbol	Parameter	Min	Typ	Max	Units	Notes
T_C	Case Operating Temperature	0	—	100	°C	1
V_{DD}	Supply Voltage	3.14	—	3.47	V	
I_{DDcore}	Positive Supply Current Switch Core		2.25		A	
$I_{DDoutput}$	Positive Supply Current Per Output Pair		30		mA	2
V_{TT}	Load Termination Supply Voltage		$V_{DD} - 2.0$		V	3
R_{LOAD}	Output Termination Load Resistance		50		Ω	3
P_{Dcore}	Power Dissipation Switch Core		7.4		W	
$P_{Doutput}$	Dissipation per terminated output pair		32		mW	4
$P_{DinputAC}$	Dissipation per AC coupled input pair		2.8		mW	5
$P_{DinputDC}$	Dissipation per DC coupled input pair		9.8		mW	6
Θ_{JC}	Thermal Resistance Junction to Case		2.2		°C/W	

Notes: 1. T_C measured at case top. Use of adequate heatsink is required.

2. $I_{DDoutput}$ is additive to I_{DDcore} for each terminated differential output pair (true and complement).

3. The V_{TT} and R_{LOAD} combination is subject to maximum output current and power restrictions.

4. $P_{Doutput}$ is additive to P_{Dcore} for each terminated differential output pair (true and complement).

5. $P_{DinputAC}$ is additive to P_{Dcore} for each AC-coupled differential input pair (true and complement).

6. $P_{DinputDC}$ is additive to P_{Dcore} for each DC-coupled differential input pair (true and complement).

7. Functionality and/or adherence to electrical specifications is not implied when the device is subjected to conditions that exceed, singularly or in combination, the operating range specified.

Table 3. DC Characteristics—PECL I/O³

Parameter	Condition	Symbol	Minimum	Nominal	Maximum	Unit
Input common mode voltage range		V_{ICOM}	$V_{DD} - 1500$	—	$V_{DD} - 1100$	mV
Input differential voltage (pk-pk)	(1)	V_{IDIFF}	600	—	2400	mV
Output common mode voltage range		V_{OCOM}	$V_{DD} - 1500$	—	$V_{DD} - 1100$	mV
Output differential voltage (pk-pk)	(2)	V_{ODIFF}	1200	—	2400	mV
Input termination resistance		R_{IN}		50		Ohm

Table 4. DC Characteristics—TTL Inputs³

Parameter	Condition	Symbol	Minimum	Nominal	Maximum	Unit
Input HIGH voltage		V_{IH}	2.0	—	$V_{DD} + 1.8$	V
Input LOW voltage		V_{IL}	0	—	0.8	V
Input HIGH current	$V_{IH(MAX)}$	I_{IH}	—	—	200	uA
Input LOW current	$V_{IL(MIN)}$	I_{IL}	-400	-200	—	uA
Input capacitance		C_{IN}	—	—	TBD	pF

Notes (Tables 3 and 4):

1. Differential inputs.
2. $R_{LOAD} = 50$ ohms to $V_{TT} = V_{DD} - 2.0V$.
3. Specifications apply over recommended operating ranges.

TQ8034

PRELIMINARY DATA SHEET

Table 5. AC Characteristics

Parameter	Condition	Symbol	Minimum	Nominal	Maximum	Unit
Maximum Data Rate/port			1.6			Gb/s
Minimum Input pulse width	(1)	T_{pw}	625	—	—	ps
Rise/Fall time	20-80%	$T_{r/f}$	—	—	220	ps
Channel Propagation Delay						
IN(0:31)	(1)	T_{pd}	—	—	2.0	ns
IN(32:33)	(1)	T_{pd}	—	—	1.75	ns
Ch-to-Ch Prop. Delay Skew OUT(0:31)	(1)	T_{skew}			500	ps
OUT(0:33) Jitter	(2)	T_{jitter}	—	70	150	ps

Notes: 1. Measured at crossing point of true and complement

2. Crossing of (On) – (NO) measured with $2^{23} - 1$ PRBS, measured over extended time.

Table 6. Timing Specifications

Symbol	Parameter	Minimum	Maximum	Unit
t_{sar} [IADD],[OADD]	Address to Load Set-up Time	3		ns
t_{har} [IADD],[OADD]	Address to Load Hold Time	3		ns
t_{pwl}	Load Pulse Width	7		ns
t_{ldh}	Load to Configure Delay	0		ns
t_{ldl}	Configure to Load Delay			ns
t_{pwc}	Configure Pulse Width	7		ns
t_{dcf}	Configure to Data Valid		30	ns

Figure 1. Sequential Configuration (User Defined Input Address; MODE0 = 0, MODE1 = 0)

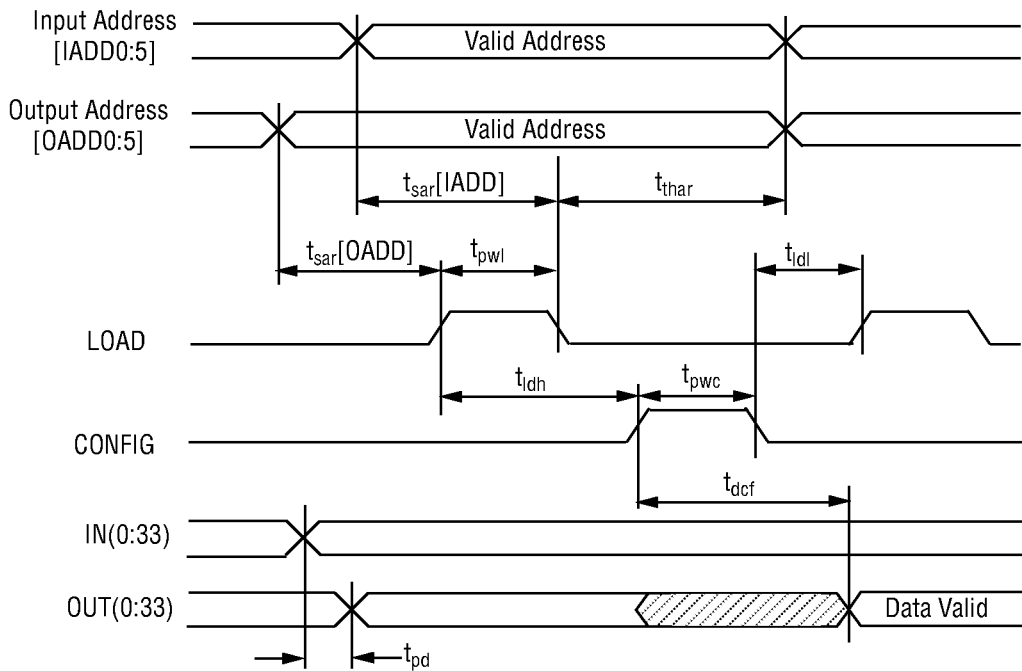

** Data remains valid on outputs with unchanged configuration

Figure 2. Sequential Configuration (Default Input Address; MODE0 = 0, MODE1 = 1)

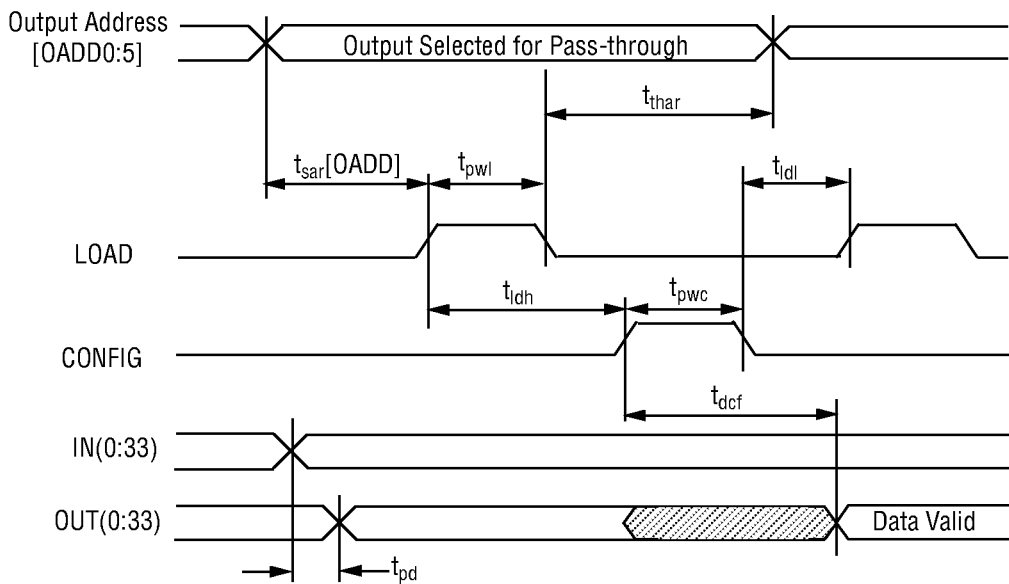

** Data remains valid on outputs with unchanged configuration

SWITCHING PRODUCTS

TQ8034

PRELIMINARY DATA SHEET

Figure 3. Multicast Configuration (User Defined Input Address; MODE0 = 1, MODE1 = 0)

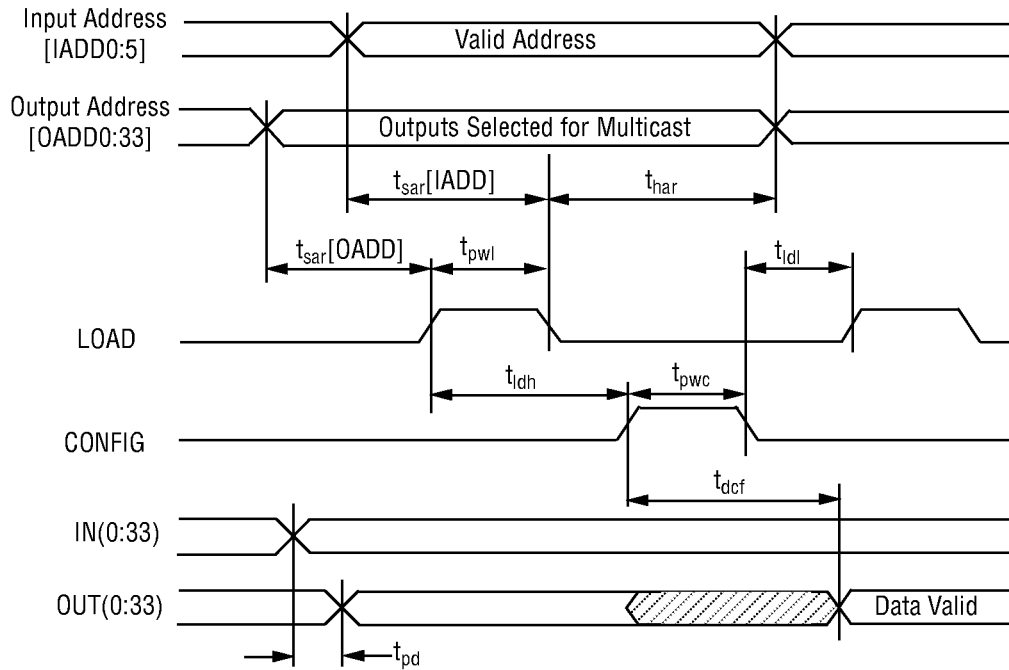

** Data remains valid on outputs with unchanged configuration

Figure 4. Multicast Configuration (Default Input Address; MODE0 = 1, MODE1 = 1)

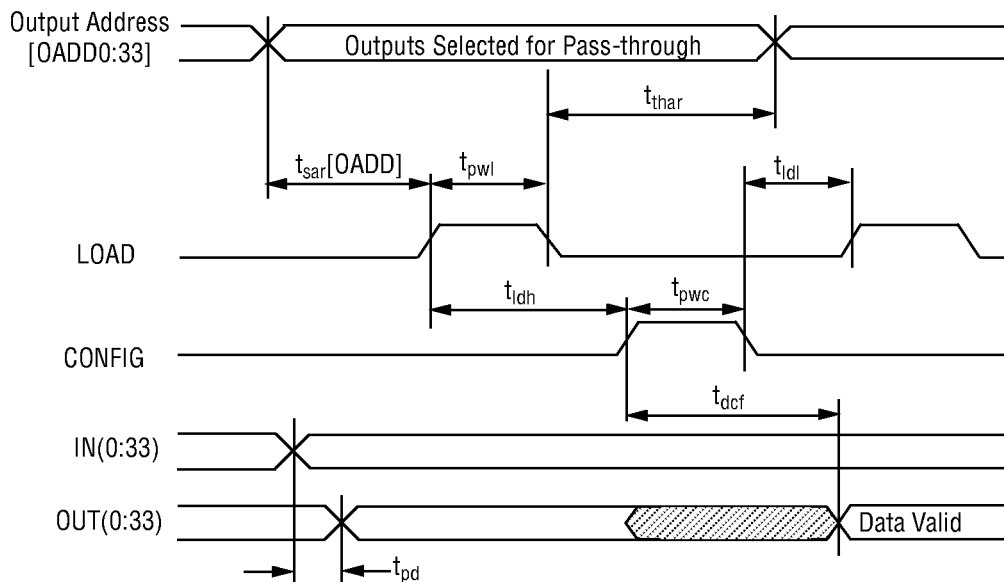

** Data remains valid on outputs with unchanged configuration

Figure 5. TQ8034 Pinout —Top View

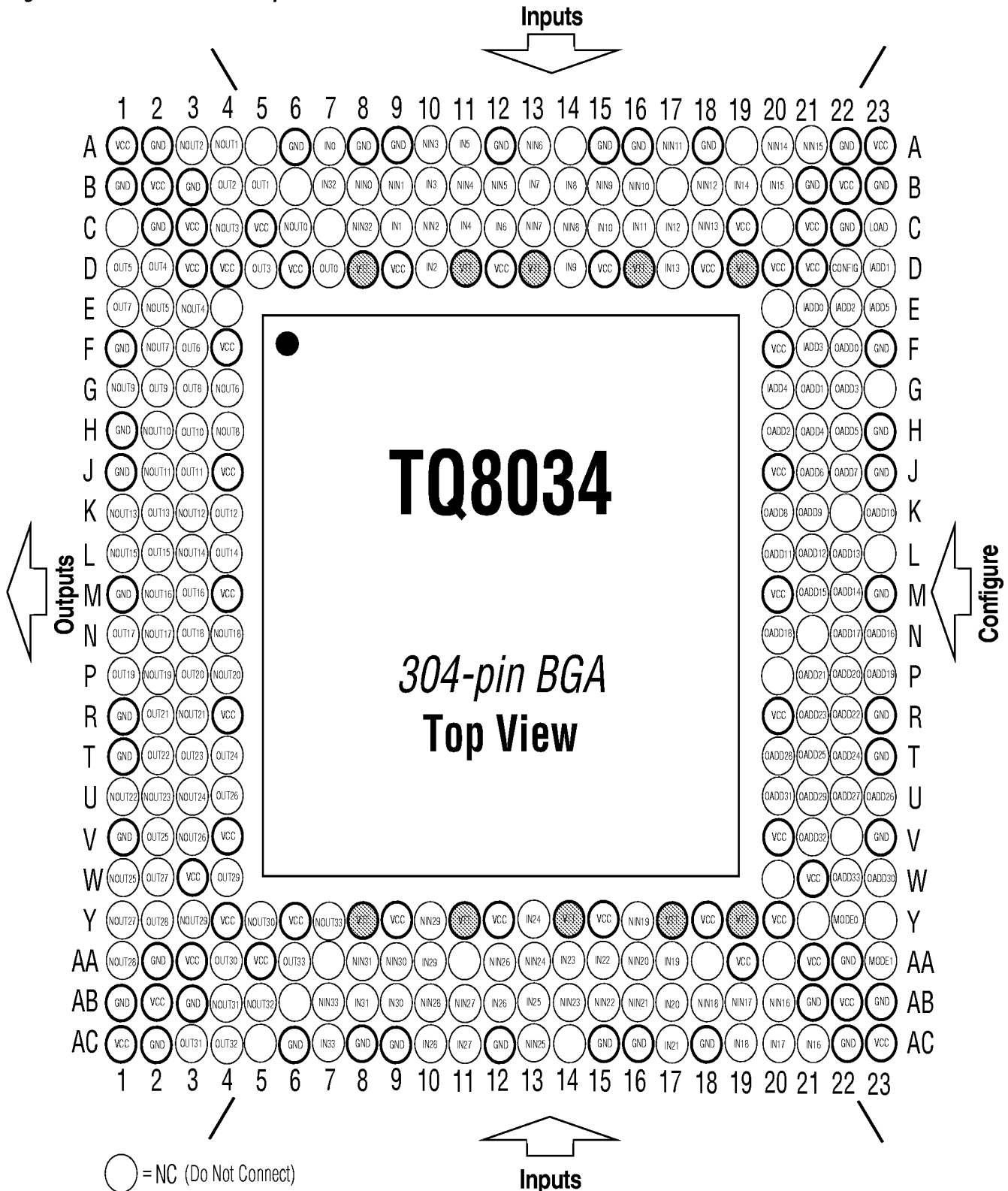

SWITCHING PRODUCTS

TQ8034

PRELIMINARY DATA SHEET

Table 7. Pin Descriptions

Signal	Type	Package Grid Ref	Description	
Control and Configuration				
CONFIGURE	TTL Input	D22	Active High. Enables transfer of data from program latches to configuration latches.	
LOAD	TTL Input	C23	Active High. Enables program latches to accept new input address data based upon which output(s) are selected using OADD inputs.	
MODE0	TTL Input	Y22	Program mode select LSB	
MODE1	TTL Input	AA23	Program mode select MSB	
Input Address Control				
IADD0	TTL Input	E21	Input address LSB	
IADD1	TTL Input	D23	Input address	
IADD2	TTL Input	E22	Input address	
IADD3	TTL Input	F21	Input address	
IADD4	TTL Input	G20	Input address	
IADD5	TTL Input	E23	Input address MSB	
Output Address Control				
			Sequential	Multicast
OADD0	TTL Input	F22	Output address LSB	Output select Bit 0
OADD1	TTL Input	G21	Output address	Output select Bit 1
OADD2	TTL Input	H20	Output address	Output select Bit 2
OADD3	TTL Input	G22	Output address	Output select Bit 3
OADD4	TTL Input	H21	Output address	Output select Bit 4
OADD5	TTL Input	H22	Output address MSB	Output select Bit 5
OADD6	TTL Input	J21	N/A	Output select Bit 6
OADD7	TTL Input	J22	N/A	Output select Bit 7
OADD8	TTL Input	K20	N/A	Output select Bit 8
OADD9	TTL Input	K21	N/A	Output select Bit 9
OADD10	TTL Input	K23	N/A	Output select Bit 10
OADD11	TTL Input	L20	N/A	Output select Bit 11
OADD12	TTL Input	L21	N/A	Output select Bit 12
OADD13	TTL Input	L22	N/A	Output select Bit 13
OADD14	TTL Input	M22	N/A	Output select Bit 14
OADD15	TTL Input	M21	N/A	Output select Bit 15
OADD16	TTL Input	N23	N/A	Output select Bit 16
OADD17	TTL Input	N22	N/A	Output select Bit 17
OADD18	TTL Input	N20	N/A	Output select Bit 18
OADD19	TTL Input	P23	N/A	Output select Bit 19
OADD20	TTL Input	P22	N/A	Output select Bit 20
OADD21	TTL Input	P21	N/A	Output select Bit 21
OADD22	TTL Input	R22	N/A	Output select Bit 22
OADD23	TTL Input	R21	N/A	Output select Bit 23
OADD24	TTL Input	T22	N/A	Output select Bit 24
OADD25	TTL Input	T21	N/A	Output select Bit 25
OADD26	TTL Input	U23	N/A	Output select Bit 26

Table 7. Pin Descriptions (cont.)

Signal	Type	Grid Ref	Description	
			Sequential	Multicast
OADD27	TTL Input	U22	N/A	Output select Bit 27
OADD28	TTL Input	T20	N/A	Output select Bit 28
OADD29	TTL Input	U21	N/A	Output select Bit 29
OADD30	TTL Input	W23	N/A	Output select Bit 30
OADD31	TTL Input	U20	N/A	Output select Bit 31
OADD32	TTL Input	V21	N/A	Output select Bit 32
OADD33	TTL Input	W22	N/A	Output select Bit 33
Output Ports				
OUT0,NOUT0	DPECL Outputs	D7,C6	True/Complement Data Out	OADD = 000000
OUT1,NOUT1	DPECL Outputs	B5,A4	True/Complement Data Out	OADD = 000001
OUT2,NOUT2	DPECL Outputs	B4,A3	True/Complement Data Out	OADD = 000010
OUT3,NOUT3	DPECL Outputs	D5,C4	True/Complement Data Out	OADD = 000011
OUT4,NOUT4	DPECL Outputs	D2,E3	True/Complement Data Out	OADD = 000100
OUT5,NOUT5	DPECL Outputs	D1,E2	True/Complement Data Out	OADD = 000101
OUT6,NOUT6	DPECL Outputs	F3,G4	True/Complement Data Out	OADD = 000110
OUT7,NOUT7	DPECL Outputs	E1,F2	True/Complement Data Out	OADD = 000111
OUT8,NOUT8	DPECL Outputs	G3,H4	True/Complement Data Out	OADD = 001000
OUT9,NOUT9	DPECL Outputs	G2,G1	True/Complement Data Out	OADD = 001001
OUT10,NOUT10	DPECL Outputs	H3,H2	True/Complement Data Out	OADD = 001010
OUT11,NOUT11	DPECL Outputs	J3,J2	True/Complement Data Out	OADD = 001011
OUT12,NOUT12	DPECL Outputs	K4,K3	True/Complement Data Out	OADD = 001100
OUT13,NOUT13	DPECL Outputs	K2,K1	True/Complement Data Out	OADD = 001101
OUT14,NOUT14	DPECL Outputs	L4,L3	True/Complement Data Out	OADD = 001110
OUT15,NOUT15	DPECL Outputs	L2,L1	True/Complement Data Out	OADD = 001111
OUT16,NOUT16	DPECL Outputs	M3,M2	True/Complement Data Out	OADD = 010000
OUT17,NOUT17	DPECL Outputs	N1,N2	True/Complement Data Out	OADD = 010001
OUT18,NOUT18	DPECL Outputs	N3,N4	True/Complement Data Out	OADD = 010010
OUT19,NOUT19	DPECL Outputs	P1,P2	True/Complement Data Out	OADD = 010011
OUT20,NOUT20	DPECL Outputs	P3,P4	True/Complement Data Out	OADD = 010100
OUT21,NOUT21	DPECL Outputs	R2,R3	True/Complement Data Out	OADD = 010101
OUT22,NOUT22	DPECL Outputs	T2,U1	True/Complement Data Out	OADD = 010110
OUT23,NOUT23	DPECL Outputs	T3,U2	True/Complement Data Out	OADD = 010111
OUT24,NOUT24	DPECL Outputs	T4,U3	True/Complement Data Out	OADD = 011000
OUT25,NOUT25	DPECL Outputs	V2,W1	True/Complement Data Out	OADD = 011001
OUT26,NOUT26	DPECL Outputs	U4,V3	True/Complement Data Out	OADD = 011010
OUT27,NOUT27	DPECL Outputs	W2,Y1	True/Complement Data Out	OADD = 011011
OUT28,NOUT28	DPECL Outputs	Y2,AA1	True/Complement Data Out	OADD = 011100
OUT29,NOUT29	DPECL Outputs	W4,Y3	True/Complement Data Out	OADD = 011101
OUT30,NOUT30	DPECL Outputs	AA4,Y5	True/Complement Data Out	OADD = 011110
OUT31,NOUT31	DPECL Outputs	AC3,AB4	True/Complement Data Out	OADD = 011111
OUT32,NOUT32	DPECL Outputs	AC4,AB5	True/Complement Data Out	OADD = 10xxxx
OUT33,NOUT33	DPECL Outputs	AA6,Y7	True/Complement Data Out	OADD = 11xxxx

Table 7. Pin Descriptions (cont.)

Input Ports	Type	Grid Ref.	Description	
IN0,NIN0	DPECL Input	A7,B8	True/Complement Data IN0	IADD=000000
IN1,NIN1	DPECL Input	C9,B9	True/Complement Data IN1	IADD=000001
IN2,NIN2	DPECL Input	D10,C10	True/Complement Data IN2	IADD=000010
IN3,NIN3	DPECL Input	B10,A10	True/Complement Data IN3	IADD=000011
IN4,NIN4	DPECL Input	C11,B11	True/Complement Data IN4	IADD=000100
IN5,NIN5	DPECL Input	A11,B12	True/Complement Data IN5	IADD=000101
IN6,NIN6	DPECL Input	C12,A13	True/Complement Data IN6	IADD=000110
IN7,NIN7	DPECL Input	B13,C13	True/Complement Data IN7	IADD=000111
IN8,NIN8	DPECL Input	B14,C14	True/Complement Data IN8	IADD=001000
IN9,NIN9	DPECL Input	D14,B15	True/Complement Data IN9	IADD=001001
IN10,NIN10	DPECL Input	C15,B16	True/Complement Data IN10	IADD=001010
IN11,NIN11	DPECL Input	C16,A17	True/Complement Data IN11	IADD=001011
IN12,NIN12	DPECL Input	C17,B18	True/Complement Data IN12	IADD=001100
IN13,NIN13	DPECL Input	D17,C18	True/Complement Data IN13	IADD=001101
IN14,NIN14	DPECL Input	B19,A20	True/Complement Data IN14	IADD=001110
IN15,NIN15	DPECL Input	B20,A21	True/Complement Data IN15	IADD=001111
IN16,NIN16	DPECL Input	AC21,AB20	True/Complement Data IN16	IADD=010000
IN17,NIN17	DPECL Input	AC20,AB19	True/Complement Data IN17	IADD=010001
IN18,NIN18	DPECL Input	AC19,AB18	True/Complement Data IN18	IADD=010010
IN19,NIN19	DPECL Input	AA17,Y16	True/Complement Data IN19	IADD=010011
IN20,NIN20	DPECL Input	AB17,AA16	True/Complement Data IN20	IADD=010100
IN21,NIN21	DPECL Input	AC17,AB16	True/Complement Data IN21	IADD=010101
IN22,NIN22	DPECL Input	AA15,AB15	True/Complement Data IN22	IADD=010110
IN23,NIN23	DPECL Input	AA14,AB14	True/Complement Data IN23	IADD=010111
IN24,NIN24	DPECL Input	Y13,AA13	True/Complement Data IN24	IADD=011000
IN25,NIN25	DPECL Input	AB13,AC13	True/Complement Data IN25	IADD=011001
IN26,NIN26	DPECL Input	AB12,AA12	True/Complement Data IN26	IADD=011010
IN27,NIN27	DPECL Input	AC11,AB11	True/Complement Data IN27	IADD=011011
IN28,NIN28	DPECL Input	AC10,AB10	True/Complement Data IN28	IADD=011100
IN29,NIN29	DPECL Input	AA10,Y10	True/Complement Data IN29	IADD=011101
IN30,NIN30	DPECL Input	AB9,AA9	True/Complement Data IN30	IADD=011110
IN31,NIN31	DPECL Input	AB8,AA8	True/Complement Data IN31	IADD=011111
IN32,NIN32	DPECL Input	B7,C8	True/Complement Data IN32	IADD=10xxxx
IN33,NIN33	DPECL Input	AC7,AB7	True/Complement Data IN33	IADD=11xxxx

Table 7. Pin Descriptions (cont.)

Power Pins and Unused Pins

Signal	Description	Grid Ref							
VTT	Input Termination	D8	D11	D13	D16	D19	Y19	Y17	
	Supply	Y14	Y11	Y8					
VDD	+3.3V Power Supply	A1	A23	B2	B22	C3	C19	C21	
		D3	D4	D6	D9	D12	D15	D18	
		D20	D21	F4	F20	J4	J20	M4	
		M20	R4	R20	V4	V20	W3	W21	
		Y4	Y6	Y9	Y12	Y15	Y18	Y20	
		AA3	AA5	AA19	AA21	AB2	AB22	AC1	
		AC23	C5						
GND	Ground Supply	A2	A6	A8	A9	A12	A15	A16	
		A18	A22	B1	B3	B21	B23	C2	
		C22	F1	F23	H1	H23	J1	J23	
		M1	M23	R1	R23	T1	T23	V1	
		V23	AA2	AA22	AB1	AB3	AB21	AB23	
		AC2	AC6	AC8	AC9	AC12	AC15	AC16	
		AC18	AC22						

SWITCHING PRODUCTS

Figure 7. Interface Circuits

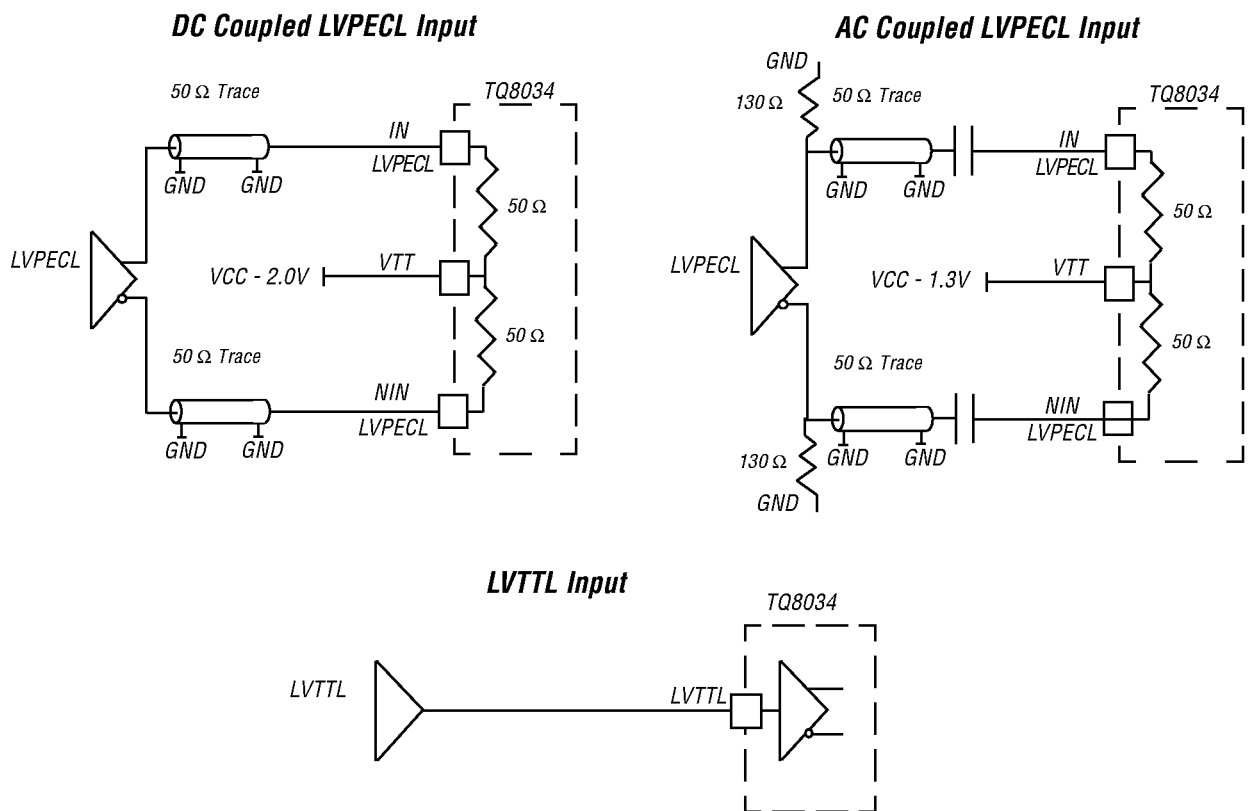

Figure 8. Typical Performance

Typical Performance at 1.6Gb/s
with 2²³-1 PRBS data

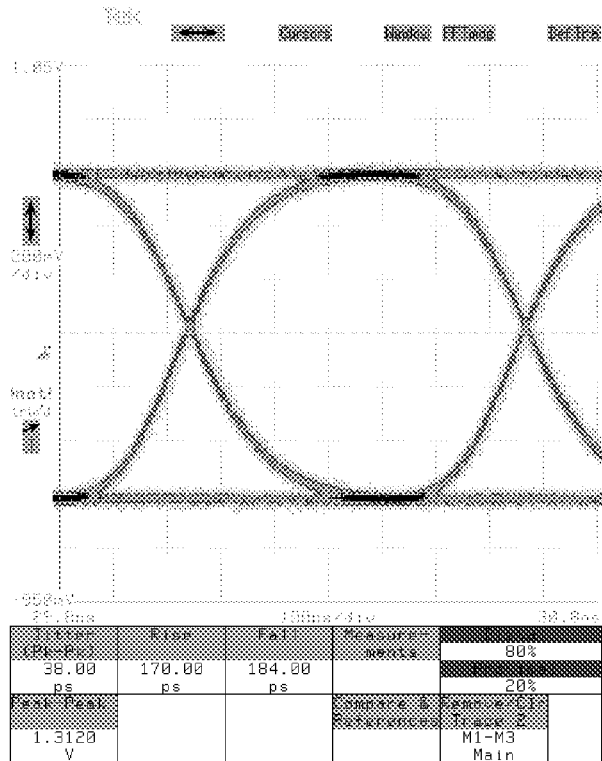
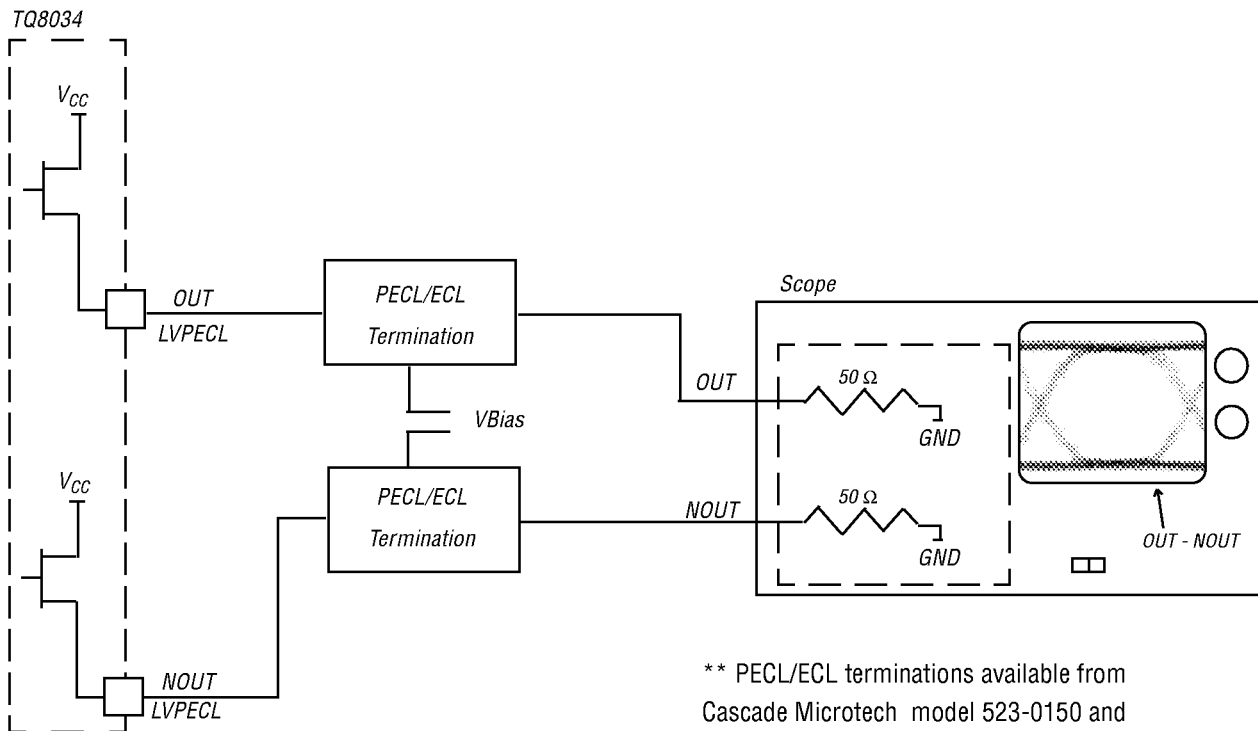
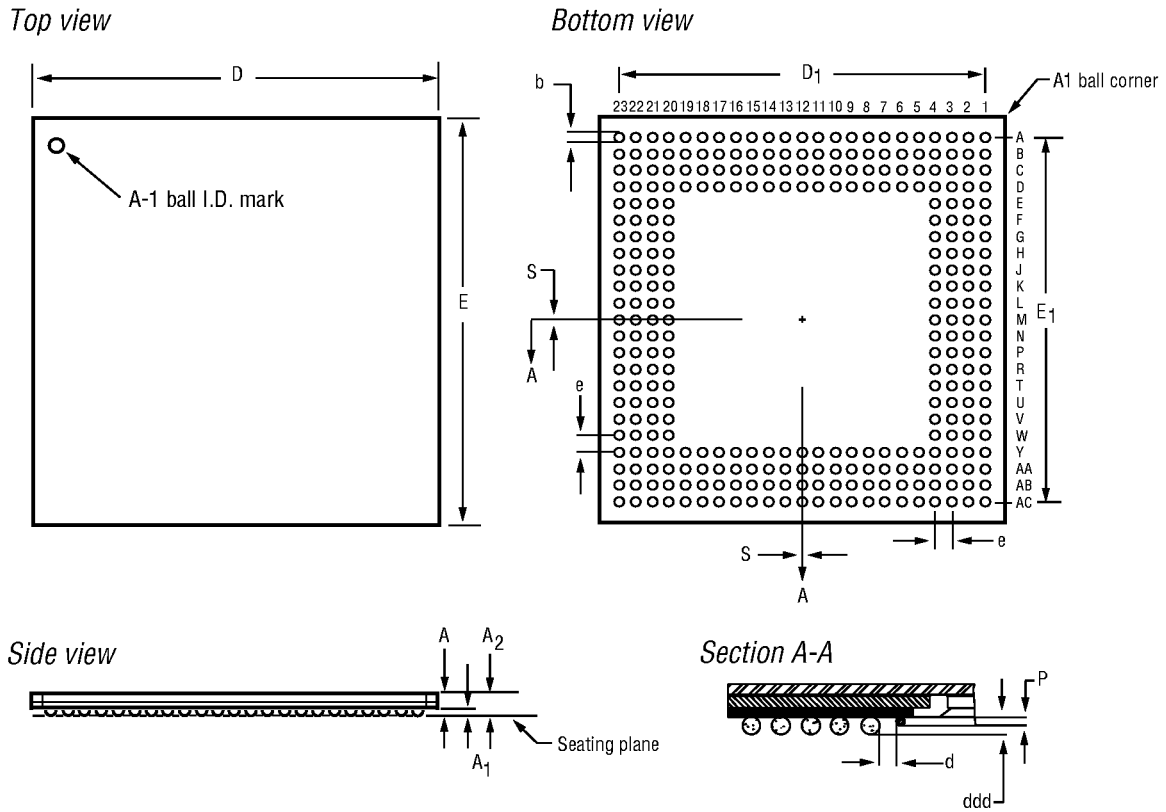

Figure 9. Suggested measurement setup



** PECL/ECL terminations available from Cascade Microtech model 523-0150 and Picosecond Pulse Labs model 5623

Figure 10. BGA Mechanical Dimensions



SWITCHING PRODUCTS

Table 8. BGA Dimensions (in millimeters)

Symbol	Parameter	Min.	Nom.	Max.
A	Overall thickness	1.41	1.54	1.67
A ₁	Ball Height	0.56	0.63	0.70
A ₂	Body thickness	0.85	0.91	0.97
D	Body size	30.90	31.00	31.10
D ₁	Ball footprint	27.84	27.94	28.04
E	Body size	30.90	31.00	31.10
E ₁	Ball footprint	27.84	27.94	28.04
b	Ball diameter	0.60	0.75	0.90
d	Distance encapsulation to balls		0.6	
e	Ball pitch		1.27	
ddd	Seating plane clearance	0.15	0.30	0.35
P	Encapsulation height	0.20	0.30	0.35
S	Solder ball placement	—	—	0.00
	PCB pad size		0.63	

TQ8034

PRELIMINARY DATA SHEET

Thermal Management

Most applications will require the use of a heatsink or other thermal management system in order to keep the package case temperature within the recommended operation limits. As long as the package case temperature does not exceed 85 degrees C, the die temperature will remain well within TriQuint's requirements for reliability.

Selection of a thermal management device is very dependent on the system mechanical and environmental constraints. Several vendors of heatsink and other thermal management systems support the TQ8034's thermally enhanced Ball Grid Array package. These vendors will work with you to evaluate the system requirements and recommend the best solution.

Heat Sink Vendors

Aavid Thermal Technologies
One Kool Path
P.O. Box 400
Laconia, NH 03247
603-528-3400

Sumitomo Metal (SMI)
2953 Bunker Hill Lane
Santa Clara, CA 95054
408-982-0990

Wakefield Engineering, Inc.
60 Audubon Road
Wakefield, MA 01880
617-345-5900

Ordering Information

TQ8034

1.6 Gbit/sec 34x34 Crosspoint Switch

Additional Information

For latest specifications, additional product information, worldwide sales and distribution locations, and information about TriQuint:

Web: www.triquint.com

Email: sales@tqs.com

Tel: (503) 615-9000

Fax: (503) 615-8900

For technical questions and additional information on specific applications:

Email: applications@tqs.com

The information provided herein is believed to be reliable; TriQuint assumes no liability for inaccuracies or omissions. TriQuint assumes no responsibility for the use of this information, and all such information shall be entirely at the user's own risk. Prices and specifications are subject to change without notice. No patent rights or licenses to any of the circuits described herein are implied or granted to any third party. TriQuint does not authorize or warrant any TriQuint product for use in life-support devices and/or systems.

Copyright © 1999 TriQuint Semiconductor, Inc. All rights reserved.

Revision 0.1.B August 1999