

SI-5201

March 2007

■General Description

SI-5201 is an intelligent high-side switch with N-channel power MOSFET available in Sanken's TO220S-7 package. Over current and thermal shutdown circuits are integrated with control logic circuit in proprietary BCD process, and the output current limiting point can be externally set at two points of 30 A and 60 A. The DG output shows proportional current to the load current, so it can be used for output current monitoring and open load detection.

■Package

TO220S-7



■Applications

- Replacing a mechanical relay, fuse and discretely constructed power switch circuit in automotive and industrial applications with diagnostic feedback.

■Key Specifications

Parameter	Symbol	Rating	Unit
Operating power supply voltage	V _{BB}	30 max	V
Output current (DC)	I _o	60 max	A
Output current (pulse)	I _o (pulse)	120 max	A
Output on-resistance	R _{DS(ON)}	7 typ	mΩ
Quiescent circuit current	I _q	5 typ	μA

■Features

- Hybrid structure of N-channel MOSFET and control logic circuit
- Proprietary BCD process for control chip
- Sanken's TO220S-7 surface mount package
- N-channel MOSFET : V_{DSS} 40V, R_{DS(on)} : 7mΩ(typ) @25°C
- Over current protection: two current limiting points can be selected, 30 or 60 A by CL input.
- Protections :
 - thermal shutdown
 - Over voltage
 - Over current: 30A at CL input is high, 60A at CL input low
 - Reverse battery
- DG output : proportional current to load current (up to either 30A or 60A by CL input) for monitoring current and Detecting open load
- Very low quiescent current : 5μA(typ) at low input

SI-5201

March 2007

■ Standard connection

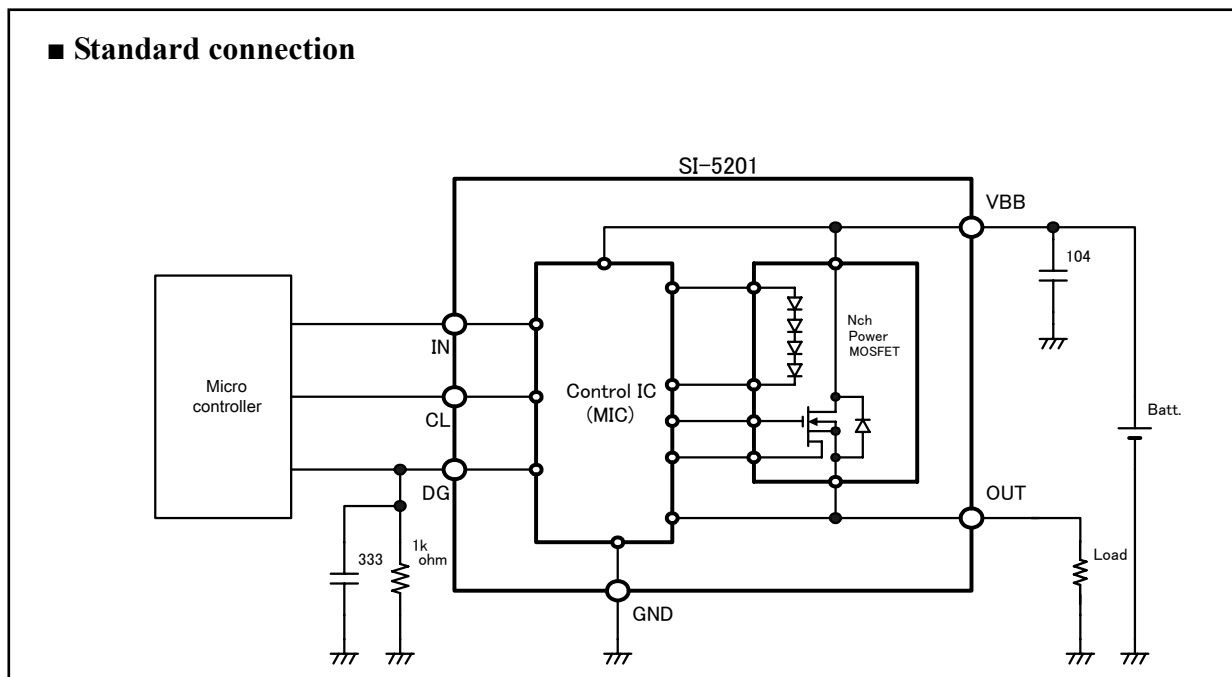

■ Absolute maximum ratings (Ta=25°C)

Parameter	Symbol	Ratings	Unit	
Supply Voltage	VBB	32	V	
Drain to Source Breakdown Voltage	VDS	40	V	
Output Current	Iout	60	A	
Logic Input Voltage	VIN	-0.3 to 7	V	
CL Pin Voltage to Select Current-Limitation Value	VCL	-0.3 to 7	V	
Junction Temperature	Tj	150	°C	
Storage Temperature	Tstg	-40 to +150	°C	
Thermal Resistance	Junction to Case	θj-c	1.1	°C /W

SI-5201

March 2007

■ Electrical characteristics (VBB=14V, Ta=25°C unless otherwise specified.)

Parameter	Symbol	Ratings			Unit	Remarks
		MIN	TYP	MAX		
Operating Voltage	VBB	6.0		30	V	
Quiescent Current	Iq		5.0	20	μA	VIN=0V, Vout=0V
IN Input Voltage	VthH	3.5			V	RL=2.8Ω
	VthL			1.5		
IN Input Current	IINH		50	75	μA	VIN=5V
CL Input Voltage	VthH-CL	3.5			V	RL=2.8Ω
	VthL-CL			1.5		
CL Input Current	ICLH		50	75	μA	VIN=5V, VCL=5V
ON State Resistance	RDS(ON)		7	8	mΩ	Ta=25°C, Io=12A
			11	13	mΩ	Ta=125°C, Io=12A
Output Leakage Current	Ileak		3.0	20	μA	VIN=0V, Vout=0V
Output Clamp Voltage	Vclamp	30	35	40	V	VIN=0V
Rise Time	tr	40		150	μs	Rout=2.8Ω
Fall Time	tf	40		120	μs	Rout=2.8Ω
Output Transition Time	ton		20	70	μs	Rout=2.8Ω
	toff		70	150	μs	Rout=2.8Ω
DG Pin Output Current	IDG	0	50	200	μA	Io=1A, VCL=0V (open)
		0.35	0.5	0.65	mA	Io=10A, VCL=0V (open)
		2.55	3.0	3.45	mA	Io=60A, VCL=0V (open)
		0	100	400	μA	Io=1A, VCL=5V
		0.7	1.0	1.3	mA	Io=10A, VCL=5V
		2.55	3.0	3.45	mA	Io=30A, VCL=5V
		4.0	5.0	5.5	mA	TSD or OCP is operating
DG Output Leakage Current	IDGleak			150	μA	Io=0A, VCL=0V,5V
DG Output Voltage	VDG			7	V	Io=10A, VCL=5V RDG=10kΩ
Over-current-Protection Starting current	Iocp	120			A	VCL=0V (open), t < tol
		60			A	VCL=0V (open), t > tol
		60			A	VCL=5V, t < tol
		30			A	VCL=5V, t > tol
OCP Level Changing Time	tol	65	100	135	ms	
OCP Reset Time	tocpr	2.6	4.0	5.4	ms	
OCP delay time	tocpr	0.26	0.4	0.8	ms	
Thermal Shutdown Starting temperature	TTSD	150			°C	
Over-voltage Protection Starting Voltage	VOVP	30	32.5	35	V	
Under-voltage Lockout Voltage	VUVLO	2	5	6	V	

SI-5201

March 2007

■DG Output Characteristics

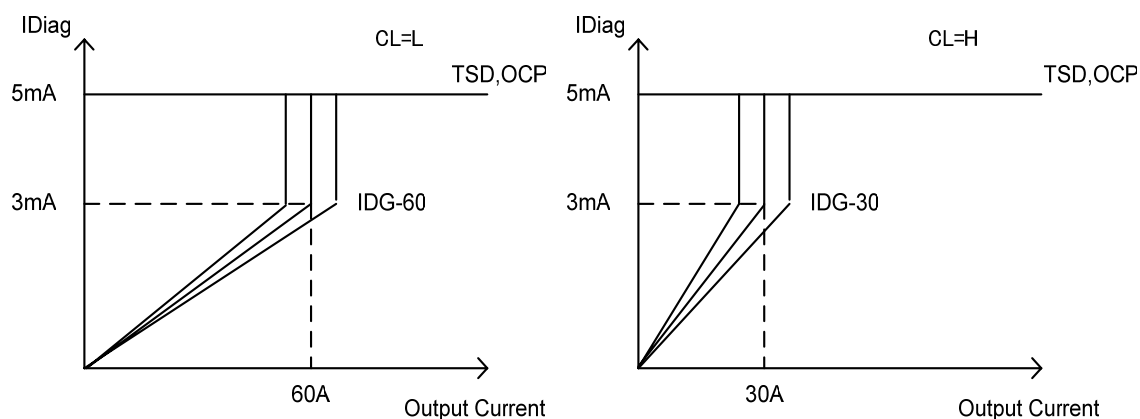

■Truth table

Operating Condition	Input	Output	DG Output Status	Remarks
Normal Operation	H	H	Linear	
	L	L	L	
Over-voltage	H	L	L	
	L	L	L	
Over-current Condition	H	L	H	
	L	L	L	
Thermal Overload	H	L	H	
	L	L	L	
Output Short to VB	H	VB	L	
	L	VB	L	
Output Short to GND	H	GND	H	
	L	GND	L	
Load Open	H	H	L	
	L	L	L	

●Linear=Linear Output Operation ●DG output status : H = High output level L = Low output level

SI-5201

March 2007

■ Pins function description

Symbol	Pin#	Function
OUT	1	Output (internally connected to the source of N-channel MOSFET)
OUT		
VBB	2	Supply voltage (internally connected to the Fin) / Drain of N-channel MOSFET
IN	3	Signal input
CL	4	Sets the current-limiting point at either 60A or 30A
DG	5	Monitors output current proportional to load current and diagnosis for load short to GND and TSD
GND	6	Ground

■ Package information

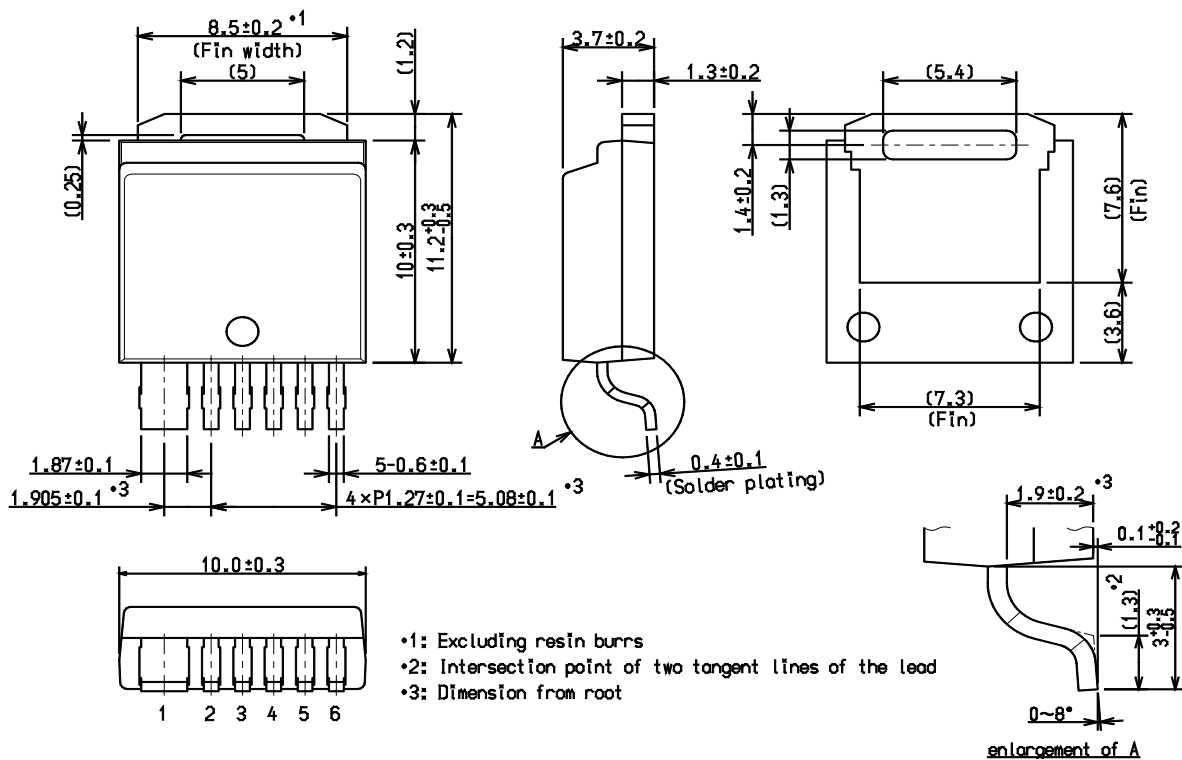

SI-5201

March 2007

■Operation timing

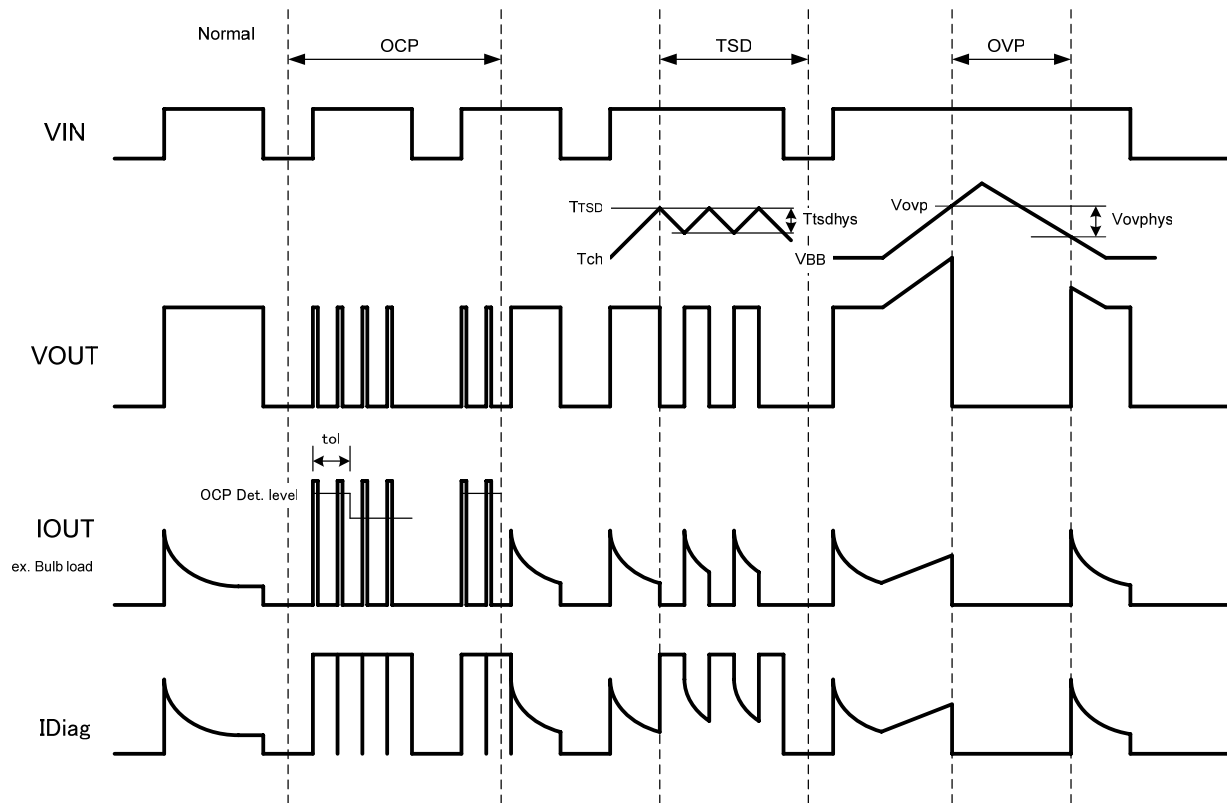

SI-5201

March 2007

<Worldwide Contacts>

Asia Pacific

China

Sanken Electric Hong Kong Co., Ltd.

Suite 1026 Ocean Centre, Canton Road, Tsimshatsui, Kowloon, Hong Kong

Tel: 852-2735-5262

Fax: 852-2735-5494

Sanken Electric (Shanghai) Co., Ltd.

Room3202, Maxdo Centre, Xingyi Road 8, Changning district, Shanghai, China

Tel: 86-21-5208-1177

Fax: 86-21-5208-1757

Taiwan Sanken Electric Co., Ltd.

Room 1801, 18th Floor, 88 Jung Shiau East Road, Sec. 2, Taipei 100, Taiwan R.O.C.

Tel: 886-2-2356-8161

Fax: 886-2-2356-8261

India

Saket Devices Pvt. Ltd.

Office No.13, First Floor, Bandal - Dhankude Plaza, Near PMT Depot, Paud Road, Kothrud, Pune - 411 038, India

Tel: 91-20-5621-2340

91-20-2528-5449

Fax: 91-20-2528-5459

Japan

Sanken Electric Co., Ltd. Overseas Sales Headquarters

Metropolitan Plaza Bldg. 1-11-1 Nishi-Ikebukuro, Toshima-ku, Tokyo 171-0021, Japan

Tel: 81-3-3986-6164

Fax: 81-3-3986-8637

Korea

Sanken Electric Korea Co., Ltd.

Mirae Asset Life Bldg. 6F, 168 Kongduk-dong, Mapo-ku, Seoul, 121-705, Korea

Tel: 82-2-714-3700

Fax: 82-2-3272-2145

Singapore

Sanken Electric Singapore Pte. Ltd.

150 Beach Road, #14-03 The Gateway West, Singapore 189720

Tel: 65-6291-4755

Fax: 65-6297-1744

SI-5201

March 2007

Europe

United Kingdom

Sanken Power Systems (UK) Limited

Pencoed Technology Park, Pencoed, Bridgend CF35 5HY. UK

Tel: 44-1656-869-100

Fax: 44-1656-869-162

North America

United States

Allegro MicroSystems, Inc.

115 Northeast Cutoff, Worcester, Massachusetts 01606, U.S.A.

Tel: 1-508-853-5000

Fax: 1-508-853-3353

Allegro MicroSystems, Inc. (Southern California)

14 Hughes Street, Suite B105, Irvine, CA 92618

Tel: 1-949-460-2003

Fax: 1-949-460-7837

CAUTION / WARNING

- The information in this publication has been carefully checked and is believed to be accurate; however, no responsibility is assumed for inaccuracies.
 - Sanken reserves the right to make changes without further notice to any products herein in the interest of improvements in the performance, reliability, or manufacturability of its products.
Before placing an order, Sanken advises its customers to obtain the latest version of the relevant information to verify that the information being relied upon is current.
 - Application and operation examples described in this catalog are quoted for the sole purpose of reference for the use of the products herein and Sanken can assume no responsibility for any infringement of industrial property rights, intellectual property rights or any other rights of Sanken or any third party which may result from its use.
 - When using the products herein, the applicability and suitability of such products for the intended purpose or object shall be reviewed at the users' responsibility.
 - Although Sanken undertakes to enhance the quality and reliability of its products, the occurrence of failure and defect of semiconductor products at a certain rate is inevitable. Users of Sanken products are requested to take, at their own risk, preventative measures including safety design of the equipment or systems against any possible injury, death, fires or damages to the society due to device failure or malfunction.
 - Sanken products listed in this catalog are designed and intended for the use as components in general purpose electronic equipment or apparatus (home appliances, office equipment, telecommunication equipment, measuring equipment, etc.). Before placing an order, the user's written consent to the specifications is requested.
When considering the use of Sanken products in the applications where higher reliability is required (transportation equipment and its control systems, traffic signal control systems or equipment, fire/crime alarm systems, various safety devices, etc.), please contact your nearest Sanken sales representative to discuss and obtain written confirmation of your specifications. The use of Sanken products without the written consent of Sanken in the applications where extremely high reliability is required (aerospace equipment, nuclear power control systems, life support systems, etc.) is strictly prohibited.
 - Anti radioactive ray design is not considered for the products listed herein.
 - This publication shall not be reproduced in whole or in part without prior written approval from Sanken.
-
- This is notification that you, as purchaser of the products/technology, are not allowed to perform any of the following:
 1. Resell or retransfer these products/technology to any party intending to disturb international peace and security.
 2. Use these products/technology yourself for activities disturbing international peace and security.
 3. Allow any other party to use these products/technology for activities disturbing international peace and security.Also, as purchaser of these products/technology, you agree to follow the procedures for the export or transfer of these products/technology, under the Foreign Exchange and Foreign Trade Law, when you export or transfer the products/technology abroad.