



MIL-SxK-ST11x (DC Coupled)
MIL-SxK-ST31x (AC Coupled)
MIL-SxK-ST41x (DC Coupled, Jam)
MIL-SxK-ST61x (AC Coupled, Jam)
MILITARY SFF OPTICAL TRANSCEIVER
 Gigabit Ethernet / 1x Fibre Channel Applications
 3.3V, 850nm VCSEL, Multimode, Up to 550M

FEATURES

- Industry standard MSA 2x5 footprint
- IPC Class III assembly and construction
- Industrial Temp range -40C to +85C operational
- All metal construction for rugged environments
- Optional Parylene C conformal coating
- Optional AC coupled I/O for TD and RD signals
- TX Disable and RX Signal Detect pins
- Optional RX data squelch on Signal Detect deassert
- Separate +3.3 V power pins per TX/RX port
- Industry standard duplex multimode LC receptacle
- Full compliance to IEEE and ANSI requirements
- EN-60825/ IEC-825 / CDRH Class 1 Compliant

BLOCK DIAGRAM

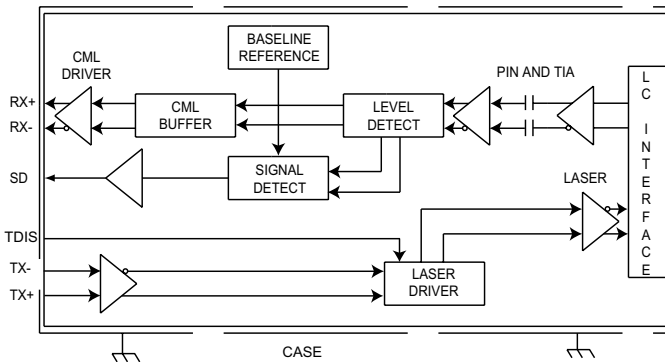

APPLICATIONS

The MIL-SxK-STxxx multimode optical fiber transceivers provide low profile, cost effective solutions for Gigabit Ethernet and 1x Fibre Channel multimode optical fiber data links with a duplex LC connector interface.

These transceivers are fully compliant with the IEEE Gigabit Ethernet and 1x Fibre Channel standards but can be used for any other data communications purpose within their operating parameters.

DESCRIPTION

The optic transceivers consist of transmitter and receiver functions combined in a Small Form Factor (SFF) module. The optical transmitter is a high output 850nm VCSEL. The transmitter input lines are driven with differential LVPECL signals applied to the Transmit (TX+ and TX-) pins. These signals are internally converted to a suitable modulation current by a CMOS integrated circuit. A Transmit Disable (TDIS) function is provided to enable control of the VCSEL optical output.

The optical receivers consist of PIN and Preamplifier assemblies and CMOS limiting post-amplifier integrated circuits. Outputs from the receivers consist of differential CML data signals on the Receive (RX+ and RX-) pins and a single ended LVTTTL signal detect function on the Signal Detect (SD) pin. For the -ST41 and -ST61 options, the RX data is squelched (JAM) upon Signal Detect deassert to prevent garbage data output when no optical signal is present.

ORDERING INFORMATION

MIL - S X K - S T X X X

Product Family	Shell Options	Application	Wavelength, Fiber, Coupling, Jam Options	Temperature and Coating
MIL-S= Military SFF (IPC Class III)	N= No GND Tabs (Flat Shell)	K= GigE / FC (1.0625 - 1.25Gbps)	ST11= 850 nm MM, DC coupled	H= -40 to 85 C, No Coating
			ST31= 850nm MM, AC coupled	
	T= GND Tabs		ST41= 850nm MM, DC coupled, JAM	M= -40 to 85 C, Conformal Coating
			ST61= 850nm MM, AC coupled, JAM	



MIL-SxK-STxxx MILITARY SFF OPTICAL TRANSCEIVER

Gigabit Ethernet / 1x Fibre Channel Applications
3.3V, 850nm VCSEL, Multimode, Up to 550M

ABSOLUTE MAXIMUM RATINGS

Absolute maximum limits mean that no catastrophic damage will occur if the product is subjected to these ratings for short periods, provided each limiting parameter is in isolation and all other parameters have values within the performance specification. It should not be assumed that limiting values of more than one parameter can be applied to the product at the same time.

Parameter	Symbol	Minimum	Typical	Maximum	Unit
Storage Temperature	T_S	-55		+100	°C
Lead Soldering Temperature	T_{SOLD}			+260	°C
Lead Soldering Time	t_{SOLD}			10	Seconds
Supply Voltage	V_{CC}	-0.5		+4.5	V
Data Input Voltage	V_I	-0.5		V_{CC}	V
Differential Input Voltage (p-p)	V_D			2.2	V
Output Current	I_O			50	mA

RECOMMENDED OPERATING CONDITIONS

Parameter	Symbol	Minimum	Typical	Maximum	Unit
Operating Temperature Limit	T_A	-40		+85	°C
Supply Voltage	V_{CC}	+3.135		+3.465	V
TX Common Mode Voltage	V_{CM}		2.0		V
TX Differential Input Voltage (p-p)	V_D	0.20		2.20	V
Transmit Disable Voltage	V_{TD}	2.0		V_{CC}	V
Transmit Enable Voltage	V_{TEN}	V_{EE}		0.8	V
RX Data Output Load	R_L		50		Ohms

DETAIL OF DATA I/O STAGES

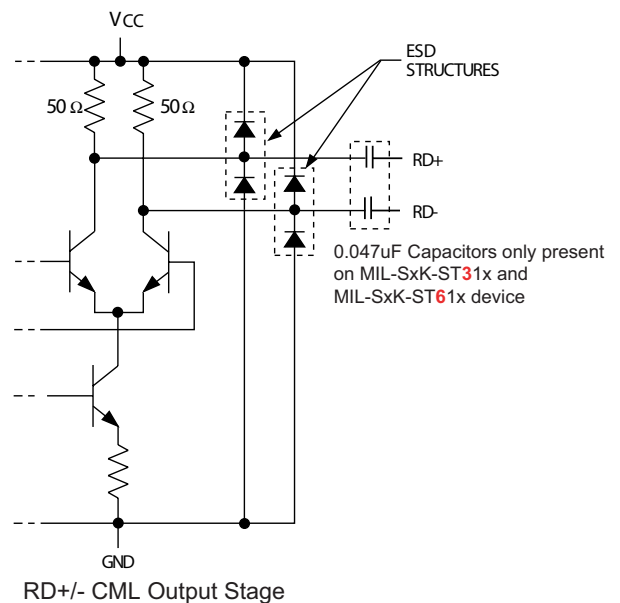
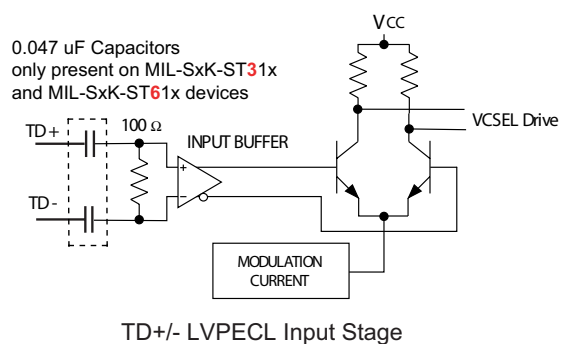

MIL-SxK-STxxx MILITARY SFF OPTICAL TRANSCEIVER

Gigabit Ethernet / 1x Fibre Channel Applications
3.3V, 850nm VCSEL, Multimode, Up to 550M

TRANSMITTERS

VCCTX = 3.135V to 3.465V, T_A = Operating Temperature Range

Parameter	Symbol	Minimum	Typical	Maximum	Unit
Optical Output Power ¹	P_o	-9.5		-4	dBm
Optical Output Wavelength	λ_{OUT}	830	850	860	nm
Spectral Width	$\Delta\lambda_{RMS}$			0.85	nm
Extinction Ratio	ER		10		dB
Supply Current	I_{CC}		55	75	mA
Optical Rise / Fall Time (20% - 80%)	$t_{R,F}$			0.26	nS
RIN				-117	dB/Hz
Coupled Power Ratio	CPR	9			dB
Total Jitter ¹			80	153	pS

1. BER=10⁻¹² @ 1.25Gbps, PRBS 2⁷-1, NRZ, Compliant with ANSI X3.297 / FC-PH-2

RECEIVERS

VCCR_X = 3.135V to 3.465V, T_A = Operating Temperature Range

Parameter	Symbol	Minimum	Typical	Maximum	Unit
Optical Sensitivity, FC (1.0625Gbps) ¹	P_I	-22	-23	0	dBm
Optical Sensitivity, GE (1.25Gbps) ¹		-21	-22	0	dBm
Optical Input Wavelength	λ_{IN}	770		860	nm
Optical Return Loss	ORL	12			dB
Supply Current	I_{CC}		70	120	mA
Signal Detect Assert Time	t_{SDAS}		<10	100	μ S
Signal Detect Deassert Time	t_{SDDA}		<10	350	μ S
Signal Detect Deassert Level ²	SD_{OFF}	-31			dBm
Signal Detect Assert Level	SD_{ON}			-21	dBm
Signal Detect Hysteresis	HYS	1.5	2.25	3.5	dB
RX Data Output - Low	$V_{OL} - V_{CC}$	-1.810		-1.475	V
RX Data Output - High	$V_{OH} - V_{CC}$	-1.165		-0.880	V

1. BER=10⁻¹² @ , PRBS 2⁷-1, NRZ, Compliant with ANSI X3.297 / FC-PH-2

2. RX Data outputs are squelched when Signal Detect is deasserted to prevent garbage data output when no optical signal is present.

LINK DISTANCES

Application	Fiber Specification	Distance
Gigabit Ethernet - IEEE 802.3z	62.5/125 - 160MHz*Km	220M
	62.5/125 - 200MHz*Km	275M
	50/125 - 400MHz*Km	500M
	50/125 - 500MHz*Km	550M
Fibre Channel - ANSI X3.297	62.5/125 - 160MHz*Km	300M
	50/125 - 500MHz*Km	500M



7444 West Wilson Avenue, Chicago, IL 60706 USA
Telephone: 708.867-9600, Fax: 708867-0996
Webpage: www.stratoslightwave.com

MIL-SxK-STxxx MILITARY SFF OPTICAL TRANSCEIVER

Gigabit Ethernet / 1x Fibre Channel Applications

3.3V, 850nm VCSEL, Multimode, Up to 550M

CONFORMAL COATING OPTION

Parameter	Value
Specification	MIL-I-46058C, Type XY
Coating:	Parylene type C
Deposition:	Vacuum deposited
Film Thickness:	1 MIL +/- 0.0002

REGULATORY COMPLIANCE

Requirement	Feature	Condition	Notes
MIL-STD-883-3015.7	ESD	Class II	2200V
IEC-801-2	ESD	Human Body Model	25KV
IEC-801-3	EMI	Immunity	10V/M
FCC	EMI	Class B	>20dB
EN 55022 (CISPR 22A)	EMI	Class B	10V/M
IEC-825 Issue 1993-11	Eye Safety	Class 1	TUV Certificate Number PENDING
FDA CDRH 21-CFR 1040	Eye Safety	Class 1	CDRH Accession Number PENDING



File Number: Pending

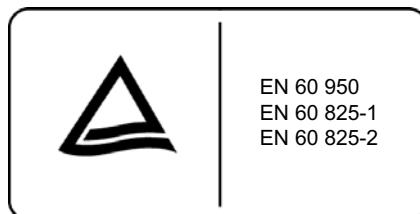

File Number: Pending



7444 West Wilson Avenue, Chicago, IL 60706 USA
Telephone: 708.867-9600, Fax: 708867-0996
Webpage: www.stratoslightwave.com

TDS-MIL-SxK-003
May 24, 2005

MIL-SxK-STxxx MILITARY SFF OPTICAL TRANSCEIVER

Gigabit Ethernet / 1x Fibre Channel Applications
 3.3V, 850nm VCSEL, Multimode, Up to 550M

MILITARY SMALL FORM FACTOR TRANSCEIVER PIN NUMBER ASSIGNMENTS TOP VIEW SHOWN

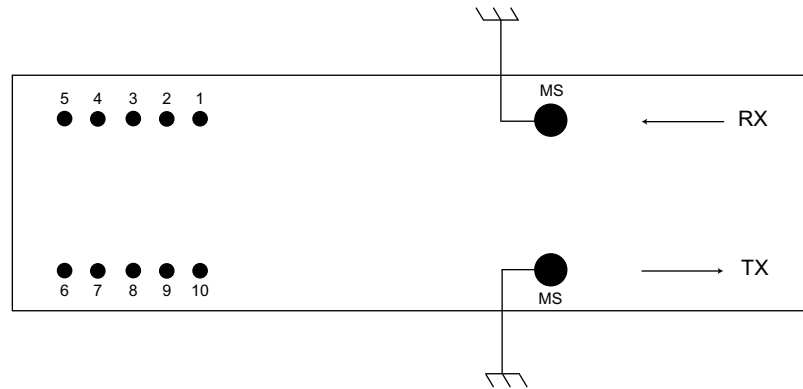

PIN FUNCTIONS

Pin Number	Symbol	Description	Logic Family
MS	MS	Mounting Studs Connect to chassis ground	N/A
1	VEERX	Receiver Signal Ground	N/A
2	VCCR _X	Receiver Power Supply	N/A
3	SD	Signal Detect (1= detect, 0= no signal)	LVTTL
4	RD ₋	Receive Data Out -	CML
5	RD ₊	Receive Data Out +	CML
6	VCCT _X	Transmit Power Supply	N/A
7	VEET _X	Transmit Signal Ground	N/A
8	TDIS	Transmit Disable (1= disable, 0= enable) internal 20Kohm pull-down (enable)	LVTTL
9	TD ₊	Transmit Data In +	CML
10	TD ₋	Transmit Data In -	CML



7444 West Wilson Avenue, Chicago, IL 60706 USA
 Telephone: 708.867-9600, Fax: 708867-0996
 Webpage: www.stratoslightwave.com

MIL-SxK-STxxx MILITARY SFF OPTICAL TRANSCEIVER

Gigabit Ethernet / 1x Fibre Channel Applications

3.3V, 850nm VCSEL, Multimode, Up to 550M

Application Schematic

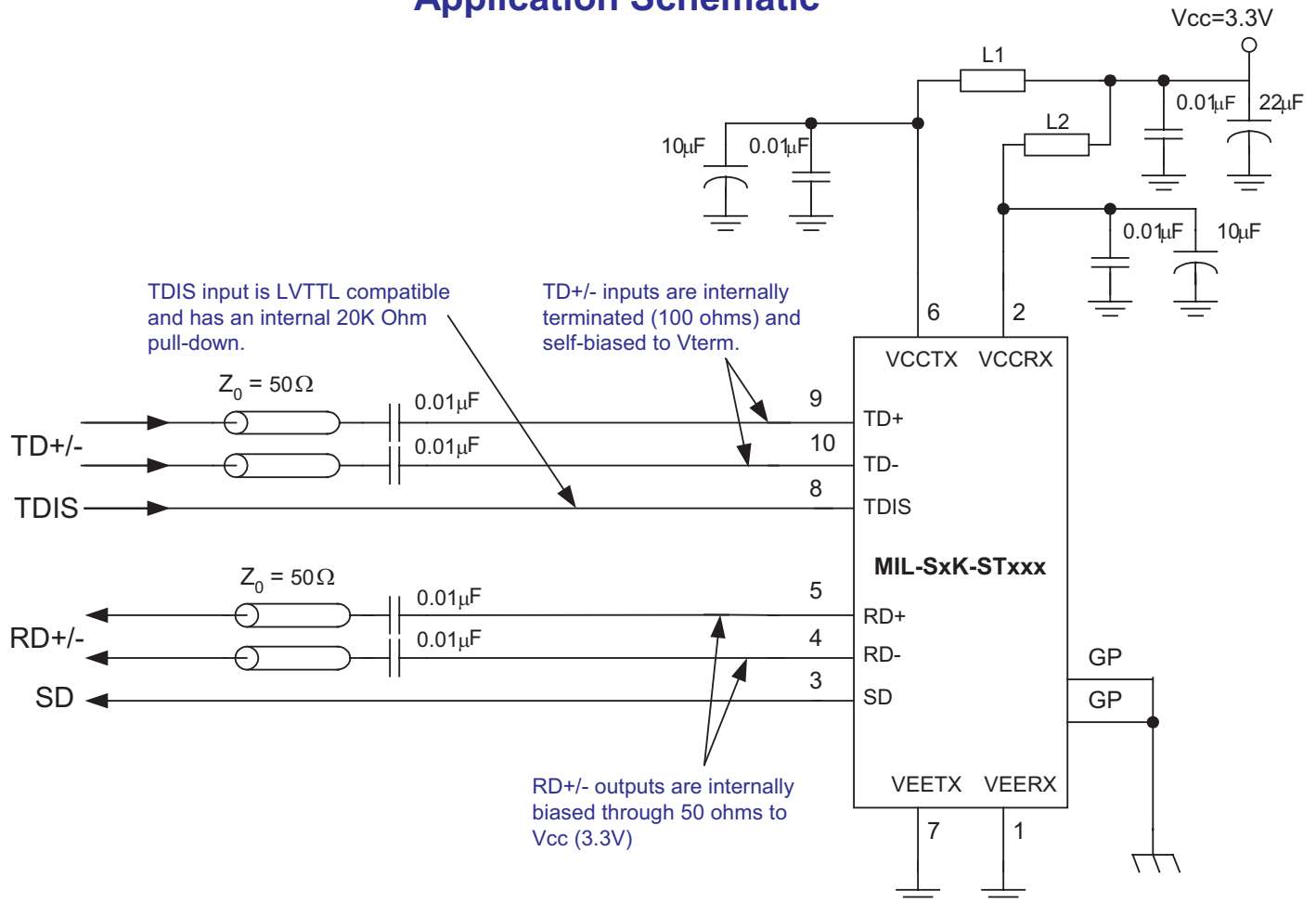

Notes:

- 1) L1 and L2 = MuRata BLM21A601S or equivalent (600Ω at 100MHz or better).
- 2) Route the differential pairs (TD +/- and RD +/-) together using 50Ω impedance matched traces.
- 3) Use separate power supply filtering for VCCTX and VCCR, as shown.
- 4) Use low ESR capacitors such as NPO or COG for AC Coupling of the TD+/- and RD+/- data signals. These capacitors are not required for the MIL-SxK-ST31x or MIL-SxK-ST61x device (this device includes internal 0.047µF capacitors on the TD and RD data lines).
- 5) Ground Posts (GP) are isolated from Signal Ground (Vee), and may be connected to Chassis Ground (as shown) or to Signal Ground if a Chassis Ground is not available.
- 6) A CML compliant DC I/O interface is possible for the RJL-ST11H-SO51A (no internal capacitors). Care could be taken with the external CML interface to reference the CML levels to the same Vcc as used for the transceiver.

MIL-SxK-STxxx MILITARY SFF OPTICAL TRANSCEIVER

Gigabit Ethernet / 1x Fibre Channel Applications

3.3V, 850nm VCSEL, Multimode, Up to 550M

MSA 2 x 5 OUTLINE DIMENSIONS For 0.600" Center to Center Mounting Dimensions Are Shown As: $\frac{\text{mm}}{\text{inches}}$

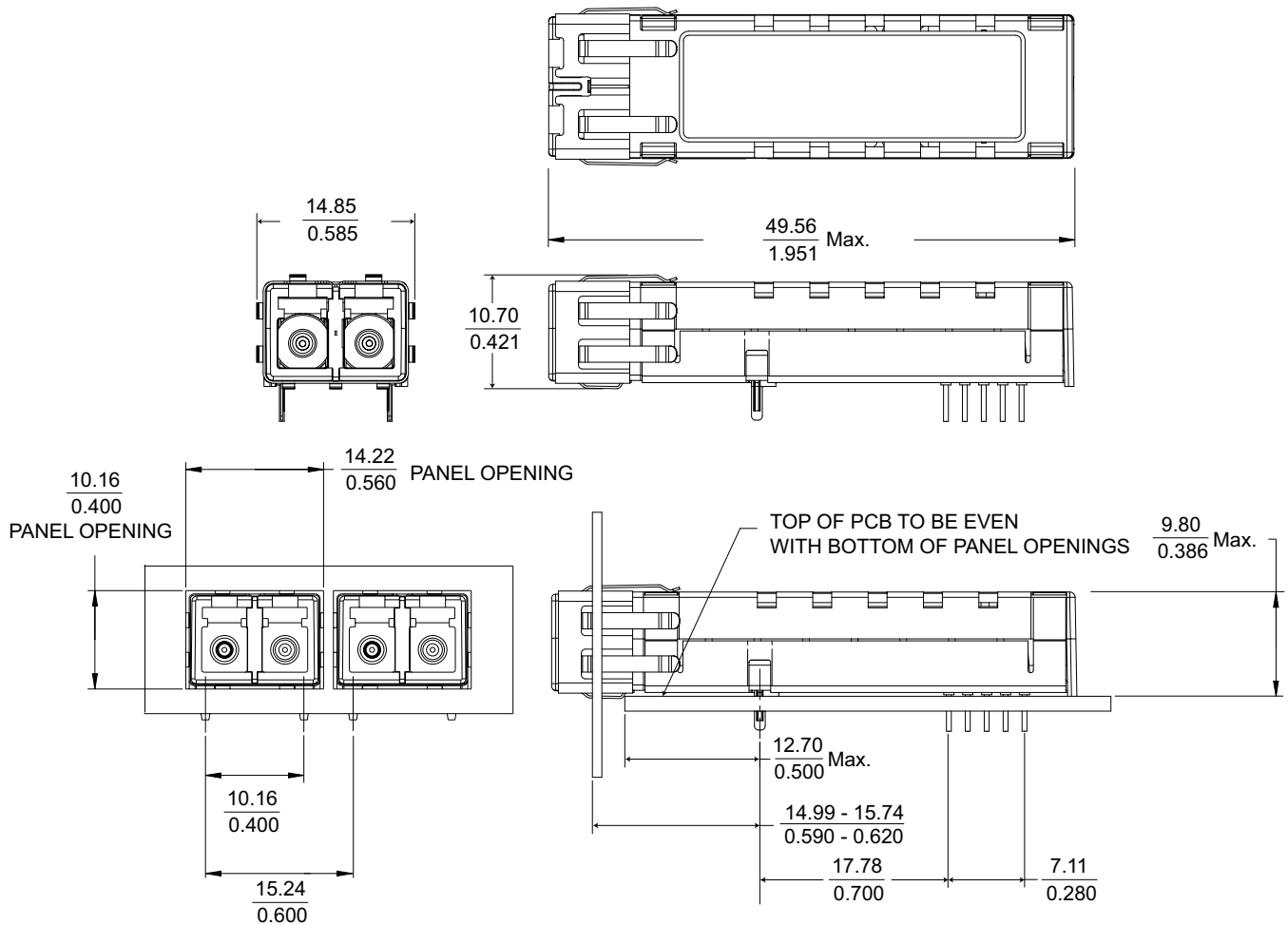

7444 West Wilson Avenue, Chicago, IL 60706 USA
Telephone: 708.867-9600, Fax: 708.867-0996
Webpage: www.stratoslightwave.com

MIL-SxK-STxxx MILITARY SFF OPTICAL TRANSCEIVER

Gigabit Ethernet / 1x Fibre Channel Applications

3.3V, 850nm VCSEL, Multimode, Up to 550M

PART NUMBER SUMMARY AND OPTIONS

Part Number	Flat Shell	Clip Shell	DC	AC	JAM	No JAM	Conf Coat
MIL-SNK-ST11H	X		X			X	
MIL-SNK-ST11M	X		X			X	X
MIL-SNK-ST31H	X			X		X	
MIL-SNK-ST31M	X			X		X	X
MIL-SNK-ST41H	X		X		X		
MIL-SNK-ST41M	X		X		X		X
MIL-SNK-ST61H	X			X	X		
MIL-SNK-ST61M	X			X	X		X
MIL-STK-ST11H		X	X			X	
MIL-STK-ST11M		X	X			X	X
MIL-STK-ST31H		X		X		X	
MIL-STK-ST31M		X		X		X	X
MIL-STK-ST41H		X	X		X		
MIL-STK-ST41M		X	X		X		X
MIL-STK-ST61H		X		X	X		
MIL-STK-ST61M		X		X	X		X

IMPORTANT NOTICE

Stratos Lightwave, Inc. reserves the right to make changes to or discontinue any optical link product or service identified in this publication, without notice. Stratos Lightwave recommends that its customers obtain the latest version of the publications to verify, before placing orders, that the information being relied on is current. Stratos Lightwave warrants performance of its optical link products to current specifications in accordance with the Stratos Lightwave standard warranty. Testing and other quality control techniques are utilized to the extent that Stratos Lightwave has determined it to be necessary to support this warranty. Specific testing of all parameters of each optical link product is not necessarily performed on all optical link products. Stratos Lightwave products are not designed for use in life support appliances, devices, or systems where malfunction of a Stratos Lightwave product can reasonably be expected to result in a personal injury. Stratos Lightwave customers using or selling optical link products for use in such applications do so at their own risk and agree to fully indemnify Stratos Lightwave for any damages resulting from such improper use or sale. Stratos Lightwave assumes no liability for Stratos Lightwave applications assistance, customer product design, software performance, or infringement of patents or services described herein. Nor does Stratos Lightwave warrant or represent that a license, either expressed or implied is granted under any patent right, copyright, or intellectual property right, and makes no representations or warranties that these products are free from patent, copyright, or intellectual property rights. Applications that are described herein for any of the optical link products are for illustrative purposes only. Stratos Lightwave makes no representation or warranty that such applications will be suitable for the specified use without further testing or modification.

STRATOS

7444 West Wilson Avenue, Chicago, IL 60706 USA
Telephone: 708.867-9600, Fax: 708.867-0996
Webpage: www.stratoslightwave.com

TDS-MIL-SxK-003
May 24, 2005