

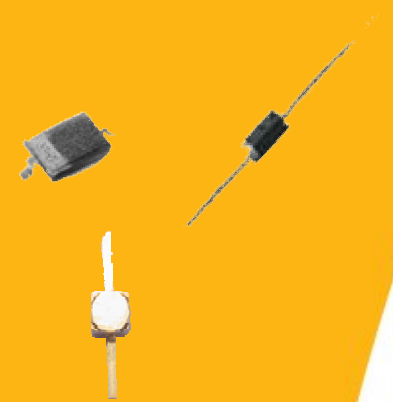

NW-DIODE SERIES



NoiseWave's noise diodes offer a symmetrical white Gaussian noise voltage distribution while maintaining a flat power spectral density versus frequency response. Applications for these diodes include built in test equipment, dithering for increased dynamic range of A/D converters, and as an economical source of broadband power.

Diodes are available in a variety of packages including an industry standard SOD-323 package, which allows it to be economically produced.

Specifications:

Operating Temperature: -55 to +125 deg C
Storage Temperature: -65 to +150 deg C

MODEL	FREQUENCY	V	I	RL	$\mu\text{V}/\sqrt{\text{Hz}}$	Package
NW101	0.1Hz -100 KHz	7 - 10	30 - 60 μA	2200	3.0	D0-35
NW102	0.1 Hz- 500 KHz	7 - 10	30 - 60 μA	2200	3.0	DO-35
NW103	0.1 Hz - 1 MHz	7 - 10	30 - 60 μA	2200	3.0	DO-35
NW104	0.1 Hz - 3 MHz	7 - 10	30 - 60 μA	2200	3.0	D0-35
NW201	0.1 Hz - 10 MHz	7 - 10	0.2 - 0.5 mA	2200	0.1	DO-35
MW202	0.1 Hz - 25 MHz	7 - 10	0.2 - 0.5 mA	2200	0.1	DO-35
NW203	0.1 Hz - 100 MHz	7 - 10	0.2 - 0.5 mA	50	.05	DO-35
ENR						
NW301	10 Hz - 3 GHz	8 - 12	5mA	50	30 - 35	SOD-323
NW302	10 Hz - 6 GHz	6 - 8	6mA	50	30 - 35	SOD-323, CH2
NW303	10 Hz - 8 GHz	8 - 12	8mA	50	30 - 35	BL, CH2
NW305	10 MHz - 11 GHz	8 - 12	10mA	50	29 - 34	BL, CH2
NW401	10 MHz - 18 GHz	8 - 12	10mA	50	28 - 33	P50, C, CH2
NW402	10 MHz - 40 GHz	8 - 12	15mA	50	25 - 30	P50, C

Phone: 973-386-1119
Fax: 973-386-1131
E-mail: info@noisewave.com
Website: <http://www.noisewave.com>

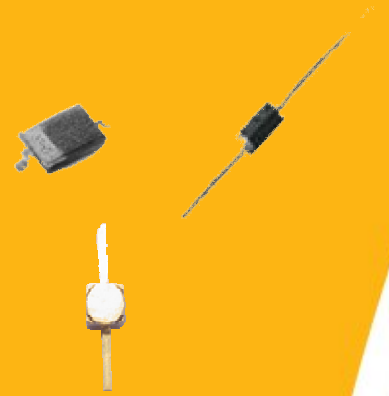

NW-CH2 Package
Diode Dimensions
(inches)

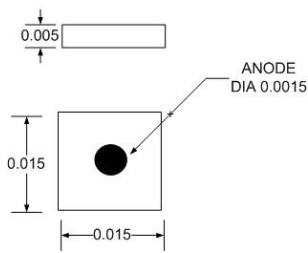

NW-C Package
Diode Dimensions
(inches)

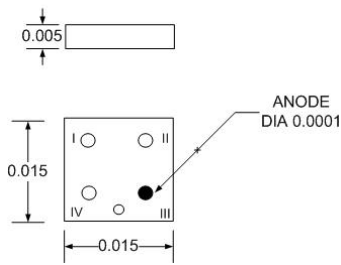

NW- BL Diode
Dimensions
(inches)

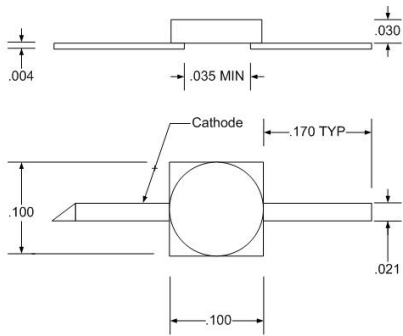

NW-SOD Package
Diode Dimensions
(inches)

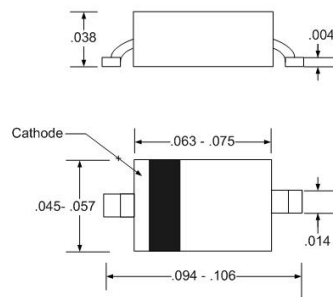

DO-35 Package
Diode Dimensions
(inches)

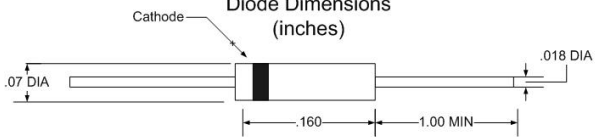

NW-P50 Package
Diode Dimensions
(inches)

