

SMA Connectors

Bulkhead Mount.	34
Field Replaceable	39
Flexible Cable	28
In-Series Adapters.	47
Panel Mount.	35
PC Mount.	20
Reverse Polarity.	93
Semi-Rigid Cable.	16
Specifications	14

Other Information

Assembly Instructions	98
Assembly Tools	94
Cable Assembly.	124
Cable Information	123
Capabilities	92
Mounting Hole Layouts	121
Numerical Index.	198
Ordering Information	2
Part Number Cross Reference	182
Tool Design and Fabrication	125

SMA Connectors

Specifications

ELECTRICAL RATINGS

Impedance: 50 ohms

Frequency Range:

Flexible cable connectors	0-12.4 GHz
Uncabled receptacles and brass adapters	0-18.0 GHz
Semi-rigid cable connectors, field replaceable connectors and stainless steel adapters	0-26.5 GHz

VSWR: (f = GHz)

	Straight Cabled Connectors	Right Angle Cabled Connectors
RG-178 cable	1.20 + .025f	1.20 + .03f
RG-316 cable	1.15 + .02f	1.15 + .03f
RG-58 cable	1.15 + .01f	1.15 + .02f
RG-142 cable	1.15 + .01f	1.15 + .02f
.086 semi-rigid	1.07 + .008f	
.141 semi-rigid (w/contact)	1.05 + .008f	
.141 semi-rigid (w/o contact)	1.035 + .005f	
Jack-bulkhead jack adapter and plug-plug adapter	1.05 + .01f	
Jack-jack adapter and plug-jack adapter	1.05 + .005f	
Uncabled receptacles	N/A	
Field replaceable (see page 39)	N/A	

Working Voltage: (Vrms maximum)†

Connectors for Cable Type	Sea Level	70K Feet
RG-178	170	45
RG-316	250	65
RG-58, RG-142, .086 semi-rigid, uncabled receptacles, .141 semi-rigid w/o contact	335	85
.141 semi-rigid with contact and adapters	500	125

Dielectric Withstanding Voltage: (VRMS minimum at sea level)†

Connectors for RG-178	500
Connectors for RG-316	750
Connectors for RG-58, RG-142, .086 semi-rigid, field replaceable, uncabled receptacles	1000
Connectors for .141 semi-rigid with contact and adapters	1500
Connectors for .141 semi-rigid w/o contact	N/A

Corona Level: (Volts minimum at 70,000 feet)†

Connectors for RG-178	125
Connectors for RG-316	190
Connectors for RG-58, RG-142, .086 semi-rigid uncabled receptacles, .141 semi-rigid w/o contact	250
Connectors for .141 semi-rigid with contact and adapters	375

Insertion Loss: (dB maximum)

Straight flexible cable connectors and adapters	0.06	\sqrt{f} (GHz), tested at 6 GHz
Right angle flexible cable connectors	0.15	\sqrt{f} (GHz), tested at 6 GHz
Straight semi-rigid cable connectors with contact	0.03	\sqrt{f} (GHz), tested at 10 GHz
Right angle semi-rigid cable connectors	0.05	\sqrt{f} (GHz), tested at 10 GHz
Straight semi-rigid cable connectors w/o contact	0.03	\sqrt{f} (GHz), tested at 16 GHz
Uncabled receptacles	N/A	

Insulation Resistance: 5000 megohms minimum

Contact Resistance: (milliohms maximum)

	Initial	After Environmental
Center contact (straight cabled connectors and uncabled receptacles)	3.0*	4.0*
Center contact (right angle cabled connectors and adapters)	4.0	6.0
Field replaceable connectors	6.0	8.0
Outer contact (all connectors)	2.0	N/A
Braid to body (gold plated connectors)	0.5	N/A
Braid to body (passivated or nickel plated connectors)	5.0	N/A

*N/A where the cable center conductor is used as a contact

RF Leakage: (dB minimum, tested at 2.5 GHz)

Flexible cable connectors, adapters and .141 semi-rigid connectors w/o contact	-60 dB
Field replaceable w/o EMI gasket	-70 dB
.086 semi-rigid connectors and .141 semi-rigid connectors with contact, and field replaceable with EMI gasket	-90 dB
Uncabled receptacles and adapters	N/A

RF High Potential Withstanding Voltage: (Vrms minimum, tested at 4 and 7 MHz)†

Connectors for RG-178	335
Connectors for RG-316	500
Connectors for RG-58, RG-142, .086 semi-rigid, .141 semi-rigid cable w/o contact, uncabled receptacles	670
Connectors for .141 semi-rigid with contact and adapters	1000

MECHANICAL RATINGS

Engagement Design: MIL-C-39012, Series SMA

Engagement/Disengagement Force: 2 inch-pounds maximum

Mating Torque: 7 to 10 inch-pounds

Coupling Proof Torque: 15 inch-pounds minimum

Coupling Nut Retention: 60 pounds minimum

Contact Retention: 6 lbs. minimum axial force (captivated contacts)
4 inch-ounce minimum torque (uncabled receptacles)

Cable Retention:

	Axial Force* (pounds)	Torque (in-oz)
Connectors for RG-178	10	N/A
Connectors for RG-316	20	N/A
Connectors for RG-58	40	N/A
Connectors for RG-142	45	N/A
Connectors for .086 semi-rigid	30	16
Connectors for .141 semi-rigid	60	55

*Or cable breaking strength whichever is less.

Durability: 500 cycles minimum

100 cycles minimum for .141 semi-rigid connectors w/o contact

ENVIRONMENTAL RATINGS (Meets or exceed the applicable paragraph of MIL-C-39012)

Temperature Range: - 65°C to + 165°C

Thermal Shock: MIL-STD-202, Method 107, Condition B

Corrosion: MIL-STD-202, Method 101, Condition B

Shock: MIL-STD-202, Method 213, Condition I

Vibration: MIL-STD-202, Method 204, Condition D

Moisture Resistance: MIL-STD-202, Method 106

†Avoid user injury due to misapplication. See safety advisory definitions on page 2

MATERIAL SPECIFICATIONS

141 SERIES CONNECTORS

Bodies: Stainless steel per QQ-S-763, gold plated* per MIL-G-45204 .00005" min. for soldered bodies and .00001" min. for unsoldered bodies or passivated per MIL-F-14072

Contacts: Male - brass per QQ-B-626, gold plated per MIL-G-45204 .00005" min.
Female - beryllium copper per QQ-C-530, gold plated per MIL-G-45204 .00005" min.

Nut Retention Spring: Beryllium copper per QQ-C-533. Unplated

Insulators: PTFE fluorocarbon per ASTM D 1710 and ASTM D 1457 or Tefzel per ASTM D 3159

Expansion Caps: Brass per QQ-B-613, gold plated per MIL-G-45204 .00001" min. or nickel plated per QQ-N-290

Crimp Sleeves: Copper per WW-T-799 or brass per QQ-B-613, gold plated per MIL-G-45204 .00001" min. or nickel plated per QQ-N-290

Mounting Hardware: Stainless steel per QQ-S-763, gold plated per MIL-G-45204 .00001" min. or passivated per MIL-F-14072

Gasket and Seal Rings: Silicone rubber per ZZ-R-765

142 SERIES CONNECTORS

Bodies: Brass per QQ-B-626, gold plated* per MIL-G-45204 .00001" min. or nickel plated per QQ-N-290

Contacts: Male - brass per QQ-B-626, gold plated per MIL-G-45204 .00003" min.
Female - beryllium copper per QQ-C-530, gold plated per MIL-G-45204 .00003" min.

Nut Retention Spring: Beryllium copper per QQ-C-533. Unplated

Insulators: PTFE fluorocarbon per ASTM D 1710 and ASTM D 1457 or Tefzel per ASTM D 3159

Expansion Caps: Brass per QQ-B-613, gold plated per MIL-G-45204 .00001" min. or nickel plated per QQ-N-290

Crimp Sleeves: Copper per WW-T-799 or brass per QQ-B-613, gold plated per MIL-G-45204 .00001" min. or nickel plated per QQ-N-290

Mounting Hardware: Brass per QQ-B-626 or QQ-B-613, gold plated per MIL-G-45204 .00001" min. or nickel plated per QQ-N-290

Gaskets: Interface gaskets not supplied with brass connectors

Seal Rings: Silicone rubber per ZZ-R-765

EMI Gaskets: Conductive silicone rubber per MIL-G-83528, Type M

* All gold plated parts include a .00005" min. nickel underplate barrier layer.

MATING ENGAGEMENT FOR SMA SERIES PER MIL-C-39012

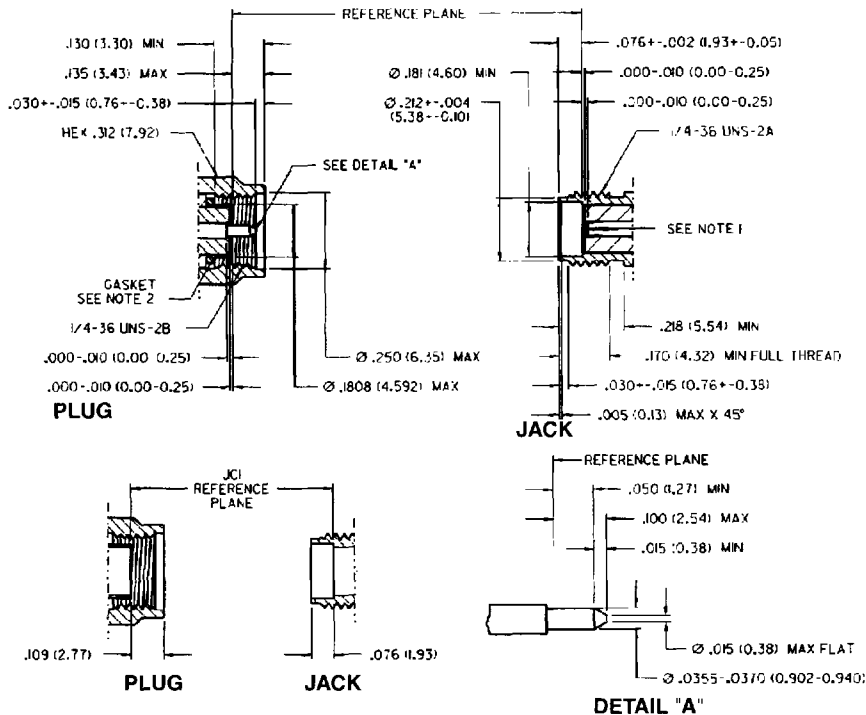

SMA Connectors

For Semi-Rigid Cable

JOHNSON
Components

Inches (millimeters)
customer drawings available upon request

Straight Solder Type Plug - with contact, captive nut

Thin wall connector interface for .141 cable

Thick wall connector interface for .086 cable

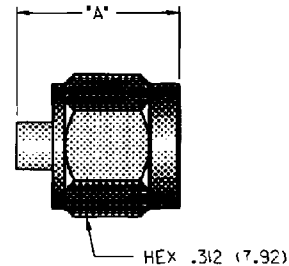

CABLE TYPE	VSWR & FREQ. RANGE	PRODUCT SERIES	GOLD PLATED	NICKEL PLATED	PASSIVATED (nut only)
.086 Semi-Rigid "A" = .405 (10.29)	0-18 GHz: 1.07 + .008 f (GHz) 26.5 GHz: 1.35 Max	Brass	142-0693-001	142-0693-006	
		Stainless Steel	141-0693-001		141-0693-002
.141 Semi-Rigid "A" = .440 (11.18)	0-26.5 GHz: 1.05+.008 f (GHz)	Brass	142-0694-001*	142-0694-006*	
		Stainless Steel	141-0694-001		141-0694-002

Assembly instructions page 103.

*Coupling proof torque 8 inch-pounds maximum.

Straight Solder Type Plug - without contact, thread-on nut

Thin wall connector interface

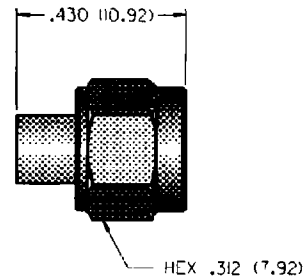
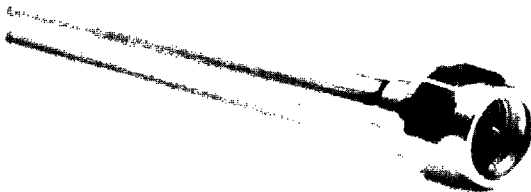

CABLE TYPE	VSWR & FREQ. RANGE	PRODUCT SERIES	GOLD PLATED	NICKEL PLATED	PASSIVATED (nut only)
.141 Semi-Rigid	1.035 + .005 f (GHz) 0-26.5 GHz	Brass	142-0694-011	142-0694-016	
		Stainless Steel	141-0694-011		141-0694-012

Assembly instructions page 104.

Center conductor of cable serves as contact.

Straight Solder Type Plug - with contact, thread-on nut

Thick wall connector interface

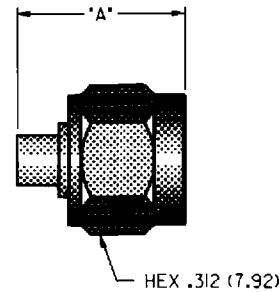
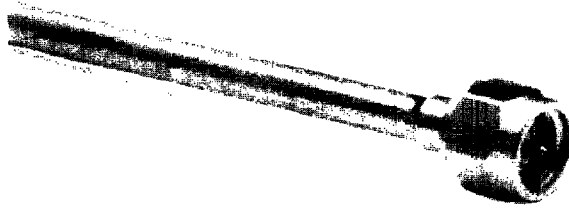

CABLE TYPE	VSWR & FREQ. RANGE	PRODUCT SERIES	GOLD PLATED	NICKEL PLATED	PASSIVATED (nut only)
.086 Semi-Rigid "A" = .405 (10.29)	0-18 GHz: 1.07 + .008 f (GHz) 26.5 GHz: 1.35 Max	Brass	142-0693-051	142-0693-056	
		Stainless Steel	141-0693-051		141-0693-052
.141 Semi-Rigid "A" = .438 (11.13)	0-26.5 GHz: 1.05+.008 f (GHz)	Brass	142-0694-051	142-0694-056	
		Stainless Steel	141-0694-051		141-0694-052

Assembly instructions page 107.

Straight Solder Type Plug - Short Profile without contact, captive nut

Thin wall connector interface

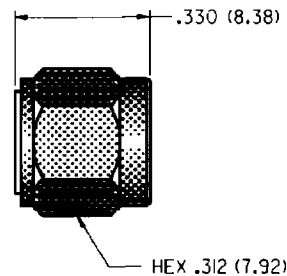

CABLE TYPE	VSWR & FREQ. RANGE	PRODUCT SERIES	GOLD PLATED	NICKEL PLATED	PASSIVATED (nut only)
.141 Semi-Rigid	1.035 + .005 f (GHz) 0-26.5 GHz	Brass	142-0694-031	142-0694-036	
		Stainless Steel	141-0694-031		141-0694-032

Assembly instructions page 106.

Center conductor of cable serves as contact.

See page 97 for coupling nut assembly tool.

SMA Connectors

For Semi-Rigid Cable

JOHNSON
Components

Inches (millimeters)
customer drawings available upon request

Straight Solder Type Plug without contact, slide-on nut

Thick wall connector interface

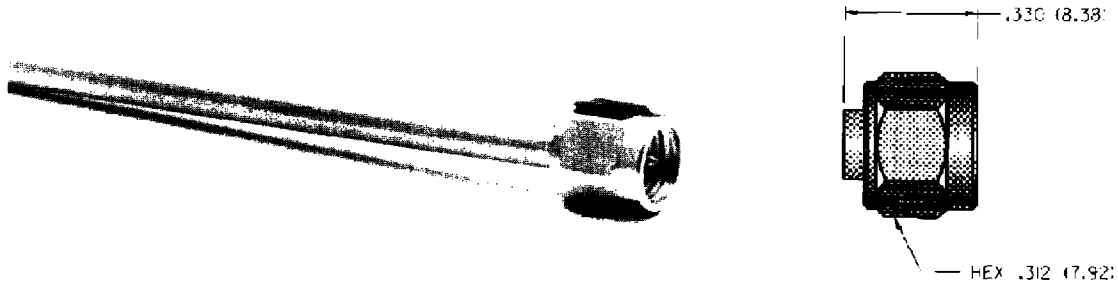

CABLE TYPE	VSWR & FREQ. RANGE	PRODUCT SERIES	GOLD PLATED	NICKEL PLATED	PASSIVATED (nut only)
.141 Semi-Rigid	1.035 + .005 f (GHz) 0-26.5 GHz	Brass	142-0694-021	142-0694-026	
		Stainless Steel	141-0694-021		141-0693-022

Assembly instructions page 105.

Center conductor of cable serves as contact.

Straight Solder Type Plug - without contact, slide-on notched nut

Thick wall connector interface

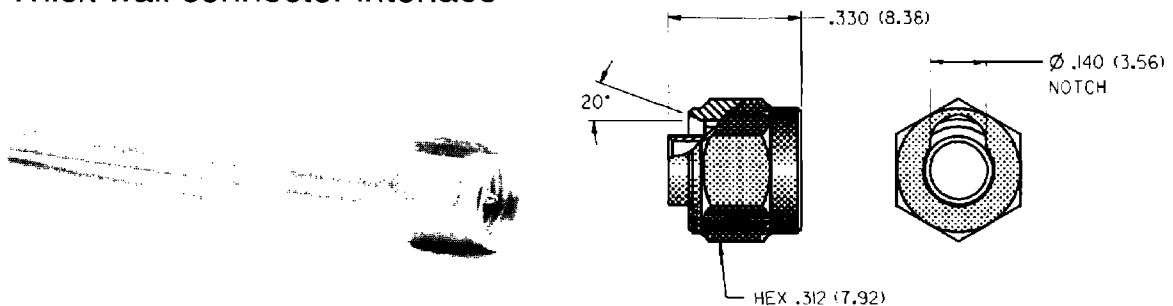

CABLE TYPE	VSWR & FREQ. RANGE	PRODUCT SERIES	GOLD PLATED	NICKEL PLATED	PASSIVATED (nut only)
.141 Semi-Rigid	1.035 + .005 f (GHz) 0-26.5 GHz	Brass	142-0694-041	142-0694-046	
		Stainless Steel	141-0694-041		141-0694-042

Assembly instructions page 105.

Center conductor of cable serves as contact.

Straight Solder Type Jack

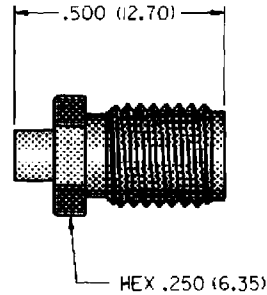

CABLE TYPE	VSWR & FREQ. RANGE	PRODUCT SERIES	GOLD PLATED	NICKEL PLATED
.086 Semi-Rigid	0-18 GHz: 1.07 + .008 f (GHz) 26.5 GHz: 1.35 Max	Brass	142-0593-001	142-0593-006
		Stainless Steel	141-0593-001	
.141 Semi-Rigid	0-26.5 GHz: 1.05+.008 f (GHz)	Brass	142-0594-001	142-0594-006
		Stainless Steel	141-0594-001	

Assembly instructions page 103.

Straight Solder Type Bulkhead Jack

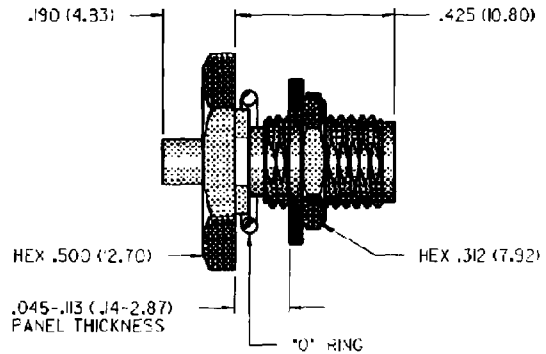
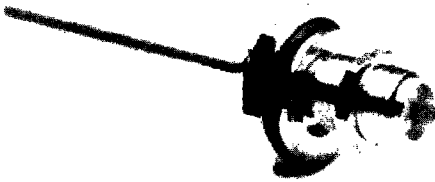

CABLE TYPE	VSWR & FREQ. RANGE	PRODUCT SERIES	GOLD PLATED	NICKEL PLATED
.086 Semi-Rigid	0-18 GHz: 1.07 + .008 f (GHz) 26.5 GHz: 1.35 Max	Brass	142-0593-401	142-0593-406
		Stainless Steel	141-0593-401	
.141 Semi-Rigid	0-26.5 GHz: 1.05+.008 f (GHz)	Brass	142-0594-401	142-0594-406
		Stainless Steel	141-0594-401	

Assembly Instructions page 103.

Mounting hole layout Figure 1 page 121.

SMA Connectors

PC Mount

JOHNSON
Components

Inches (millimeters)
customer drawings available upon request

Straight Plug Receptacle

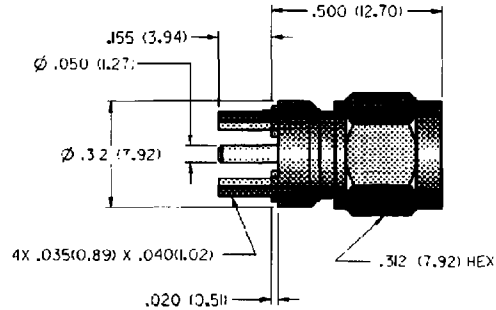

VSWR & FREQ. RANGE	PRODUCT SERIES	GOLD PLATED	NICKEL PLATED	PASSIVATED (nut only)
VSWR: N/A 0-18 GHz	Brass	142-0801-201	142-0801-206	
	Stainless Steel	141-0801-201		141-0801-202

Mounting hole layout figure 2 page 121.

Right Angle Plug Receptacle

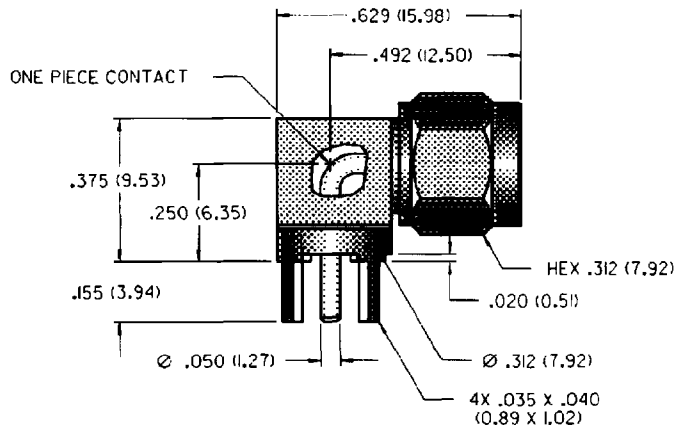
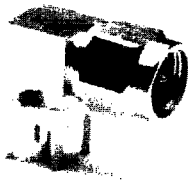

VSWR & FREQ. RANGE	PRODUCT SERIES	GOLD PLATED	NICKEL PLATED	PASSIVATED (nut only)
VSWR: N/A 0-18 GHz	Brass	142-0801-301	142-0801-306	
	Stainless Steel	141-0801-301		141-0801-302

Mounting hole layout figure 2 page 121.

Straight Jack Receptacle

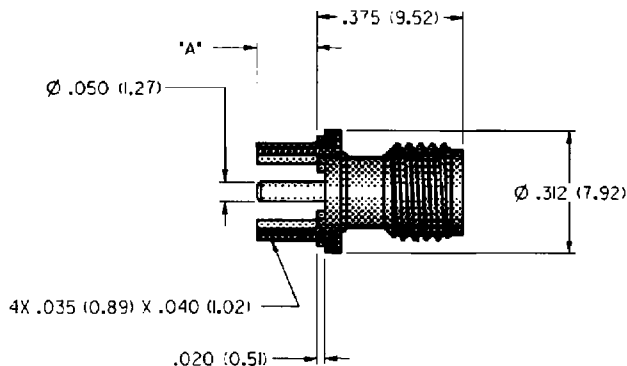

VSWR & FREQ. RANGE	PRODUCT SERIES	GOLD PLATED	NICKEL PLATED	IR COMPATIBLE	DIMENSION "A"
VSWR: N/A 0-18 GHz	Brass	142-0701-201	142-0701-206	142-0701-235*	.155 (3.94)
		142-0701-231	142-0701-236		.110 (2.79)
	Stainless Steel	141-0701-201			.155 (3.94)

* Tin/Lead solder dipped legs for IR Reflow Compatibility.
Mounting hole layout figure 2 page 121.

Straight Jack Receptacle - Surface Mount

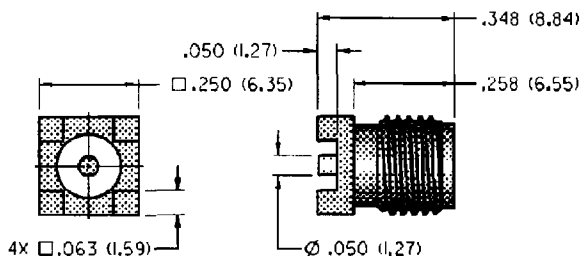
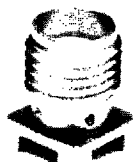

VSWR & FREQ. RANGE	PRODUCT SERIES	GOLD PLATED	NICKEL PLATED
VSWR: N/A 0-18 GHz	Brass	142-0711-201	142-0711-205Δ

Δ Connector Mounting Pads 60%/40% Tin/Lead Coated (Solder Plated)
Recommended Land Pattern figure 9 page 121.

SMA Connectors

PC Mount

JOHNSON
Components

Inches (millimeters)
customer drawings available upon request

Straight Bulkhead Jack Receptacle

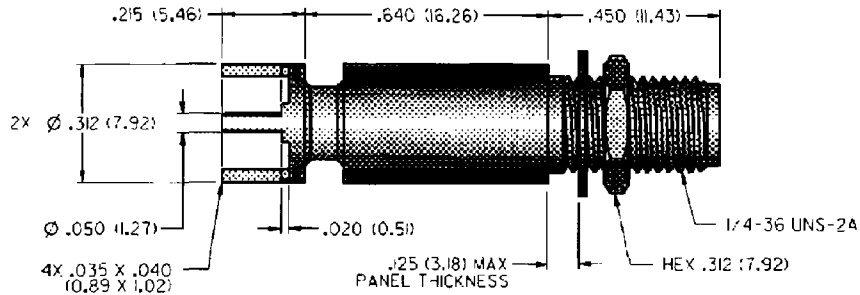

VSWR & FREQ. RANGE	PRODUCT SERIES	GOLD PLATED	NICKEL PLATED
VSWR: N/A 0-18 GHz	Brass	142-0701-421	142-0701-426

Mounting hole layout figure 2 page 121.

Right Angle Jack Receptacle

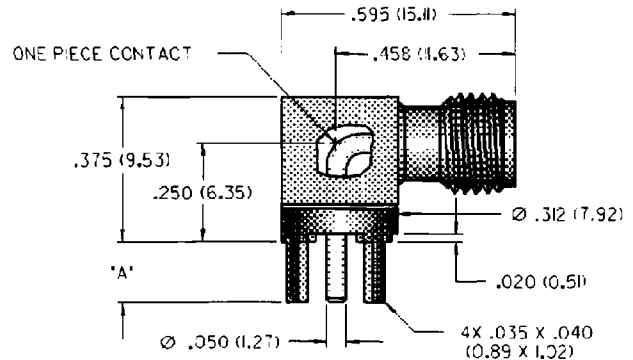
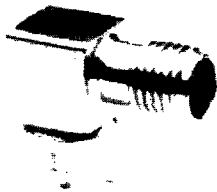

VSWR & FREQ. RANGE	PRODUCT SERIES	GOLD PLATED	NICKEL PLATED
VSWR: N/A 0-18 GHz	Brass	142-0701-301	142-0701-306
	Stainless Steel	141-0701-301	

Mounting hole layout figure 2 page 121.

Right Angle Jack Receptacle - Surface Mount

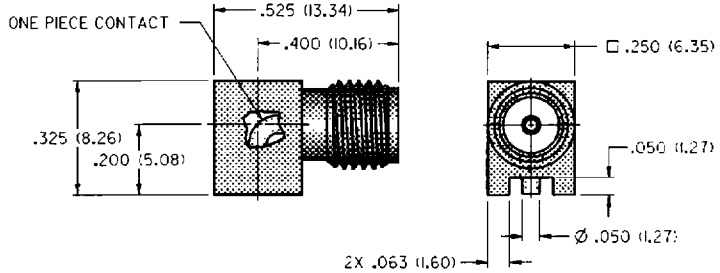

VSWR & FREQ. RANGE	PRODUCT SERIES	GOLD PLATED	NICKEL PLATED
VSWR: N/A 0-18 GHz	Brass	142-0711-301	42-0711-305 Δ

Δ Connector Mounting Rails 60%/40% Tin/Lead Coated (Solder Plated)
Recommended Land Pattern figure 9 page 121.

Right Angle Jack Receptacle - Moisture Seal*

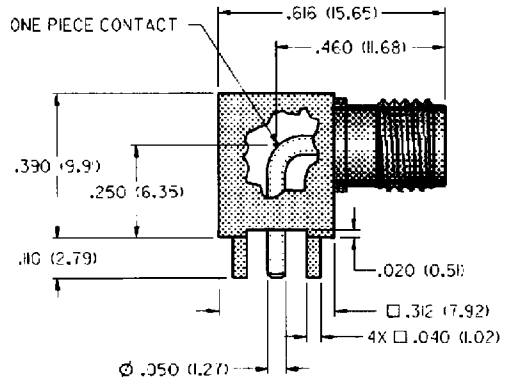
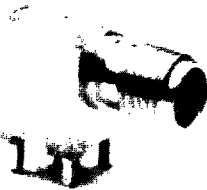

VSWR & FREQ. RANGE	NICKEL BODY, GOLD INTERFACE IR COMPATIBLE*
VSWR: N/A 0-18 GHz	142-0701-335*

* Tin/Lead solder dipped legs and Moisture Sealed for IR
Reflow Compatibility.
Mounting hole layout figure 2 page 121.

SMA Connectors

PC Mount

JOHNSON
Components

Inches (millimeters)
customer drawings available upon request

Right Angle Bulkhead Jack Receptacle

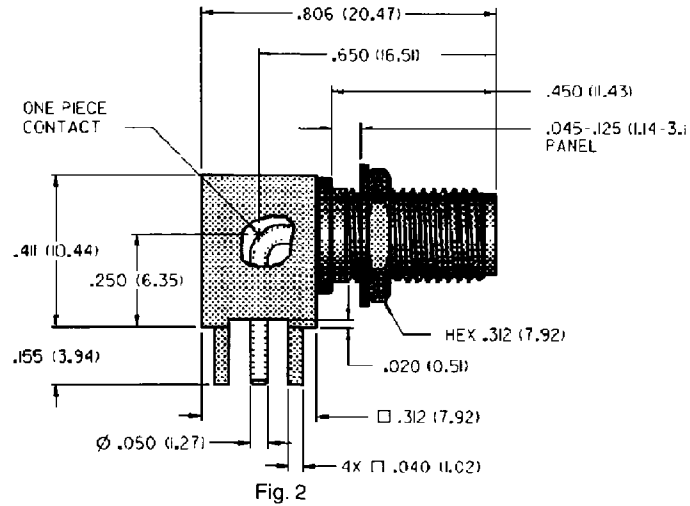
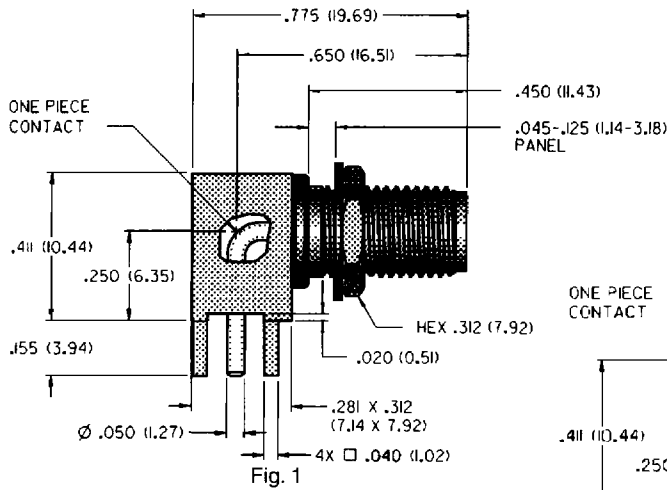
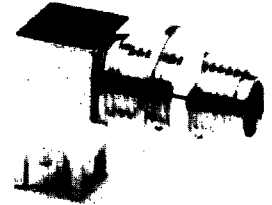

VSWR & FREQ. RANGE	PRODUCT SERIES	GOLD PLATED	NICKEL PLATED
VSWR: N/A 0-18 GHz	Brass (Fig.1)	142-0701-501	142-0701-506
	Stainless Steel (Fig.2)	141-0701-501	

Mounting hole layout figure 1 & 2 page 121.

End Launch Plug Receptacle - Round Contact

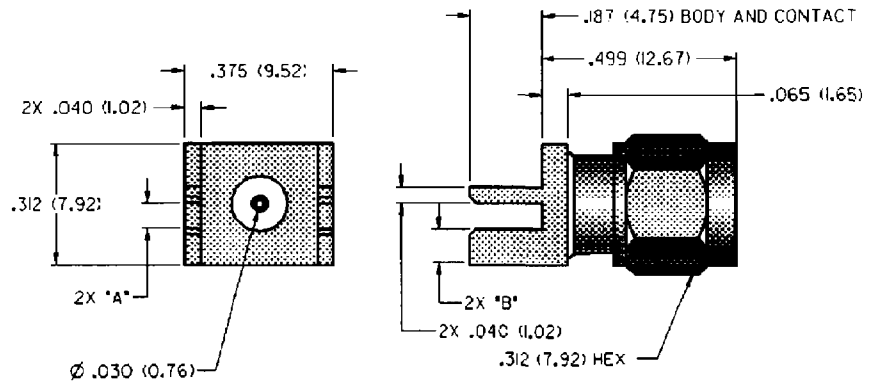

VSWR & FREQ. RANGE	PRODUCT SERIES	GOLD PLATED	NICKEL PLATED	DIMENSION "A"	DIMENSION "B"
VSWR: N/A 0-18 GHz	Brass	142-0801-801	142-0801-806	.068 (1.73)	.073 (1.85)
		142-0801-821	142-0801-826	.048 (1.22)	.093 (2.36)

End Launch Plug Receptacle - Tab Contact

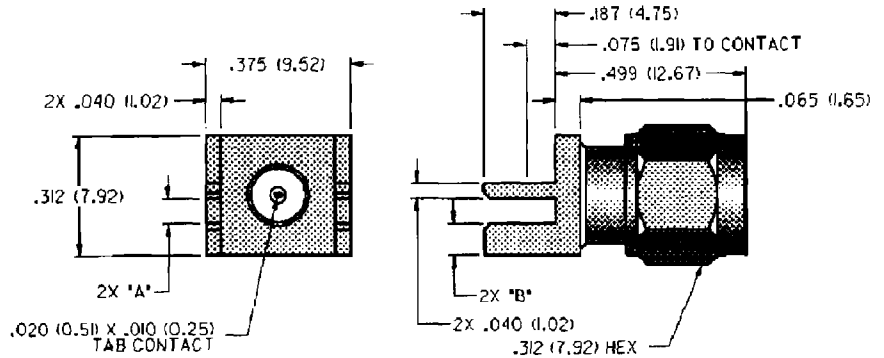

VSWR & FREQ. RANGE	PRODUCT SERIES	GOLD PLATED	NICKEL PLATED	DIMENSION "A"	DIMENSION "B"
VSWR: N/A 0-18 GHz	Brass	142-0801-811	142-0801-816	.068 (1.73)	.083 (2.11)
		142-0801-831	142-0801-836	.048 (1.22)	.103 (2.62)

End Launch Jack Receptacle - Round Contact

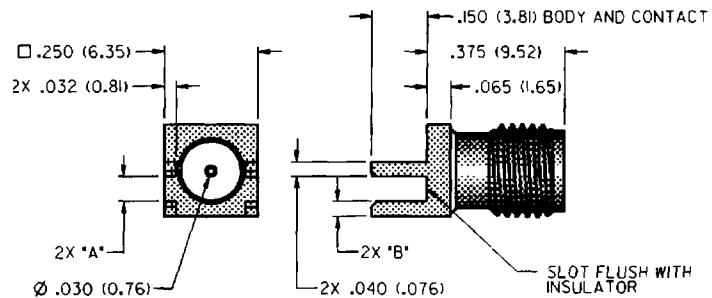

VSWR & FREQ. RANGE	PRODUCT SERIES	GOLD PLATED	NICKEL PLATED	DIMENSION "A"	DIMENSION "B"
VSWR: N/A 0-18 GHz	Brass	142-0711-821	142-0711-826	.068 (1.73)	.042 (1.07)
		142-0711-841	142-0711-846	.048 (1.22)	.062 (1.57)

Coupling proof torque 8 inch-pounds maximum.

SMA Connectors

PC Mount

JOHNSON
Components

Inches (millimeters)
customer drawings available upon request

End Launch Jack Receptacle - Round Contact

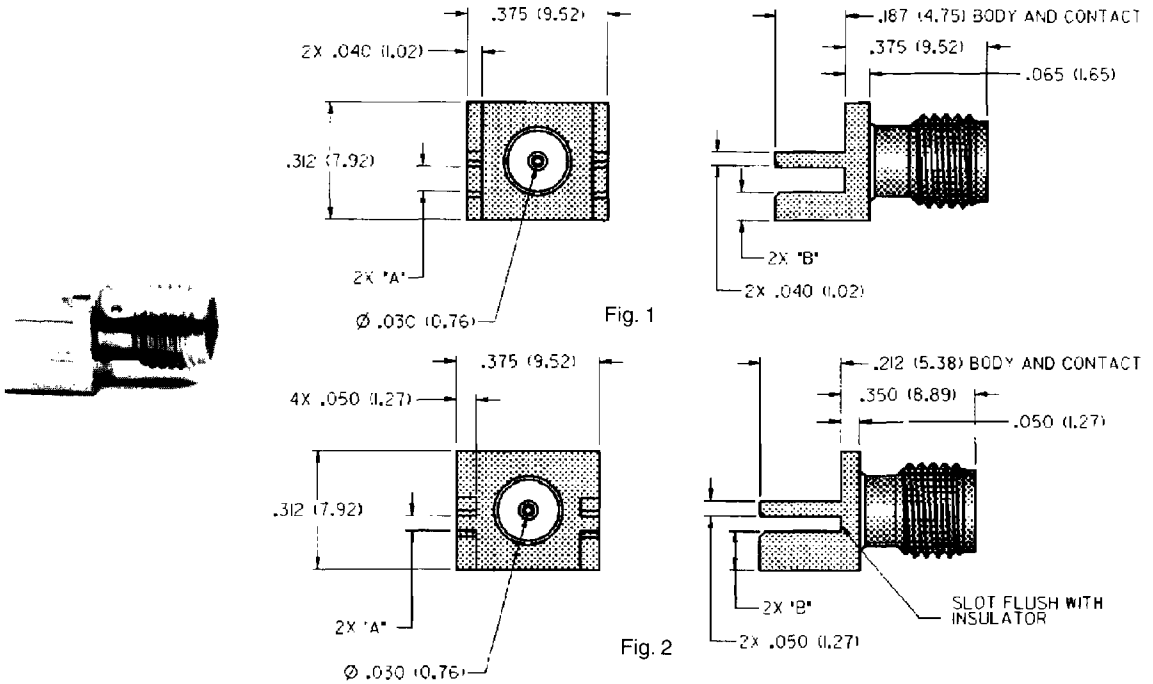

VSWR & FREQ. RANGE	PRODUCT SERIES	GOLD PLATED	NICKEL PLATED	DIMENSION "A"	DIMENSION "B"
VSWR: N/A 0-18 GHz	(Fig. 1)	142-0701-801	142-0701-806	.068 (1.73)	.073 (1.85)
	Brass (Fig. 1)	142-0701-831	142-0701-836	.048 (1.22)	.093 (2.36)
	(Fig. 2)	142-0701-881	142-0701-886	.037 (.94)	.104 (2.64)
	Stainless Steel (Fig. 1)	141-0701-801		.068 (1.73)	.073 (1.85)

End Launch Jack Receptacle - Tab Contact

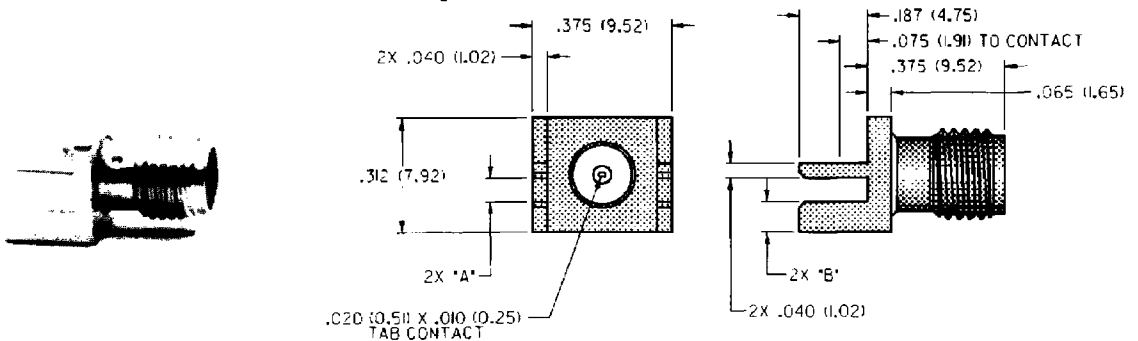

VSWR & FREQ. RANGE	PRODUCT SERIES	GOLD PLATED	NICKEL PLATED	DIMENSION "A"	DIMENSION "B"
VSWR: N/A 0-18 GHz	Brass	142-0701-851	142-0701-856	.068 (1.73)	.083 (2.11)
		142-0701-841	142-0701-846	.048 (1.22)	.103 (2.62)

End Launch Bulkhead Jack Receptacle - Round Contact

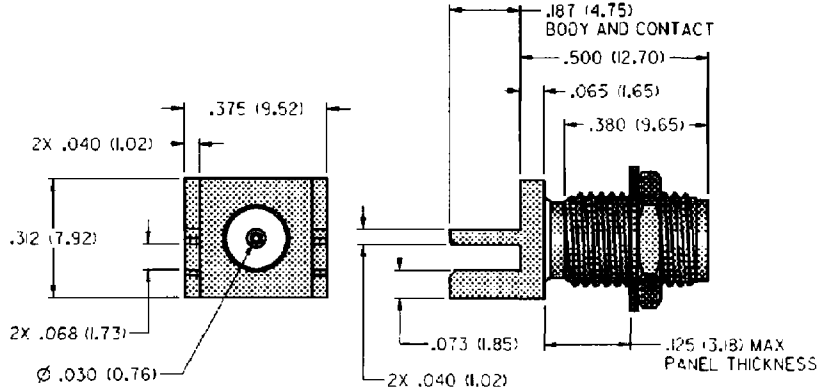

VSWR & FREQ. RANGE	PRODUCT SERIES	GOLD PLATED	NICKEL PLATED
		VSWR: N/A 0-18 GHz	Brass

End Launch Bulkhead Jack Receptacle - Round Contact

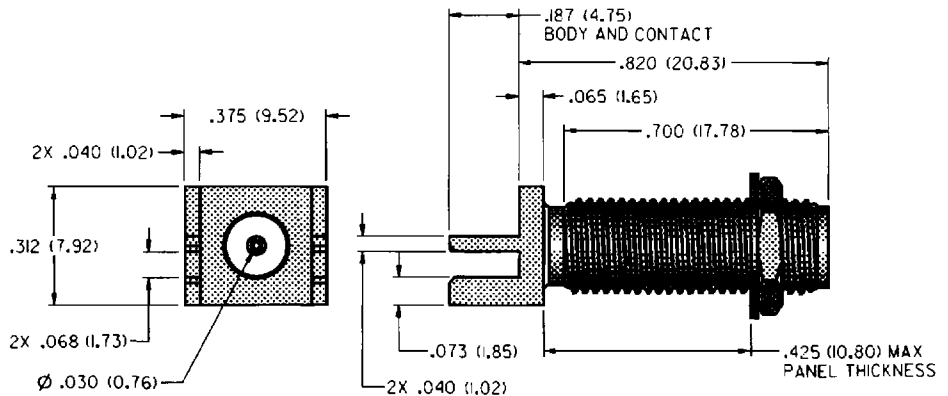

VSWR & FREQ. RANGE	PRODUCT SERIES	GOLD PLATED	NICKEL PLATED
		VSWR: N/A 0-18 GHz	Brass

SMA Connectors

For Flexible Cable

JOHNSON
Components

Inches (millimeters)

customer drawings available upon request

Straight Crimp Type Plug - Captivated Contact

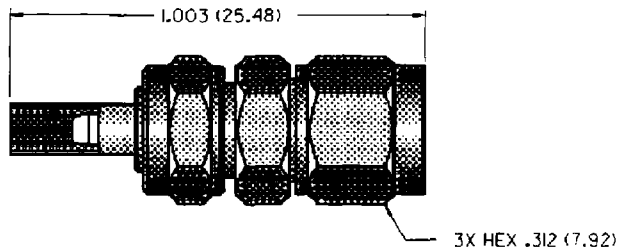

CABLE TYPE	VSWR & FREQ. RANGE	PRODUCT SERIES	GOLD PLATED	NICKEL PLATED	PASSIVATED
RG-178/U, 196	1.20 + .025 f (GHz) 0-12.4 GHz	Brass	142-0402-001	142-0402-006	
		Stainless Steel	141-0402-001		141-0402-002
RG-161/U, 174, 188, 316	1.15 + .02 f (GHz) 0-12.4 GHz	Brass	142-0403-001	142-0403-006	
		Stainless Steel	141-0403-001		141-0403-002
RG-188 DS RG-316 DS	1.15 + .02 f (GHz) 0-12.4 GHz	Brass	142-0404-001	142-0404-006	
		Stainless Steel	141-0404-001		141-0404-002
RG-58/U, 141, 303	1.15 + .01 f (GHz) 0-12.4 GHz	Brass	142-0407-001	142-0407-006	
		Stainless Steel	141-0407-001		141-0407-002
RG-55/U, 142, 223, 400	1.15 + .01 f (GHz) 0-12.4 GHz	Brass	142-0408-001	142-0408-006	
		Stainless Steel	141-0408-001		141-0408-002

Assembly instructions
page 110.
See page 95 for Cable
Assembly Tools.

Straight Crimp Type Plug (3-piece) - Solder or Crimp Captivated Contact

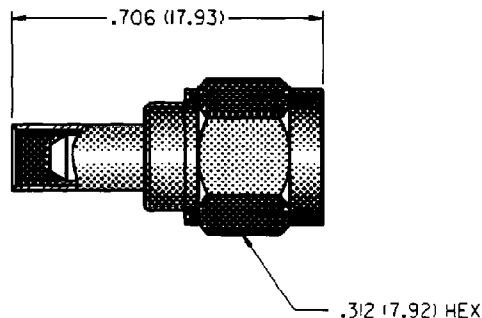

CABLE TYPE	VSWR & FREQ. RANGE	PRODUCT SERIES	GOLD PLATED	NICKEL PLATED	PASSIVATED
RG-161/U, 174, 188, 316	1.15 + .02 f (GHz) 0-12.4 GHz	Brass	142-0403-011	142-0403-016	
		Stainless Steel	141-0403-011		141-0403-012
RG-188 DS RG-316 DS	1.15 + .02 f (GHz) 0-12.4 GHz	Brass	142-0404-011	142-0404-016	
		Stainless Steel	141-0404-011		141-0404-012
RG-58/U, 141, 303	1.15 + .01 f (GHz) 0-12.4 GHz	Brass	142-0407-011	142-0407-016	
		Stainless Steel	141-0407-011		141-0407-012
RG-55/U, 142, 223, 400	1.15 + .01 f (GHz) 0-12.4 GHz	Brass	142-0408-011	142-0408-016	
		Stainless Steel	141-0408-011		141-0408-012
RG-179/U, 187	N/A	Brass	142-0433-011	142-0433-016	

Assembly instructions
page 109.
See pages 95 & 96 for
Cable Assembly Tools.
See page 93 for reverse
polarity or reverse
thread capabilities.

Right Angle Crimp Type Plug - Captivated Contact

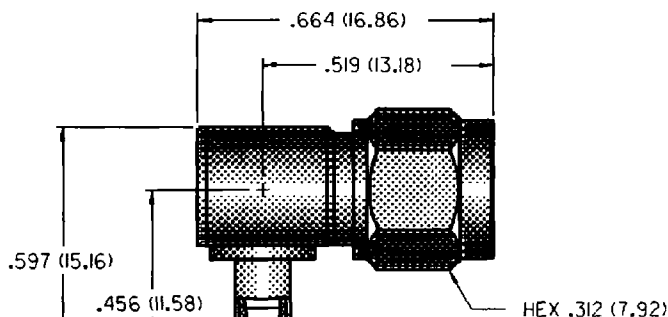

CABLE TYPE	VSWR & FREQ. RANGE	PRODUCT SERIES	GOLD PLATED	NICKEL PLATED	PASSIVATED
RG-178/U, 196	1.20 + .03 f (GHz) 0-12.4 GHz	Brass	142-0402-101	142-0402-106	
		Stainless Steel	141-0402-101		141-0402-102
RG-161/U, 174, 188, 316	1.15 + .03 f (GHz) 0-12.4 GHz	Brass	142-0403-101	142-0403-106	
		Stainless Steel	141-0403-101		141-0403-102
RG-188 DS RG-316 DS	1.15 + .03 f (GHz) 0-12.4 GHz	Brass	142-0404-101	142-0404-106	
		Stainless Steel	141-0404-101		141-0404-102
RG-58/U, 141, 303	1.15 + .02 f (GHz) 0-12.4 GHz	Brass	142-0407-101	142-0407-106	
		Stainless Steel	141-0407-101		141-0407-102
RG-55/U, 142, 223, 400	1.15 + .02 f (GHz) 0-12.4 GHz	Brass	142-0408-101	142-0408-106	
		Stainless Steel	141-0408-101		141-0408-102
RG-179/U, 187	N/A	Brass	142-0433-101	142-0433-106	

Assembly instructions
page 111.
See page 95 for Cable
Assembly Tools.

Straight Crimp Type Jack - Captivated Contact

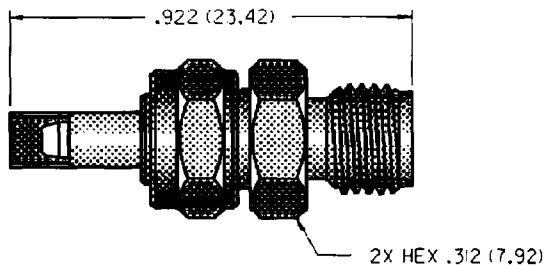
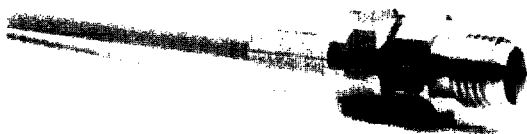

CABLE TYPE	VSWR & FREQ. RANGE	PRODUCT SERIES	GOLD PLATED	NICKEL PLATED	PASSIVATED
RG-178/U, 196	1.20 + .025 f (GHz) 0-12.4 GHz	Brass	142-0302-001	142-0302-006	
		Stainless Steel	141-0302-001		141-0302-002
RG-161/U, 174, 188, 316	1.15 + .02 f (GHz) 0-12.4 GHz	Brass	142-0303-001	142-0303-006	
		Stainless Steel	141-0303-001		141-0303-002
RG-188 DS RG-316 DS	1.15 + .02 f (GHz) 0-12.4 GHz	Brass	142-0304-001	142-0304-006	
		Stainless Steel	141-0304-001		141-0304-002
RG-58/U, 141, 303	1.15 + .01 f (GHz) 0-12.4 GHz	Brass	142-0307-001	142-0307-006	
		Stainless Steel	141-0307-001		141-0307-002
RG-55/U, 142, 223, 400	1.15 + .01 f (GHz) 0-12.4 GHz	Brass	142-0308-001	142-0308-006	
		Stainless Steel	141-0308-001		141-0308-002

Assembly instructions
page 110.
See page 95 for Cable
Assembly Tools.

SMA Connectors

For Flexible Cable

JOHNSON
Components

Inches (millimeters)
customer drawings available upon request

Straight Crimp Type Jack (3-piece) - Solder or Crimp Captivated Contact

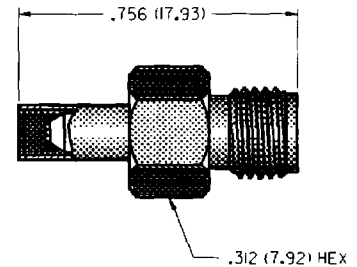

CABLE TYPE	VSWR & FREQ. RANGE	PRODUCT SERIES	GOLD PLATED	NICKEL PLATED	PASSIVATED
RG-161/U, 174, 188, 316	1.15 + .02 f (GHz) 0-12.4 GHz	Brass	142-0303-011	142-0303-016	
		Stainless Steel	141-0303-011		141-0303-012
RG-188 DS RG-316 DS	1.15 + .02 f (GHz) 0-12.4 GHz	Brass	142-0304-011	142-0304-016	
		Stainless Steel	141-0304-011		141-0304-012
RG-58/U, 141, 303	1.15 + .01 f (GHz) 0-12.4 GHz	Brass	142-0307-011	142-0307-016	
		Stainless Steel	141-0307-011		141-0307-012
RG-55/U, 142, 223, 400	1.15 + .01 f (GHz) 0-12.4 GHz	Brass	142-0308-011	142-0308-016	
		Stainless Steel	141-0308-011		141-0308-012
RG-179, 187	N/A	Brass	142-0333-011	142-0333-016	

Assembly instructions page 109.
See pages 95 and 96 for Cable Assembly Tools.
See page 93 for reverse polarity or reverse thread capabilities.

Straight Crimp Type Bulkhead Jack - Captivated Contact

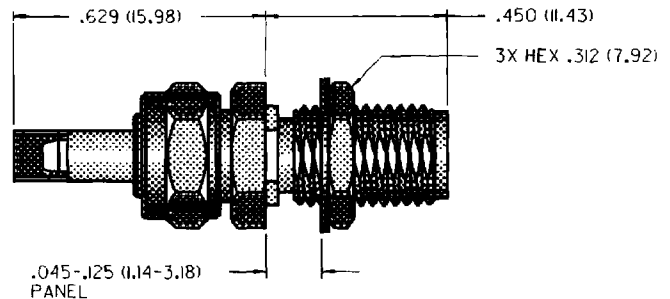

CABLE TYPE	VSWR & FREQ. RANGE	PRODUCT SERIES	GOLD PLATED	NICKEL PLATED	PASSIVATED
RG-178/U, 196	1.20 + .025 f (GHz) 0-12.4 GHz	Brass	142-0302-401	142-0302-406	
		Stainless Steel	141-0302-401		141-0302-402
RG-161/U, 174, 188, 316	1.15 + .02 f (GHz) 0-12.4 GHz	Brass	142-0303-401	142-0303-406	
		Stainless Steel	141-0303-401		141-0303-402
RG-188 DS RG-316 DS	1.15 + .02 f (GHz) 0-12.4 GHz	Brass	142-0304-401	142-0304-406	
		Stainless Steel	141-0304-401		141-0304-402
RG-58/U, 141, 303	1.15 + .01 f (GHz) 0-12.4 GHz	Brass	142-0307-401	142-0307-406	
		Stainless Steel	141-0307-401		141-0307-402
RG-55/U, 142, 223, 400	1.15 + .01 f (GHz) 0-12.4 GHz	Brass	142-0308-401	142-0308-406	
		Stainless Steel	141-0308-401		141-0308-402

Assembly instructions page 110.
Mounting Hole layout figure 1 page 121.
See page 95 for Cable Assembly Tools.

Straight Crimp Type Bulkhead Jack (3-piece) - Solder or Crimp Captivated Contact

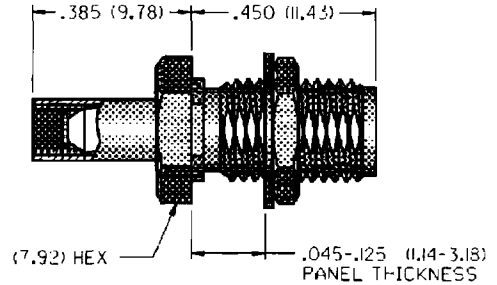

Assembly instructions page 109.
Mounting hole layout figure 1 page 121.
See pages 95 & 96 for Cable Assembly Tools.
See page 93 for reverse polarity or reverse thread capabilities.

CABLE TYPE	VSWR & FREQ. RANGE	PRODUCT SERIES	GOLD PLATED	NICKEL PLATED	PASSIVATED
RG-161/U, 174, 188, 316	1.15 + .02 f (GHz) 0-12.4 GHz	Brass	142-0303-411	142-0303-416	
		Stainless Steel	141-0303-411		141-0303-412
RG-188 DS RG-316 DS	1.15 + .02 f (GHz) 0-12.4 GHz	Brass	142-0304-411	142-0304-416	
		Stainless Steel	141-0304-411		141-0304-412
RG-58/U, 141, 303	1.15 + .01 f (GHz) 0-12.4 GHz	Brass	142-0307-411	142-0307-416	
		Stainless Steel	141-0307-411		141-0307-412
RG-55/U, 142, 223, 400	1.15 + .01 f (GHz) 0-12.4 GHz	Brass	142-0308-411	142-0308-416	
		Stainless Steel	141-0308-411		141-0308-412
RG-179U/, 187	N/A	Brass	142-0333-411	142-0333-416	

Straight Clamp Type Plug - Captivated Contact

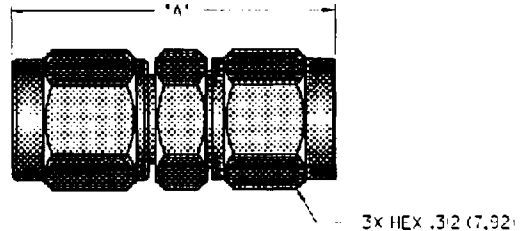
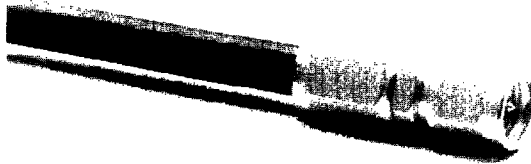

Assembly instructions page 114.
Mounting hole layout figure 1 page 121.

CABLE TYPE	VSWR & FREQ. RANGE	PRODUCT SERIES	GOLD PLATED	NICKEL PLATED	PASSIVATED
RG-178/U, 196 "A" = .826(20.98)	.20 + .025 f (GHz) 0-12.4 GHz	Brass	142-0202-011	142-0202-016	
		Stainless Steel	141-0202-001		141-0202-002
RG-161/U, 174, 188, 316 "A" = .861(21.87)	1.15 + .02 f (GHz) 0-12.4 GHz	Brass	142-0203-011	142-0203-016	
		Stainless Steel	141-0203-001		141-0203-002
RG-58/U, 141, 303, 55, 142, 223, 400 "A" = .895(22.73)	1.15 + .01 f (GHz) 0-12.4 GHz	Brass	142-0207-011	142-0207-016	
		Stainless Steel	141-0207-001		141-0207-002

SMA Connectors

For Flexible Cable

JOHNSON
Components

Inches (millimeters)
customer drawings available upon request

Right Angle Clamp Type Plug - Captivated Contact

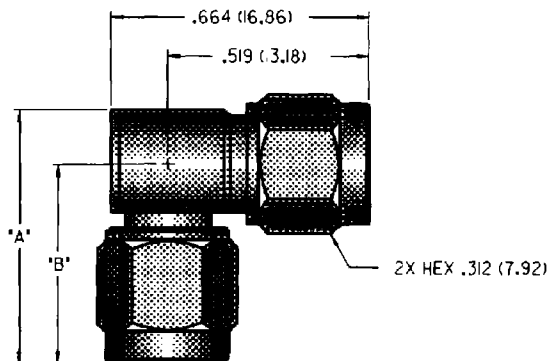

CABLE TYPE	VSWR & FREQ. RANGE	PRODUCT SERIES	GOLD PLATED	NICKEL PLATED	PASSIVATED
RG-178/U, 196 "A" = .569(14.45) "B" = .428(10.81)	1.20 + .03 f (GHz) 0-12.4 GHz	Brass	142-0202-101	142-0202-106	
		Stainless Steel	141-0202-101		141-0202-102
RG-161/U, 174, 188, 316 "A" = .574 (14.58) "B" = .433(11.00)	1.15 + .03 f (GHz) 0-12.4 GHz	Brass	142-0203-101	142-0203-106	
		Stainless Steel	141-0203-101		141-0203-102
RG-58/U, 141, 303, 55, 142, 223, 400 "A" = .686 (17.42) "B" = .545(13.84)	1.15 + .02 f (GHz) 0-12.4 GHz	Brass	142-0207-101	142-0207-106	
		Stainless Steel	141-0207-101		141-0207-102

Assembly instructions page 115.

Straight Clamp Type Jack - Captivated Contact

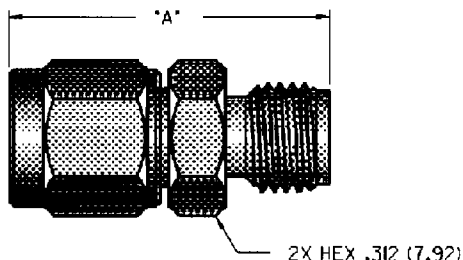
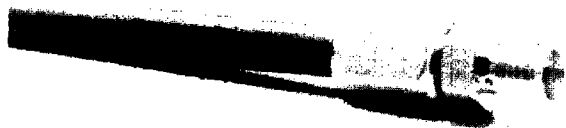

CABLE TYPE	VSWR & FREQ. RANGE	PRODUCT SERIES	GOLD PLATED	NICKEL PLATED	PASSIVATED
RG-178/U, 196 "A" = .745(18.92)	1.20 + .025 f (GHz) 0-12.4 GHz	Brass	142-0102-011	142-0102-016	
		Stainless Steel	141-0102-001		141-0102-002
RG-161/U, 174, 188, 316 "A" = .780(19.81)	1.15 + .02 f (GHz) 0-12.4 GHz	Brass	142-0103-011	142-0103-016	
		Stainless Steel	141-0103-001		141-0103-002
RG-58/U, 141, 303, 55, 142, 223, 400 "A" = .824(20.93)	1.15 + .01 f (GHz) 0-12.4 GHz	Brass	142-0107-011	142-0107-016	
		Stainless Steel	141-0107-001		141-0107-002

Assembly instructions page 114.

Straight Clamp Type Bulkhead Jack - Captivated Contact

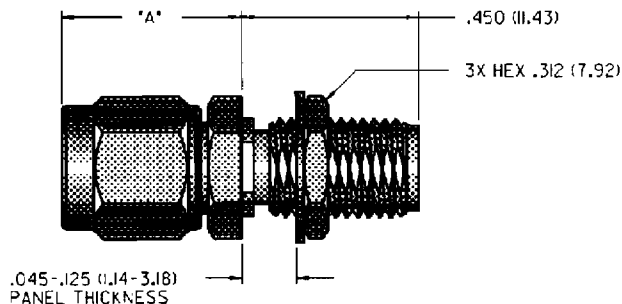
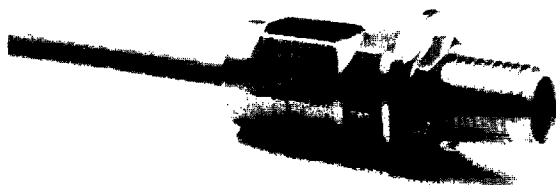

CABLE TYPE	VSWR & FREQ. RANGE	PRODUCT SERIES	GOLD PLATED	NICKEL PLATED	PASSIVATED
RG-178/U, 196 "A" = .452(11.48))	1.20 + .025 f (GHz) 0-12.4 GHz	Brass	142-0102-401	142-0102-406	
		Stainless Steel	141-0102-401		141-0102-402
RG-161/U, 174, 188, 316 "A" = .487(12.37)	1.15 + .02 f (GHz) 0-12.4 GHz	Brass	142-0103-401	142-0103-406	
		Stainless Steel	141-0103-401		141-0103-402
RG-58/U, 141, 303, 55, 142, 223, 400 "A" = .531(13.49)	1.15 + .01 f (GHz) 0-12.4 GHz	Brass	142-0107-401	142-0107-406	
		Stainless Steel	141-0107-401		141-0107-402

Assembly instructions page 114.
Mounting hole layout figure 1 page 121.

SMA Connectors

Bulkhead Mount

JOHNSON
Components

Inches (millimeters)
customer drawings available upon request

Rear Mount Bulkhead Plug - Antenna Connector

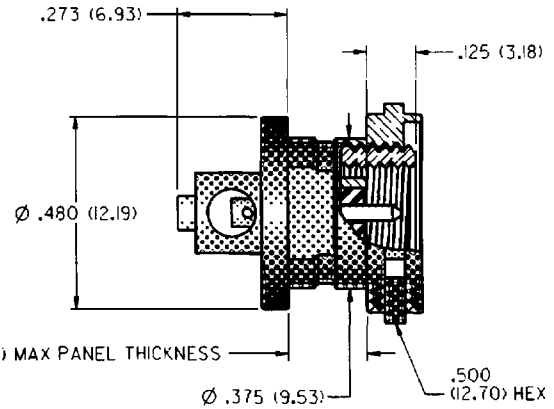

CABLE TYPE	VSWR & FREQ. RANGE	PRODUCT SERIES	GOLD PLATED*
RG-178/U .047 Semi-Rigid	VSWR: N/A 0-4 GHz	Brass	142-0801-421*

*With Nickel mounting nut. Assembly instructions page 108.
Mounting hole layout figure 8 page 121.
Mates with SMA Jack Antenna Interface.

Front Mount Bulkhead Jack Receptacle

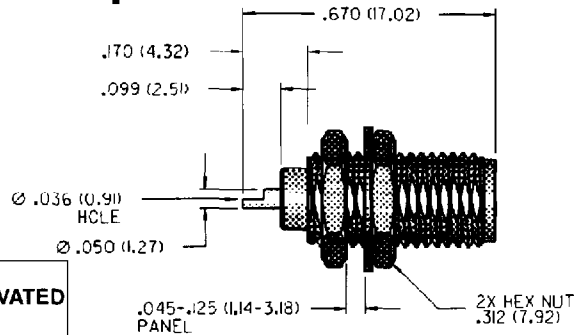

VSWR & FREQ. RANGE	PRODUCT SERIES	GOLD PLATED	NICKEL PLATED	PASSIVATED
VSWR: N/A 0-18 GHz	Brass	142-0701-411	142-0701-416	
	Stainless Steel	141-0701-411		141-0701-412

Mounting hole layout figure 1 page 121.

Rear Mount Bulkhead Jack Receptacle

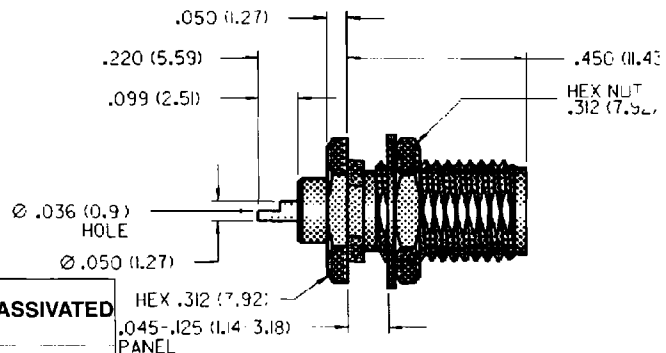

VSWR & FREQ. RANGE	PRODUCT SERIES	GOLD PLATED	NICKEL PLATED	PASSIVATED
VSWR: N/A 0-18 GHz	Brass	142-0701-401	142-0701-406	
	Stainless Steel	141-0701-401		141-0701-402

Mounting hole layout figure 1 page 121.

2-Hole Flange Mount Jack Receptacle - Flush Dielectric

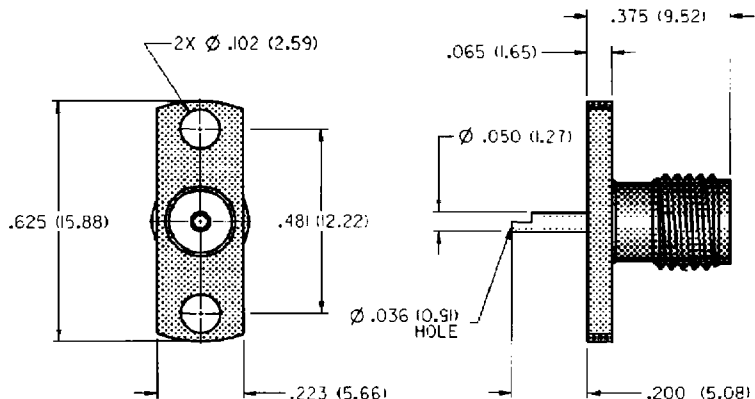

VSWR & FREQ. RANGE	PRODUCT SERIES	GOLD PLATED	NICKEL PLATED	PASSIVATED
VSWR: N/A 0-18 GHz	Brass	142-0701-621	142-0701-626	
	Stainless Steel	141-0701-601		141-0701-602

4-Hole Flange Mount Jack Receptacle - Flush Dielectric

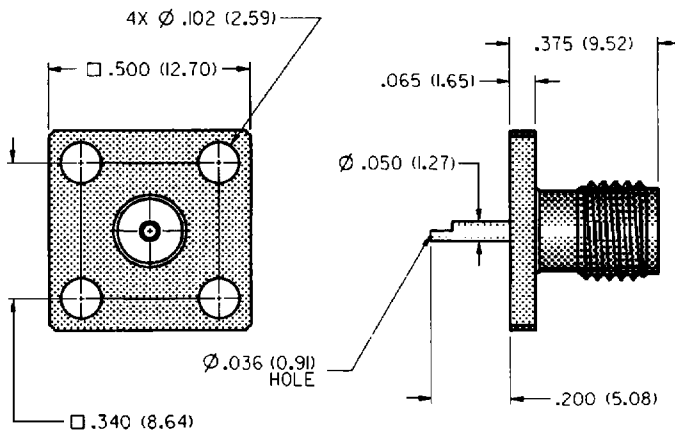

VSWR & FREQ. RANGE	PRODUCT SERIES	GOLD PLATED	NICKEL PLATED	PASSIVATED
VSWR: N/A 0-18 GHz	Brass	142-0701-631	142-0701-636	
	Stainless Steel	141-0701-611		141-0701-612

SMA Connectors

Panel Mount

JOHNSON
Components

Inches (millimeters)
customer drawings available upon request

2-Hole Flange Mount Plug Receptacle - Flush Dielectric

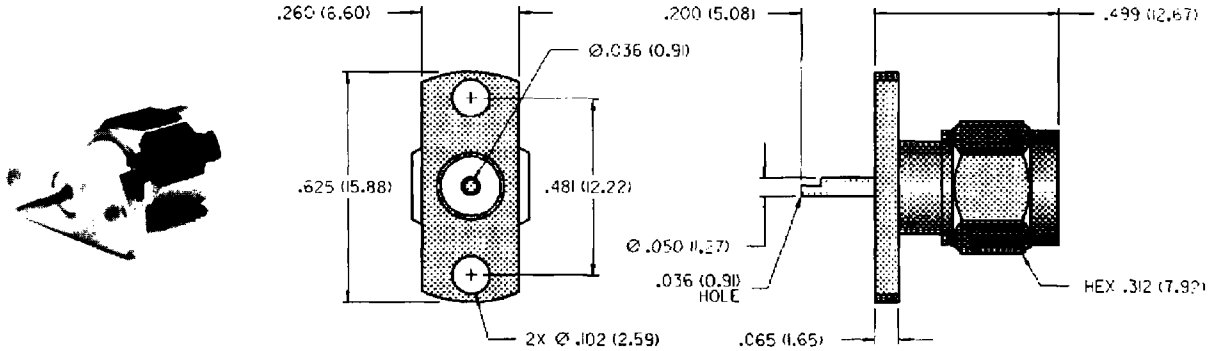

VSWR & FREQ. RANGE	PRODUCT SERIES	GOLD PLATED	NICKEL PLATED	PASSIVATED
VSWR: N/A 0-18 GHz	Brass	142-0801-601	142-0801-606	
	Stainless Steel	141-0801-601		141-0801-602

4-Hole Flange Mount Plug Receptacle - Flush Dielectric

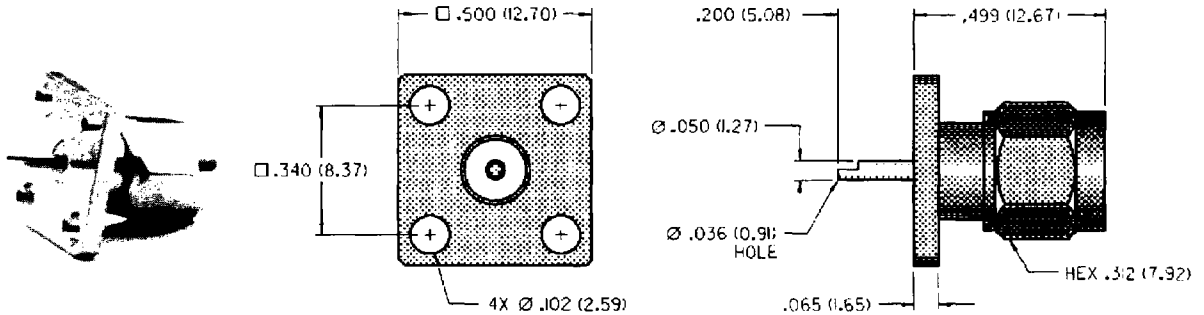

VSWR & FREQ. RANGE	PRODUCT SERIES	GOLD PLATED	NICKEL PLATED	PASSIVATED
VSWR: N/A 0-18 GHz	Brass	142-0801-611	142-0801-616	
	Stainless Steel	141-0801-611		141-0801-612

2-Hole Flange Mount Jack Receptacle - Extended Dielectric

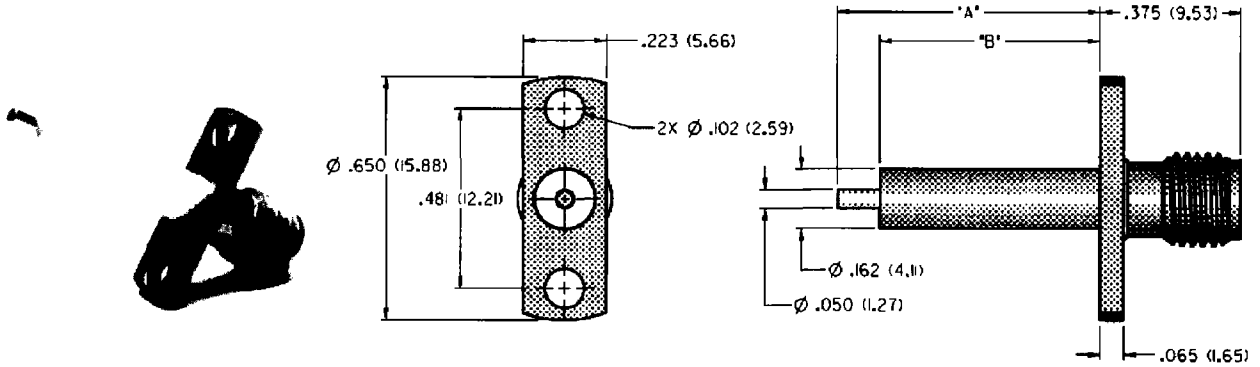

VSWR & FREQ. RANGE	PRODUCT SERIES	GOLD PLATED	NICKEL PLATED	DIMENSION "A"	DIMENSION "B"
VSWR: 1.15 + .02 f (GHz) 0-18 GHz	Brass	142-1701-131	142-1701-136	.705 (17.91)	.590 (14.99)
		142-1701-031	142-1701-036	.240 (6.10)	.180 (4.57)

4-Hole Flange Mount Jack Receptacle - Extended Dielectric

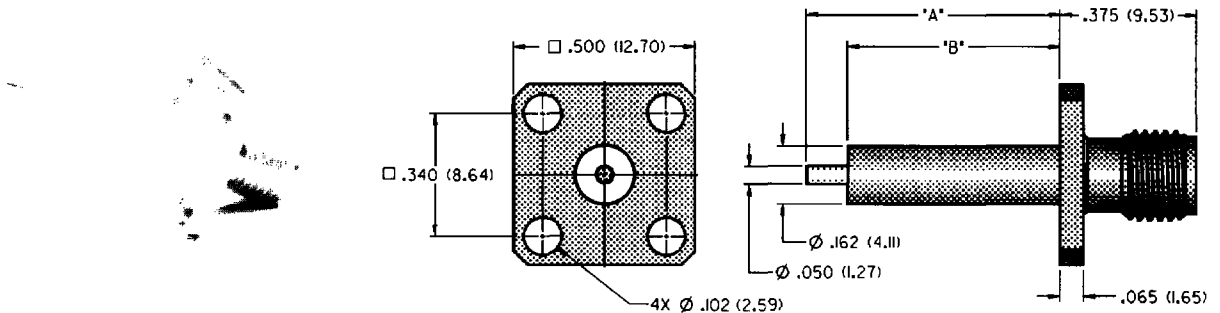

VSWR & FREQ. RANGE	PRODUCT SERIES	GOLD PLATED	NICKEL PLATED	DIMENSION "A"	DIMENSION "B"
VSWR: 1.15 + .02 f (GHz) 0-18 GHz	Brass	142-1701-121	142-1701-126	.705 (17.91)	.590 (14.99)
		142-1701-041	142-1701-046	.190 (4.83)	.095 (2.41)

SMA Connectors

Panel Mount

JOHNSON
Components

Inches (millimeters)
customer drawings available upon request

4-Hole Flange Mount Jack Receptacle - Extended Dielectric

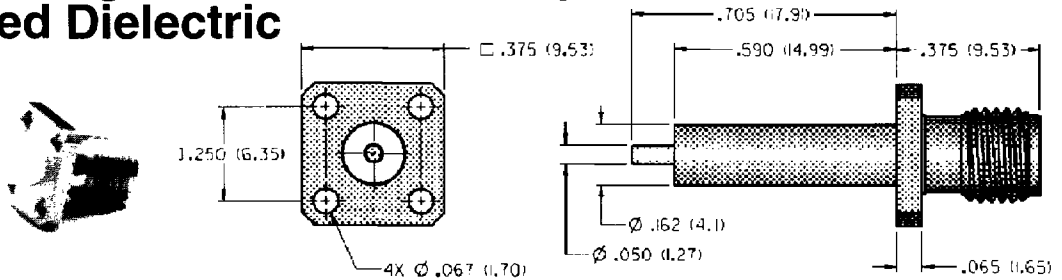

VSWR & FREQ. RANGE	PRODUCT SERIES	GOLD PLATED	NICKEL PLATED
VSWR: 1.15 + .02 f (GHz) 0-18 GHz	Brass	142-1701-011	142-1701-016

2-Hole Flange Mount Plug Receptacle - Extended Dielectric

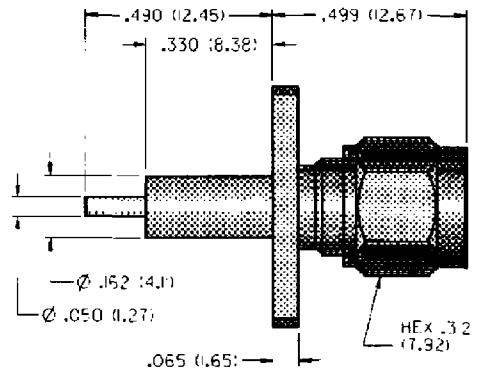
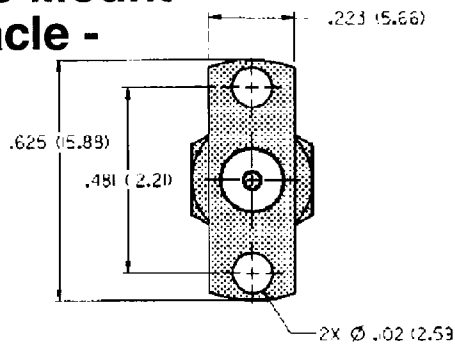

VSWR & FREQ. RANGE	PRODUCT SERIES	GOLD PLATED	NICKEL PLATED
VSWR: 1.15 + .02 f (GHz) 0-18 GHz	Brass	142-1801-041	142-1801-046

4-Hole Flange Mount Plug Receptacle - Extended Dielectric

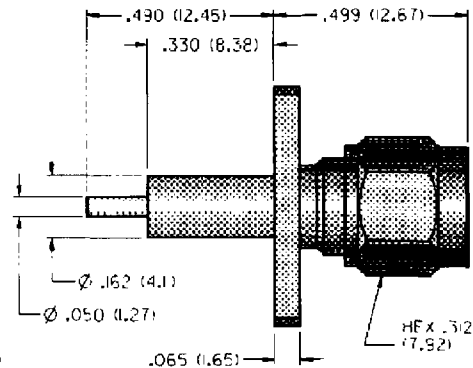
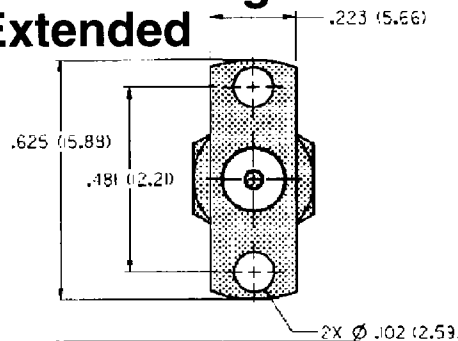

VSWR & FREQ. RANGE	PRODUCT SERIES	GOLD PLATED	NICKEL PLATED
VSWR: 1.15 + .02 f (GHz) 0-18 GHz	Brass	142-1801-031	142-1801-036

The field replaceable style of connector is known by many names in the industry, such as MIC launcher, hermetic seal launcher, spark plug launcher, etc. Some types, such as those known as "spark plugs", have the hermetic seal incorporated into the connector. These types require special welding to install and can not be replaced without destroying the hermeticity of the circuit housing. True field replaceable connectors, such as those manufactured by Johnson Components, are easy to install and replace. Because the hermetic seal is not incorporated into the connector design, the connector can be removed and replaced without destroying the hermetic seal or the hermeticity of the circuit housing.

All of the above mentioned connector types perform the same basic function - creating a transition from microstrip circuitry to a coaxial transmission line. Whenever possible, the hermetic seal pin diameter should be chosen as close as possible to the microstrip trace width. For optimum electrical performance, the transition from the hermetic seal to the microstrip trace must be properly compensated. Compensation involves adjusting the microstrip trace width to minimize any impedance discontinuities found in the transition area.

The plot shown below is representative of the typical return loss of an Johnson Components field replaceable connector. To produce the data shown below, a test fixture is created using the appropriate Johnson Components hermetic seal. The fixture consists of a suitably thick spacer plate with the hermetic seal mounted flush to both surfaces. Two connectors are mounted back to back around the fixture and the VSWR of this test assembly is measured. The return loss data shown is equivalent to the square root of the measured VSWR of the test assembly. Since the connectors tested are of identical design, it can be stated with fair accuracy that the data shown represents the response of a single field replaceable connector and its transition to the hermetic seal.

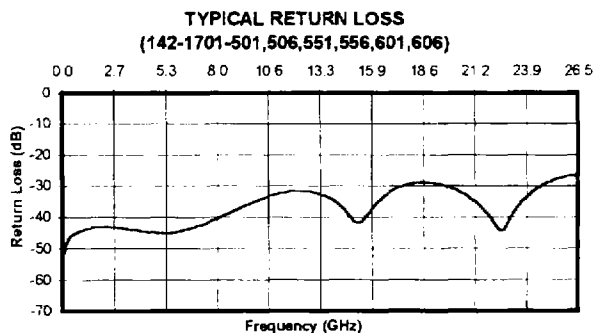
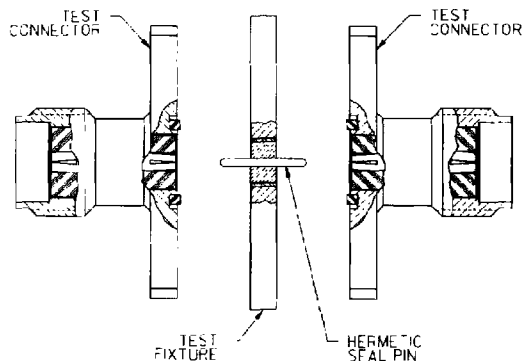

Although Johnson Components does not publish a VSWR specification for field replaceable connectors, typical connector VSWR can be expected to be less than $1.1 + .01f$ (f in GHz). A VSWR specification is not stated because an industry standard method for testing field replaceable connectors does not exist. The actual performance of the connector is dependent upon the application for the following reasons:

1. The choice of hermetic seal to be used by the customer is not specified by the connector manufacturer. Hermetic seals produced by different manufacturers will not have the same electrical characteristics. For optimum electrical performance, Johnson Components recommends the use of our standard 142-1000-001, 002, 003 and 004 hermetic seals for pin diameters of .012, .015, .018 and .020. Custom hermetic seal configurations can be quoted.
2. It is recommended that the hermetic seal be mounted flush with the circuit housing. Tolerance variations between the hermetic seal and machined housing do not always guarantee an optimum transition to the connector. Some manufacturers recommend an additional counterbore in the circuit housing to accommodate a solder washer during installation of the seal. Johnson Components does not recommend this type of installation because if the counterbore is not completely filled with solder, electrical discontinuities may be created.
3. The transition between the hermetic seal pin and the microstrip trace will affect electrical performance, as stated above. Several different methods of hermetic seal mounting and seal pin to microstrip trace attachment are used in the industry. Johnson Components can not recommend one method over the other as this is dependent upon the customer's application.

As always, quotes for non-standard field replaceable connectors and/or hermetic seals are welcome.

SMA Connectors

Field Replaceable

JOHNSON
Components

Inches (millimeters)
customer drawings available upon request

2-Hole Flange Mount Jack Receptacle With EMI Gasket

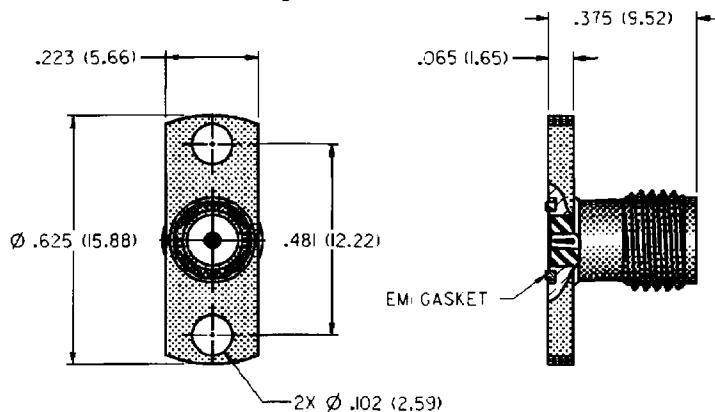

ACCEPTS PIN SIZE	FREQUENCY RANGE	PRODUCT SERIES	GOLD PLATED	NICKEL PLATED
.012	0-26.5 GHz	Brass	142-1701-601	142-1701-606
.015	0-26.5 GHz	Brass	142-1701-611	142-1701-616
.018	0-26.5 GHz	Brass	142-1701-621	142-1701-626

2-Hole Flange Mount Jack Receptacle Without EMI Gasket

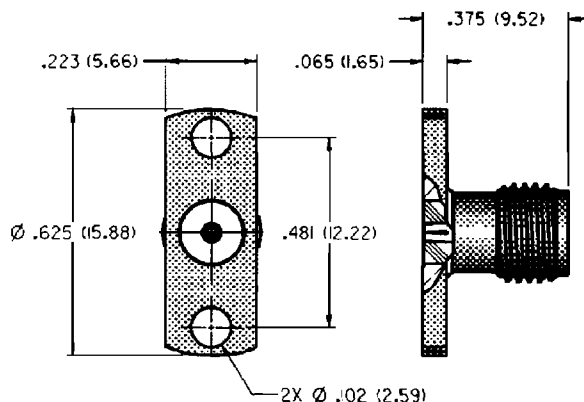

ACCEPTS PIN SIZE	FREQUENCY RANGE	PRODUCT SERIES	GOLD PLATED	NICKEL PLATED
.020	0-26.5 GHz	Brass	142-1701-631	142-1701-636
.036	0-26.5 GHz	Brass	142-1701-641	142-1701-646

4-Hole Flange Mount Jack Receptacle With EMI Gasket

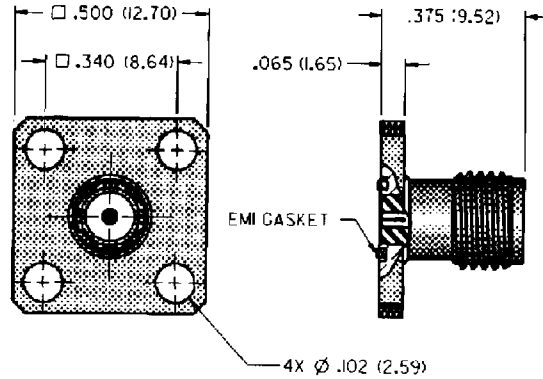

ACCEPTS PIN SIZE	FREQUENCY RANGE	PRODUCT SERIES	GOLD PLATED	NICKEL PLATED
.012	0-26.5 GHz	Brass	142-1701-501	142-1701-506
.015	0-26.5 GHz	Brass	142-1701-511	142-1701-516
.018	0-26.5 GHz	Brass	142-1701-521	142-1701-526

4-Hole Flange Mount Jack Receptacle Without EMI Gasket

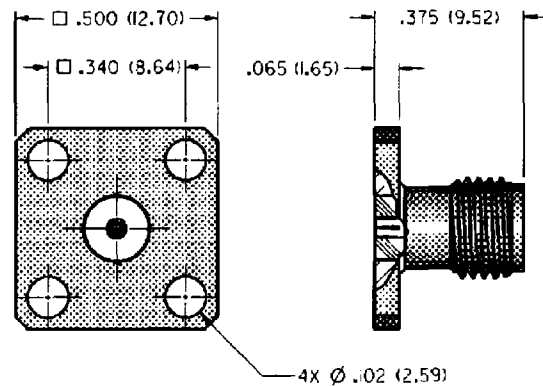

ACCEPTS PIN SIZE	FREQUENCY RANGE	PRODUCT SERIES	GOLD PLATED	NICKEL PLATED
.020	0-26.5 GHz	Brass	142-1701-531	142-1701-536
.036	0-26.5 GHz	Brass	142-1701-541	142-1701-546

SMA Connectors

Field Replaceable

JOHNSON
Components

Inches (millimeters)
customer drawings available upon request

4-Hole Flange Mount Jack Receptacle With EMI Gasket

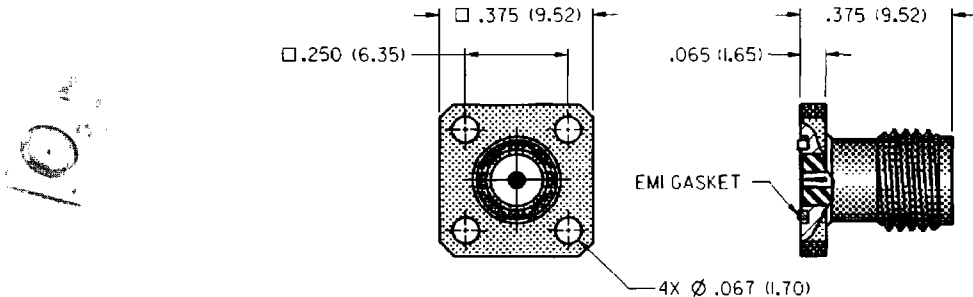

ACCEPTS PIN SIZE	FREQUENCY RANGE	PRODUCT SERIES	GOLD PLATED	NICKEL PLATED
.012	0-26.5 GHz	Brass	142-1701-551	142-1701-556
.015	0-26.5 GHz	Brass	142-1701-561	142-1701-566
.018	0-26.5 GHz	Brass	142-1701-571	142-1701-576

4-Hole Flange Mount Jack Receptacle Without EMI Gasket

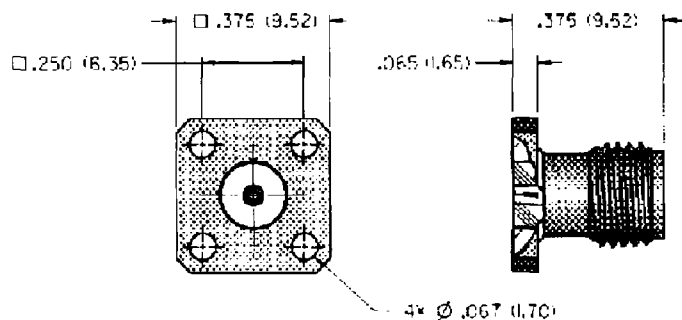

ACCEPTS PIN SIZE	FREQUENCY RANGE	PRODUCT SERIES	GOLD PLATED	NICKEL PLATED
.020	0-26.5 GHz	Brass	142-1701-581	142-1701-586
.036	0-26.5 GHz	Brass	142-1701-591	142-1701-596

2-Hole Flange Mount Plug Receptacle With EMI Gasket

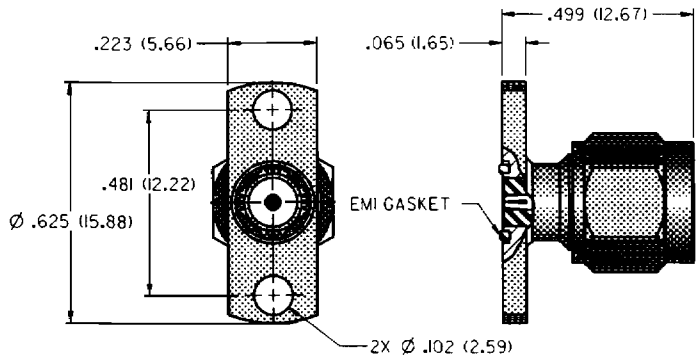

ACCEPTS PIN SIZE	FREQUENCY RANGE	PRODUCT SERIES	GOLD PLATED	NICKEL PLATED
.012	0-26.5 GHz	Brass	142-1801-601	142-1801-606
.015	0-26.5 GHz	Brass	142-1801-611	142-1801-616
.018	0-26.5 GHz	Brass	142-1801-621	142-1801-626

2-Hole Flange Mount Plug Receptacle Without EMI Gasket

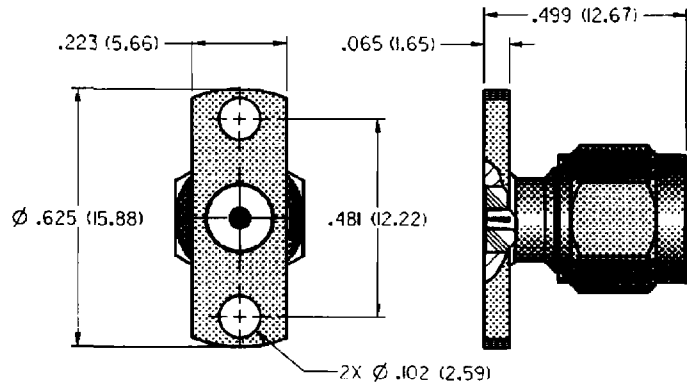

ACCEPTS PIN SIZE	FREQUENCY RANGE	PRODUCT SERIES	GOLD PLATED	NICKEL PLATED
.020	0-26.5 GHz	Brass	142-1801-631	142-1801-636
.036	0-26.5 GHz	Brass	142-1801-641	142-1801-646

SMA Connectors

Field Replaceable

JOHNSON
Components

Inches (millimeters)
customer drawings available upon request

4-Hole Flange Mount Plug Receptacle With EMI Gasket

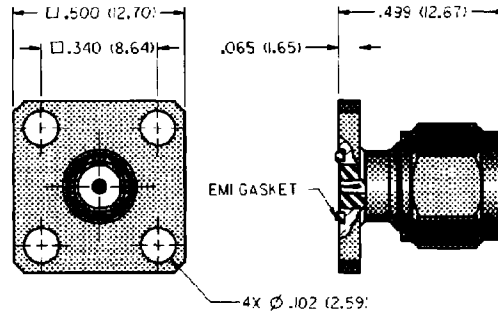
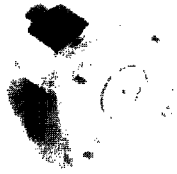

ACCEPTS PIN SIZE	FREQUENCY RANGE	PRODUCT SERIES	GOLD PLATED	NICKEL PLATED
.012	0-26.5 GHz	Brass	142-1801-501	142-1801-506
.015	0-26.5 GHz	Brass	142-1801-511	142-1801-516
.018	0-26.5 GHz	Brass	142-1801-521	142-1801-526

4-Hole Flange Mount Plug Receptacle Without EMI Gasket

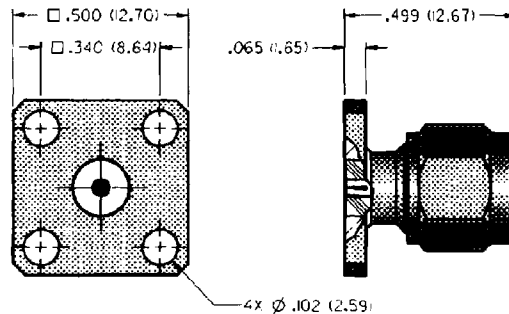

ACCEPTS PIN SIZE	FREQUENCY RANGE	PRODUCT SERIES	GOLD PLATED	NICKEL PLATED
.020	0-26.5 GHz	Brass	142-1801-531	142-1801-536
.036	0-26.5 GHz	Brass	142-1801-541	142-1801-546

4-Hole Flange Mount Plug Receptacle With EMI Gasket

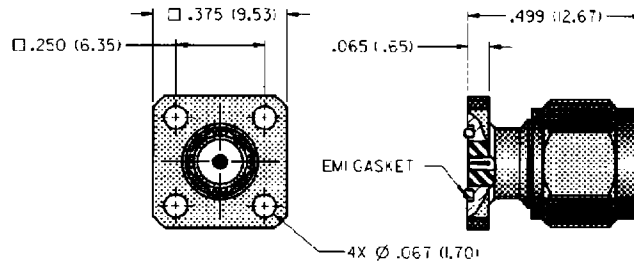

ACCEPTS PIN SIZE	FREQUENCY RANGE	PRODUCT SERIES	GOLD PLATED	NICKEL PLATED
.012	0-26.5 GHz	Brass	142-1801-551	142-1801-556
.015	0-26.5 GHz	Brass	142-1801-561	142-1801-566
.018	0-26.5 GHz	Brass	142-1801-571	142-1801-576

4-Hole Flange Mount Plug Receptacle Without EMI Gasket

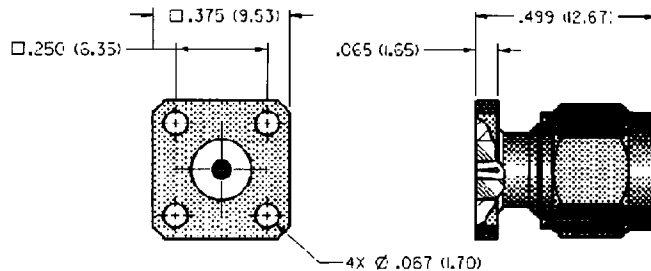

ACCEPTS PIN SIZE	FREQUENCY RANGE	PRODUCT SERIES	GOLD PLATED	NICKEL PLATED
.020	0-26.5 GHz	Brass	142-1801-581	142-1801-586
.036	0-26.5 GHz	Brass	142-1801-591	142-1801-596

SMA Connectors

Field Replaceable

JOHNSON
Components

Inches (millimeters);
customer drawings available upon request

Hermetic Seal Feed-through

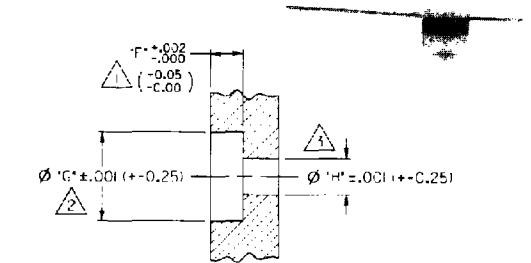
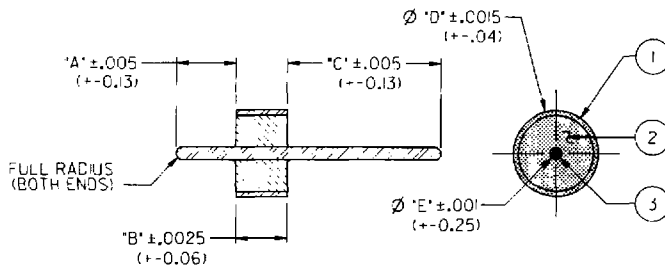

PART NUMBER	ITEM 1 OUTER RING	ITEM 2 INSULATOR	ITEM 3 PIN	"A"	"B"	"C"	"D"	"E"
142-1000-001	Kovar Gold pl .00005 min over Nickel pl .000005 min.	Glass Corning 7052 or equivalent	Kovar Gold pl.00005 min over Nickel p.000005 min	.070 (1.78)	.0625 (1.59)	.180 (4.57)	.0985 (2.50)	.012 (0.30)
142-1000-002	Kovar Gold pl .00005 min over Nickel pl .000005 min.	Glass Corning 7070 or equivalent	Kovar Gold pl.00005 min over Nickel p.000005 min	.072 (1.83)	.0625 (1.59)	.180 (4.57)	.0985 (2.50)	.015 (0.38)
142-1000-003	Kovar Gold pl .00005 min over Nickel pl .000005 min.	Glass Corning 7070 or equivalent	Kovar Gold pl.00005 min over Nickel p.000005 min	.072 (1.83)	.0600 (1.52)	.180 (4.57)	.1100 (2.79)	.018 (0.46)
142-1000-004	Kovar Gold pl .00005 min over Nickel pl .000005 min.	Glass Corning 7052 or equivalent	Kovar Gold pl.00005 min over Nickel p.000005 min	.070 (1.78)	.0600 (1.52)	.203 (5.16)	.1580 (4.01)	.020 (0.51)

Mounting Hole Dimensions

PART NUMBER	PIN DIAMETER	"F"	"G"	AIR	TEFLON
				"H"	"H"
142-1000-001	.012 (0.30)	.063 (1.60)	.102 (2.59)	.028 (0.71)	.039 (0.99)
142-1000-002	.015 (0.38)	.063 (1.60)	.102 (2.59)	.035 (0.89)	.049 (1.24)
142-1000-003	.018 (0.46)	.060 (1.52)	.114 (2.90)	.042 (1.07)	.059 (1.50)
142-1000-004	.020 (0.51)	.060 (1.52)	.162 (4.11)	.046 (1.17)	.065 (1.65)



Notes:

The hermetic seal should be mounted as flush as possible with the housing. Excessive recession will create a high impedance air gap which degrades electrical performance.



The use of an additional counterbore to accommodate a solder ring for seal mounting is not recommended. A slight chamfer may be used if care is taken to completely fill the area with solder - **avoid air gaps**.



Dimensions shown are given to achieve 50 Ohms with either air or a teflon insulator. A teflon insulator may be helpful in supporting small pin diameters.

Electrical:

Impedance: 50 Ohms
Frequency Range: DC to 26.5 GHz
VSWR: Dependent upon application
Working Voltage: 250 Vrms max at sea level
Dielectric Withstanding Voltage: 500 Vrms min at sea level
Insulation Resistance: 5000 Megohm min
Insertion Loss: .015F dB max (F in GHz)

Environmental:

Hermeticity: 1×10^{-8} cc/sec at one atmosphere
Solderability: MIL-STD-202, Method 209
Operating Temperature: -55° C to 165° C

Jack - Jack

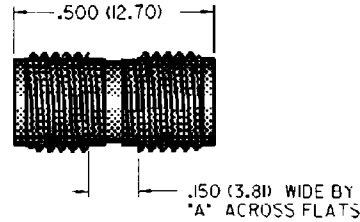

VSWR & FREQ. RANGE	PRODUCT SERIES	GOLD PLATED	NICKEL PLATED	PASSIVATED	DIMENSION "A"
1.05 + .005 f (GHz) 0-18 GHz	Brass	142-0901-801	142-0901-806		.197 (5.00)
1.05 + .005 f (GHz) 0-26.5 GHz	Stainless Steel*	141-0901-801		141-0901-802	.218 (5.54)

* Center contact epoxy staked.

Jack - Bulkhead Jack

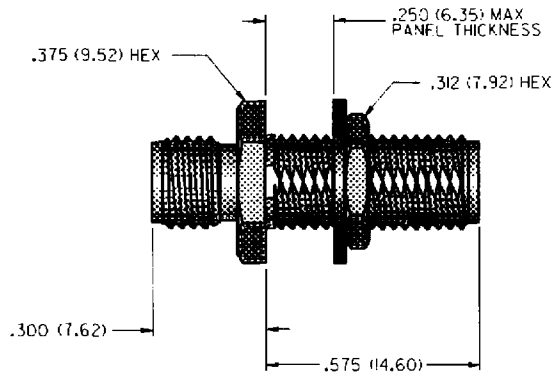

VSWR & FREQ. RANGE	PRODUCT SERIES	GOLD PLATED	NICKEL PLATED	PASSIVATED
1.05 + .01 f (GHz) 0-18 GHz	Brass	142-0901-401	142-0901-406	
1.05 + .005 f (GHz) 0-26.5 GHz	Stainless Steel*	141-0901-401		141-0901-402

* Center contact epoxy staked.

Mounting Hole layout Figure 1 page 121.

SMA Connectors

In-Series Adapters

JOHNSON
Components

Inches (millimeters)
customer drawings available upon request

Plug - Plug

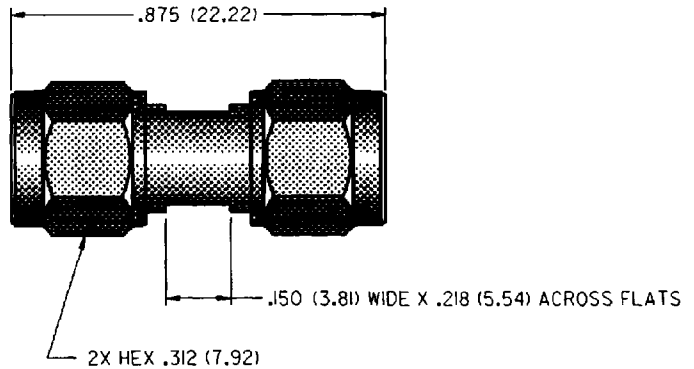

VSWR & FREQ. RANGE	PRODUCT SERIES	GOLD PLATED	NICKEL PLATED	PASSIVATED
1.05 + .01 f (GHz) 0-18 GHz	Brass	142-0901-811	142-0901-816	
1.05 + .005 f (GHz) 0-26.5 GHz	Stainless Steel*	141-0901-811		141-0901-812

*Center contact epoxy staked.

Plug - Jack

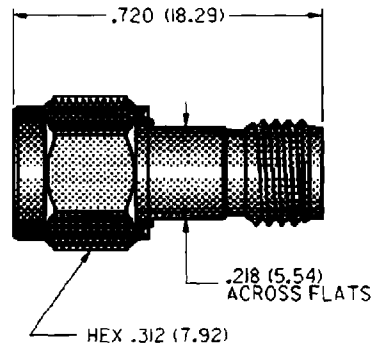

VSWR & FREQ. RANGE	PRODUCT SERIES	GOLD PLATED	NICKEL PLATED	PASSIVATED
1.05 + .005 f (GHz) 0-18 GHz	Brass	142-0901-821	142-0901-826	
1.05 + .005 f (GHz) 0-26.5 GHz	Stainless Steel*	141-0901-821		141-0901-822

*Center contact epoxy staked.