

Product Preview

Y-C Picture-in-Picture (PIP) Controller

The MC44462 Y-C PIP controller is a low cost member of a family of high performance PIP controllers and video signal processors for television. It is a follow-up to the MC44461 PIP and has a modified input selection to allow higher performance in TV systems which have S-Video inputs on the back panel. The S-Video input is separate luma (luminance) and chroma components. It is NTSC compatible and contains all the analog signal processing, control logic and memory necessary to provide for the overlay of a small picture from a second non synchronized source onto the main picture of a television. All control and setup of the MC44462 is via a standard two pin I²C bus interface. The device is fabricated using BICMOS technology. It is available in a 56-pin shrink dip (SDIP) package.

The main features of the MC44462 are:

- Switchable PIP Composite Video Signals – Video 1 and Video 2
- S-Video Output Allows High Performance in TV
- Two PIP Sizes; 1/16 and 1/9 Screen Area
- Freeze Field Feature
- Variable PIP Position in 64-X by 64-Y Steps
- PIP Border with Programmable Color
- Programmable PIP Tint and Saturation Control
- Automatic Main to PIP Contrast Balance
- Vertical Filter
- Integrated 64 k Bit DRAM Memory Resulting in Minimal RFI
- Minimal RFI Allows Simple Low Cost Application into TV
- I²C Bus Control – No External Variable Adjustments Needed
- Operates from a Single 5.0 V Supply
- Economical 56-Pin Shrink DIP Package

MC44462

Y-C PICTURE-IN-PICTURE (PIP) CONTROLLER

SEMICONDUCTOR TECHNICAL DATA

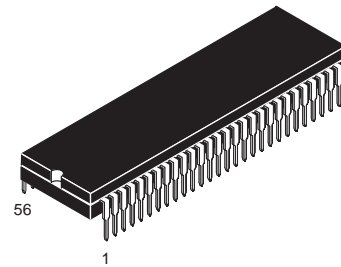

B SUFFIX
PLASTIC PACKAGE
CASE 859
(SDIP)

ORDERING INFORMATION

| Device | Operating Temperature Range | Package |
|----------|---------------------------------|---------|
| MC44462B | T _J = -65° to +150°C | SDIP |

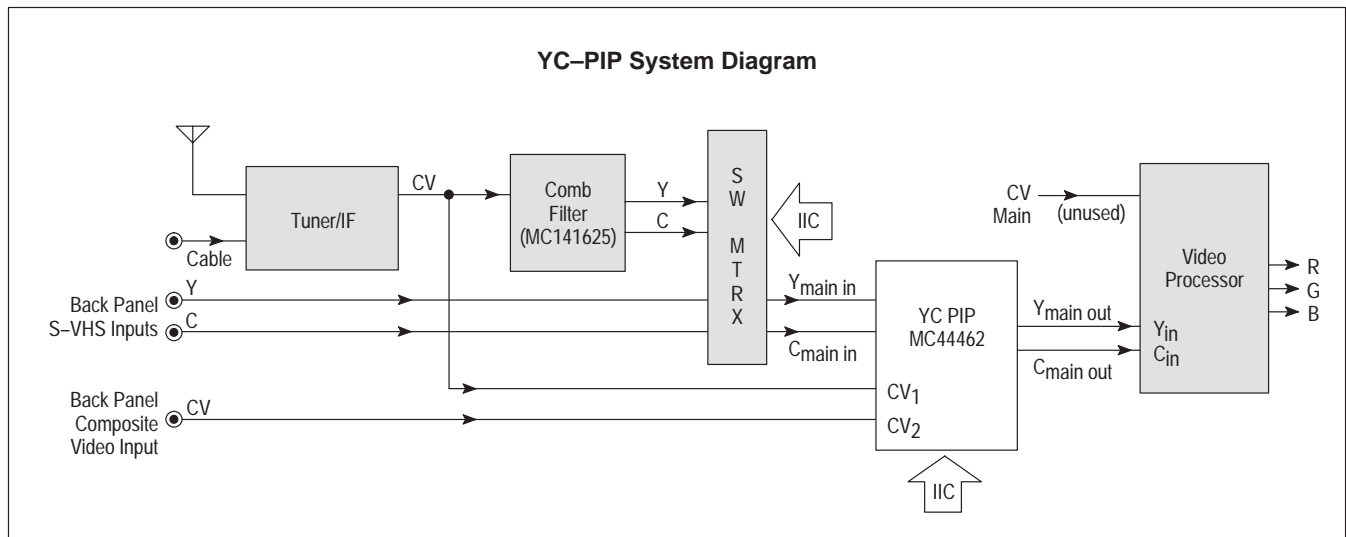

MC44462

MAXIMUM RATINGS

| Rating | Symbol | Value | Unit |
|--|--------------------------|-------------------------|-----------|
| Power Supply Voltage | V_{DD} | -0.5 to +6.0 | V |
| Power Supply Voltage | V_{CC} | -0.5 to +6.0 | V |
| Input Voltage Range | V_{IR} | -0.5, $V_{DD} + 0.5$ | V |
| Output Current | I_O | 160 | mA |
| Power Dissipation Maximum Power Dissipation @ 70°C Thermal Resistance, Junction-to-Air | P_D $R_{\theta JA}$ | 1.3 59 | W °C/W |
| Junction Temperature (Storage and Operating) | T_J | -65 to +150 | °C |

NOTE: ESD data available upon request.

ELECTRICAL CHARACTERISTICS ($V_{CC} = V_{DD} = 5.0$ V, $T_A = 25^\circ\text{C}$, unless otherwise noted.)

| Characteristic | Symbol | Min | Typ | Max | Unit |
|----------------|--------|-----|-----|-----|------|
|----------------|--------|-----|-----|-----|------|

POWER SUPPLY

| | | | | | |
|--------------------------------------|--------------------|---|-----|-----|----|
| Total Supply (Pins 8, 15, 43 and 50) | Total I_{Supply} | - | 100 | 160 | mA |
|--------------------------------------|--------------------|---|-----|-----|----|

VIDEO

| | | | | | |
|--|--------|---|------|---|-----------------|
| Composite Video Input (Pin 34 or 36) | CV_i | - | 1.0 | - | V _{pp} |
| Luma Output (Pin 49, Unterminated) | - | - | 2.0 | - | V _{pp} |
| Video Output DC Level (Sync Tip) | - | - | 1.0 | - | V _{dc} |
| Video Gain | - | - | 6.0 | - | dB |
| Video Frequency Response (Main Video to -1.0 dB) | - | - | 10 | - | MHz |
| Color Bar Accuracy | - | - | ±4.0 | - | deg |
| Video Crosstalk (@ 75% Color Bars) | - | - | - | - | dB |
| Main to PIP | - | - | 55 | - | |
| PIP to Main | - | - | 55 | - | |
| Output Impedance | - | - | 5.0 | - | Ω |

HORIZONTAL TIMEBASE

| | | | | | |
|--|---|---|-------|---|----|
| Free Run HPLL Frequency (Pin 16) | - | - | 15734 | - | Hz |
| HPLL Pull-In Range | - | - | ±400 | - | Hz |
| HPLL Jitter | - | - | ±4.0 | - | ns |
| Burst Gate Timing (from Trailing Edge Hsync, Pin 24) | - | - | 1.0 | - | μs |
| Burst Gate Width | - | - | 4.0 | - | μs |

VERTICAL TIMEBASE

| | | | | | |
|--------------------------------|---|---|-----------|---|---------|
| Vertical Countdown Window | - | - | 232 – 296 | - | H lines |
| Vertical Sync Integration Time | - | - | 31 | - | μs |

ANALOG TO DIGITAL CONVERTER

| | | | | | |
|---|---|---|-------|---|------|
| Resolution | - | - | 6 | - | Bits |
| Integral Non-Linearity | - | - | ±1 | - | LSB |
| Differential Non-Linearity | - | - | +2/-1 | - | LSB |
| ADC – Y Frequency Response @ -5.0 dB | - | - | 1.0 | - | MHz |
| ADC – U, V Frequency Response @ -5.0 dB | - | - | 200 | - | kHz |
| Sample Clock Frequency ($4/3 F_{SC}$) | - | - | 4.773 | - | MHz |

MC44462

ELECTRICAL CHARACTERISTICS (continued) ($V_{CC} = V_{DD} = 5.0\text{ V}$, $T_A = 25^\circ\text{C}$, unless otherwise noted.)

| Characteristic | Symbol | Min | Typ | Max | Unit |
|--|--------|-----|-----------|-----|------|
| DIGITAL TO ANALOG CONVERTER | | | | | |
| Resolution | – | – | – | 6 | Bits |
| Integral Non-Linearity | – | – | ± 1 | – | LSB |
| Differential Non-Linearity | – | – | $+2/-1$ | – | LSB |
| Tint DAC Control Range (in 64 Steps) | – | – | ± 10 | – | Deg |
| Saturation DAC Control Range (in 64 steps) | – | – | ± 6.0 | – | dB |

NTSC DECODER

| | | | | | |
|--|---|---|-----------|---|----|
| Color Kill Threshold | – | – | $-24/-16$ | – | dB |
| Threshold Hysteresis | – | – | ± 1.0 | – | dB |
| ACC (Chroma Amplitude Change, +3.0 dB to –12 dB) | – | – | ± 0.5 | – | dB |

PIP CHARACTERISTICS

| | | | | | |
|---|---|---|--------|---|-------|
| PIP Size | – | – | – | – | – |
| 1/9 Screen Horizontal | – | – | 114 | – | pels |
| 1/9 Screen Vertical | – | – | 71 | – | lines |
| 1/16 Screen Horizontal | – | – | 84 | – | pels |
| 1/16 Screen Vertical | – | – | 53 | – | lines |
| Border Size Horizontal | – | – | 3 | – | pels |
| Border Size Vertical | – | – | 2 | – | lines |
| Output PEL Clock ($4 F_{SC}$) | – | – | 14.318 | – | MHz |
| Position Control Range Horizontal (% of Main Picture), 64 Steps | – | – | 100 | – | % |
| Position Control Range Vertical (% of Main Picture), 64 Steps | – | – | 100 | – | % |

Figure 1. Representative Block Diagram

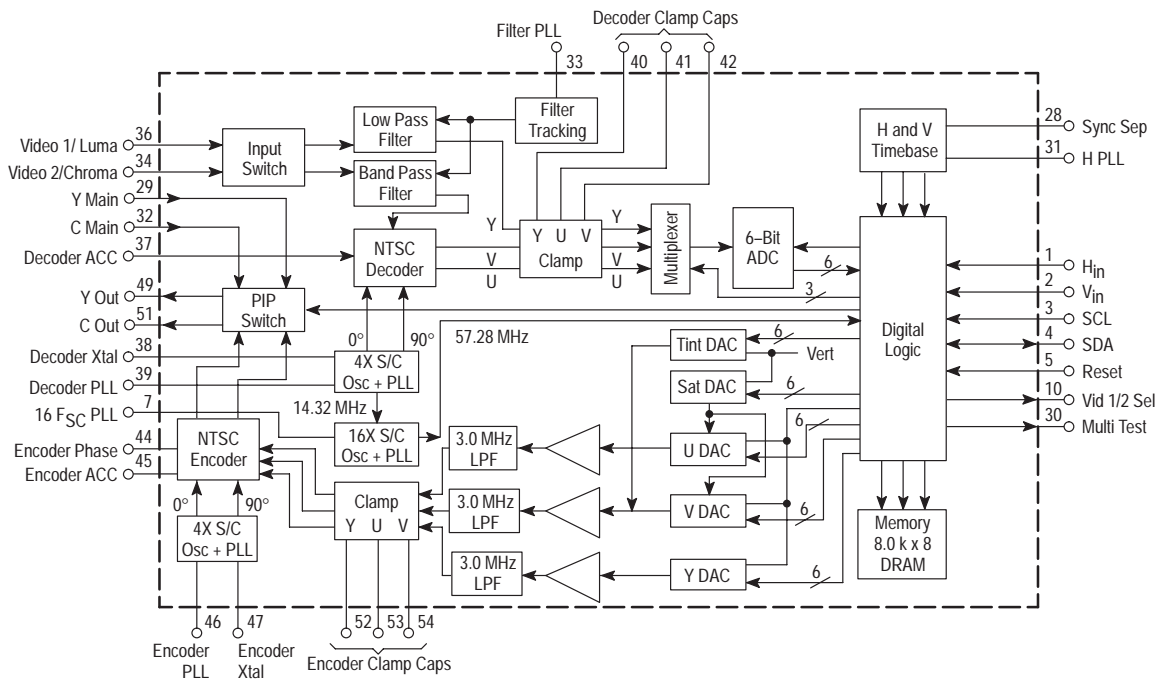

This device contains approximately 500,000 active transistors.

I²C REGISTER DESCRIPTIONS

Base write address = 24h

Base read address = 25h

Read Register

There are two active bits in the single read byte available from the MC44462 as follows:

Write Vertical Indicator (WVIO) – D7

When 0 indicates that the write operation specified by the last I²C command has been completed.

PIP Sync Detect Bit (PSD0) – D1

When 0 indicates that the PIP video H pulses are present and the horizontal timebase oscillator is within acceptable limits.

Write Registers**Read Start Position/Write Start Position Registers**

Sub-address = 00h

Write Raster Position Start Bits (WPS0–2) – D0–D2

Establishes the horizontal beginning of the PIP and its black level measurement gate. This beginning may be varied by approximately 3.0 μ s. The position of this pulse may be observed through the Multi Test Pin 30 (See Test Mode Register Sub-address 03h).

Read Raster Position Bits (RPS0–3) – D4–D7

Establishes the clamp gate position for the black level reference for the main picture. This position may be varied by approximately 5.0 μ s. The position of this pulse may be observed through the Multi Test Pin 30 (See Test Mode Register Sub-address 03h).

Pip Switch Delay/Vertical Filter Register

Sub-address = 01h

PIP Switch Delay Bits (PSD0–3) – D0–D3

Delays the start of PIP on time relative to the PIP picture. These bits are used to center the PIP border and PIP picture in the horizontal direction.

Vertical Filter Bit (VFON) – D4

When the filter is activated (VFON = 1) a three line weighted average is taken to provide the data stored in the field memory.

Border Color Register

Sub-address = 02h

Border Color Bits (BC0–2) – D0–D2

These Bits control the color of the border. Note that when using one of the saturated border colors it is possible to get objectionable dot crawl at the edge of the border in some TVs unless appropriate comb filtering is used in the TV circuitry.

| BC (2:0) | Border Color |
|----------|-------------------|
| 000 | Black |
| 001 | White 70% |
| 010 | No Border (clear) |
| 011 | No Border (clear) |
| 100 | Blue |
| 101 | Green |
| 110 | Red |
| 111 | White |

Test Mode/Main Vertical and Horizontal Polarity Register

Sub-address = 03h

Internal Test Mode Register (ITM0–2) – D0–D2

Sets the Multi Test Pin output to provide one of several internal signals for test and production alignment. Also controls the test memory address counter.

| ITM (2:0) | Multi-Test I/O and Function |
|-----------|-----------------------------|
| 000 | Input – Analog Test mode |
| 001 | Input – Digital Test mode |
| 010 | Output – Sync Detect |
| 011 | Output – PIP Switch |
| 100 | Output – PIP H Detect |
| 101 | Output – PIP V Detect |
| 110 | Output – PIP Clamp |
| 111 | Output – Main Clamp |

Main vertical polarity select bit (MVP0) – D6

Selects polarity of active level of vertical reference input. 0 = positive going, 1 = negative going.

Main horizontal polarity select bit (MHP0) – D7

Selects polarity of active level of horizontal reference input. 0 = positive going, 1 = negative going.

PIP Freeze/PIP Size/Main and PIP Video Source Register

Sub-address = 04h

PIP Freeze Bit (STILO) – D4

When set to one, the most recently received field is continuously displayed until the freeze bit is cleared.

PIP Size Bit (PSI90) – D5

Switches the PIP size between 1/16 main size (when 0) and 1/9 main size (when 1).

Video Type Select Bit (YCPSEL) – D6

Selects which video type will be applied to the PIP input.

PIP Video Source Select Bit (PSEL0) – D7

Selects which composite video input will be applied to the video decoder to provide the PIP video in CV mode.

| PSEL | YCPSEL | Function |
|--------|--------|--|
| 0 | 1 | YC Input to PIP |
| 0 1 | 0 | CV ₁ Input to PIP CV ₂ Input to PIP |

PIP On/PIP Blank Register

Sub-address = 05h

PIP On Bit (PON0) – D0

When on (1) turns the PIP on.

PIP Blanking Bit (PBL0) – D4

When on (1) sets the PIP to black. If the PIP is off, then it will be black if it is turned on. Overrides all other settings of the PIP control.

PIP X Position Register

Sub-address = 06h

X Position Bits (XPS0–5) – D0–D5

Moves the PIP start position from the left to the right edge of the display in 64 steps. There is protection circuitry

MC44462

to prevent the PIP from interfering with the main picture sync pulses.

PIP Y Position Register

Sub-address = 07h

Y Position Bits (YPS0–5) – D0–D5

Moves the PIP start position from the top to the bottom edge of the display in 64 steps. There is protection circuitry to prevent the PIP from interfering with the main picture sync pulses.

PIP Chroma Level Register

Sub-address = 08h

Chroma (C0–5) – D0–D5

The color of the PIP can be adjusted to suit viewer preference by setting the value stored in these bits. A total of 64 steps varies the color from no color to maximum. This control acts in conjunction with the auto phase control.

PIP Tint Level Register

Sub-address = 09h

Tint (T0–5) – D0–D5

An auto phase control compares the main color burst to the internally generated pseudo color burst so that the tints

are matched. In addition to this, the tint of the PIP can be varied $\pm 10^\circ$ in a total of 64 steps by changing the value of these bits to suit viewer preference.

PIP Luma Delay Register

Sub-address = 0Ah

Y Delay (YDL0–2) – D0–D2

Since the Chroma passes through a bandpass filter and the color decoder, it is delayed with respect to the Luma signal. Therefore, to time match the Luma and Chroma these bits are set to a single value determined to be correct in the application.

Pip Fill/Test Register

Sub-address = 0Ch

PIP Fill Bits (PIPFILL0–1) – D0–D1

May be used to fill the PIP with one of three selectable solid colors

Test Register Bits (INTC0 and MACR0) – D6–D7

Used for production test only.

I²C REGISTER TABLE

| Sub-address | Data Bit | | | | | | | |
|-------------|----------|--------|-------|-------|------|------|------|------|
| | D7 | D6 | D5 | D4 | D3 | D2 | D1 | D0 |
| 00 | RPS3 | RPS2 | RPS1 | RPS0 | – | WPS2 | WPS1 | WPS0 |
| 01 | – | – | – | VFON | PSD3 | PSD2 | PSD1 | PSD0 |
| 02 | – | – | – | – | – | BC2 | BC1 | BC0 |
| 03 | MHP0 | MVP0 | – | – | – | ITM2 | ITM1 | ITM0 |
| 04 | PSEL0 | YCPSEL | PSI90 | STIL0 | – | – | – | – |
| 05 | – | – | – | PBL0 | – | – | – | PON0 |
| 06 | – | – | XPS5 | XPS4 | XPS3 | XPS2 | XPS1 | XPS0 |
| 07 | – | – | YPS5 | YPS4 | YPS3 | YPS2 | YPS1 | YPS0 |
| 08 | – | – | C5 | C4 | C3 | C2 | C1 | C0 |
| 09 | – | – | T5 | T4 | T3 | T2 | T1 | T0 |
| 0A | – | – | – | – | – | YDL2 | YDL1 | YDL0 |
| 0B | – | – | – | – | – | – | – | – |
| 0C | – | – | – | – | – | – | – | – |

Tape and Reel Options

In Brief . . .

Motorola offers the convenience of Tape and Reel packaging for our growing family of standard integrated circuit products. Reels are available to support the requirements of both first and second generation pick-and-place equipment. The packaging fully conforms to the latest EIA-481A specification. The antistatic embossed tape provides a secure cavity, sealed with a peel-back cover tape.

| | Page |
|---|-------------|
| Tape and Reel Configurations | 12-2 |
| Tape and Reel Information Table | 12-4 |
| Analog MPQ Table | 12-5 |

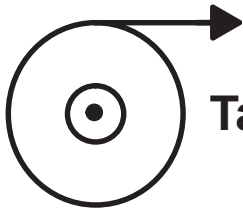

Tape and Reel Configurations

Mechanical Polarization

SOIC and Micro-8 DEVICES

Typical

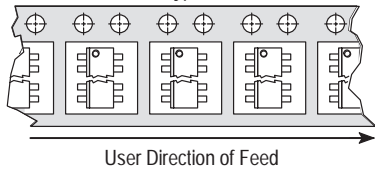

PLCC DEVICES

Typical

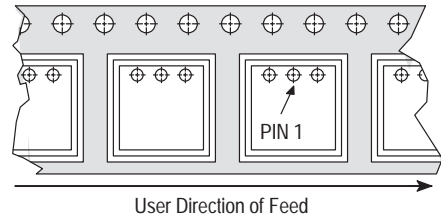

DPAK and D²PAK DEVICES

Typical

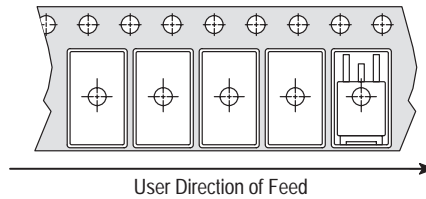

SOT-23 (5 Pin) DEVICES

Typical

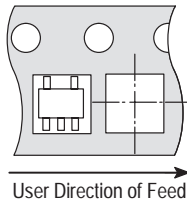

SOT-89 (3 Pin) DEVICES

Typical

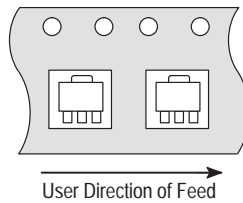

SOT-89 (5 Pin) DEVICES

Typical

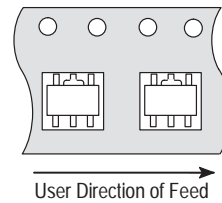

Tape and Reel Configurations (continued)

TO-92 Reel Styles

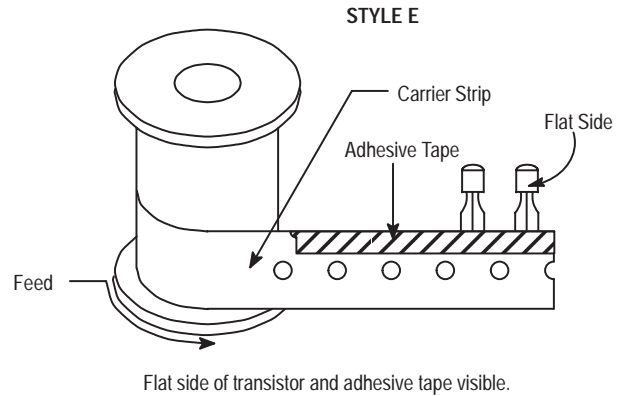
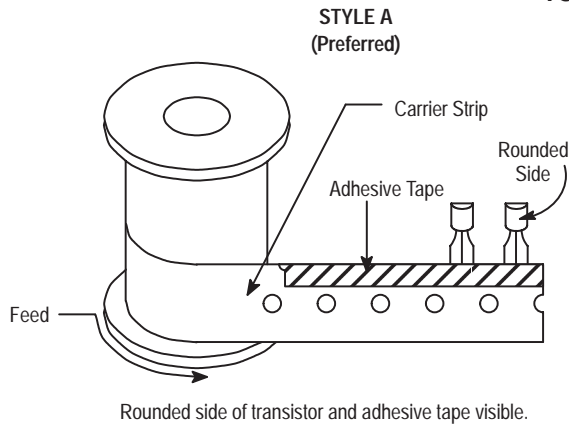

TO-92 Ammo Pack Styles

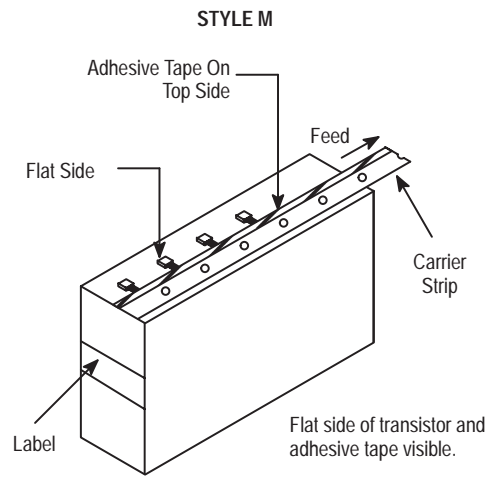
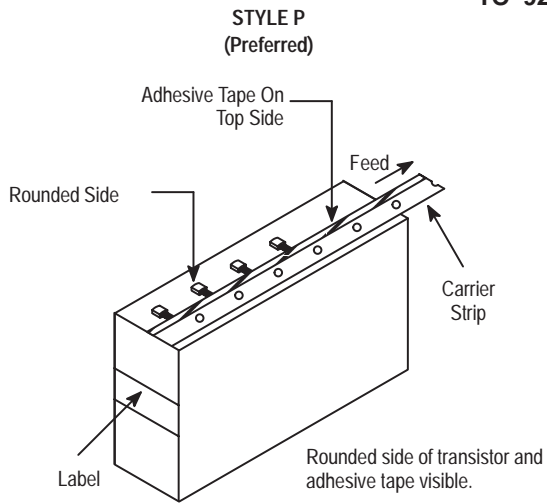

Style P ammo pack is equivalent to Styles A and B of reel pack dependent on feed orientation from box.

Style M ammo pack is equivalent to Style E of reel pack dependent on feed orientation from box.

TO-92 EIA Radial Tape in Fan Fold Box or On Reel

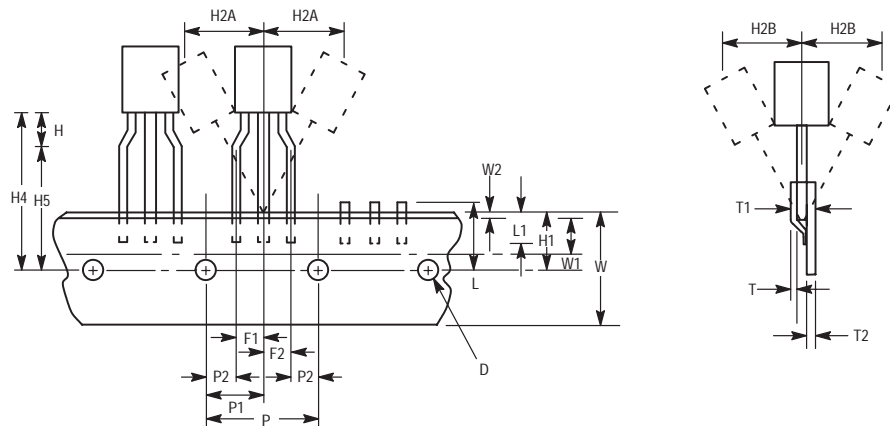

Tape and Reel Information Table

| Package | Tape Width (mm) | Devices ⁽¹⁾ per Reel | Reel Size (inch) | Device Suffix |
|---------------------------------|-----------------|---------------------------------|------------------|---------------------------------------|
| SO-8, SOP-8 | 12 | 2,500 | 13 | R2 |
| SO-14 | 16 | 2,500 | 13 | R2 |
| SO-16 | 16 | 2,500 | 13 | R2 |
| SO-16L, SO-8+8L WIDE | 16 | 1,000 | 13 | R2 |
| SO-20L WIDE | 24 | 1,000 | 13 | R2 |
| SO-24L WIDE | 24 | 1,000 | 13 | R2 |
| SO-28L WIDE | 24 | 1,000 | 13 | R2 |
| SO-28L WIDE | 32 | 1,000 | 13 | R3 |
| Micro-8 | 12 | 2,500 | 13 | R2 |
| PLCC-20 | 16 | 1,000 | 13 | R2 |
| PLCC-28 | 24 | 500 | 13 | R2 |
| PLCC-44 | 32 | 500 | 13 | R2 |
| PLCC-52 | 32 | 500 | 13 | R2 |
| PLCC-68 | 44 | 250 | 13 | R2 |
| PLCC-84 | 44 | 250 | 13 | R2 |
| TO-226AA (TO-92) ⁽²⁾ | 18 | 2,000 | 13 | RA, RE, RP, or RM (Ammo Pack) only |
| DPAK | 16 | 2,500 | 13 | RK |
| D ² PAK | 24 | 800 | 13 | R4 |
| SOT-23 (5 Pin) | 8 | 3,000 | 7 | TR |
| SOT-89 (3/5 Pin) | 12 | 1,000 | 7 | T1 |

⁽¹⁾ Minimum order quantity is 1 reel. Distributors/OEM customers may break lots or reels at their option, however broken reels may not be returned.

⁽²⁾ Integrated circuits in TO-226AA packages are available in Styes A and E only, with optional "Ammo Pack" (Suffix RP or RM). The RA and RP configurations are preferred. For ordering information please contact your local Motorola Semiconductor Sales Office.

Analog MPQ Table

Tape/Reel and Ammo Pack

| Package Type | Package Code | MPQ |
|-----------------------|--------------|----------------|
| PLCC | | |
| Case 775 | 0802 | 1000/reel |
| Case 776 | 0804 | 500/reel |
| Case 777 | 0801 | 500/reel |
| SOIC | | |
| Case 751 | 0095 | 2500/reel |
| Case 751A | 0096 | 2500/reel |
| Case 751B | 0097 | 2500/reel |
| Case 751G | 2003 | 1000/reel |
| Case 751D | 2005 | 1000/reel |
| Case 751E | 2008 | 1000/reel |
| Case 751F | 2009 | 1000/reel |
| Micro-8 | | |
| Case 846A | - | 2500/reel |
| TO-92 | | |
| Case 29 | 0031 | 2000/reel |
| Case 29 | 0031 | 2000/Ammo Pack |
| DPAK | | |
| Case 369A | - | 2500/reel |
| D2PAK | | |
| Case 936 | - | 800/reel |
| SOT-23 (5 Pin) | | |
| Case 1212 | - | 3000/reel |
| SOT-89 (3 Pin) | | |
| Case 1213 | - | 1000/reel |
| SOT-89 (5 Pin) | | |
| Case 1214 | - | 1000/reel |

Packaging Information

In Brief . . .

The packaging availability for each device type is indicated on the individual data sheets and the Selector Guide. All of the outline dimensions for the packages are given in this section.

The maximum power consumption an integrated circuit can tolerate at a given operating ambient temperature can be found from the equation:

$$P_{D(TA)} = \frac{T_{J(max)} - T_A}{R_{\theta JA(Typ)}}$$

where:

$P_{D(TA)}$ = *Power Dissipation allowable at a given operating ambient temperature. This must be greater than the sum of the products of the supply voltages and supply currents at the worst case operating condition.*

$T_{J(max)}$ = *Maximum operating Junction Temperature as listed in the Maximum Ratings Section. See individual data sheets for $T_{J(max)}$ information.*

T_A = *Maximum desired operating Ambient Temperature*

$R_{\theta JA(Typ)}$ = *Typical Thermal Resistance Junction-to-Ambient*

Case Outline Dimensions

LP, P, Z SUFFIX
CASE 29-04
 Plastic Package
 (TO-226AA/TO-92)
 ISSUE AD

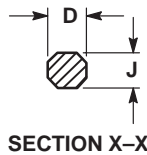
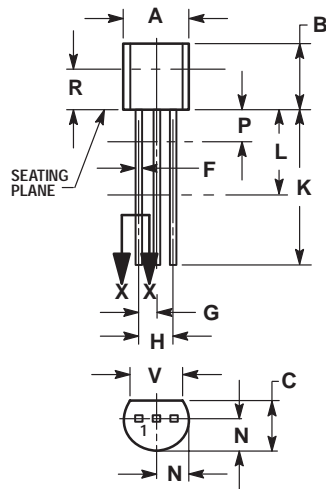
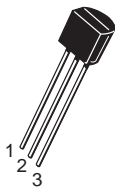

NOTES:

1. DIMENSIONING AND TOLERANCING PER ANSI Y14.5M, 1982.
2. CONTROLLING DIMENSION: INCH.
3. CONTOUR OF PACKAGE BEYOND DIMENSION R IS UNCONTROLLED.
4. DIMENSION F APPLIES BETWEEN P AND L. DIMENSION D AND J APPLY BETWEEN L AND K MINIMUM. LEAD DIMENSION IS UNCONTROLLED IN P AND BEYOND DIMENSION K MINIMUM.

| DIM | INCHES | | MILLIMETERS | |
|-----|--------|-------|-------------|------|
| | MIN | MAX | MIN | MAX |
| A | 0.175 | 0.205 | 4.45 | 5.20 |
| B | 0.170 | 0.210 | 4.32 | 5.33 |
| C | 0.125 | 0.165 | 3.18 | 4.19 |
| D | 0.016 | 0.022 | 0.41 | 0.55 |
| F | 0.016 | 0.019 | 0.41 | 0.48 |
| G | 0.045 | 0.055 | 1.15 | 1.39 |
| H | 0.095 | 0.105 | 2.42 | 2.66 |
| J | 0.015 | 0.020 | 0.39 | 0.50 |
| K | 0.500 | --- | 12.70 | --- |
| L | 0.250 | --- | 6.35 | --- |
| N | 0.080 | 0.105 | 2.04 | 2.66 |
| P | --- | 0.100 | --- | 2.54 |
| R | 0.115 | --- | 2.93 | --- |
| V | 0.135 | --- | 3.43 | --- |

KC, T SUFFIX
CASE 221A-06
 Plastic Package
 ISSUE Y

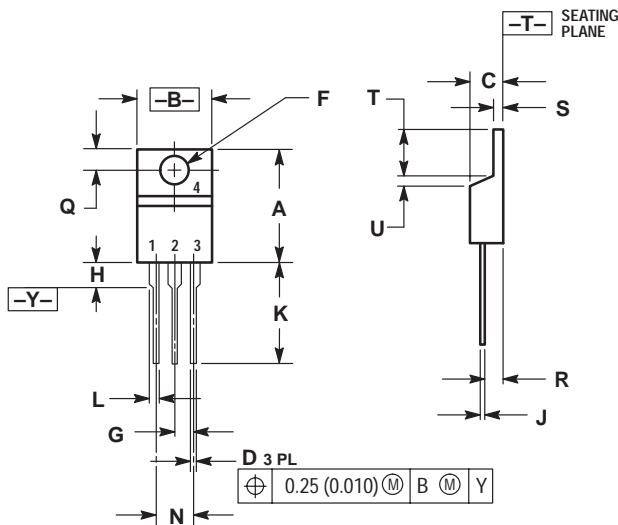
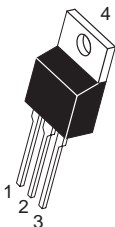

NOTES:

1. DIMENSIONING AND TOLERANCING PER ANSI Y14.5M, 1982.
2. CONTROLLING DIMENSION: INCH.

| DIM | INCHES | | MILLIMETERS | |
|-----|-----------|-------|-------------|-------|
| | MIN | MAX | MIN | MAX |
| A | 0.560 | 0.625 | 14.23 | 15.87 |
| B | 0.380 | 0.420 | 9.66 | 10.66 |
| C | 0.140 | 0.190 | 3.56 | 4.82 |
| D | 0.020 | 0.045 | 0.51 | 1.14 |
| F | 0.139 | 0.155 | 3.53 | 3.93 |
| G | 0.100 BSC | --- | 2.54 BSC | --- |
| H | --- | 0.280 | --- | 7.11 |
| J | 0.012 | 0.045 | 0.31 | 1.14 |
| K | 0.500 | 0.580 | 12.70 | 14.73 |
| L | 0.045 | 0.070 | 1.15 | 1.77 |
| N | 0.200 BSC | --- | 5.08 BSC | --- |
| Q | 0.100 | 0.135 | 2.54 | 3.42 |
| R | 0.080 | 0.115 | 2.04 | 2.92 |
| S | 0.020 | 0.055 | 0.51 | 1.39 |
| T | 0.235 | 0.255 | 5.97 | 6.47 |
| U | 0.000 | 0.050 | 0.00 | 1.27 |

TH SUFFIX
CASE 314A-03
 Plastic Package
 ISSUE D

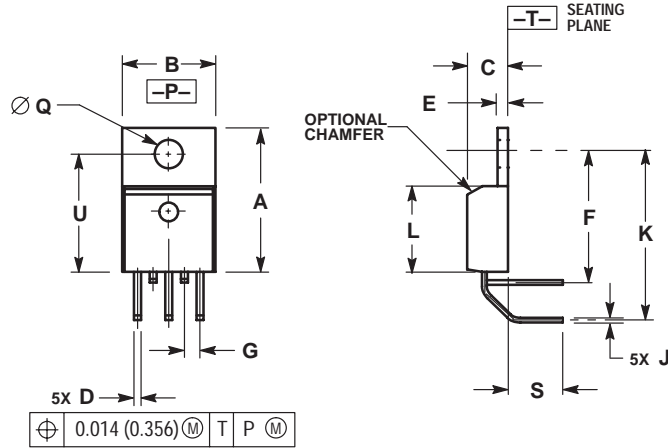
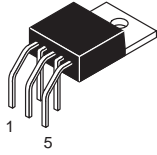

NOTES:

1. DIMENSIONING AND TOLERANCING PER ANSI Y14.5M, 1982.
2. CONTROLLING DIMENSION: INCH.
3. DIMENSION D DOES NOT INCLUDE INTERCONNECT BAR (DAMBAR) PROTRUSION. DIMENSION D INCLUDING PROTRUSION SHALL NOT EXCEED 0.043 (1.092) MAXIMUM.

| DIM | INCHES | | MILLIMETERS | |
|-----|-----------|-------|-------------|--------|
| | MIN | MAX | MIN | MAX |
| A | 0.572 | 0.613 | 14.529 | 15.570 |
| B | 0.390 | 0.415 | 9.906 | 10.541 |
| C | 0.170 | 0.180 | 4.318 | 4.572 |
| D | 0.025 | 0.038 | 0.635 | 0.965 |
| E | 0.048 | 0.055 | 1.219 | 1.397 |
| F | 0.570 | 0.585 | 14.478 | 14.859 |
| G | 0.067 BSC | | 1.702 BSC | |
| J | 0.015 | 0.025 | 0.381 | 0.635 |
| K | 0.730 | 0.745 | 18.542 | 18.923 |
| L | 0.320 | 0.365 | 8.128 | 9.271 |
| Q | 0.140 | 0.153 | 3.556 | 3.886 |
| S | 0.210 | 0.260 | 5.334 | 6.604 |
| U | 0.468 | 0.505 | 11.888 | 12.827 |

T, TV SUFFIX
CASE 314B-05
 Plastic Package
 ISSUE J

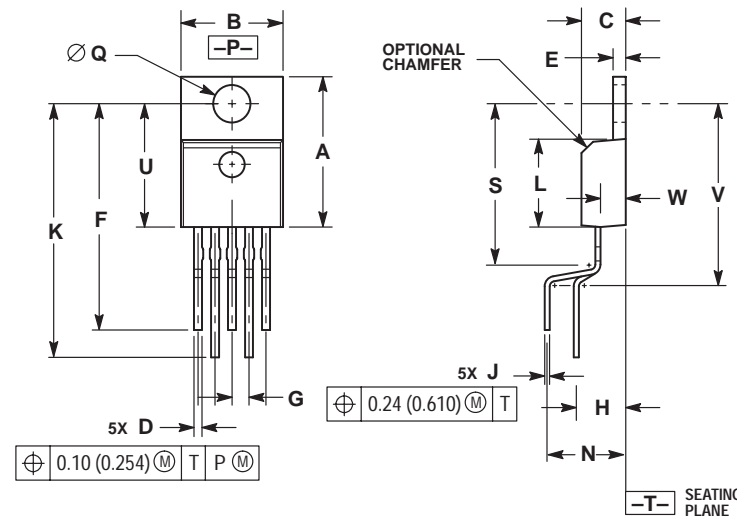
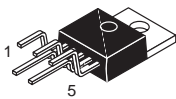

NOTES:

1. DIMENSIONING AND TOLERANCING PER ANSI Y14.5M, 1982.
2. CONTROLLING DIMENSION: INCH.
3. DIMENSION D DOES NOT INCLUDE INTERCONNECT BAR (DAMBAR) PROTRUSION. DIMENSION D INCLUDING PROTRUSION SHALL NOT EXCEED 0.043 (1.092) MAXIMUM.

| DIM | INCHES | | MILLIMETERS | |
|-----|-----------|-------|-------------|--------|
| | MIN | MAX | MIN | MAX |
| A | 0.572 | 0.613 | 14.529 | 15.570 |
| B | 0.390 | 0.415 | 9.906 | 10.541 |
| C | 0.170 | 0.180 | 4.318 | 4.572 |
| D | 0.025 | 0.038 | 0.635 | 0.965 |
| E | 0.048 | 0.055 | 1.219 | 1.397 |
| F | 0.850 | 0.935 | 21.590 | 23.749 |
| G | 0.067 BSC | | 1.702 BSC | |
| H | 0.166 BSC | | 4.216 BSC | |
| J | 0.015 | 0.025 | 0.381 | 0.635 |
| K | 0.900 | 1.100 | 22.860 | 27.940 |
| L | 0.320 | 0.365 | 8.128 | 9.271 |
| N | 0.320 BSC | | 8.128 BSC | |
| Q | 0.140 | 0.153 | 3.556 | 3.886 |
| S | --- | 0.620 | --- | 15.748 |
| U | 0.468 | 0.505 | 11.888 | 12.827 |
| V | --- | 0.735 | --- | 18.669 |
| W | 0.090 | 0.110 | 2.286 | 2.794 |

T SUFFIX
CASE 314C-01
 Plastic Package
 ISSUE A

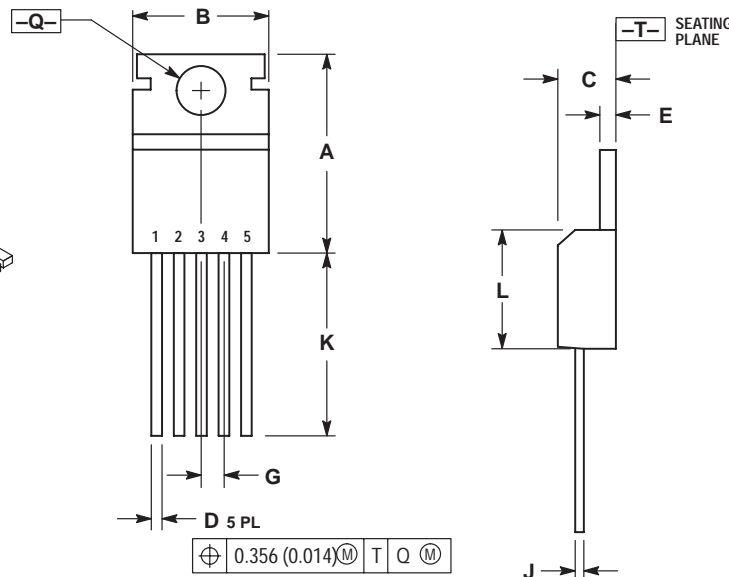
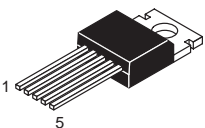

NOTES:

1. DIMENSIONING AND TOLERANCING PER ANSI Y14.5M, 1982.
2. CONTROLLING DIMENSION: INCH.
3. DIMENSION D DOES NOT INCLUDE INTERCONNECT BAR (DAMBAR) PROTRUSION. DIMENSION D INCLUDING PROTRUSION SHALL NOT EXCEED 10.92 (0.043) MAXIMUM.

| DIM | INCHES | | MILLIMETERS | |
|-----|-----------|-------|-------------|-------|
| | MIN | MAX | MIN | MAX |
| A | 0.610 | 0.625 | 15.59 | 15.88 |
| B | 0.380 | 0.420 | 9.65 | 10.67 |
| C | 0.160 | 0.190 | 4.06 | 4.83 |
| D | 0.020 | 0.040 | 0.51 | 1.02 |
| E | 0.035 | 0.055 | 0.89 | 1.40 |
| G | 0.067 BSC | | 1.702 BSC | |
| J | 0.015 | 0.025 | 0.38 | 0.64 |
| K | 0.500 | --- | 12.70 | --- |
| L | 0.355 | 0.370 | 9.02 | 9.40 |
| Q | 0.139 | 0.147 | 3.53 | 3.73 |

T, T1 SUFFIX
CASE 314D-03
 Plastic Package
 ISSUE D

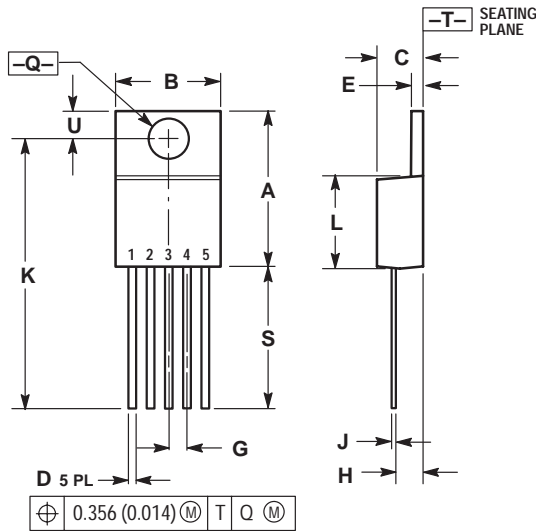
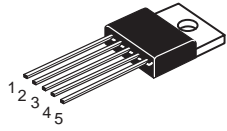

- NOTES:
1. DIMENSIONING AND TOLERANCING PER ANSI Y14.5M, 1982.
 2. CONTROLLING DIMENSION: INCH.
 3. DIMENSION D DOES NOT INCLUDE INTERCONNECT BAR (DAMBAR) PROTRUSION. DIMENSION D INCLUDING PROTRUSION SHALL NOT EXCEED 10.92 (0.043) MAXIMUM.

| DIM | INCHES | | MILLIMETERS | |
|-----|-----------|-------|-------------|--------|
| | MIN | MAX | MIN | MAX |
| A | 0.572 | 0.613 | 14.529 | 15.570 |
| B | 0.390 | 0.415 | 9.906 | 10.541 |
| C | 0.170 | 0.180 | 4.318 | 4.572 |
| D | 0.025 | 0.038 | 0.635 | 0.965 |
| E | 0.048 | 0.055 | 1.219 | 1.397 |
| G | 0.067 BSC | | 1.702 BSC | |
| H | 0.087 | 0.112 | 2.210 | 2.845 |
| J | 0.015 | 0.025 | 0.381 | 0.635 |
| K | 1.020 | 1.065 | 25.908 | 27.051 |
| L | 0.320 | 0.365 | 8.128 | 9.271 |
| Q | 0.140 | 0.153 | 3.556 | 3.886 |
| U | 0.105 | 0.117 | 2.667 | 2.972 |
| S | 0.543 | 0.582 | 13.792 | 14.783 |

DT-1 SUFFIX
CASE 369-07
 Plastic Package (DPAK)
 ISSUE K

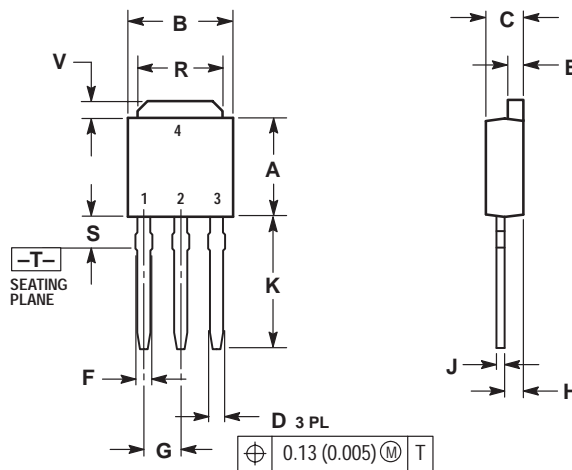
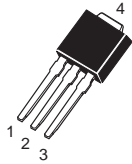

- NOTES:
1. DIMENSIONING AND TOLERANCING PER ANSI Y14.5M, 1982.
 2. CONTROLLING DIMENSION: INCH.

| DIM | INCHES | | MILLIMETERS | |
|-----|-----------|-------|-------------|------|
| | MIN | MAX | MIN | MAX |
| A | 0.235 | 0.250 | 5.97 | 6.35 |
| B | 0.250 | 0.265 | 6.35 | 6.73 |
| C | 0.086 | 0.094 | 2.19 | 2.38 |
| D | 0.027 | 0.035 | 0.69 | 0.88 |
| E | 0.033 | 0.040 | 0.84 | 1.01 |
| F | 0.037 | 0.047 | 0.94 | 1.19 |
| G | 0.090 BSC | | 2.29 BSC | |
| H | 0.034 | 0.040 | 0.87 | 1.01 |
| J | 0.018 | 0.023 | 0.46 | 0.58 |
| K | 0.350 | 0.380 | 8.89 | 9.65 |
| R | 0.175 | 0.215 | 4.45 | 5.46 |
| S | 0.050 | 0.090 | 1.27 | 2.28 |
| V | 0.030 | 0.050 | 0.77 | 1.27 |

DT SUFFIX
CASE 369A-13
 Plastic Package (DPAK)
 ISSUE Y

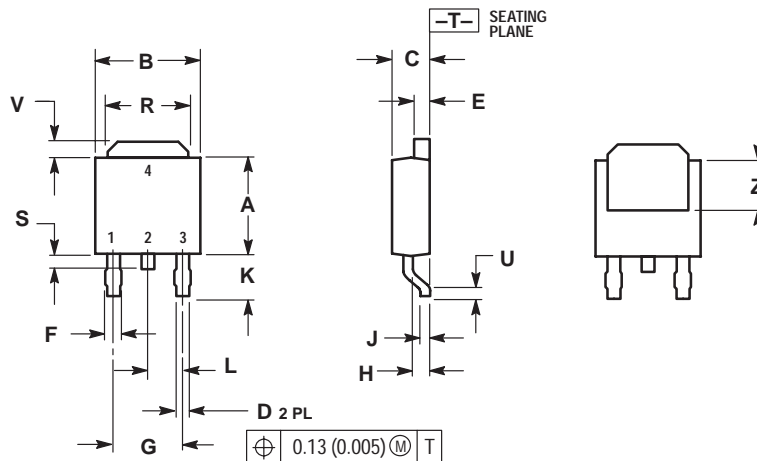
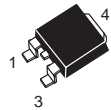

- NOTES:
1. DIMENSIONING AND TOLERANCING PER ANSI Y14.5M, 1982.
 2. CONTROLLING DIMENSION: INCH.

| DIM | INCHES | | MILLIMETERS | |
|-----|-----------|-------|-------------|------|
| | MIN | MAX | MIN | MAX |
| A | 0.235 | 0.250 | 5.97 | 6.35 |
| B | 0.250 | 0.265 | 6.35 | 6.73 |
| C | 0.086 | 0.094 | 2.19 | 2.38 |
| D | 0.027 | 0.035 | 0.69 | 0.88 |
| E | 0.033 | 0.040 | 0.84 | 1.01 |
| F | 0.037 | 0.047 | 0.94 | 1.19 |
| G | 0.180 BSC | | 4.58 BSC | |
| H | 0.034 | 0.040 | 0.87 | 1.01 |
| J | 0.018 | 0.023 | 0.46 | 0.58 |
| K | 0.102 | 0.114 | 2.60 | 2.89 |
| L | 0.090 BSC | | 2.29 BSC | |
| R | 0.175 | 0.215 | 4.45 | 5.46 |
| S | 0.020 | 0.050 | 0.51 | 1.27 |
| U | 0.020 | --- | 0.51 | --- |
| V | 0.030 | 0.050 | 0.77 | 1.27 |
| Z | 0.138 | --- | 3.51 | --- |

DP1, N, P, P1 SUFFIX
CASE 626-05
 Plastic Package
 ISSUE K

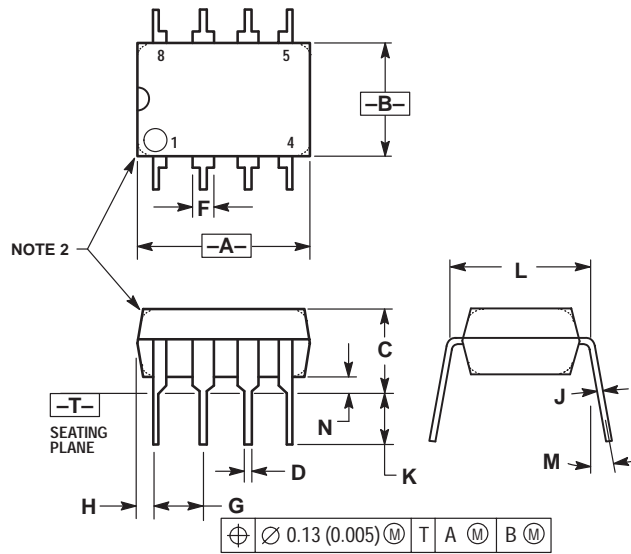
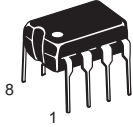

- NOTES:
1. DIMENSION L TO CENTER OF LEAD WHEN FORMED PARALLEL.
 2. PACKAGE CONTOUR OPTIONAL (ROUND OR SQUARE CORNERS).
 3. DIMENSIONING AND TOLERANCING PER ANSI Y14.5M, 1982.

| DIM | MILLIMETERS | | INCHES | |
|-----|-------------|-------|-----------|-------|
| | MIN | MAX | MIN | MAX |
| A | 9.40 | 10.16 | 0.370 | 0.400 |
| B | 6.10 | 6.60 | 0.240 | 0.260 |
| C | 3.94 | 4.45 | 0.155 | 0.175 |
| D | 0.38 | 0.51 | 0.015 | 0.020 |
| F | 1.02 | 1.78 | 0.040 | 0.070 |
| G | 2.54 BSC | | 0.100 BSC | |
| H | 0.76 | 1.27 | 0.030 | 0.050 |
| J | 0.20 | 0.30 | 0.008 | 0.012 |
| K | 2.92 | 3.43 | 0.115 | 0.135 |
| L | 7.62 BSC | | 0.300 BSC | |
| M | — 10° | | — 10° | |
| N | 0.76 | 1.01 | 0.030 | 0.040 |

N, P, N-14, P2 SUFFIX
CASE 646-06
 Plastic Package
 ISSUE L

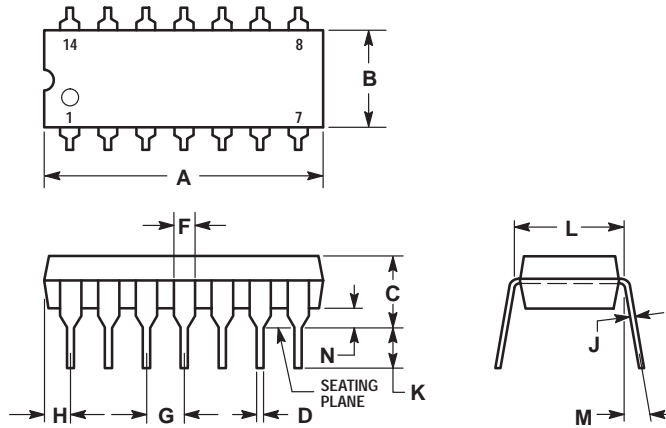
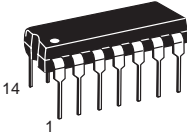

- NOTES:
1. LEADS WITHIN 0.13 (0.005) RADIUS OF TRUE POSITION AT SEATING PLANE AT MAXIMUM MATERIAL CONDITION.
 2. DIMENSION L TO CENTER OF LEADS WHEN FORMED PARALLEL.
 3. DIMENSION B DOES NOT INCLUDE MOLD FLASH.
 4. ROUNDED CORNERS OPTIONAL.

| DIM | INCHES | | MILLIMETERS | |
|-----|-----------|-------|-------------|-------|
| | MIN | MAX | MIN | MAX |
| A | 0.715 | 0.770 | 18.16 | 19.56 |
| B | 0.240 | 0.260 | 6.10 | 6.60 |
| C | 0.145 | 0.185 | 3.69 | 4.69 |
| D | 0.015 | 0.021 | 0.38 | 0.53 |
| F | 0.040 | 0.070 | 1.02 | 1.78 |
| G | 0.100 BSC | | 2.54 BSC | |
| H | 0.052 | 0.095 | 1.32 | 2.41 |
| J | 0.008 | 0.015 | 0.20 | 0.38 |
| K | 0.115 | 0.135 | 2.92 | 3.43 |
| L | 0.300 BSC | | 7.62 BSC | |
| M | 0° 10° | | 0° 10° | |
| N | 0.015 | 0.039 | 0.39 | 1.01 |

DP2, N, P, PC SUFFIX
CASE 648-08
 Plastic Package
 ISSUE R

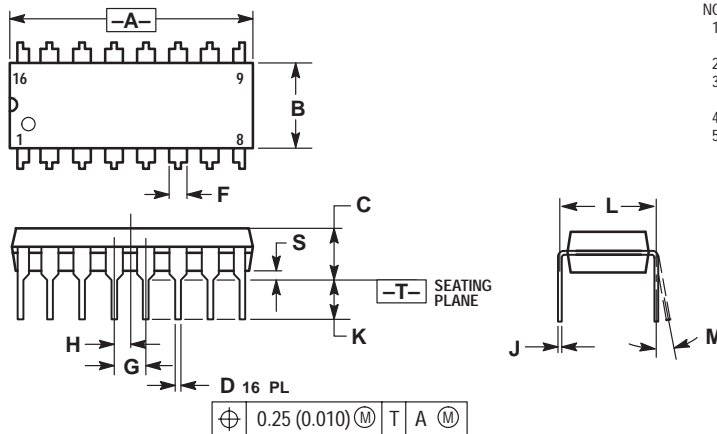
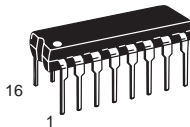

- NOTES:
1. DIMENSIONING AND TOLERANCING PER ANSI Y14.5M, 1982.
 2. CONTROLLING DIMENSION: INCH.
 3. DIMENSION L TO CENTER OF LEADS WHEN FORMED PARALLEL.
 4. DIMENSION B DOES NOT INCLUDE MOLD FLASH.
 5. ROUNDED CORNERS OPTIONAL.

| DIM | INCHES | | MILLIMETERS | |
|-----|-----------|-------|-------------|-------|
| | MIN | MAX | MIN | MAX |
| A | 0.740 | 0.770 | 18.80 | 19.55 |
| B | 0.250 | 0.270 | 6.35 | 6.85 |
| C | 0.145 | 0.175 | 3.69 | 4.44 |
| D | 0.015 | 0.021 | 0.39 | 0.53 |
| F | 0.040 | 0.70 | 1.02 | 1.77 |
| G | 0.100 BSC | | 2.54 BSC | |
| H | 0.050 BSC | | 1.27 BSC | |
| J | 0.008 | 0.015 | 0.21 | 0.38 |
| K | 0.110 | 0.130 | 2.80 | 3.30 |
| L | 0.295 | 0.305 | 7.50 | 7.74 |
| M | 0° 10° | | 0° 10° | |
| S | 0.020 | 0.040 | 0.51 | 1.01 |

B, P, P2, V SUFFIX
CASE 648C-03
 Plastic Package
 (DIP-16)
 ISSUE C

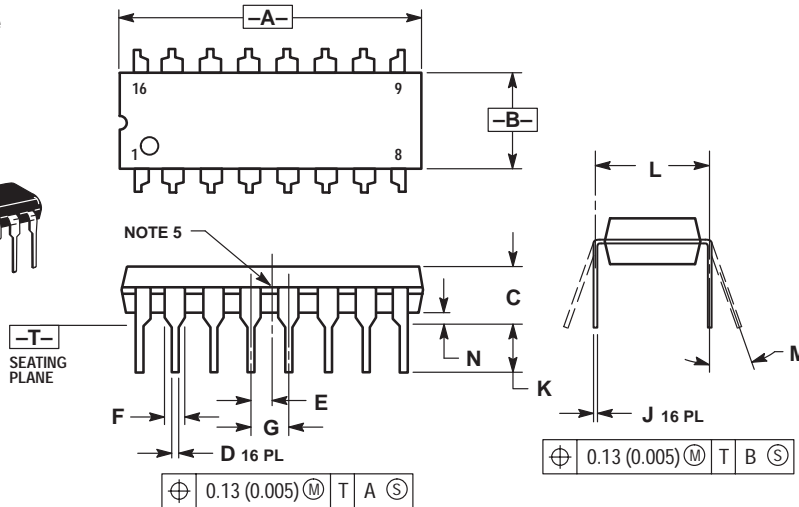
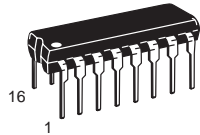

- NOTES:
1. DIMENSIONING AND TOLERANCING PER ANSI Y14.5M, 1982.
 2. CONTROLLING DIMENSION: INCH.
 3. DIMENSION L TO CENTER OF LEADS WHEN FORMED PARALLEL.
 4. DIMENSION B DOES NOT INCLUDE MOLD FLASH.
 5. INTERNAL LEAD CONNECTION BETWEEN 4 AND 5, 12 AND 13.

| DIM | INCHES | | MILLIMETERS | |
|-----|-----------|-------|-------------|-------|
| | MIN | MAX | MIN | MAX |
| A | 0.740 | 0.840 | 18.80 | 21.34 |
| B | 0.240 | 0.260 | 6.10 | 6.60 |
| C | 0.145 | 0.185 | 3.69 | 4.69 |
| D | 0.015 | 0.021 | 0.38 | 0.53 |
| E | 0.050 BSC | | | |
| F | 0.040 | 0.70 | 1.02 | 1.78 |
| G | 0.100 BSC | | | |
| J | 0.008 | 0.015 | 0.20 | 0.38 |
| K | 0.115 | 0.135 | 2.92 | 3.43 |
| L | 0.300 BSC | | | |
| M | 0° | 10° | 0° | 10° |
| N | 0.015 | 0.040 | 0.39 | 1.01 |

P SUFFIX
CASE 648E-01
 Plastic Package
 (DIP-16)
 ISSUE O

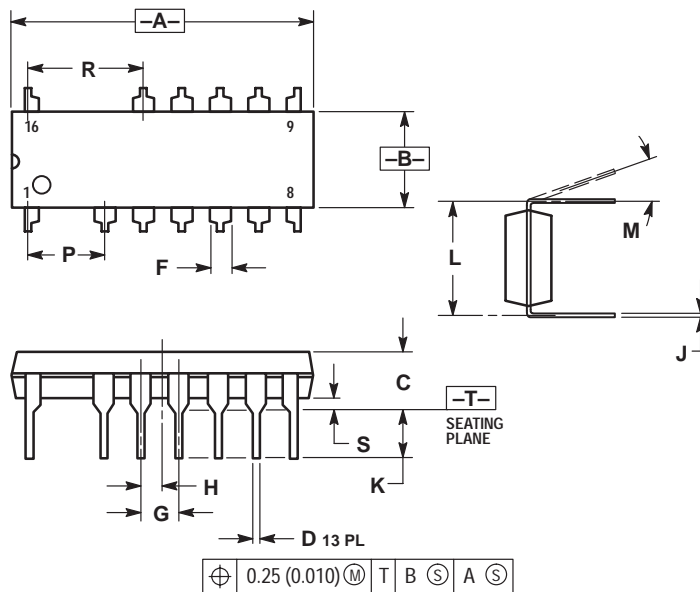
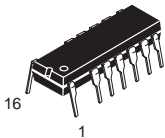

- NOTES:
1. DIMENSIONING AND TOLERANCING PER ANSI Y14.5M, 1982.
 2. CONTROLLING DIMENSION: INCH.
 3. DIMENSION L TO CENTER OF LEADS WHEN FORMED PARALLEL.
 4. DIMENSION A AND B DOES NOT INCLUDE MOLD PROTRUSION.
 5. MOLD FLASH OR PROTRUSIONS SHALL NOT EXCEED 0.25 (0.010).
 6. ROUNDED CORNER OPTIONAL.

| DIM | INCHES | | MILLIMETERS | |
|-----|-----------|-------|-------------|-------|
| | MIN | MAX | MIN | MAX |
| A | 0.740 | 0.760 | 18.80 | 19.30 |
| B | 0.245 | 0.260 | 6.23 | 6.60 |
| C | 0.145 | 0.175 | 3.69 | 4.44 |
| D | 0.015 | 0.021 | 0.39 | 0.53 |
| F | 0.050 | 0.070 | 1.27 | 1.77 |
| G | 0.100 BSC | | | |
| H | 0.050 BSC | | | |
| J | 0.008 | 0.015 | 0.21 | 0.38 |
| K | 0.120 | 0.140 | 3.05 | 3.55 |
| L | 0.295 | 0.305 | 7.50 | 7.74 |
| M | 0° | 10° | 0° | 10° |
| P | 0.200 BSC | | | |
| R | 0.300 BSC | | | |
| S | 0.015 | 0.035 | 0.39 | 0.88 |

P SUFFIX
CASE 649-03
 Plastic Package
 ISSUE D

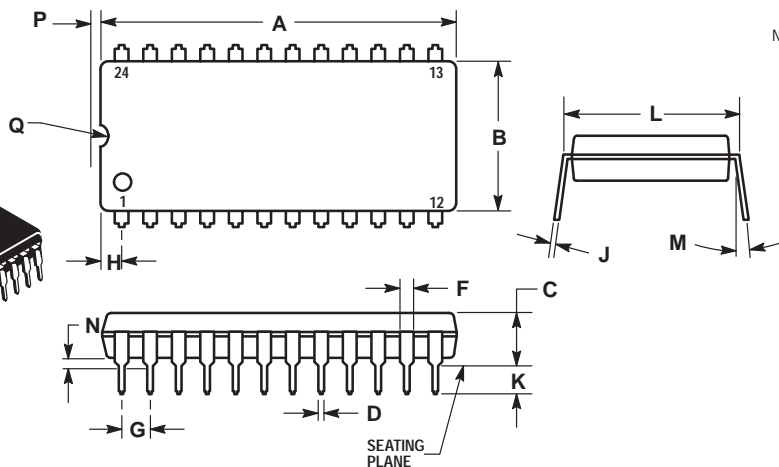
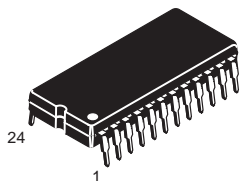

- NOTES:
1. LEADS WITHIN 0.13 (0.005) RADIUS OF TRUE POSITION AT SEATING PLANE AT MAXIMUM MATERIAL CONDITION.
 2. DIMENSION L TO CENTER OF LEADS WHEN FORMED PARALLEL.

| DIM | MILLIMETERS | | INCHES | |
|-----|-------------|-------|-----------|-------|
| | MIN | MAX | MIN | MAX |
| A | 31.50 | 32.13 | 1.240 | 1.265 |
| B | 13.21 | 13.72 | 0.520 | 0.540 |
| C | 4.70 | 5.21 | 0.185 | 0.205 |
| D | 0.38 | 0.51 | 0.015 | 0.020 |
| F | 1.02 | 1.52 | 0.040 | 0.060 |
| G | 2.54 BSC | | 0.100 BSC | |
| H | 1.65 | 2.16 | 0.065 | 0.085 |
| J | 0.20 | 0.30 | 0.008 | 0.012 |
| K | 2.92 | 3.43 | 0.115 | 0.135 |
| L | 14.99 | 15.49 | 0.590 | 0.610 |
| M | --- | 10 | --- | 10° |
| N | 0.51 | 1.02 | 0.020 | 0.040 |
| P | 0.13 | 0.38 | 0.005 | 0.015 |
| Q | 0.51 | 0.76 | 0.020 | 0.030 |

A, B, N, P SUFFIX
CASE 707-02
 Plastic Package
 ISSUE C

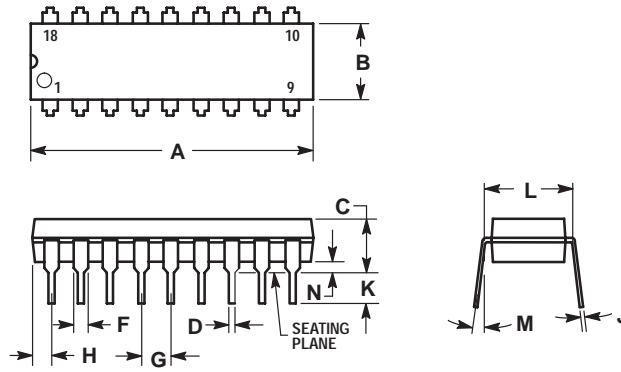
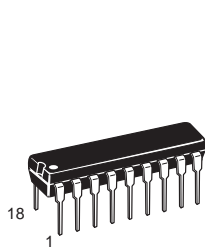

- NOTES:
1. POSITIONAL TOLERANCE OF LEADS (D), SHALL BE WITHIN 0.25 (0.010) AT MAXIMUM MATERIAL CONDITION, IN RELATION TO SEATING PLANE AND EACH OTHER.
 2. DIMENSION L TO CENTER OF LEADS WHEN FORMED PARALLEL.
 3. DIMENSION B DOES NOT INCLUDE MOLD FLASH.

| DIM | MILLIMETERS | | INCHES | |
|-----|-------------|-------|-----------|-------|
| | MIN | MAX | MIN | MAX |
| A | 22.22 | 23.24 | 0.875 | 0.915 |
| B | 6.10 | 6.60 | 0.240 | 0.260 |
| C | 3.56 | 4.57 | 0.140 | 0.180 |
| D | 0.36 | 0.56 | 0.014 | 0.022 |
| F | 1.27 | 1.78 | 0.050 | 0.070 |
| G | 2.54 BSC | | 0.100 BSC | |
| H | 1.02 | 1.52 | 0.040 | 0.060 |
| J | 0.20 | 0.30 | 0.008 | 0.012 |
| K | 2.92 | 3.43 | 0.115 | 0.135 |
| L | 7.62 BSC | | 0.300 BSC | |
| M | 0° | 15° | 0° | 15° |
| N | 0.51 | 1.02 | 0.020 | 0.040 |

P SUFFIX
CASE 710-02
 Plastic Package
 ISSUE B

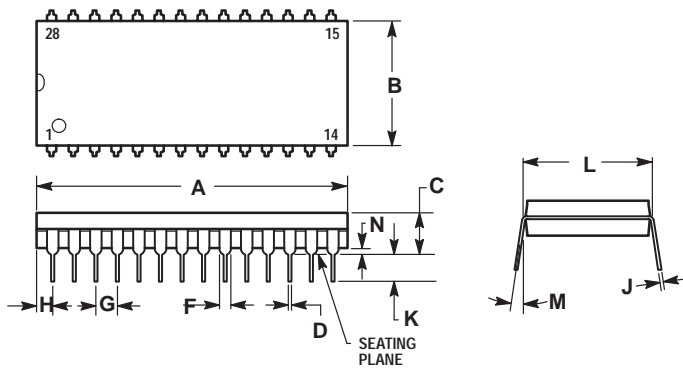
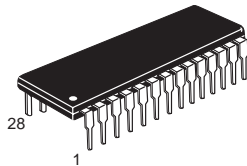

- NOTES:
1. POSITIONAL TOLERANCE OF LEADS (D), SHALL BE WITHIN 0.25 (0.010) AT MAXIMUM MATERIAL CONDITION, IN RELATION TO SEATING PLANE AND EACH OTHER.
 2. DIMENSION L TO CENTER OF LEADS WHEN FORMED PARALLEL.
 3. DIMENSION B DOES NOT INCLUDE MOLD FLASH.

| DIM | MILLIMETERS | | INCHES | |
|-----|-------------|-------|-----------|-------|
| | MIN | MAX | MIN | MAX |
| A | 36.45 | 37.21 | 1.435 | 1.465 |
| B | 13.72 | 14.22 | 0.540 | 0.560 |
| C | 3.94 | 5.08 | 0.155 | 0.200 |
| D | 0.36 | 0.56 | 0.014 | 0.022 |
| F | 1.02 | 1.52 | 0.040 | 0.060 |
| G | 2.54 BSC | | 0.100 BSC | |
| H | 1.65 | 2.16 | 0.065 | 0.085 |
| J | 0.20 | 0.38 | 0.008 | 0.015 |
| K | 2.92 | 3.43 | 0.115 | 0.135 |
| L | 15.24 BSC | | 0.600 BSC | |
| M | 0° | 15° | 0° | 15° |
| N | 0.51 | 1.02 | 0.020 | 0.040 |

P SUFFIX
CASE 711-03
 Plastic Package
 ISSUE C

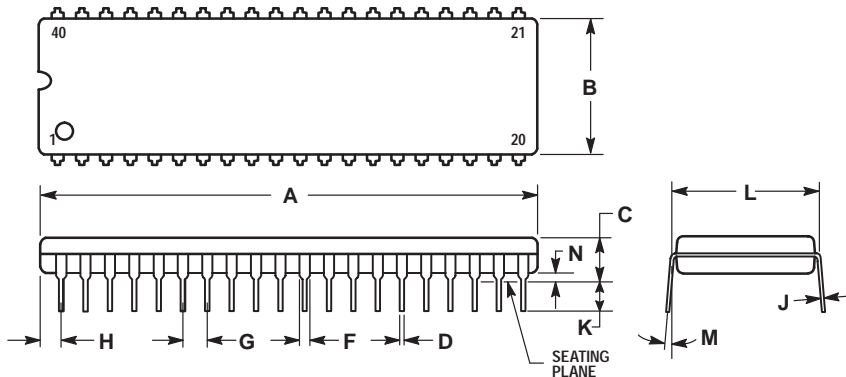
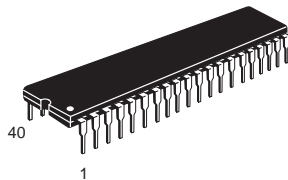

- NOTES:
1. POSITIONAL TOLERANCE OF LEADS (D), SHALL BE WITHIN 0.25 (0.010) AT MAXIMUM MATERIAL CONDITION, IN RELATION TO SEATING PLANE AND EACH OTHER.
 2. DIMENSION L TO CENTER OF LEADS WHEN FORMED PARALLEL.
 3. DIMENSION B DOES NOT INCLUDE MOLD FLASH.

| DIM | MILLIMETERS | | INCHES | |
|-----|-------------|-------|-----------|-------|
| | MIN | MAX | MIN | MAX |
| A | 51.69 | 52.45 | 2.035 | 2.065 |
| B | 13.72 | 14.22 | 0.540 | 0.560 |
| C | 3.94 | 5.08 | 0.155 | 0.200 |
| D | 0.36 | 0.56 | 0.014 | 0.022 |
| F | 1.02 | 1.52 | 0.040 | 0.060 |
| G | 2.54 BSC | | 0.100 BSC | |
| H | 1.65 | 2.16 | 0.065 | 0.085 |
| J | 0.20 | 0.38 | 0.008 | 0.015 |
| K | 2.92 | 3.43 | 0.115 | 0.135 |
| L | 15.24 BSC | | 0.600 BSC | |
| M | 0° | 15° | 0° | 15° |
| N | 0.51 | 1.02 | 0.020 | 0.040 |

F, P, P-3 SUFFIX
CASE 724-03
 Plastic Package
 (NDIP-24)
 ISSUE D

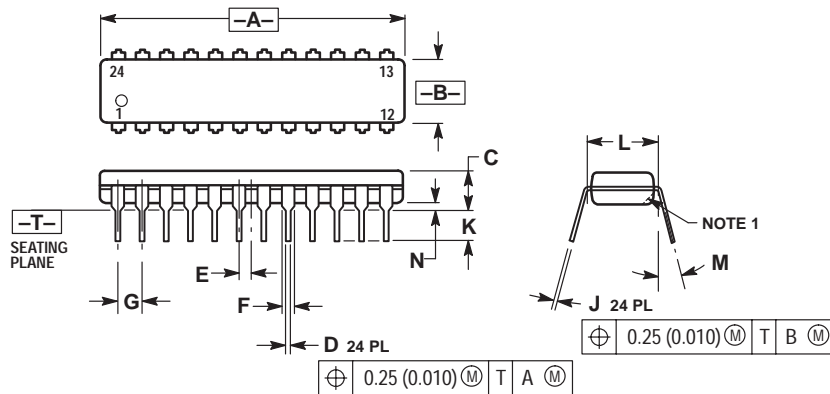
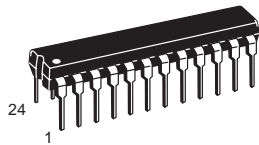

- NOTES:
1. CHAMFERED CONTOUR OPTIONAL.
 2. DIMENSION L TO CENTER OF LEADS WHEN FORMED PARALLEL.
 3. DIMENSIONING AND TOLERANCING PER ANSI Y14.5M, 1982.
 4. CONTROLLING DIMENSION: INCH.

| DIM | INCHES | | MILLIMETERS | |
|-----|-----------|-------|-------------|-------|
| | MIN | MAX | MIN | MAX |
| A | 1.230 | 1.265 | 31.25 | 32.13 |
| B | 0.250 | 0.270 | 6.35 | 6.85 |
| C | 0.145 | 0.175 | 3.69 | 4.44 |
| D | 0.015 | 0.020 | 0.38 | 0.51 |
| E | 0.050 BSC | | 1.27 BSC | |
| F | 0.040 | 0.060 | 1.02 | 1.52 |
| G | 0.100 BSC | | 2.54 BSC | |
| J | 0.007 | 0.012 | 0.18 | 0.30 |
| K | 0.110 | 0.140 | 2.80 | 3.55 |
| L | 0.300 BSC | | 7.62 BSC | |
| M | 0° | 15° | 0° | 15° |
| N | 0.020 | 0.040 | 0.51 | 1.01 |

H, P, DP SUFFIX
CASE 738-03
 Plastic Package
 ISSUE E

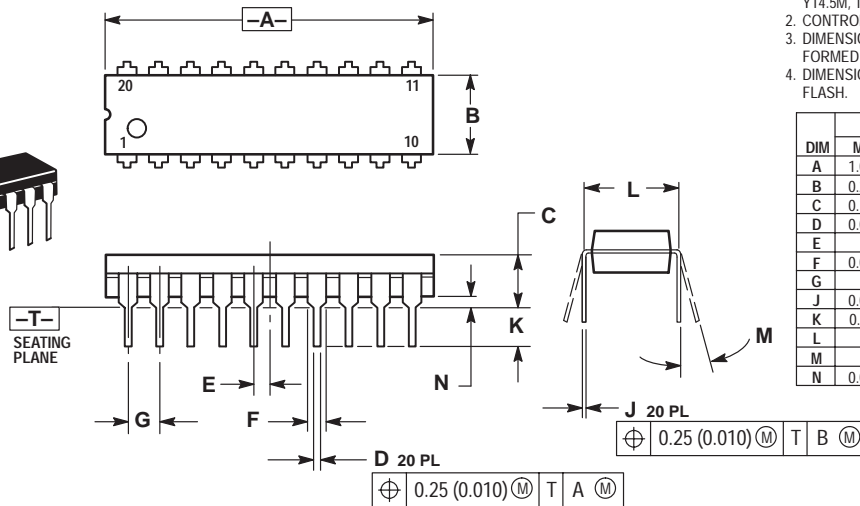
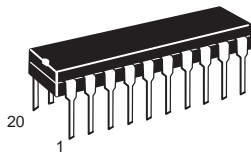

- NOTES:
1. DIMENSIONING AND TOLERANCING PER ANSI Y14.5M, 1982.
 2. CONTROLLING DIMENSION: INCH.
 3. DIMENSION L TO CENTER OF LEAD WHEN FORMED PARALLEL.
 4. DIMENSION B DOES NOT INCLUDE MOLD FLASH.

| DIM | INCHES | | MILLIMETERS | |
|-----|-----------|-------|-------------|-------|
| | MIN | MAX | MIN | MAX |
| A | 1.010 | 1.070 | 25.66 | 27.17 |
| B | 0.240 | 0.260 | 6.10 | 6.60 |
| C | 0.150 | 0.180 | 3.81 | 4.57 |
| D | 0.015 | 0.022 | 0.39 | 0.55 |
| E | 0.050 BSC | | 1.27 BSC | |
| F | 0.050 | 0.070 | 1.27 | 1.77 |
| G | 0.100 BSC | | 2.54 BSC | |
| J | 0.008 | 0.015 | 0.21 | 0.38 |
| K | 0.110 | 0.140 | 2.80 | 3.55 |
| L | 0.300 BSC | | 7.62 BSC | |
| M | 0° | 15° | 0° | 15° |
| N | 0.020 | 0.040 | 0.51 | 1.01 |

D, D1, D2 SUFFIX
CASE 751-05
 Plastic Package
 (SO-8, SOP-8)
 ISSUE R

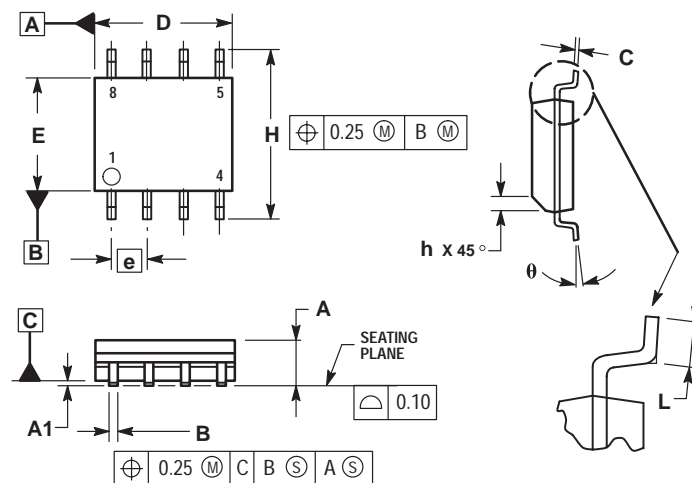

- NOTES:
1. DIMENSIONING AND TOLERANCING PER ASME Y14.5M, 1994.
 2. DIMENSIONS ARE IN MILLIMETERS.
 3. DIMENSION D AND E DO NOT INCLUDE MOLD PROTRUSION.
 4. MAXIMUM MOLD PROTRUSION 0.15 PER SIDE.
 5. DIMENSION B DOES NOT INCLUDE MOLD PROTRUSION. ALLOWABLE DAMBAR PROTRUSION SHALL BE 0.127 TOTAL IN EXCESS OF THE B DIMENSION AT MAXIMUM MATERIAL CONDITION.

| DIM | MILLIMETERS | |
|-----|-------------|------|
| | MIN | MAX |
| A | 1.35 | 1.75 |
| A1 | 0.10 | 0.25 |
| B | 0.35 | 0.49 |
| C | 0.18 | 0.25 |
| D | 4.80 | 5.00 |
| E | 3.80 | 4.00 |
| e | 1.27 BSC | |
| H | 5.80 | 6.20 |
| h | 0.25 | 0.50 |
| L | 0.40 | 1.25 |
| θ | 0° | 7° |

D SUFFIX
CASE 751A-03
 Plastic Package
 (SO-14)
 ISSUE F

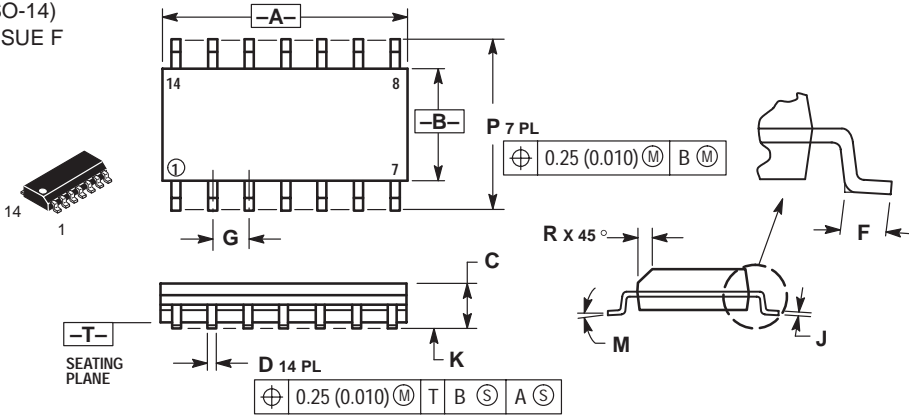

- NOTES:
1. DIMENSIONING AND TOLERANCING PER ANSI Y14.5M, 1982.
 2. CONTROLLING DIMENSION: MILLIMETER.
 3. DIMENSIONS A AND B DO NOT INCLUDE MOLD PROTRUSION.
 4. MAXIMUM MOLD PROTRUSION 0.15 (0.006) PER SIDE.
 5. DIMENSION D DOES NOT INCLUDE DAMBAR PROTRUSION. ALLOWABLE DAMBAR PROTRUSION SHALL BE 0.127 (0.005) TOTAL IN EXCESS OF THE D DIMENSION AT MAXIMUM MATERIAL CONDITION.

| DIM | MILLIMETERS | | INCHES | |
|-----|-------------|------|-----------|-------|
| | MIN | MAX | MIN | MAX |
| A | 8.55 | 8.75 | 0.337 | 0.344 |
| B | 3.80 | 4.00 | 0.150 | 0.157 |
| C | 1.35 | 1.75 | 0.054 | 0.068 |
| D | 0.35 | 0.49 | 0.014 | 0.019 |
| F | 0.40 | 1.25 | 0.016 | 0.049 |
| G | 1.27 BSC | | 0.050 BSC | |
| J | 0.19 | 0.25 | 0.008 | 0.009 |
| K | 0.10 | 0.25 | 0.004 | 0.009 |
| M | 0° | 7° | 0° | 7° |
| P | 5.80 | 6.20 | 0.228 | 0.244 |
| R | 0.25 | 0.50 | 0.010 | 0.019 |

D SUFFIX
CASE 751B-05
 Plastic Package
 (SO-16)
 ISSUE J

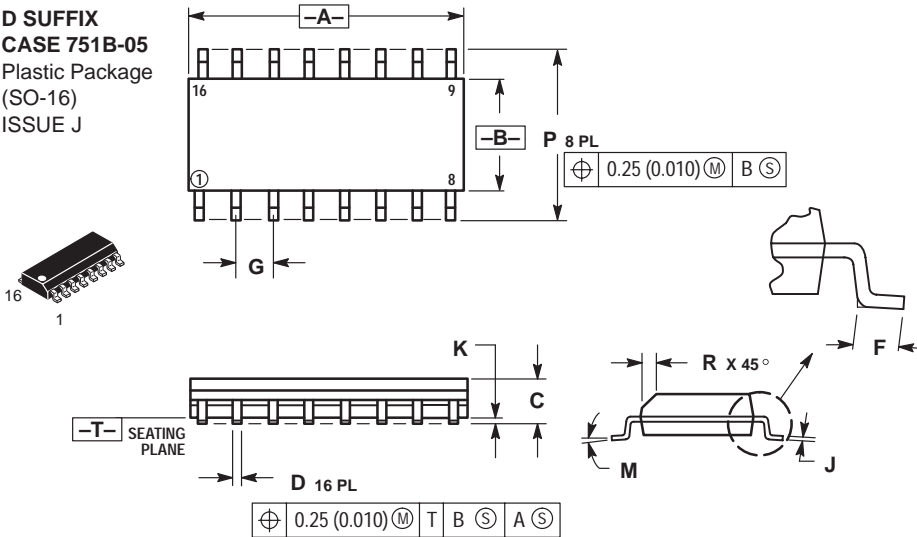

- NOTES:
1. DIMENSIONING AND TOLERANCING PER ANSI Y14.5M, 1982.
 2. CONTROLLING DIMENSION: MILLIMETER.
 3. DIMENSIONS A AND B DO NOT INCLUDE MOLD PROTRUSION.
 4. MAXIMUM MOLD PROTRUSION 0.15 (0.006) PER SIDE.
 5. DIMENSION D DOES NOT INCLUDE DAMBAR PROTRUSION. ALLOWABLE DAMBAR PROTRUSION SHALL BE 0.127 (0.005) TOTAL IN EXCESS OF THE D DIMENSION AT MAXIMUM MATERIAL CONDITION.

| DIM | MILLIMETERS | | INCHES | |
|-----|-------------|-------|-----------|-------|
| | MIN | MAX | MIN | MAX |
| A | 9.80 | 10.00 | 0.386 | 0.393 |
| B | 3.80 | 4.00 | 0.150 | 0.157 |
| C | 1.35 | 1.75 | 0.054 | 0.068 |
| D | 0.35 | 0.49 | 0.014 | 0.019 |
| F | 0.40 | 1.25 | 0.016 | 0.049 |
| G | 1.27 BSC | | 0.050 BSC | |
| J | 0.19 | 0.25 | 0.008 | 0.009 |
| K | 0.10 | 0.25 | 0.004 | 0.009 |
| M | 0° | 7° | 0° | 7° |
| P | 5.80 | 6.20 | 0.229 | 0.244 |
| R | 0.25 | 0.50 | 0.010 | 0.019 |

DW, FP SUFFIX
CASE 751D-04
 Plastic Package
 (SO-20L, SO-20)
 ISSUE E

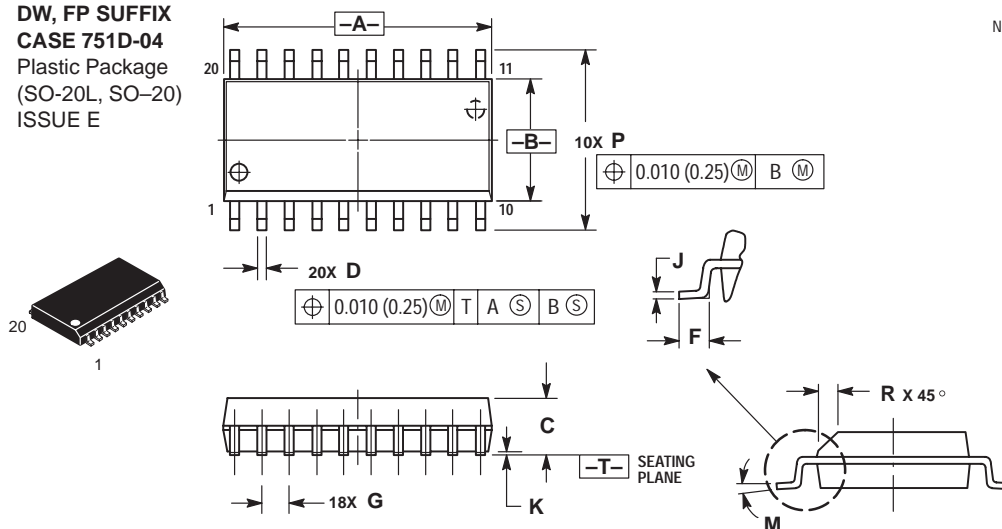

- NOTES:
1. DIMENSIONING AND TOLERANCING PER ANSI Y14.5M, 1982.
 2. CONTROLLING DIMENSION: MILLIMETER.
 3. DIMENSIONS A AND B DO NOT INCLUDE MOLD PROTRUSION.
 4. MAXIMUM MOLD PROTRUSION 0.150 (0.006) PER SIDE.
 5. DIMENSION D DOES NOT INCLUDE DAMBAR PROTRUSION. ALLOWABLE DAMBAR PROTRUSION SHALL BE 0.13 (0.005) TOTAL IN EXCESS OF D DIMENSION AT MAXIMUM MATERIAL CONDITION.

| DIM | MILLIMETERS | | INCHES | |
|-----|-------------|-------|-----------|-------|
| | MIN | MAX | MIN | MAX |
| A | 12.65 | 12.95 | 0.499 | 0.510 |
| B | 7.40 | 7.60 | 0.292 | 0.299 |
| C | 2.35 | 2.65 | 0.093 | 0.104 |
| D | 0.35 | 0.49 | 0.014 | 0.019 |
| F | 0.50 | 0.90 | 0.020 | 0.035 |
| G | 1.27 BSC | | 0.050 BSC | |
| J | 0.25 | 0.32 | 0.010 | 0.012 |
| K | 0.10 | 0.25 | 0.004 | 0.009 |
| M | 0° | 7° | 0° | 7° |
| P | 10.05 | 10.55 | 0.395 | 0.415 |
| R | 0.25 | 0.75 | 0.010 | 0.029 |

DW SUFFIX
CASE 751E-04
 Plastic Package
 (SO-24L,
 SOP (16+4+4)L)
 ISSUE E

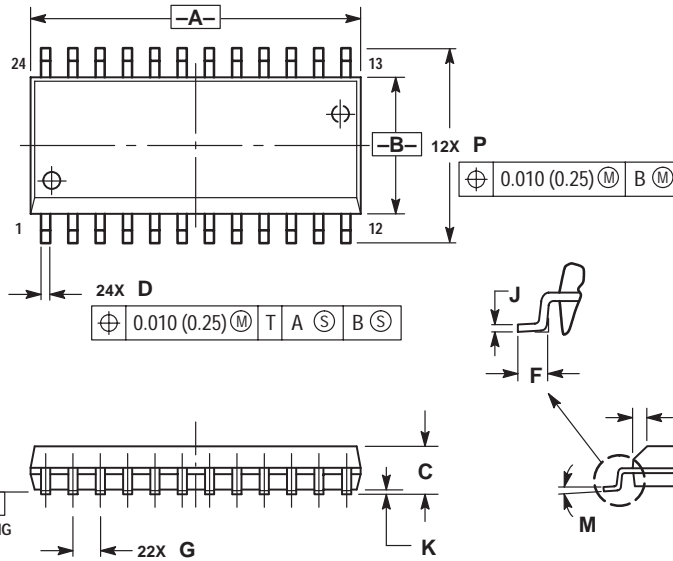
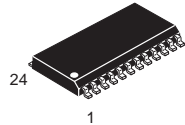

- NOTES:
1. DIMENSIONING AND TOLERANCING PER ANSI Y14.5M, 1982.
 2. CONTROLLING DIMENSION: MILLIMETER.
 3. DIMENSIONS A AND B DO NOT INCLUDE MOLD PROTRUSION.
 4. MAXIMUM MOLD PROTRUSION 0.15 (0.006) PER SIDE.
 5. DIMENSION D DOES NOT INCLUDE DAMBAR PROTRUSION. ALLOWABLE DAMBAR PROTRUSION SHALL BE 0.13 (0.005) TOTAL IN EXCESS OF D DIMENSION AT MAXIMUM MATERIAL CONDITION.

| DIM | MILLIMETERS | | INCHES | |
|-----|-------------|-------|-----------|-------|
| | MIN | MAX | MIN | MAX |
| A | 15.25 | 15.54 | 0.601 | 0.612 |
| B | 7.40 | 7.60 | 0.292 | 0.299 |
| C | 2.35 | 2.65 | 0.093 | 0.104 |
| D | 0.35 | 0.49 | 0.014 | 0.019 |
| F | 0.41 | 0.90 | 0.016 | 0.035 |
| G | 1.27 BSC | | 0.050 BSC | |
| J | 0.23 | 0.32 | 0.009 | 0.013 |
| K | 0.13 | 0.29 | 0.005 | 0.011 |
| M | 0° | 8° | 0° | 8° |
| P | 10.05 | 10.55 | 0.395 | 0.415 |
| R | 0.25 | 0.75 | 0.010 | 0.029 |

DW SUFFIX
CASE 751F-04
 Plastic Package
 (SO-28L, SOIC-28)
 ISSUE E

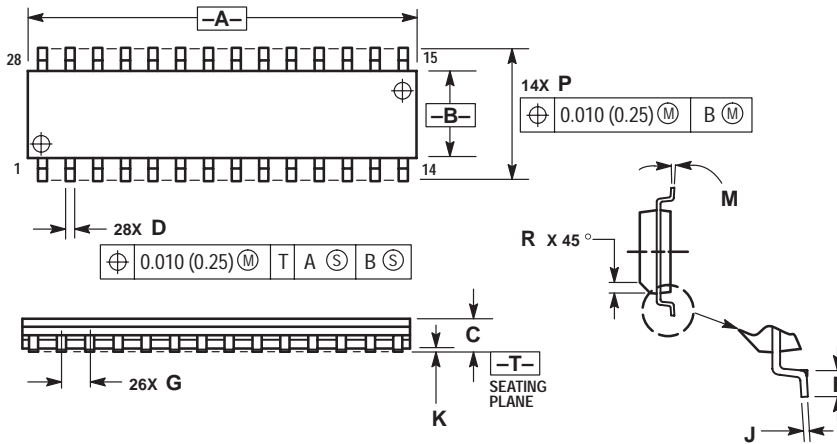
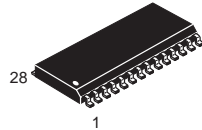

- NOTES:
1. DIMENSIONING AND TOLERANCING PER ANSI Y14.5M, 1982.
 2. CONTROLLING DIMENSION: MILLIMETER.
 3. DIMENSION A AND B DO NOT INCLUDE MOLD PROTRUSION.
 4. MAXIMUM MOLD PROTRUSION 0.15 (0.006) PER SIDE.
 5. DIMENSION D DOES NOT INCLUDE DAMBAR PROTRUSION. ALLOWABLE DAMBAR PROTRUSION SHALL BE 0.13 (0.005) TOTAL IN EXCESS OF D DIMENSION AT MAXIMUM MATERIAL CONDITION.

| DIM | MILLIMETERS | | INCHES | |
|-----|-------------|-------|-----------|-------|
| | MIN | MAX | MIN | MAX |
| A | 17.80 | 18.05 | 0.701 | 0.711 |
| B | 7.40 | 7.60 | 0.292 | 0.299 |
| C | 2.35 | 2.65 | 0.093 | 0.104 |
| D | 0.35 | 0.49 | 0.014 | 0.019 |
| F | 0.41 | 0.90 | 0.016 | 0.035 |
| G | 1.27 BSC | | 0.050 BSC | |
| J | 0.23 | 0.32 | 0.009 | 0.013 |
| K | 0.13 | 0.29 | 0.005 | 0.011 |
| M | 0° | 8° | 0° | 8° |
| P | 10.01 | 10.55 | 0.395 | 0.415 |
| R | 0.25 | 0.75 | 0.010 | 0.029 |

DW SUFFIX
CASE 751G-02
 Plastic Package
 (SO-16L, SOP-16L,
 SOP-8+8L)
 ISSUE A

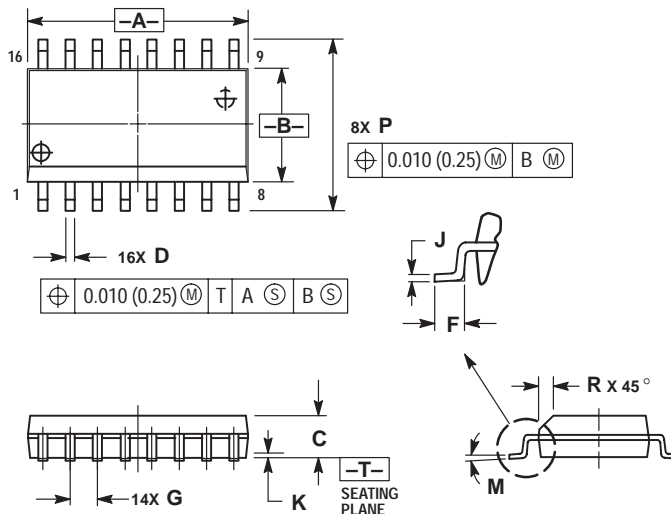
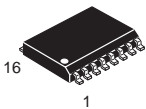

- NOTES:
1. DIMENSIONING AND TOLERANCING PER ANSI Y14.5M, 1982.
 2. CONTROLLING DIMENSION: MILLIMETER.
 3. DIMENSIONS A AND B DO NOT INCLUDE MOLD PROTRUSION.
 4. MAXIMUM MOLD PROTRUSION 0.15 (0.006) PER SIDE.
 5. DIMENSION D DOES NOT INCLUDE DAMBAR PROTRUSION. ALLOWABLE DAMBAR PROTRUSION SHALL BE 0.13 (0.005) TOTAL IN EXCESS OF D DIMENSION AT MAXIMUM MATERIAL CONDITION.

| DIM | MILLIMETERS | | INCHES | |
|-----|-------------|-------|-----------|-------|
| | MIN | MAX | MIN | MAX |
| A | 10.15 | 10.45 | 0.400 | 0.411 |
| B | 7.40 | 7.60 | 0.292 | 0.299 |
| C | 2.35 | 2.65 | 0.093 | 0.104 |
| D | 0.35 | 0.49 | 0.014 | 0.019 |
| F | 0.50 | 0.90 | 0.020 | 0.035 |
| G | 1.27 BSC | | 0.050 BSC | |
| J | 0.25 | 0.32 | 0.010 | 0.012 |
| K | 0.10 | 0.25 | 0.004 | 0.009 |
| M | 0° | 7° | 0° | 7° |
| P | 10.05 | 10.55 | 0.395 | 0.415 |
| R | 0.25 | 0.75 | 0.010 | 0.029 |

D SUFFIX
CASE 751K-01
 Plastic Package
 (SO-16)
 ISSUE O

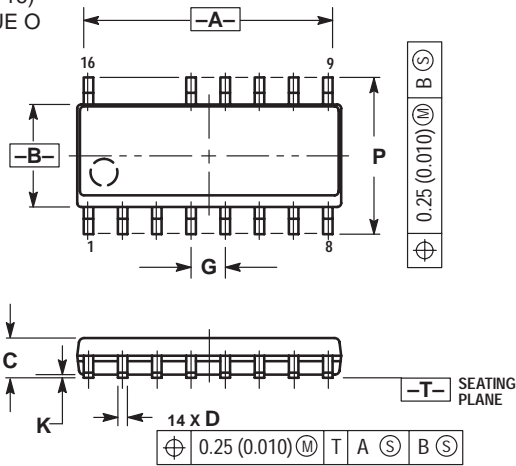
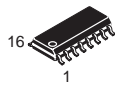

NOTES:

1. DIMENSIONING AND TOLERANCING PER ANSI Y14.5M, 1982.
2. CONTROLLING DIMENSION: MILLIMETER.
3. DIMENSIONS A AND B DO NOT INCLUDE MOLD PROTRUSION.
4. MAXIMUM MOLD PROTRUSION 0.15 (0.006) PER SIDE.
5. DIMENSION D DOES NOT INCLUDE DAMBAR PROTRUSION. ALLOWABLE DAMBAR PROTRUSION SHALL BE 0.127 (0.005) TOTAL IN EXCESS OF THE D DIMENSION AT MAXIMUM MATERIAL CONDITION.

| DIM | MILLIMETERS | | INCHES | |
|-----|-------------|-------|-----------|-------|
| | MIN | MAX | MIN | MAX |
| A | 9.80 | 10.00 | 0.368 | 0.393 |
| B | 3.80 | 4.00 | 0.150 | 0.157 |
| C | 1.35 | 1.75 | 0.054 | 0.068 |
| D | 0.35 | 0.49 | 0.014 | 0.019 |
| F | 0.40 | 1.25 | 0.016 | 0.049 |
| G | 1.27 BSC | | 0.050 BSC | |
| J | 0.19 | 0.25 | 0.008 | 0.009 |
| K | 0.10 | 0.25 | 0.004 | 0.009 |
| M | 0° | 7° | 0° | 7° |
| P | 5.80 | 6.20 | 0.229 | 0.244 |
| R | 0.25 | 0.50 | 0.010 | 0.019 |

DW SUFFIX
CASE 751N-01
 Plastic Package
 (SOP-16L)
 ISSUE O

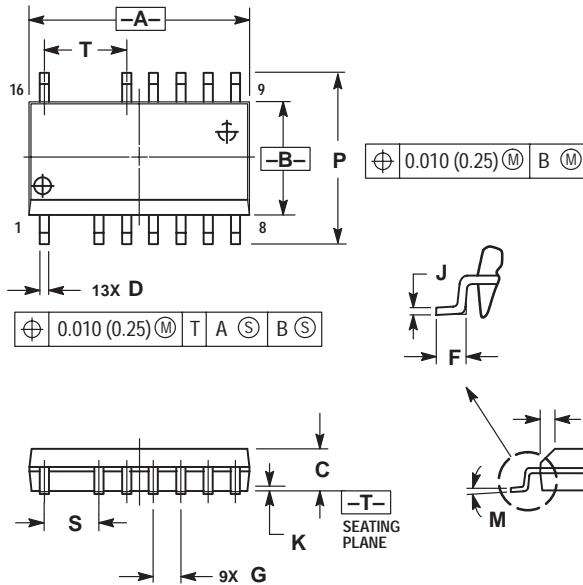
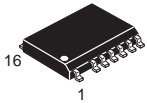

NOTES:

1. DIMENSIONING AND TOLERANCING PER ANSI Y14.5M, 1982.
2. CONTROLLING DIMENSION: MILLIMETER.
3. DIMENSIONS A AND B DO NOT INCLUDE MOLD PROTRUSION.
4. MAXIMUM MOLD PROTRUSION 0.15 (0.006) PER SIDE.
5. DIMENSION D DOES NOT INCLUDE DAMBAR PROTRUSION. ALLOWABLE DAMBAR PROTRUSION SHALL BE 0.13 (0.005) TOTAL IN EXCESS OF D DIMENSION AT MAXIMUM MATERIAL CONDITION.

| DIM | MILLIMETERS | | INCHES | |
|-----|-------------|-------|-----------|-------|
| | MIN | MAX | MIN | MAX |
| A | 10.15 | 10.45 | 0.400 | 0.411 |
| B | 7.40 | 7.60 | 0.292 | 0.299 |
| C | 2.35 | 2.65 | 0.093 | 0.104 |
| D | 0.35 | 0.49 | 0.014 | 0.019 |
| F | 0.50 | 0.90 | 0.020 | 0.035 |
| G | 1.27 BSC | | 0.050 BSC | |
| J | 0.25 | 0.32 | 0.010 | 0.012 |
| K | 0.10 | 0.25 | 0.004 | 0.009 |
| M | 0° | 7° | 0° | 7° |
| P | 10.05 | 10.55 | 0.395 | 0.415 |
| R | 0.25 | 0.75 | 0.010 | 0.029 |
| S | 2.54 BSC | | 0.100 BSC | |
| T | 3.81 BSC | | 0.150 BSC | |

CASE 762-01
 Plastic Medium Power Package
 (SIP-9)
 ISSUE C

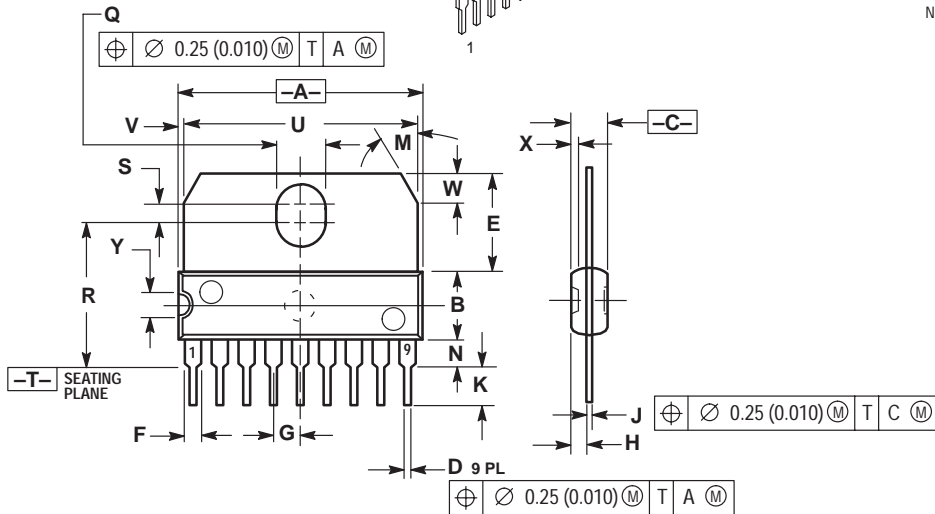
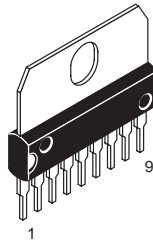

- NOTES:
 1. DIMENSIONING AND TOLERANCING PER ANSI Y14.5, 1982.
 2. CONTROLLING DIMENSION: MILLIMETER.

| DIM | MILLIMETERS | | INCHES | |
|-----|-------------|-------|-----------|-------|
| | MIN | MAX | MIN | MAX |
| A | 22.40 | 23.00 | 0.873 | 0.897 |
| B | 6.40 | 6.60 | 0.252 | 0.260 |
| C | 3.45 | 3.65 | 0.135 | 1.143 |
| D | 0.40 | 0.55 | 0.015 | 0.021 |
| E | 9.35 | 9.60 | 0.368 | 0.377 |
| F | 1.40 | 1.60 | 0.055 | 0.062 |
| G | 2.54 BSC | | 0.100 BSC | |
| H | 1.51 | 1.71 | 0.059 | 0.067 |
| J | 0.360 | 0.400 | 0.014 | 0.015 |
| K | 3.95 | 4.20 | 0.155 | 0.165 |
| M | 30° BSC | | 30° BSC | |
| N | 2.50 | 2.70 | 0.099 | 0.106 |
| Q | 3.15 | 3.45 | 0.124 | 0.135 |
| R | 13.60 | 13.90 | 0.535 | 0.547 |
| S | 1.65 | 1.95 | 0.064 | 0.076 |
| U | 22.00 | 22.20 | 0.866 | 0.874 |
| V | 0.55 | 0.75 | 0.021 | 0.029 |
| W | 2.89 BSC | | 0.113 BSC | |
| X | 0.65 | 0.75 | 0.025 | 0.029 |
| Y | 2.70 | 2.80 | 0.106 | 0.110 |

FN SUFFIX
CASE 775-02
 Plastic Package
 (PLCC-20)
 ISSUE C

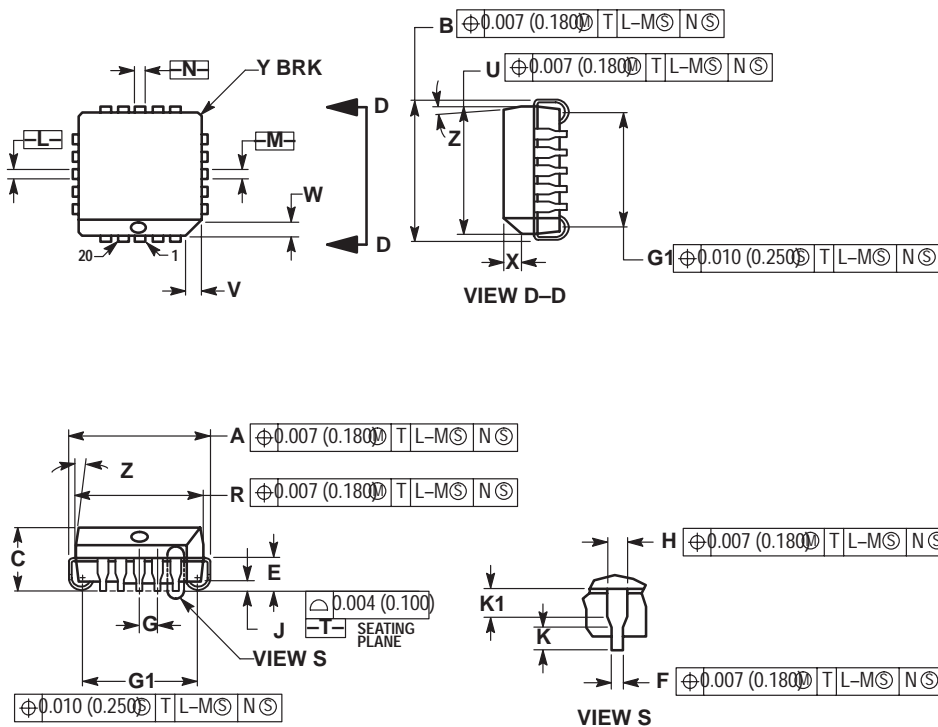
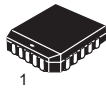

- NOTES:
 1. DATUMS -L-, -M-, AND -N- DETERMINED WHERE TOP OF LEAD SHOULDER EXITS PLASTIC BODY AT MOLD PARTING LINE.
 2. DIMENSION G1, TRUE POSITION TO BE MEASURED AT DATUM -T-, SEATING PLANE.
 3. DIMENSIONS R AND U DO NOT INCLUDE MOLD FLASH. ALLOWABLE MOLD FLASH IS 0.010 (0.250) PER SIDE.
 4. DIMENSIONING AND TOLERANCING PER ANSI Y14.5M, 1982.
 5. CONTROLLING DIMENSION: INCH.
 6. THE PACKAGE TOP MAY BE SMALLER THAN THE PACKAGE BOTTOM BY UP TO 0.012 (0.300). DIMENSIONS R AND U ARE DETERMINED AT THE OUTERMOST EXTREMES OF THE PLASTIC BODY EXCLUSIVE OF MOLD FLASH, TIE BAR BURRS, GATE BURRS AND INTERLEAD FLASH, BUT INCLUDING ANY MISMATCH BETWEEN THE TOP AND BOTTOM OF THE PLASTIC BODY.
 7. DIMENSION H DOES NOT INCLUDE DAMBAR PROTRUSION OR INTRUSION. THE DAMBAR PROTRUSION(S) SHALL NOT CAUSE THE H DIMENSION TO BE GREATER THAN 0.037 (0.940). THE DAMBAR INTRUSION(S) SHALL NOT CAUSE THE H DIMENSION TO BE SMALLER THAN 0.025 (0.635).

| DIM | INCHES | | MILLIMETERS | |
|-----|-----------|-------|-------------|-------|
| | MIN | MAX | MIN | MAX |
| A | 0.385 | 0.395 | 9.78 | 10.03 |
| B | 0.385 | 0.395 | 9.78 | 10.03 |
| C | 0.165 | 0.180 | 4.20 | 4.57 |
| E | 0.090 | 0.110 | 2.29 | 2.79 |
| F | 0.013 | 0.019 | 0.33 | 0.48 |
| G | 0.050 BSC | | 1.27 BSC | |
| H | 0.026 | 0.032 | 0.66 | 0.81 |
| J | 0.020 | --- | 0.51 | --- |
| K | 0.025 | --- | 0.64 | --- |
| R | 0.350 | 0.356 | 8.89 | 9.04 |
| U | 0.350 | 0.356 | 8.89 | 9.04 |
| V | 0.042 | 0.048 | 1.07 | 1.21 |
| W | 0.042 | 0.048 | 1.07 | 1.21 |
| X | 0.042 | 0.056 | 1.07 | 1.42 |
| Y | --- | 0.020 | --- | 0.50 |
| Z | 2° | 10° | --- | 10° |
| G1 | 0.310 | 0.330 | 7.88 | 8.38 |
| K1 | 0.040 | --- | 1.02 | --- |

FN SUFFIX
CASE 776-02
 Plastic Package
 (PLCC-28)
 ISSUE D

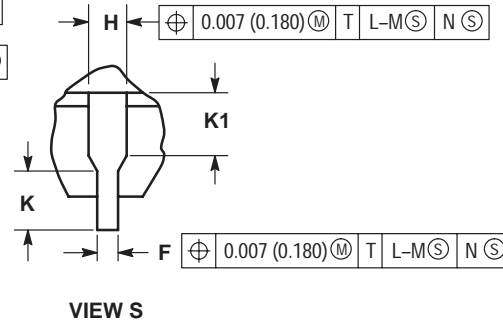
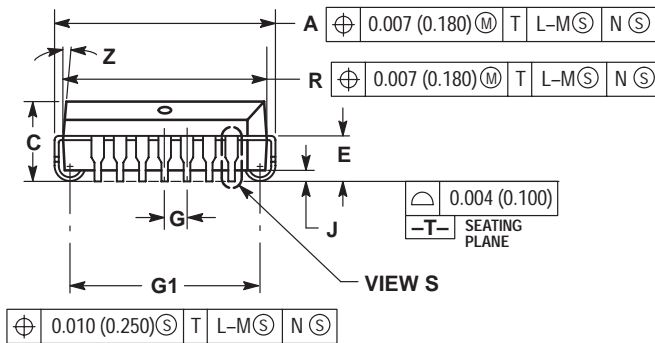
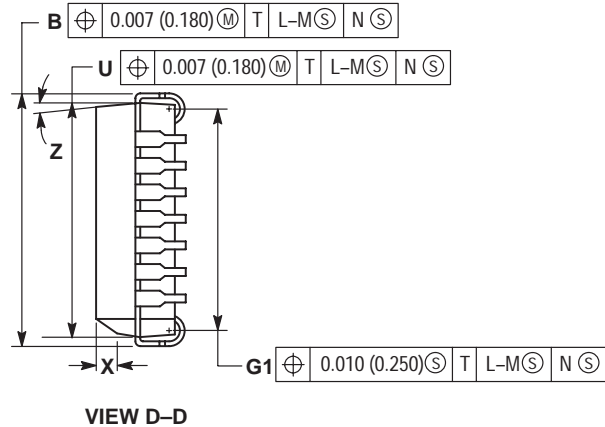
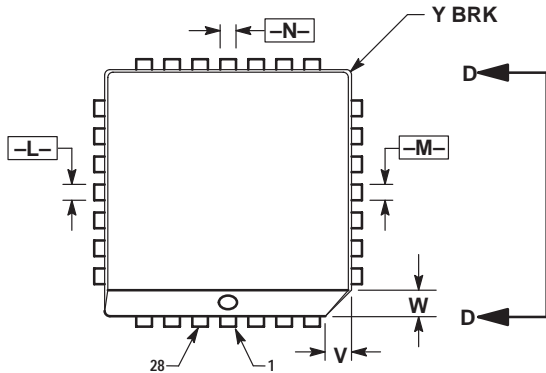
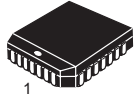

NOTES:

- DATUMS -L-, -M-, AND -N- DETERMINED WHERE TOP OF LEAD SHOULDER EXITS PLASTIC BODY AT MOLD PARTING LINE.
- DIMENSION G1, TRUE POSITION TO BE MEASURED AT DATUM -T-, SEATING PLANE.
- DIMENSIONS R AND U DO NOT INCLUDE MOLD FLASH. ALLOWABLE MOLD FLASH IS 0.010 (0.250) PER SIDE.
- DIMENSIONING AND TOLERANCING PER ANSI Y14.5M, 1982.
- CONTROLLING DIMENSION: INCH.
- THE PACKAGE TOP MAY BE SMALLER THAN THE PACKAGE BOTTOM BY UP TO 0.012 (0.300). DIMENSIONS R AND U ARE DETERMINED AT THE OUTERMOST EXTREMES OF THE PLASTIC BODY EXCLUSIVE OF MOLD FLASH, TIE BAR BURRS, GATE BURRS AND INTERLEAD FLASH, BUT INCLUDING ANY MISMATCH BETWEEN THE TOP AND BOTTOM OF THE PLASTIC BODY.
- DIMENSION H DOES NOT INCLUDE DAMBAR PROTRUSION OR INTRUSION. THE DAMBAR PROTRUSION(S) SHALL NOT CAUSE THE H DIMENSION TO BE GREATER THAN 0.037 (0.940). THE DAMBAR INTRUSION(S) SHALL NOT CAUSE THE H DIMENSION TO BE SMALLER THAN 0.025 (0.635).

| DIM | INCHES | | MILLIMETERS | |
|-----|-----------|-------|-------------|-------|
| | MIN | MAX | MIN | MAX |
| A | 0.485 | 0.495 | 12.32 | 12.57 |
| B | 0.485 | 0.495 | 12.32 | 12.57 |
| C | 0.165 | 0.180 | 4.20 | 4.57 |
| E | 0.090 | 0.110 | 2.29 | 2.79 |
| F | 0.013 | 0.019 | 0.33 | 0.48 |
| G | 0.050 BSC | | 1.27 BSC | |
| H | 0.026 | 0.032 | 0.66 | 0.81 |
| J | 0.020 | --- | 0.51 | --- |
| K | 0.025 | --- | 0.64 | --- |
| R | 0.450 | 0.456 | 11.43 | 11.58 |
| U | 0.450 | 0.456 | 11.43 | 11.58 |
| V | 0.042 | 0.048 | 1.07 | 1.21 |
| W | 0.042 | 0.048 | 1.07 | 1.21 |
| X | 0.042 | 0.056 | 1.07 | 1.42 |
| Y | --- | 0.020 | --- | 0.50 |
| Z | 2° | 10° | 2° | 10° |
| G1 | 0.410 | 0.430 | 10.42 | 10.92 |
| K1 | 0.040 | --- | 1.02 | --- |

FN SUFFIX
CASE 777-02
 Plastic Package
 (PLCC)
 ISSUE C

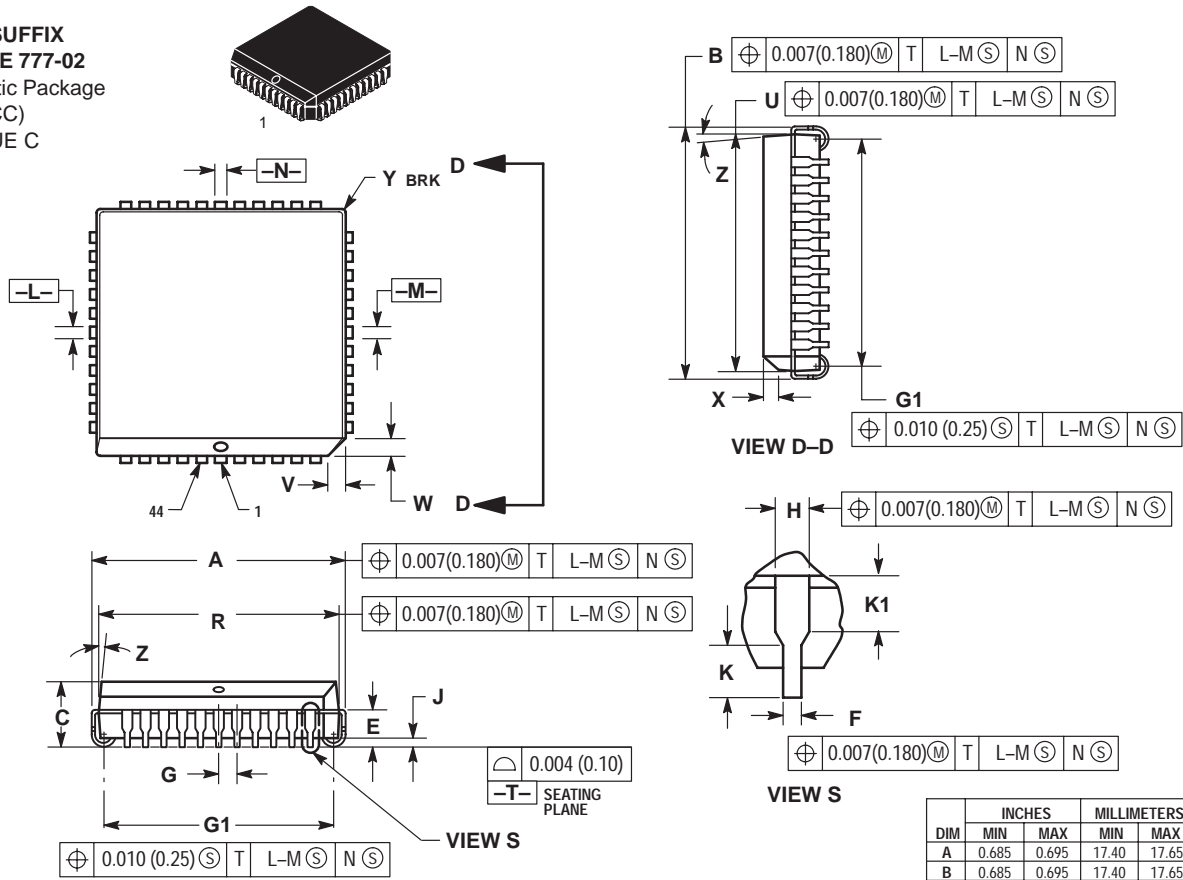

- NOTES:
- DATUMS -L-, -M-, AND -N- ARE DETERMINED WHERE TOP OF LEAD SHOULDER EXITS PLASTIC BODY AT MOLD PARTING LINE.
 - DIMENSION G1, TRUE POSITION TO BE MEASURED AT DATUM -T-, SEATING PLANE.
 - DIMENSIONS R AND U DO NOT INCLUDE MOLD FLASH. ALLOWABLE MOLD FLASH IS 0.010 (0.25) PER SIDE.
 - DIMENSIONING AND TOLERANCING PER ANSI Y14.5M, 1982.
 - CONTROLLING DIMENSION: INCH.

- THE PACKAGE TOP MAY BE SMALLER THAN THE PACKAGE BOTTOM BY UP TO 0.012 (0.300). DIMENSIONS R AND U ARE DETERMINED AT THE OUTERMOST EXTREMES OF THE PLASTIC BODY EXCLUSIVE OF MOLD FLASH, TIE BAR BURRS, GATE BURRS AND INTERLEAD FLASH, BUT INCLUDING ANY MISMATCH BETWEEN THE TOP AND BOTTOM OF THE PLASTIC BODY.
- DIMENSION H DOES NOT INCLUDE DAMBAR PROTRUSION OR INTRUSION. THE DAMBAR PROTRUSION(S) SHALL NOT CAUSE THE H DIMENSION TO BE GREATER THAN 0.037 (0.940). THE DAMBAR INTRUSION(S) SHALL NOT CAUSE THE H DIMENSION TO BE SMALLER THAN 0.025 (0.635).

| DIM | INCHES | | MILLIMETERS | |
|-----|-----------|-------|-------------|-------|
| | MIN | MAX | MIN | MAX |
| A | 0.685 | 0.695 | 17.40 | 17.65 |
| B | 0.685 | 0.695 | 17.40 | 17.65 |
| C | 0.165 | 0.180 | 4.20 | 4.57 |
| E | 0.090 | 0.110 | 2.29 | 2.79 |
| F | 0.013 | 0.019 | 0.33 | 0.48 |
| G | 0.050 BSC | | 1.27 BSC | |
| H | 0.026 | 0.032 | 0.66 | 0.81 |
| J | 0.020 | --- | 0.51 | --- |
| K | 0.025 | --- | 0.64 | --- |
| R | 0.650 | 0.656 | 16.51 | 16.66 |
| U | 0.650 | 0.656 | 16.51 | 16.66 |
| V | 0.042 | 0.048 | 1.07 | 1.21 |
| W | 0.042 | 0.048 | 1.07 | 1.21 |
| X | 0.042 | 0.056 | 1.07 | 1.42 |
| Y | --- | 0.020 | --- | 0.50 |
| Z | 2° | 10° | 2° | 10° |
| G1 | 0.610 | 0.630 | 15.50 | 16.00 |
| K1 | 0.040 | --- | 1.02 | --- |

M SUFFIX
CASE 803C
PRELIMINARY
 Plastic Package

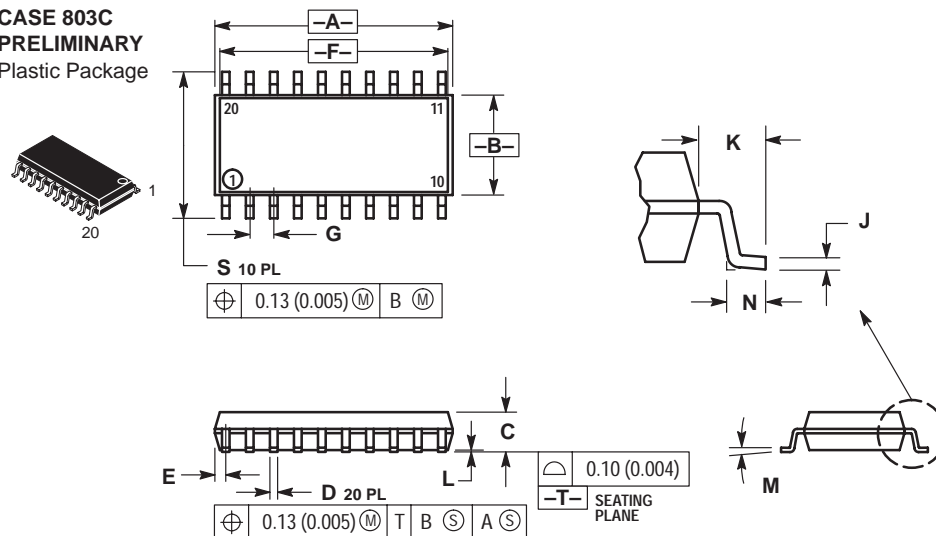

- NOTES:
- DIMENSIONING AND TOLERANCING PER ANSI Y14.5M, 1982.
 - CONTROLLING DIMENSION: MILLIMETER.
 - DIMENSIONS A AND B DO NOT INCLUDE MOLD PROTRUSION.
 - MAXIMUM MOLD PROTRUSION 0.15 (0.008) PER SIDE.
 - DIMENSION D DOES NOT INCLUDE DAMBAR PROTRUSION. ALLOWABLE DAMBAR PROTRUSION SHALL BE 0.13 (0.006) TOTAL IN EXCESS OF THE D DIMENSION AT MAXIMUM MATERIAL CONDITION.

| DIM | MILLIMETERS | | INCHES | |
|-----|-------------|-------|--------|-------|
| | MIN | MAX | MIN | MAX |
| A | 12.35 | 12.80 | 0.486 | 0.504 |
| B | 5.10 | 5.45 | 0.201 | 0.215 |
| C | 1.95 | 2.05 | 0.077 | 0.081 |
| D | 0.35 | 0.50 | 0.014 | 0.020 |
| E | --- | 0.81 | --- | 0.032 |
| F | 12.40* | | 0.488* | |
| G | 1.15 | 1.39 | 0.045 | 0.055 |
| H | 0.59 | 0.81 | 0.023 | 0.032 |
| J | 0.18 | 0.27 | 0.007 | 0.011 |
| K | 1.10 | 1.50 | 0.043 | 0.059 |
| L | 0.05 | 0.20 | 0.001 | 0.008 |
| M | 0° | 10° | 0° | 10° |
| N | 0.50 | 0.85 | 0.020 | 0.033 |
| S | 7.40 | 8.20 | 0.291 | 0.323 |

*APPROXIMATE

TV SUFFIX
CASE 821C-04
 Plastic Package
 (15-Pin ZIP)
 ISSUE D

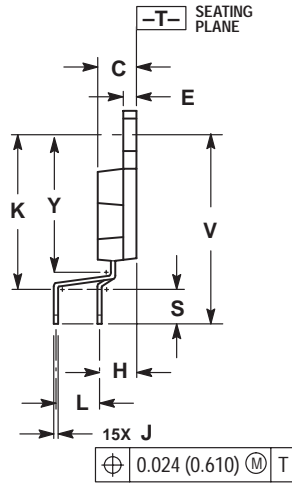
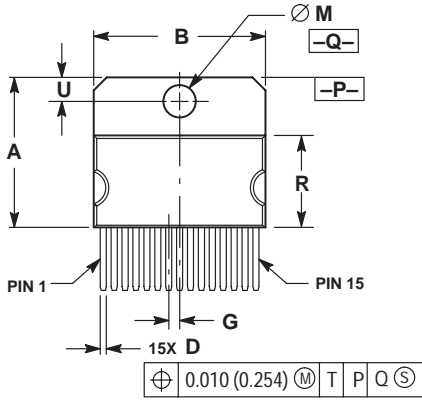
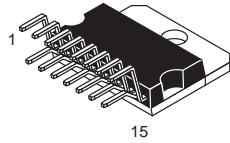

- NOTES:
1. DIMENSIONING AND TOLERANCING PER ANSI Y14.5M, 1982.
 2. CONTROLLING DIMENSION: INCH.
 3. DIMENSION R DOES NOT INCLUDE MOLD FLASH OR PROTRUSIONS.
 4. DIMENSION B DOES NOT INCLUDE MOLD FLASH OR PROTRUSIONS.
 5. MOLD FLASH OR PROTRUSIONS SHALL NOT EXCEED 0.010 (0.250).
 6. DIMENSION D DOES NOT INCLUDE DAMBAR PROTRUSION. ALLOWABLE PROTRUSION SHALL BE 0.003 (0.076) TOTAL IN EXCESS OF THE D DIMENSION, AT MAXIMUM MATERIAL CONDITION.

| DIM | INCHES | | MILLIMETERS | |
|-----|-----------|-------|-------------|--------|
| | MIN | MAX | MIN | MAX |
| A | 0.684 | 0.694 | 17.374 | 17.627 |
| B | 0.784 | 0.792 | 19.914 | 20.116 |
| C | 0.173 | 0.181 | 4.395 | 4.597 |
| D | 0.024 | 0.031 | 0.610 | 0.787 |
| E | 0.058 | 0.062 | 1.473 | 1.574 |
| G | 0.050 BSC | | 1.270 BSC | |
| H | 0.169 BSC | | 4.293 BSC | |
| J | 0.018 | 0.024 | 0.458 | 0.609 |
| K | 0.700 | 0.710 | 17.780 | 18.034 |
| L | 0.200 BSC | | 5.080 BSC | |
| M | 0.148 | 0.151 | 3.760 | 3.835 |
| R | 0.416 | 0.426 | 10.567 | 10.820 |
| S | 0.157 | 0.167 | 3.988 | 4.242 |
| U | 0.105 | 0.115 | 2.667 | 2.921 |
| V | 0.868 REF | | 22.047 REF | |
| Y | 0.625 | 0.639 | 15.875 | 16.231 |

T SUFFIX
CASE 821D-03
 Plastic Package
 ISSUE C

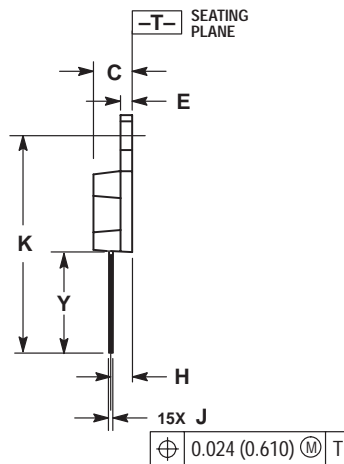
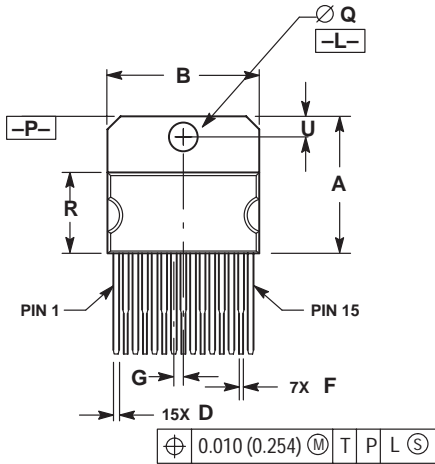
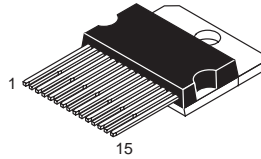

- NOTES:
1. DIMENSIONING AND TOLERANCING PER ANSI Y14.5M, 1982.
 2. CONTROLLING DIMENSION: INCH.
 3. DIMENSION R DOES NOT INCLUDE MOLD FLASH OR PROTRUSIONS.
 4. DIMENSION B DOES NOT INCLUDE MOLD FLASH OR PROTRUSIONS.
 5. MOLD FLASH OR PROTRUSIONS SHALL NOT EXCEED 0.010 (0.250).
 6. DELETED
 7. DIMENSION D DOES NOT INCLUDE DAMBAR PROTRUSION. ALLOWABLE PROTRUSION SHALL BE 0.003 (0.076) TOTAL IN EXCESS OF THE D DIMENSION, AT MAXIMUM MATERIAL CONDITION.

| DIM | INCHES | | MILLIMETERS | |
|-----|-----------|-------|-------------|--------|
| | MIN | MAX | MIN | MAX |
| A | 0.681 | 0.694 | 17.298 | 17.627 |
| B | 0.784 | 0.792 | 19.914 | 20.116 |
| C | 0.173 | 0.181 | 4.395 | 4.597 |
| D | 0.024 | 0.031 | 0.610 | 0.787 |
| E | 0.058 | 0.062 | 1.473 | 1.574 |
| F | 0.016 | 0.023 | 0.407 | 0.584 |
| G | 0.050 BSC | | 1.270 BSC | |
| H | 0.110 BSC | | 2.794 BSC | |
| J | 0.018 | 0.024 | 0.458 | 0.609 |
| K | 1.078 | 1.086 | 27.382 | 27.584 |
| Q | 0.148 | 0.151 | 3.760 | 3.835 |
| R | 0.416 | 0.426 | 10.567 | 10.820 |
| U | 0.110 BSC | | 2.794 BSC | |
| Y | 0.503 REF | | 12.776 REF | |

FTB SUFFIX
CASE 824D-01
 Plastic Package
 (TQFP-44)
 ISSUE O

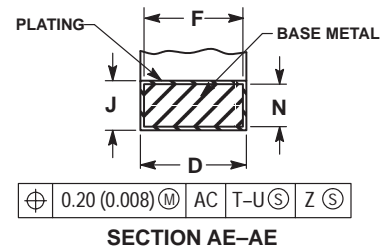
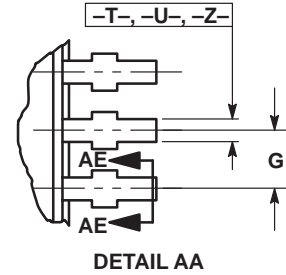
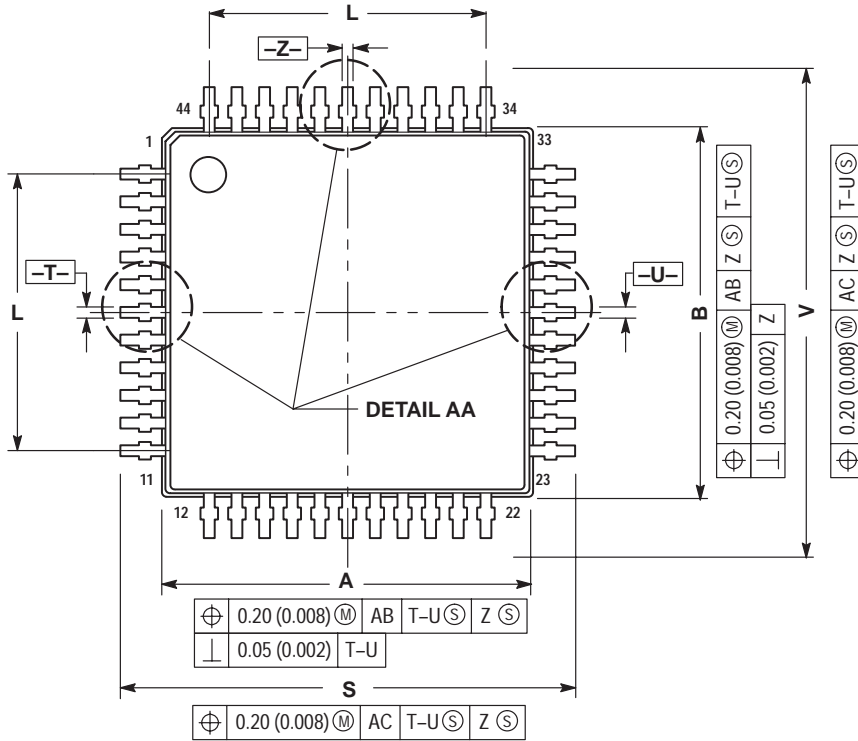
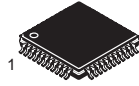

- NOTES:
1. DIMENSIONING AND TOLERANCING PER ANSI Y14.5M, 1982.
 2. CONTROLLING DIMENSION: MILLIMETER.
 3. DATUM PLANE -AB- IS LOCATED AT BOTTOM OF LEAD AND IS COINCIDENT WITH THE LEAD WHERE THE LEAD EXITS THE PLASTIC BODY AT THE BOTTOM OF THE PARTING LINE.
 4. DATUMS -T-, -U- AND -Z- TO BE DETERMINED AT DATUM PLANE -AB-.
 5. DIMENSIONS S AND V TO BE DETERMINED AT SEATING PLANE -AC-.
 6. DIMENSIONS A AND B DO NOT INCLUDE MOLD PROTRUSION. ALLOWABLE PROTRUSION IS 0.25 (0.010) PER SIDE. DIMENSIONS A AND B DO INCLUDE MOLD MISMATCH AND ARE DETERMINED AT DATUM PLANE -AB-.
 7. DIMENSION D DOES NOT INCLUDE DAMBAR PROTRUSION. DAMBAR PROTRUSION SHALL NOT CAUSE THE D DIMENSION TO EXCEED 0.530 (0.021).

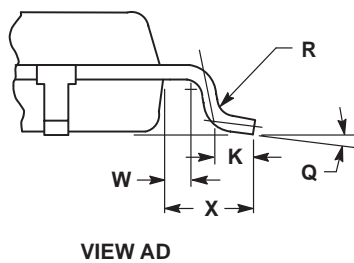
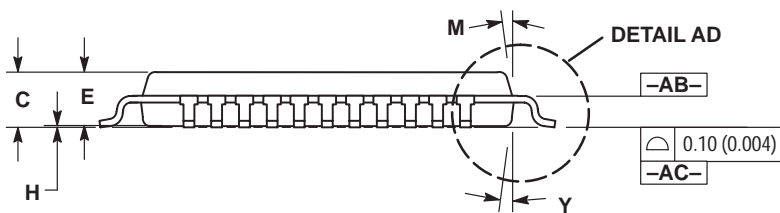

| DIM | MILLIMETERS | | INCHES | |
|-----|-------------|--------|-----------|-------|
| | MIN | MAX | MIN | MAX |
| A | 9.950 | 10.050 | 0.392 | 0.396 |
| B | 9.950 | 10.050 | 0.392 | 0.396 |
| C | 1.400 | 1.600 | 0.055 | 0.063 |
| D | 0.300 | 0.450 | 0.012 | 0.018 |
| E | 1.350 | 1.450 | 0.053 | 0.057 |
| F | 0.300 | 0.400 | 0.012 | 0.016 |
| G | 0.800 BSC | | 0.031 BSC | |
| H | 0.050 | 0.150 | 0.002 | 0.006 |
| J | 0.090 | 0.200 | 0.004 | 0.008 |
| K | 0.450 | 0.550 | 0.018 | 0.022 |
| L | 8.000 BSC | | 0.315 BSC | |
| M | 12° REF | | 12° REF | |
| N | 0.090 | 0.160 | 0.004 | 0.006 |
| Q | 1° | 5° | 1° | 5° |
| R | 0.100 | 0.200 | 0.004 | 0.008 |
| S | 11.900 | 12.100 | 0.469 | 0.476 |
| V | 11.900 | 12.100 | 0.469 | 0.476 |
| W | 0.200 REF | | 0.008 REF | |
| X | 1.000 REF | | 0.039 REF | |
| Y | 12° REF | | 12° REF | |

FB SUFFIX
CASE 824E-02
 Plastic Package
 (QFP)
 ISSUE A

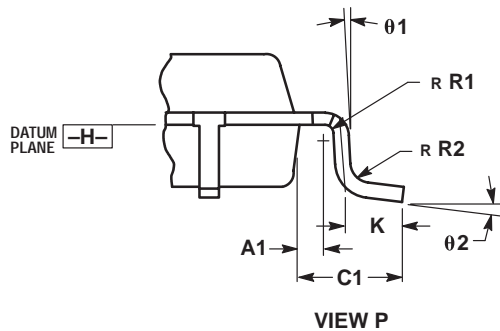
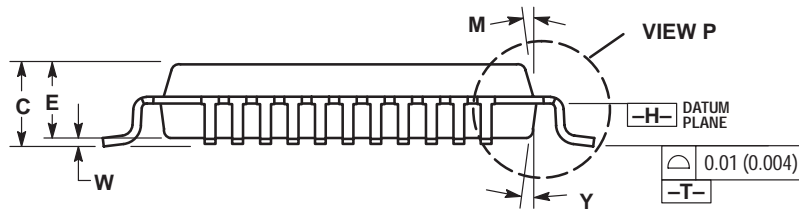
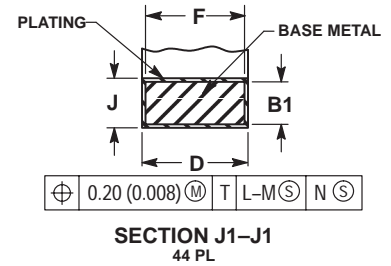
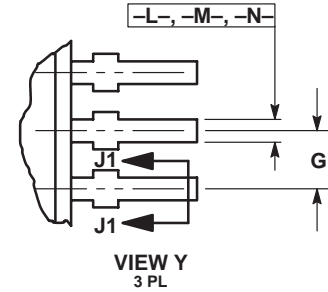
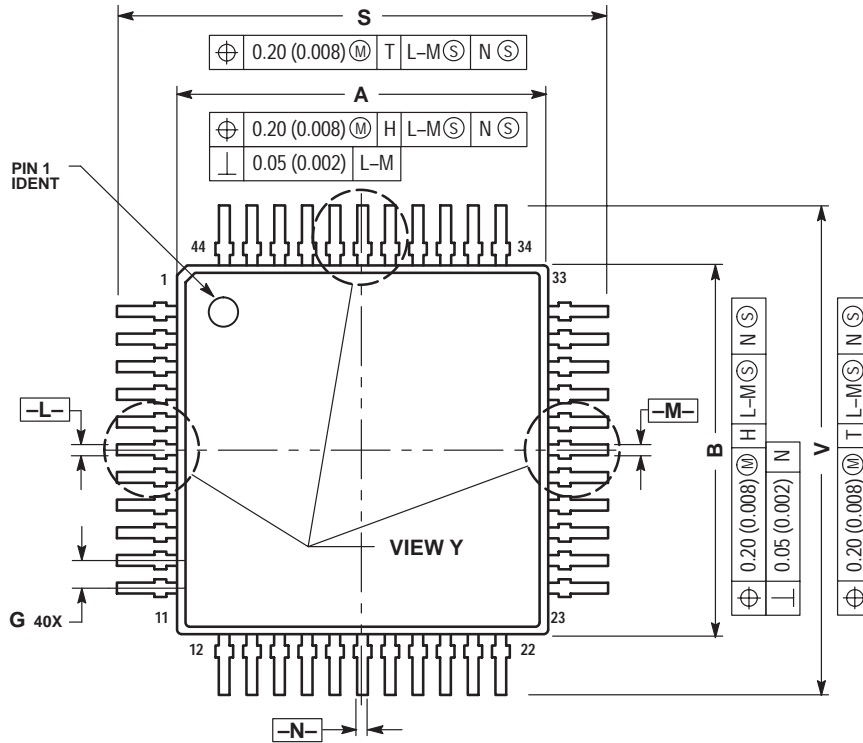
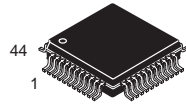

- NOTES:
1. DIMENSIONING AND TOLERANCING PER ANSI Y14.5M, 1982.
 2. CONTROLLING DIMENSION: MILLIMETER.
 3. DATUM PLANE -H- IS LOCATED AT BOTTOM OF LEAD AND IS COINCIDENT WITH THE LEAD WHERE THE LEAD EXITS THE PLASTIC BODY AT THE BOTTOM OF THE PARTING LINE.
 4. DATUMS -L-, -M- AND -N- TO BE DETERMINED AT DATUM PLANE -H-.
 5. DIMENSIONS S AND V TO BE DETERMINED AT SEATING PLANE -T-.
 6. DIMENSIONS A AND B DO NOT INCLUDE MOLD PROTRUSION. ALLOWABLE PROTRUSION IS 0.25 (0.010) PER SIDE. DIMENSIONS A AND B DO INCLUDE MOLD MISMATCH AND ARE DETERMINED AT DATUM PLANE -H-.
 7. DIMENSION D DOES NOT INCLUDE DAMBAR PROTRUSION. DAMBAR PROTRUSION SHALL NOT CAUSE THE D DIMENSION TO EXCEED 0.530 (0.021).

| DIM | MILLIMETERS | | INCHES | |
|------------|-------------|-------|-----------|--------|
| | MIN | MAX | MIN | MAX |
| A | 9.90 | 10.10 | 0.390 | 0.398 |
| B | 9.90 | 10.10 | 0.390 | 0.398 |
| C | 2.00 | 2.21 | 0.079 | 0.087 |
| D | 0.30 | 0.45 | 0.0118 | 0.0177 |
| E | 2.00 | 2.10 | 0.079 | 0.083 |
| F | 0.30 | 0.40 | 0.012 | 0.016 |
| G | 0.80 BSC | | 0.031 BSC | |
| J | 0.13 | 0.23 | 0.005 | 0.009 |
| K | 0.65 | 0.95 | 0.026 | 0.037 |
| M | 5° 10° | | 5° 10° | |
| S | 12.95 | 13.45 | 0.510 | 0.530 |
| V | 12.95 | 13.45 | 0.510 | 0.530 |
| W | 0.000 | 0.210 | 0.000 | 0.008 |
| Y | 5° 10° | | 5° 10° | |
| A1 | 0.450 REF | | 0.018 REF | |
| B1 | 0.130 | 0.170 | 0.005 | 0.007 |
| C1 | 1.600 REF | | 0.063 REF | |
| R1 | 0.130 | 0.300 | 0.005 | 0.012 |
| R2 | 0.130 | 0.300 | 0.005 | 0.012 |
| $\theta 1$ | 5° 10° | | 5° 10° | |
| $\theta 2$ | 0° 7° | | 0° 7° | |

FB SUFFIX
CASE 840F-01
Plastic Package
ISSUE O

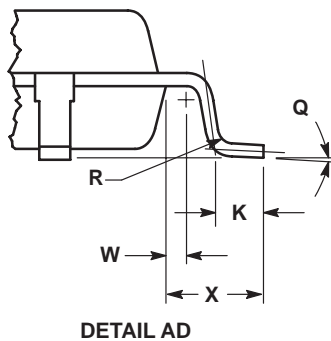
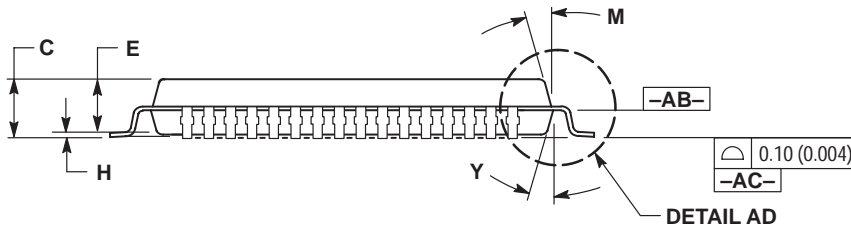
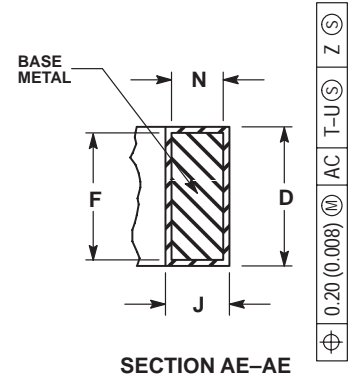
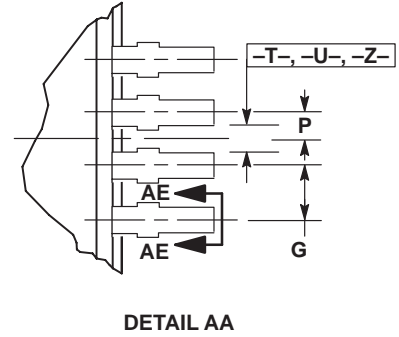
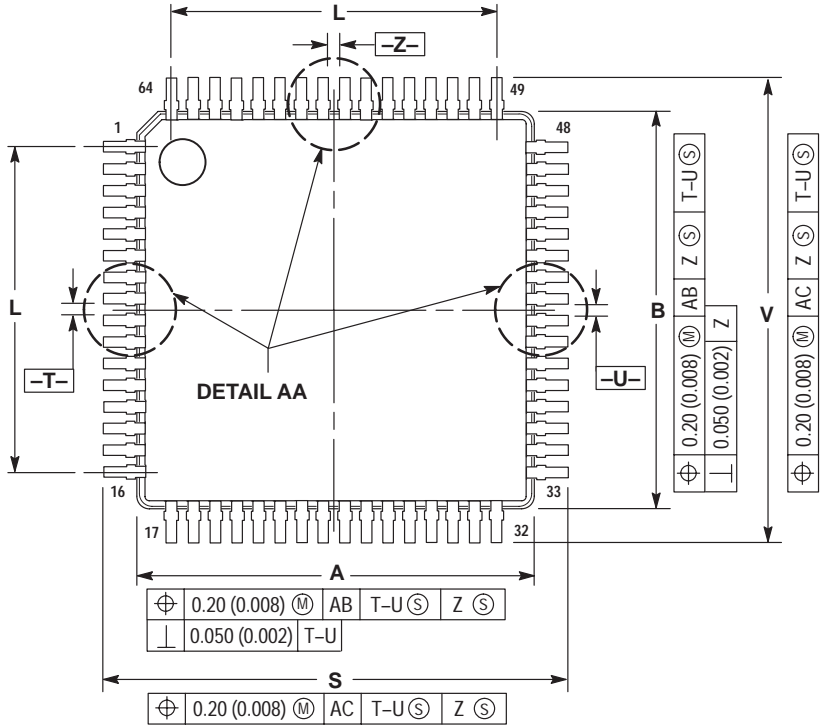
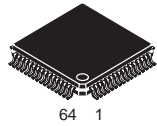

- NOTES:
1. DIMENSIONING AND TOLERANCING PER ANSI Y14.5M, 1982.
 2. CONTROLLING DIMENSION: MILLIMETER.
 3. DATUM PLANE -AB- IS LOCATED AT BOTTOM OF LEAD AND IS COINCIDENT WITH THE LEAD WHERE THE LEAD EXITS THE PLASTIC BODY AT THE BOTTOM OF THE PARTING LINE.
 4. DATUMS -T-, -U- AND -Z- TO BE DETERMINED AT DATUM PLANE -AC-.
 5. DIMENSIONS S AND V TO BE DETERMINED AT SEATING PLANE -AC-.
 6. DIMENSIONS A AND B DO NOT INCLUDE MOLD PROTRUSION. ALLOWABLE PROTRUSION IS 0.25 (0.010) PER SIDE. DIMENSIONS A AND B DO INCLUDE MOLD MISMATCH AND ARE DETERMINED AT DATUM PLANE -AB-.
 7. DIMENSION D DOES NOT INCLUDE DAMBAR PROTRUSION. DAMBAR PROTRUSION SHALL NOT CAUSE THE D DIMENSION TO EXCEED 0.350 (0.014).

| DIM | MILLIMETERS | | INCHES | |
|-----|-------------|--------|-----------|-------|
| | MIN | MAX | MIN | MAX |
| A | 9.950 | 10.050 | 0.392 | 0.396 |
| B | 9.950 | 10.050 | 0.392 | 0.396 |
| C | 1.400 | 1.600 | 0.055 | 0.063 |
| D | 0.170 | 0.270 | 0.007 | 0.011 |
| E | 1.350 | 1.450 | 0.053 | 0.057 |
| F | 0.170 | 0.230 | 0.007 | 0.009 |
| G | 0.500 BSC | | 0.020 BSC | |
| H | 0.050 | 0.150 | 0.002 | 0.006 |
| J | 0.090 | 0.200 | 0.004 | 0.008 |
| K | 0.450 | 0.550 | 0.018 | 0.022 |
| L | 7.500 BSC | | 0.295 BSC | |
| M | 12° REF | | 12° REF | |
| N | 0.090 | 0.160 | 0.004 | 0.006 |
| P | 0.250 BSC | | 0.010 BSC | |
| Q | 1° | 5° | 1° | 5° |
| R | 0.100 | 0.200 | 0.004 | 0.008 |
| S | 11.900 | 12.100 | 0.469 | 0.476 |
| V | 11.900 | 12.100 | 0.469 | 0.476 |
| W | 0.200 REF | | 0.008 REF | |
| X | 1.000 REF | | 0.039 REF | |
| Y | 12° REF | | 12° REF | |

DM SUFFIX
CASE 846A-02
 Plastic Package
 (Micro-8)
 ISSUE C

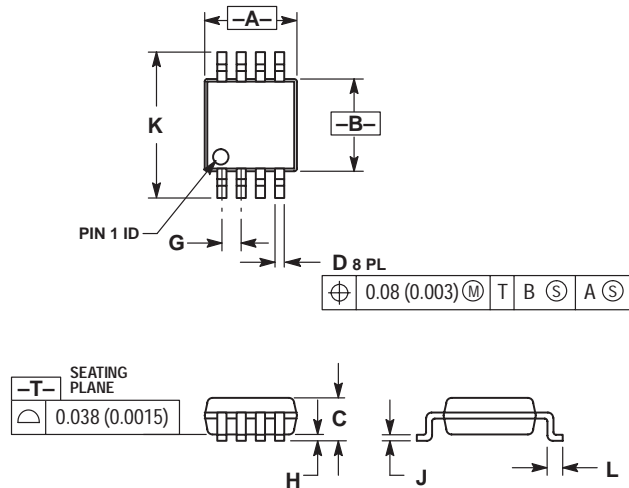

NOTES:

1. DIMENSIONING AND TOLERANCING PER ANSI Y14.5M, 1982.
2. CONTROLLING DIMENSION: MILLIMETER.
3. DIMENSION A DOES NOT INCLUDE MOLD FLASH, PROTRUSIONS OR GATE BURRS. MOLD FLASH, PROTRUSIONS OR GATE BURRS SHALL NOT EXCEED 0.15 (0.006) PER SIDE.
4. DIMENSION B DOES NOT INCLUDE INTERLEAD FLASH OR PROTRUSION. INTERLEAD FLASH OR PROTRUSION SHALL NOT EXCEED 0.25 (0.010) PER SIDE.

| DIM | MILLIMETERS | | INCHES | |
|-----|-------------|------|-----------|-------|
| | MIN | MAX | MIN | MAX |
| A | 2.90 | 3.10 | 0.114 | 0.122 |
| B | 2.90 | 3.10 | 0.114 | 0.122 |
| C | --- | 1.10 | --- | 0.043 |
| D | 0.25 | 0.40 | 0.010 | 0.016 |
| G | 0.65 BSC | | 0.026 BSC | |
| H | 0.05 | 0.15 | 0.002 | 0.006 |
| J | 0.13 | 0.23 | 0.005 | 0.009 |
| K | 4.75 | 5.05 | 0.187 | 0.199 |
| L | 0.40 | 0.70 | 0.016 | 0.028 |

FB SUFFIX
CASE 848B-04
 Plastic Package
 (TQFP-52)
 ISSUE C

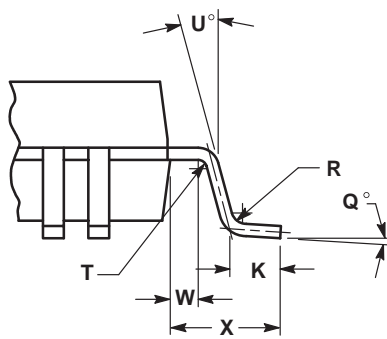
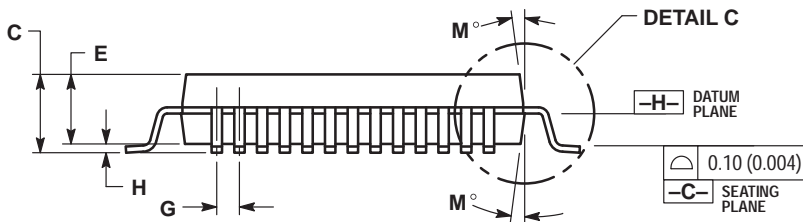
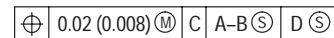
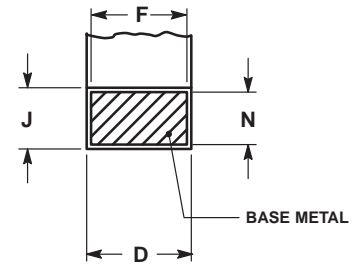
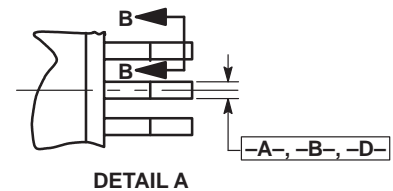
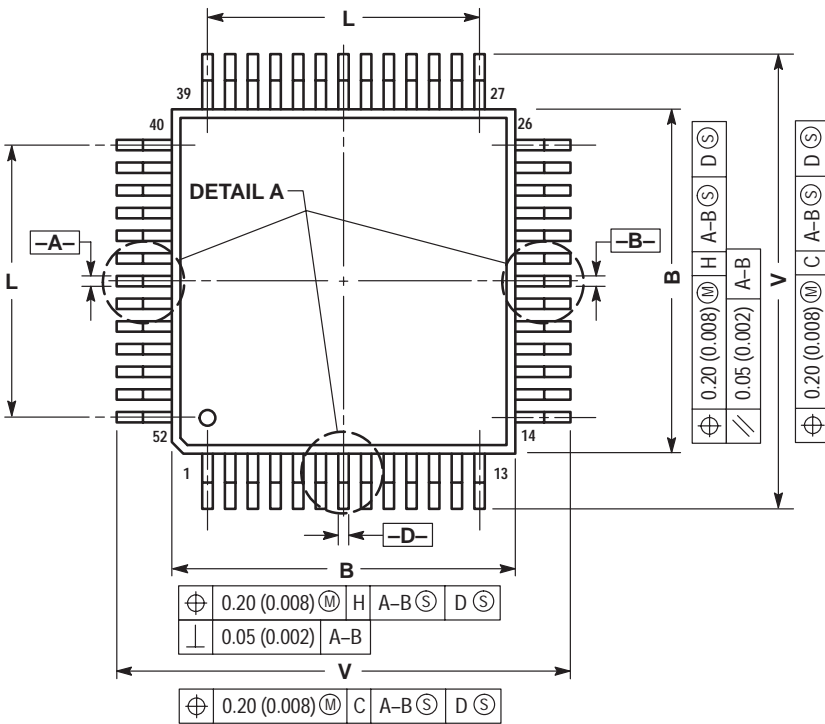
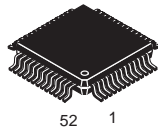

- NOTES:
- DIMENSIONING AND TOLERANCING PER ANSI Y14.5M, 1982.
 - CONTROLLING DIMENSION: MILLIMETER.
 - DATUM PLANE -H- IS LOCATED AT BOTTOM OF LEAD AND IS COINCIDENT WITH THE LEAD WHERE THE LEAD EXITS THE PLASTIC BODY AT THE BOTTOM OF THE PARTING LINE.
 - DATUMS -A-, -B- AND -D- TO BE DETERMINED AT DATUM PLANE -H-.
 - DIMENSIONS S AND V TO BE DETERMINED AT SEATING PLANE -C-.
 - DIMENSIONS A AND B DO NOT INCLUDE MOLD PROTRUSION. ALLOWABLE PROTRUSION IS 0.25 (0.010) PER SIDE. DIMENSIONS A AND B DO INCLUDE MOLD MISMATCH AND ARE DETERMINED AT DATUM PLANE -H-.
 - DIMENSION D DOES NOT INCLUDE DAMBAR PROTRUSION. ALLOWABLE DAMBAR PROTRUSION SHALL BE 0.08 (0.003) TOTAL IN EXCESS OF THE D DIMENSION AT MAXIMUM MATERIAL CONDITION. DAMBAR CANNOT BE LOCATED ON THE LOWER RADIUS OR THE FOOT.

| DIM | MILLIMETERS | | INCHES | |
|-----|-------------|-------|-----------|-------|
| | MIN | MAX | MIN | MAX |
| A | 9.90 | 10.10 | 0.390 | 0.398 |
| B | 9.90 | 10.10 | 0.390 | 0.398 |
| C | 2.10 | 2.45 | 0.083 | 0.096 |
| D | 0.22 | 0.38 | 0.009 | 0.015 |
| E | 2.00 | 2.10 | 0.079 | 0.083 |
| F | 0.22 | 0.33 | 0.009 | 0.013 |
| G | 0.65 BSC | | 0.026 BSC | |
| H | --- | | 0.25 | 0.010 |
| J | 0.13 | 0.23 | 0.005 | 0.009 |
| K | 0.65 | 0.95 | 0.026 | 0.037 |
| L | 7.80 REF | | 0.307 REF | |
| M | 5° | 10° | 5° | 10° |
| N | 0.13 | 0.17 | 0.005 | 0.007 |
| Q | 0° | 7° | 0° | 7° |
| R | 0.13 | 0.30 | 0.005 | 0.012 |
| S | 12.95 | 13.45 | 0.510 | 0.530 |
| T | 0.13 | --- | 0.005 | --- |
| U | 0° | --- | 0° | --- |
| V | 12.95 | 13.45 | 0.510 | 0.530 |
| W | 0.35 | 0.45 | 0.014 | 0.018 |
| X | 1.6 REF | | 0.063 REF | |

FB SUFFIX
CASE 848D-03
 Plastic Package
 ISSUE C

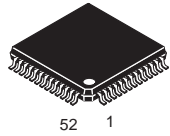

52 1

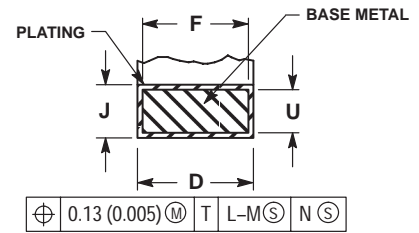
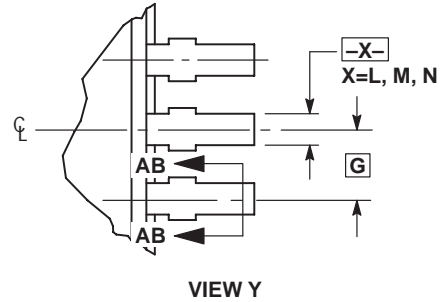
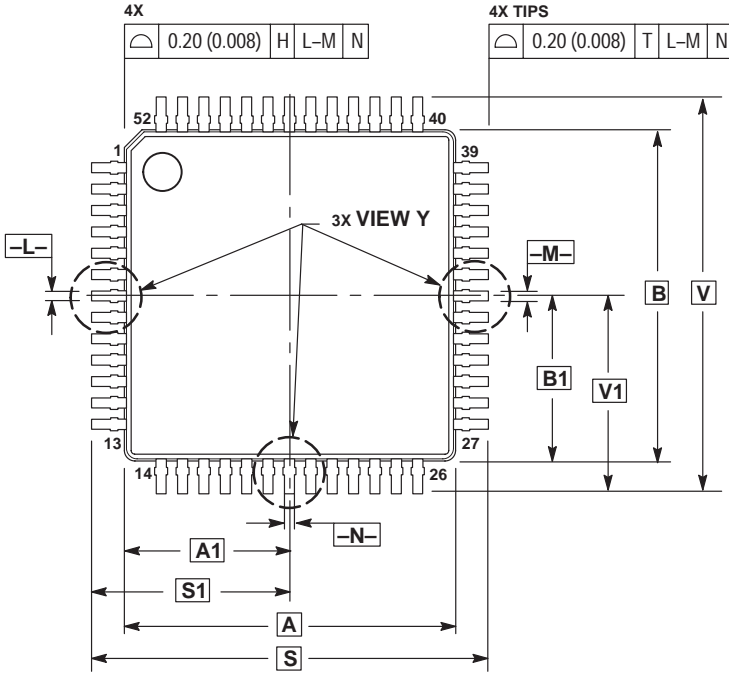

SECTION AB-AB
 ROTATED 90° CLOCKWISE

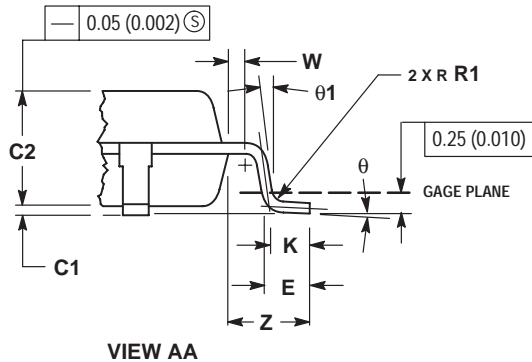
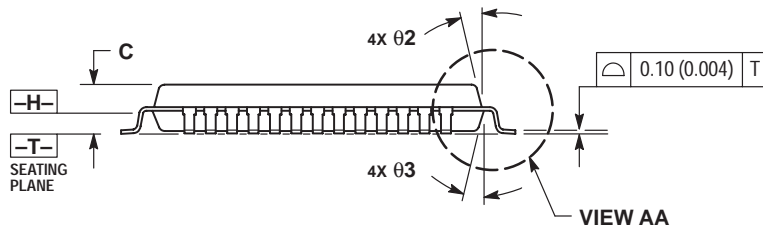

- NOTES:**
1. DIMENSIONING AND TOLERANCING PER ANSI Y14.5M, 1982.
 2. CONTROLLING DIMENSION: MILLIMETER.
 3. DATUM PLANE -H- IS LOCATED AT BOTTOM OF LEAD AND IS COINCIDENT WITH THE LEAD WHERE THE LEAD EXITS THE PLASTIC BODY AT THE BOTTOM OF THE PARTING LINE.
 4. DATUMS -L-, -M- AND -N- TO BE DETERMINED AT DATUM PLANE -H-.
 5. DIMENSIONS S AND V TO BE DETERMINED AT SEATING PLANE -T-.
 6. DIMENSIONS A AND B DO NOT INCLUDE MOLD PROTRUSION. ALLOWABLE PROTRUSION IS 0.25 (0.010) PER SIDE. DIMENSIONS A AND B DO NOT INCLUDE MOLD MISMATCH AND ARE DETERMINED AT DATUM PLANE -H-.
 7. DIMENSION D DOES NOT INCLUDE DAMBAR PROTRUSION. DAMBAR PROTRUSION SHALL NOT CAUSE THE LEAD WIDTH TO EXCEED 0.46 (0.018). MINIMUM SPACE BETWEEN PROTRUSION AND ADJACENT LEAD OR PROTRUSION 0.07 (0.003).

| DIM | MILLIMETERS | | INCHES | |
|---------|-------------|-----------|--------|-------|
| | MIN | MAX | MIN | MAX |
| A | 10.00 BSC | 0.394 BSC | | |
| A1 | 5.00 BSC | 0.197 BSC | | |
| B | 10.00 BSC | 0.394 BSC | | |
| B1 | 5.00 BSC | 0.197 BSC | | |
| C | --- | 1.70 | --- | 0.067 |
| C1 | 0.05 | 0.20 | 0.002 | 0.008 |
| C2 | 1.30 | 1.50 | 0.051 | 0.059 |
| D | 0.20 | 0.40 | 0.008 | 0.016 |
| E | 0.45 | 0.75 | 0.018 | 0.030 |
| F | 0.22 | 0.35 | 0.009 | 0.014 |
| G | 0.65 BSC | 0.026 BSC | | |
| J | 0.07 | 0.20 | 0.003 | 0.008 |
| K | 0.50 REF | 0.020 REF | | |
| R1 | 0.08 | 0.20 | 0.003 | 0.008 |
| S | 12.00 BSC | 0.472 BSC | | |
| S1 | 6.00 BSC | 0.236 BSC | | |
| U | 0.09 | 0.16 | 0.004 | 0.006 |
| V | 12.00 BSC | 0.472 BSC | | |
| V1 | 6.00 BSC | 0.236 BSC | | |
| W | 0.20 REF | 0.008 REF | | |
| Z | 1.00 REF | 0.039 REF | | |
| theta | 0° | 7° | 0° | 7° |
| theta 1 | 0° | --- | 0° | --- |
| theta 2 | 12° REF | 12° REF | | |
| theta 3 | 5° | 13° | 5° | 13° |

B SUFFIX
CASE 858-01
 Plastic Package
 ISSUE O

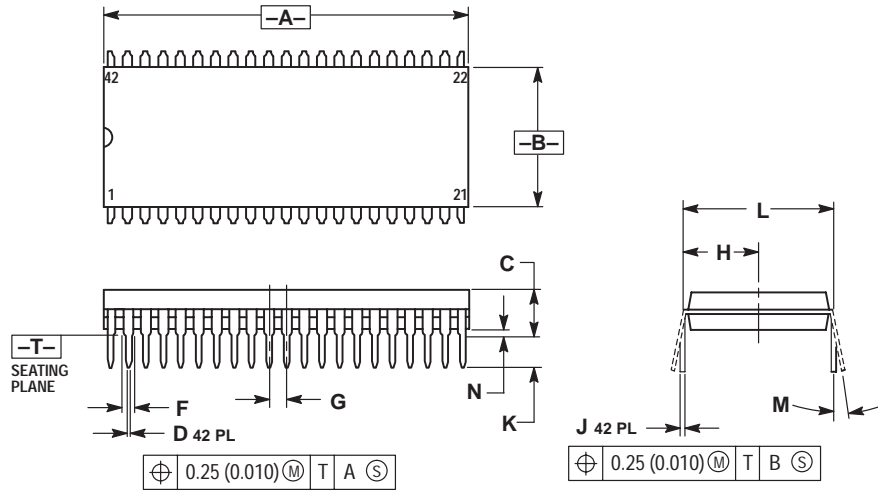
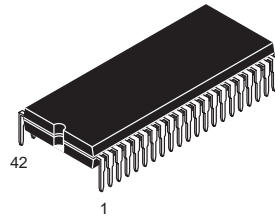

NOTES:

1. DIMENSIONING AND TOLERANCING PER ANSI Y14.5M, 1982.
2. CONTROLLING DIMENSION: INCH.
3. DIMENSION L TO CENTER OF LEAD WHEN FORMED PARALLEL.
4. DIMENSIONS A AND B DO NOT INCLUDE MOLD FLASH. MAXIMUM MOLD FLASH 0.25 (0.010).

| DIM | INCHES | | MILLIMETERS | |
|-----|-----------|-------|-------------|-------|
| | MIN | MAX | MIN | MAX |
| A | 1.435 | 1.465 | 36.45 | 37.21 |
| B | 0.540 | 0.560 | 13.72 | 14.22 |
| C | 0.155 | 0.200 | 3.94 | 5.08 |
| D | 0.014 | 0.022 | 0.36 | 0.56 |
| F | 0.032 | 0.046 | 0.81 | 1.17 |
| G | 0.070 BSC | | 1.778 BSC | |
| H | 0.300 BSC | | 7.62 BSC | |
| J | 0.008 | 0.015 | 0.20 | 0.38 |
| K | 0.115 | 0.135 | 2.92 | 3.43 |
| L | 0.600 BSC | | 15.24 BSC | |
| M | 0° | 15° | 0° | 15° |
| N | 0.020 | 0.040 | 0.51 | 1.02 |

B SUFFIX
CASE 859-01
 Plastic Package
 (SDIP)
 ISSUE O

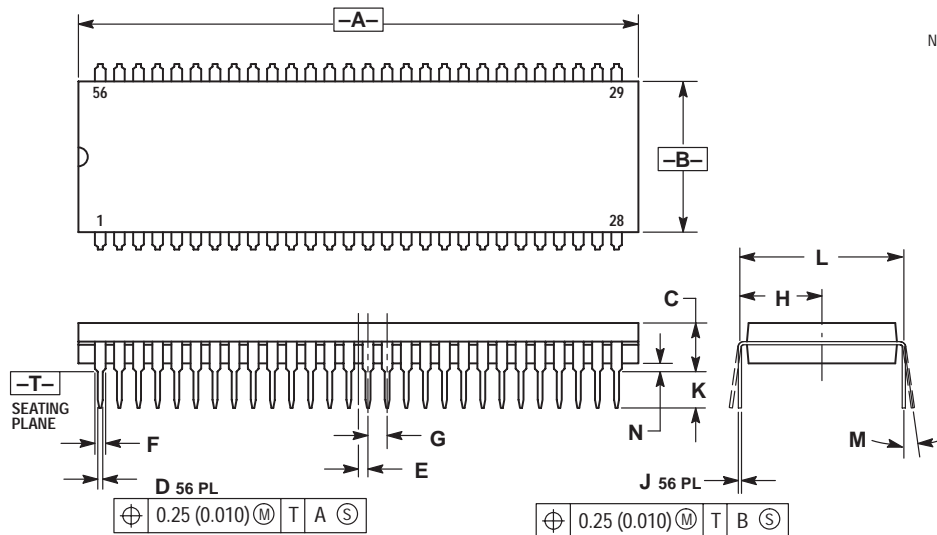
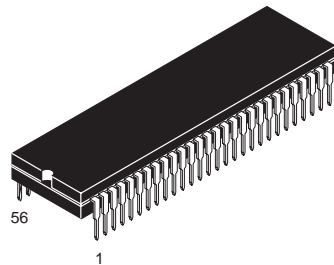

NOTES:

1. DIMENSIONING AND TOLERANCING PER ANSI Y14.5M, 1982.
2. CONTROLLING DIMENSION: INCH.
3. DIMENSION L TO CENTER OF LEAD WHEN FORMED PARALLEL.
4. DIMENSIONS A AND B DO NOT INCLUDE MOLD FLASH. MAXIMUM MOLD FLASH 0.25 (0.010)

| DIM | INCHES | | MILLIMETERS | |
|-----|-----------|-------|-------------|-------|
| | MIN | MAX | MIN | MAX |
| A | 2.035 | 2.065 | 51.69 | 52.45 |
| B | 0.540 | 0.560 | 13.72 | 14.22 |
| C | 0.155 | 0.200 | 3.94 | 5.08 |
| D | 0.014 | 0.022 | 0.36 | 0.56 |
| E | 0.035 BSC | | 0.89 BSC | |
| F | 0.032 | 0.046 | 0.81 | 1.17 |
| G | 0.070 BSC | | 1.778 BSC | |
| H | 0.300 BSC | | 7.62 BSC | |
| J | 0.008 | 0.015 | 0.20 | 0.38 |
| K | 0.115 | 0.135 | 2.92 | 3.43 |
| L | 0.600 BSC | | 15.24 BSC | |
| M | 0° | 15° | 0° | 15° |
| N | 0.020 | 0.040 | 0.51 | 1.02 |

FB, FTB SUFFIX
CASE 873-01
 Plastic Package
 (TQFP-32)
 ISSUE A

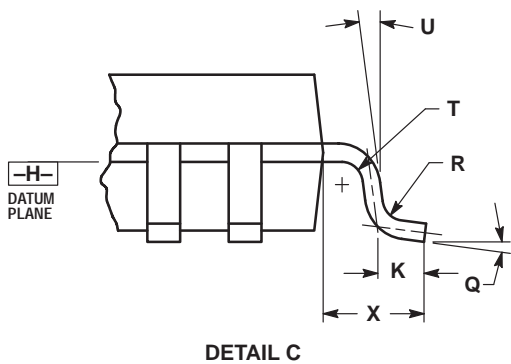
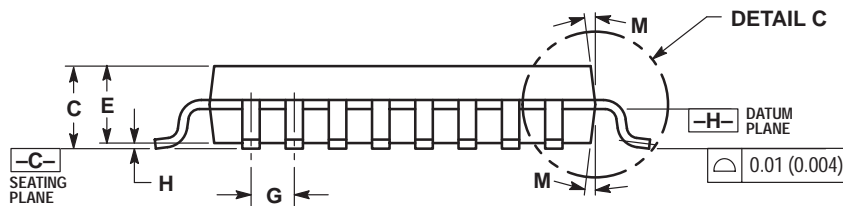
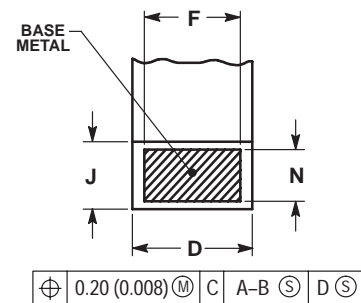
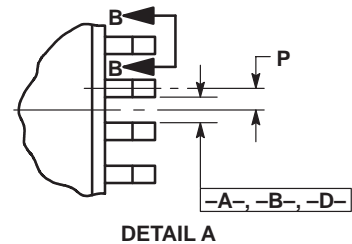
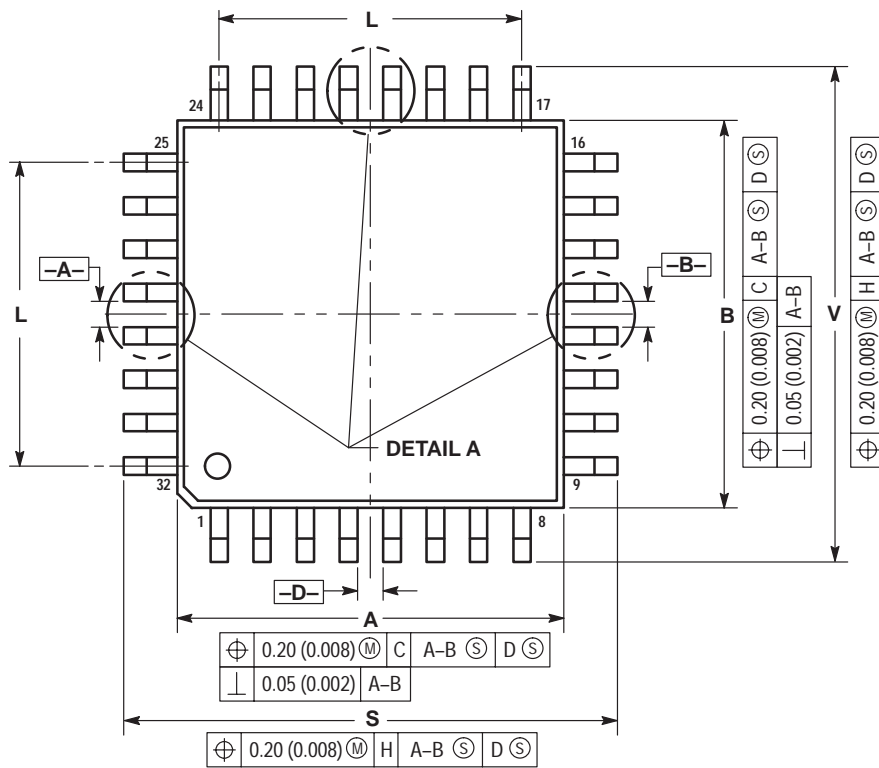
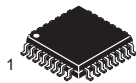

NOTES:

1. DIMENSION AND TOLERANCING PER ANSI Y14.5M, 1982.
2. CONTROLLING DIMENSION: MILLIMETER.
3. DATUM PLANE -H- IS LOCATED AT BOTTOM OF LEAD AND IS COINCIDENT WITH THE LEAD WHERE THE LEAD EXITS THE PLASTIC BODY AT THE BOTTOM OF THE PARTING LINE.
4. DATUMS -A-, -B- AND -D- TO BE DETERMINED AT DATUM PLANE -H-.
5. DIMENSIONS S AND V TO BE DETERMINED AT SEATING PLANE -C-.
6. DIMENSIONS A AND B DO NOT INCLUDE MOLD PROTRUSION. ALLOWABLE PROTRUSION IS 0.25 (0.010) PER SIDE. DIMENSIONS A AND B DO INCLUDE MOLD MISMATCH AND ARE DETERMINED AT DATUM PLANE -H-.
7. DIMENSION D DOES NOT INCLUDE DAMBAR PROTRUSION. ALLOWABLE DAMBAR PROTRUSION SHALL BE 0.08 (0.003) TOTAL IN EXCESS OF THE D DIMENSION AT MAXIMUM MATERIAL CONDITION. DAMBAR CANNOT BE LOCATED ON THE LOWER RADIUS OR THE FOOT.

| DIM | MILLIMETERS | | INCHES | |
|-----|-------------|-------|--------|-------|
| | MIN | MAX | MIN | MAX |
| A | 6.95 | 7.10 | 0.274 | 0.280 |
| B | 6.95 | 7.10 | 0.274 | 0.280 |
| C | 1.40 | 1.60 | 0.055 | 0.063 |
| D | 0.273 | 0.373 | 0.010 | 0.015 |
| E | 1.30 | 1.50 | 0.051 | 0.059 |
| F | 0.273 | --- | 0.010 | --- |
| G | 0.80 | BSC | 0.031 | BSC |
| H | --- | 0.20 | --- | 0.008 |
| J | 0.119 | 0.197 | 0.005 | 0.008 |
| K | 0.33 | 0.57 | 0.013 | 0.022 |
| L | 5.6 | REF | 0.220 | REF |
| M | 6° | 8° | 6° | 8° |
| N | 0.119 | 0.135 | 0.005 | 0.005 |
| P | 0.40 | BSC | 0.016 | BSC |
| Q | 5° | 10° | 5° | 10° |
| R | 0.15 | 0.25 | 0.006 | 0.010 |
| S | 8.85 | 9.15 | 0.348 | 0.360 |
| T | 0.15 | 0.25 | 0.006 | 0.010 |
| U | 5° | 11° | 5° | 11° |
| V | 8.85 | 9.15 | 0.348 | 0.360 |
| X | 1.00 | REF | 0.039 | REF |

T SUFFIX
CASE 894-03
 Plastic Package
 (23-Pin SZIP)
 ISSUE B

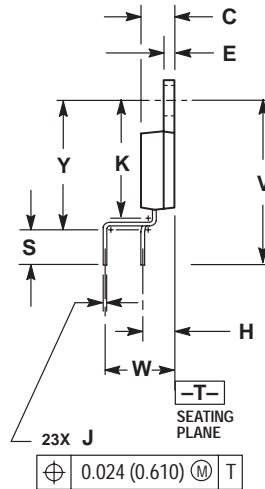
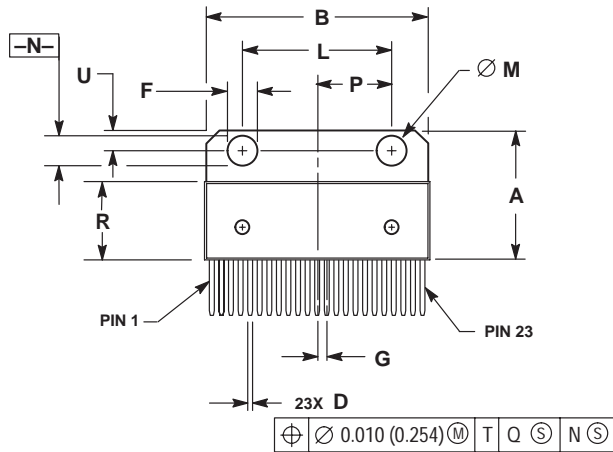
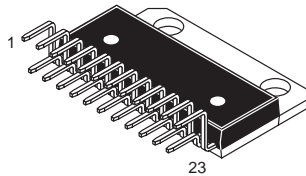

NOTES:

1. DIMENSIONING AND TOLERANCING PER ANSI Y14.5M, 1982.
2. CONTROLLING DIMENSION: INCH.
3. DIMENSION R DOES NOT INCLUDE MOLD FLASH OR PROTRUSIONS.
4. DIMENSION B DOES NOT INCLUDE MOLD FLASH OR PROTRUSIONS.
5. MOLD FLASH OR PROTRUSIONS SHALL NOT EXCEED 0.010 (0.250).
6. DIMENSION D DOES NOT INCLUDE DAMBAR PROTRUSION. ALLOWABLE PROTRUSION SHALL BE 0.003 (0.076) TOTAL IN EXCESS OF THE D DIMENSION AT MAXIMUM MATERIAL CONDITION.

| DIM | INCHES | | MILLIMETERS | |
|-----|-----------|-------|-------------|--------|
| | MIN | MAX | MIN | MAX |
| A | 0.684 | 0.694 | 17.374 | 17.627 |
| B | 1.183 | 1.193 | 30.048 | 30.302 |
| C | 0.175 | 0.179 | 4.445 | 4.547 |
| D | 0.026 | 0.031 | 0.660 | 0.787 |
| E | 0.058 | 0.062 | 1.473 | 1.574 |
| F | 0.165 | 0.175 | 4.191 | 4.445 |
| G | 0.050 BSC | | 1.270 BSC | |
| H | 0.169 BSC | | 4.293 BSC | |
| J | 0.014 | 0.020 | 0.356 | 0.508 |
| K | 0.625 | 0.639 | 15.875 | 16.231 |
| L | 0.770 | 0.790 | 19.558 | 20.066 |
| M | 0.148 | 0.152 | 3.760 | 3.861 |
| N | 0.148 | 0.152 | 3.760 | 3.861 |
| P | 0.390 BSC | | 9.906 BSC | |
| R | 0.416 | 0.424 | 10.566 | 10.770 |
| S | 0.157 | 0.167 | 3.988 | 4.242 |
| U | 0.105 | 0.115 | 2.667 | 2.921 |
| V | 0.868 REF | | 22.047 REF | |
| W | 0.200 BSC | | 5.080 BSC | |
| Y | 0.700 | 0.710 | 17.780 | 18.034 |

FTA SUFFIX
CASE 932-02
Plastic Package
(TQFP-48)
ISSUE D

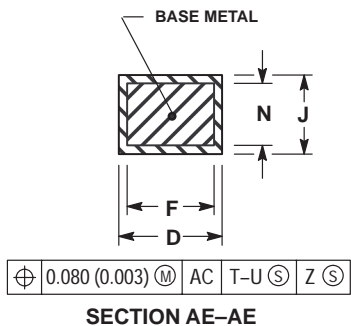
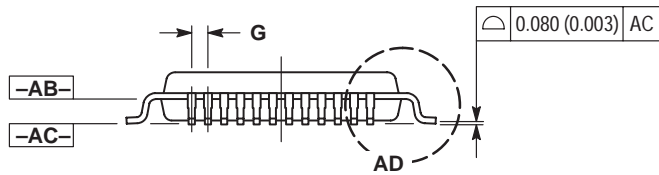
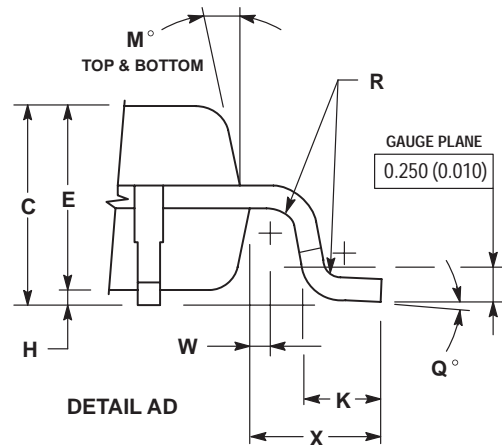
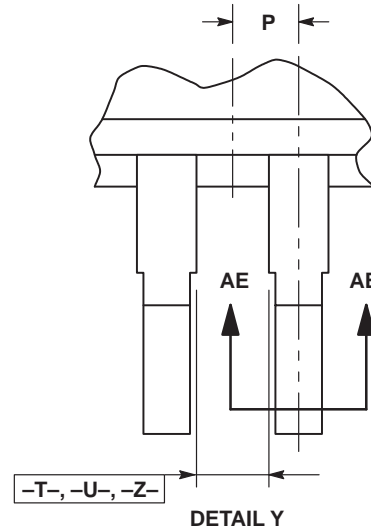
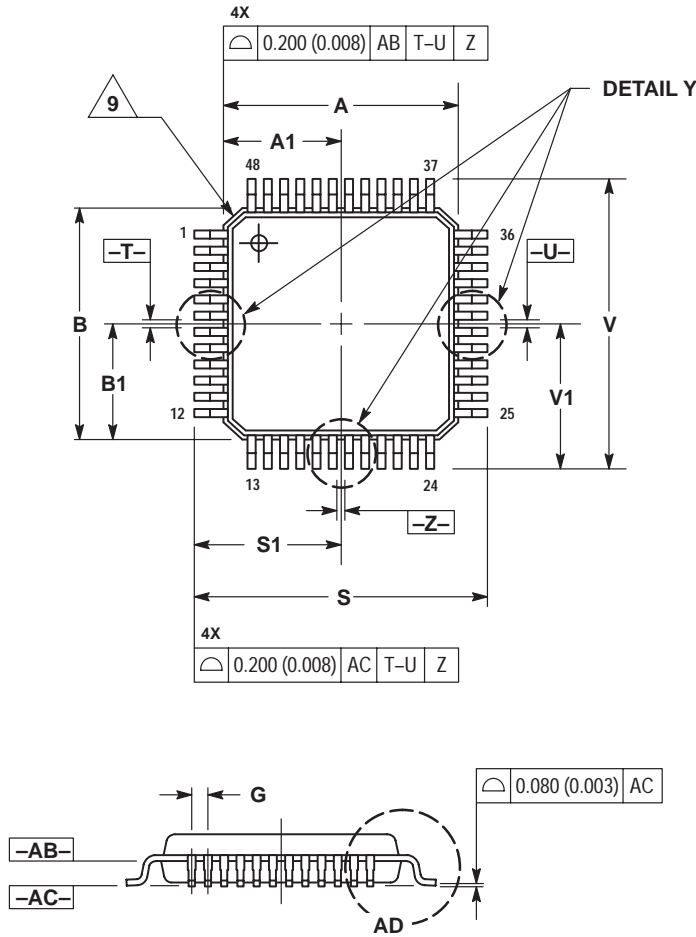
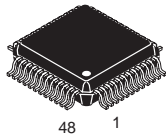

- NOTES:
1. DIMENSIONING AND TOLERANCING PER ANSI Y14.5M, 1982.
 2. CONTROLLING DIMENSION: MILLIMETER.
 3. DATUM PLANE -AB- IS LOCATED AT BOTTOM OF LEAD AND IS COINCIDENT WITH THE LEAD WHERE THE LEAD EXITS THE PLASTIC BODY AT THE BOTTOM OF THE PARTING LINE.
 4. DATUMS -T-, -U-, AND -Z- TO BE DETERMINED AT DATUM PLANE -AB-.
 5. DIMENSIONS S AND V TO BE DETERMINED AT SEATING PLANE -AC-.
 6. DIMENSIONS A AND B DO NOT INCLUDE MOLD PROTRUSION. ALLOWABLE PROTRUSION IS 0.250 (0.010) PER SIDE. DIMENSIONS A AND B DO INCLUDE MOLD MISMATCH AND ARE DETERMINED AT DATUM PLANE -AB-.
 7. DIMENSION D DOES NOT INCLUDE DAMBAR PROTRUSION. DAMBAR PROTRUSION SHALL NOT CAUSE THE D DIMENSION TO EXCEED 0.350 (0.014).
 8. MINIMUM SOLDER PLATE THICKNESS SHALL BE 0.0076 (0.0003).
 9. EXACT SHAPE OF EACH CORNER IS OPTIONAL.

| DIM | MILLIMETERS | | INCHES | |
|-----|-------------|-------|--------|-------|
| | MIN | MAX | MIN | MAX |
| A | 7.000 | BSC | 0.276 | BSC |
| A1 | 3.500 | BSC | 0.138 | BSC |
| B | 7.000 | BSC | 0.276 | BSC |
| B1 | 3.500 | BSC | 0.138 | BSC |
| C | 1.400 | 1.600 | 0.055 | 0.063 |
| D | 0.170 | 0.270 | 0.007 | 0.011 |
| E | 1.350 | 1.450 | 0.053 | 0.057 |
| F | 0.170 | 0.230 | 0.007 | 0.009 |
| G | 0.500 | BASIC | 0.020 | BASIC |
| H | 0.050 | 0.150 | 0.002 | 0.006 |
| J | 0.090 | 0.200 | 0.004 | 0.008 |
| K | 0.500 | 0.700 | 0.020 | 0.028 |
| M | 12° | REF | 12° | REF |
| N | 0.090 | 0.160 | 0.004 | 0.006 |
| P | 0.250 | BASIC | 0.010 | BASIC |
| Q | 1° | 5° | 1° | 5° |
| R | 0.150 | 0.250 | 0.006 | 0.010 |
| S | 9.000 | BSC | 0.354 | BSC |
| S1 | 4.500 | BSC | 0.177 | BSC |
| V | 9.000 | BSC | 0.354 | BSC |
| V1 | 4.500 | BSC | 0.177 | BSC |
| W | 0.200 | REF | 0.008 | REF |
| X | 1.000 | REF | 0.039 | REF |

D2T SUFFIX
CASE 936-03
 Plastic Package
 ISSUE B

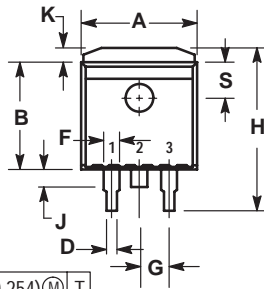
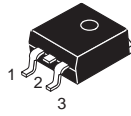

⊕ 0.010 (0.254) Ⓜ T

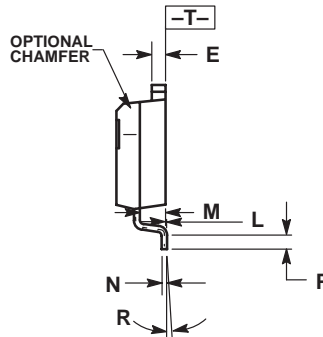
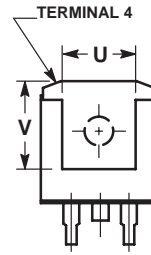
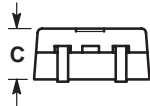

- NOTES:
1. DIMENSIONING AND TOLERANCING PER ANSI Y14.5M, 1982.
 2. CONTROLLING DIMENSION: INCH.
 3. TAB CONTOUR OPTIONAL WITHIN DIMENSIONS A AND K.
 4. DIMENSIONS U AND V ESTABLISH A MINIMUM MOUNTING SURFACE FOR TERMINAL 4.
 5. DIMENSIONS A AND B DO NOT INCLUDE MOLD FLASH OR GATE PROTRUSIONS. MOLD FLASH AND GATE PROTRUSIONS NOT TO EXCEED 0.025 (0.635) MAXIMUM.

| DIM | INCHES | | MILLIMETERS | |
|-----|-----------|-------|-------------|--------|
| | MIN | MAX | MIN | MAX |
| A | 0.386 | 0.403 | 9.804 | 10.236 |
| B | 0.356 | 0.368 | 9.042 | 9.347 |
| C | 0.170 | 0.180 | 4.318 | 4.572 |
| D | 0.026 | 0.036 | 0.660 | 0.914 |
| E | 0.045 | 0.055 | 1.143 | 1.397 |
| F | 0.051 REF | | 1.295 REF | |
| G | 0.100 BSC | | 2.540 BSC | |
| H | 0.539 | 0.579 | 13.691 | 14.707 |
| J | 0.125 MAX | | 3.175 MAX | |
| K | 0.050 REF | | 1.270 REF | |
| L | 0.000 | 0.010 | 0.000 | 0.254 |
| M | 0.088 | 0.102 | 2.235 | 2.591 |
| N | 0.018 | 0.026 | 0.457 | 0.660 |
| P | 0.058 | 0.078 | 1.473 | 1.981 |
| R | 5° REF | | 5° REF | |
| S | 0.116 REF | | 2.946 REF | |
| U | 0.200 MIN | | 5.080 MIN | |
| V | 0.250 MIN | | 6.350 MIN | |

D2T SUFFIX
CASE 936A-02
 Plastic Package
 (D²PAK)
 ISSUE A

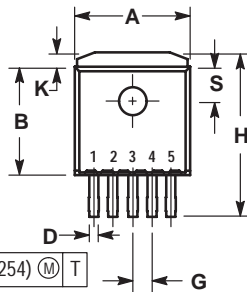
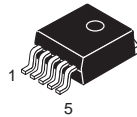

⊕ 0.010 (0.254) Ⓜ T

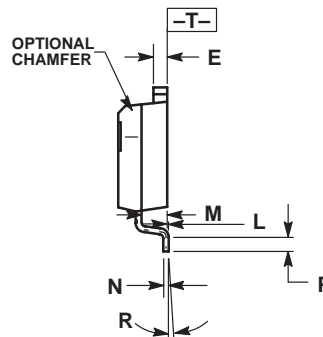
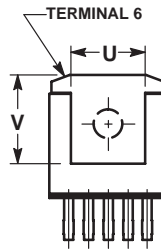
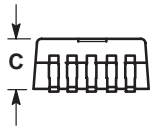

- NOTES:
1. DIMENSIONING AND TOLERANCING PER ANSI Y14.5M, 1982.
 2. CONTROLLING DIMENSION: INCH.
 3. TAB CONTOUR OPTIONAL WITHIN DIMENSIONS A AND K.
 4. DIMENSIONS U AND V ESTABLISH A MINIMUM MOUNTING SURFACE FOR TERMINAL 6.
 5. DIMENSIONS A AND B DO NOT INCLUDE MOLD FLASH OR GATE PROTRUSIONS. MOLD FLASH AND GATE PROTRUSIONS NOT TO EXCEED 0.025 (0.635) MAXIMUM.

| DIM | INCHES | | MILLIMETERS | |
|-----|-----------|-------|-------------|--------|
| | MIN | MAX | MIN | MAX |
| A | 0.386 | 0.403 | 9.804 | 10.236 |
| B | 0.356 | 0.368 | 9.042 | 9.347 |
| C | 0.170 | 0.180 | 4.318 | 4.572 |
| D | 0.026 | 0.036 | 0.660 | 0.914 |
| E | 0.045 | 0.055 | 1.143 | 1.397 |
| G | 0.067 BSC | | 1.702 BSC | |
| H | 0.539 | 0.579 | 13.691 | 14.707 |
| K | 0.050 REF | | 1.270 REF | |
| L | 0.000 | 0.010 | 0.000 | 0.254 |
| M | 0.088 | 0.102 | 2.235 | 2.591 |
| N | 0.018 | 0.026 | 0.457 | 0.660 |
| P | 0.058 | 0.078 | 1.473 | 1.981 |
| R | 5° REF | | 5° REF | |
| S | 0.116 REF | | 2.946 REF | |
| U | 0.200 MIN | | 5.080 MIN | |
| V | 0.250 MIN | | 6.350 MIN | |

DT, DTB SUFFIX
CASE 948E-02
 Plastic Package
 (TSSOP-20)
 ISSUE A

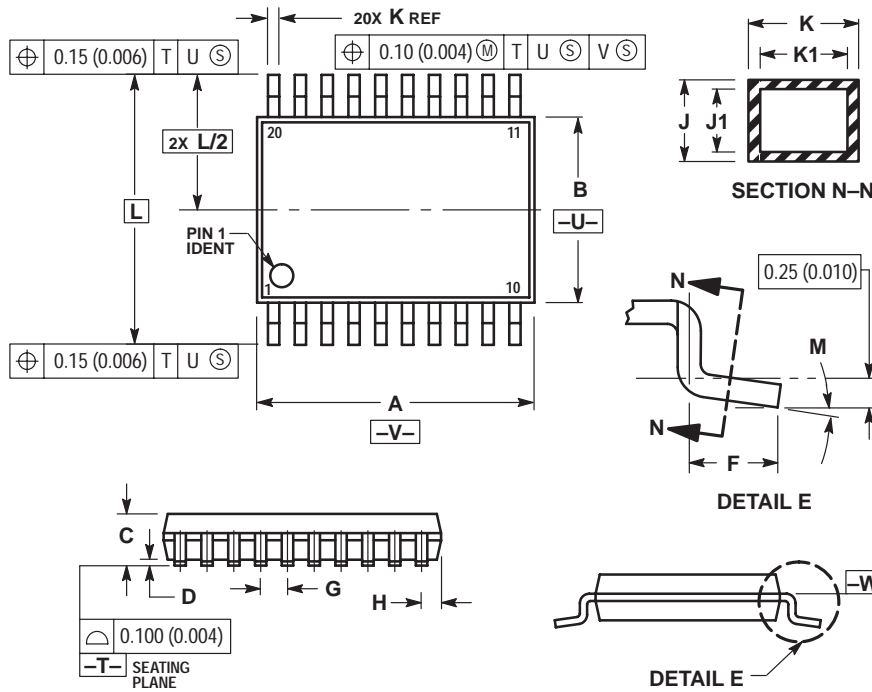
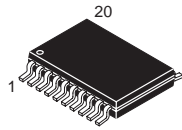

- NOTES:
1. DIMENSIONING AND TOLERANCING PER ANSI Y14.5M, 1982.
 2. CONTROLLING DIMENSION: MILLIMETER.
 3. DIMENSION A DOES NOT INCLUDE MOLD FLASH, PROTRUSIONS OR GATE BURRS. MOLD FLASH OR GATE BURRS SHALL NOT EXCEED 0.15 (0.006) PER SIDE.
 4. DIMENSION B DOES NOT INCLUDE INTERLEAD FLASH OR PROTRUSION. INTERLEAD FLASH OR PROTRUSION SHALL NOT EXCEED 0.25 (0.010) PER SIDE.
 5. DIMENSION K DOES NOT INCLUDE DAMBAR PROTRUSION. ALLOWABLE DAMBAR PROTRUSION SHALL BE 0.08 (0.003) TOTAL IN EXCESS OF THE K DIMENSION AT MAXIMUM MATERIAL CONDITION.
 6. TERMINAL NUMBERS ARE SHOWN FOR REFERENCE ONLY.
 7. DIMENSION A AND B ARE TO BE DETERMINED AT DATUM PLANE -W-.

| DIM | MILLIMETERS | | INCHES | |
|-----|-------------|------|-----------|-------|
| | MIN | MAX | MIN | MAX |
| A | 6.40 | 6.60 | 0.252 | 0.260 |
| B | 4.30 | 4.50 | 0.169 | 0.177 |
| C | --- | 1.20 | --- | 0.047 |
| D | 0.05 | 0.15 | 0.002 | 0.006 |
| F | 0.50 | 0.75 | 0.020 | 0.030 |
| G | 0.65 BSC | | 0.026 BSC | |
| H | 0.27 | 0.37 | 0.011 | 0.015 |
| J | 0.09 | 0.20 | 0.004 | 0.008 |
| J1 | 0.09 | 0.16 | 0.004 | 0.006 |
| K | 0.19 | 0.30 | 0.007 | 0.012 |
| K1 | 0.19 | 0.25 | 0.007 | 0.010 |
| L | 6.40 BSC | | 0.252 BSC | |
| M | 0° | 8° | 0° | 8° |

DTB SUFFIX
CASE 948F-01
 Plastic Package
 (TSSOP-16, TSSOP-16L)
 ISSUE O

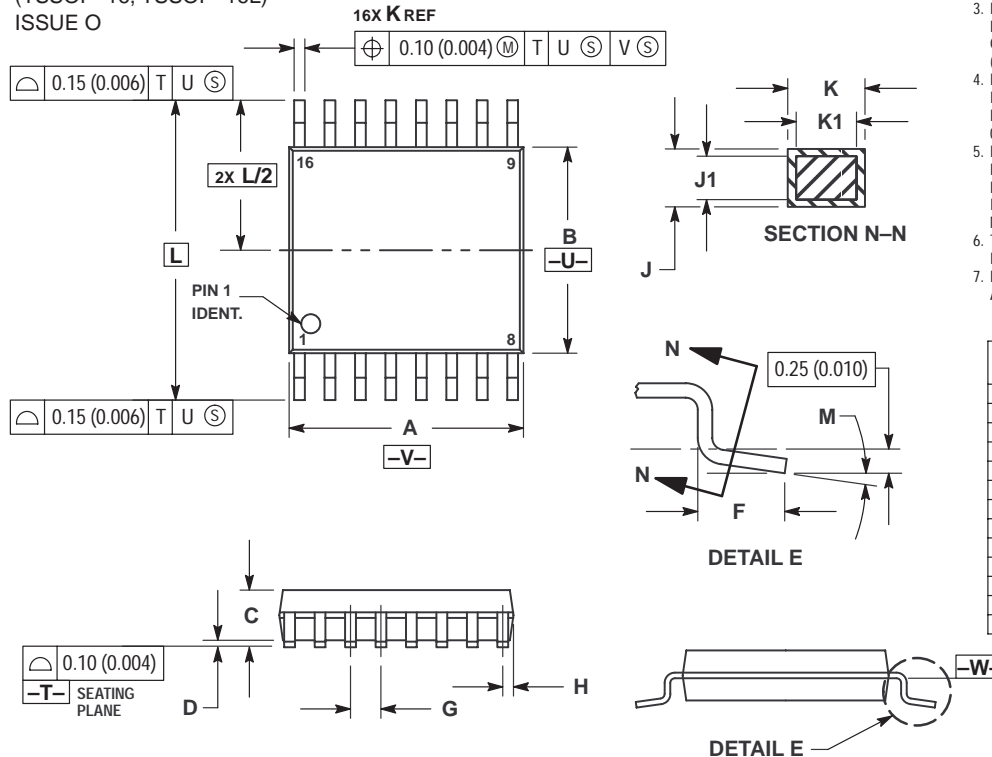
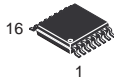

- NOTES:
1. DIMENSIONING AND TOLERANCING PER ANSI Y14.5M, 1982.
 2. CONTROLLING DIMENSION: MILLIMETER.
 3. DIMENSION A DOES NOT INCLUDE MOLD FLASH, PROTRUSIONS OR GATE BURRS. MOLD FLASH OR GATE BURRS SHALL NOT EXCEED 0.15 (0.006) PER SIDE.
 4. DIMENSION B DOES NOT INCLUDE INTERLEAD FLASH OR PROTRUSION. INTERLEAD FLASH OR PROTRUSION SHALL NOT EXCEED 0.25 (0.010) PER SIDE.
 5. DIMENSION K DOES NOT INCLUDE DAMBAR PROTRUSION. ALLOWABLE DAMBAR PROTRUSION SHALL BE 0.08 (0.003) TOTAL IN EXCESS OF THE K DIMENSION AT MAXIMUM MATERIAL CONDITION.
 6. TERMINAL NUMBERS ARE SHOWN FOR REFERENCE ONLY.
 7. DIMENSION A AND B ARE TO BE DETERMINED AT DATUM PLANE -W-.

| DIM | MILLIMETERS | | INCHES | |
|-----|-------------|------|-----------|-------|
| | MIN | MAX | MIN | MAX |
| A | 4.90 | 5.10 | 0.193 | 0.200 |
| B | 4.30 | 4.50 | 0.169 | 0.177 |
| C | --- | 1.20 | --- | 0.047 |
| D | 0.05 | 0.15 | 0.002 | 0.006 |
| F | 0.50 | 0.75 | 0.020 | 0.030 |
| G | 0.65 BSC | | 0.026 BSC | |
| H | 0.18 | 0.28 | 0.007 | 0.011 |
| J | 0.09 | 0.20 | 0.004 | 0.008 |
| J1 | 0.09 | 0.16 | 0.004 | 0.006 |
| K | 0.19 | 0.30 | 0.007 | 0.012 |
| K1 | 0.19 | 0.25 | 0.007 | 0.010 |
| L | 6.40 BSC | | 0.252 BSC | |
| M | 0° | 8° | 0° | 8° |

DTB SUFFIX
CASE 948G-01
 Plastic Package
 (TSSOP-14)
 ISSUE O

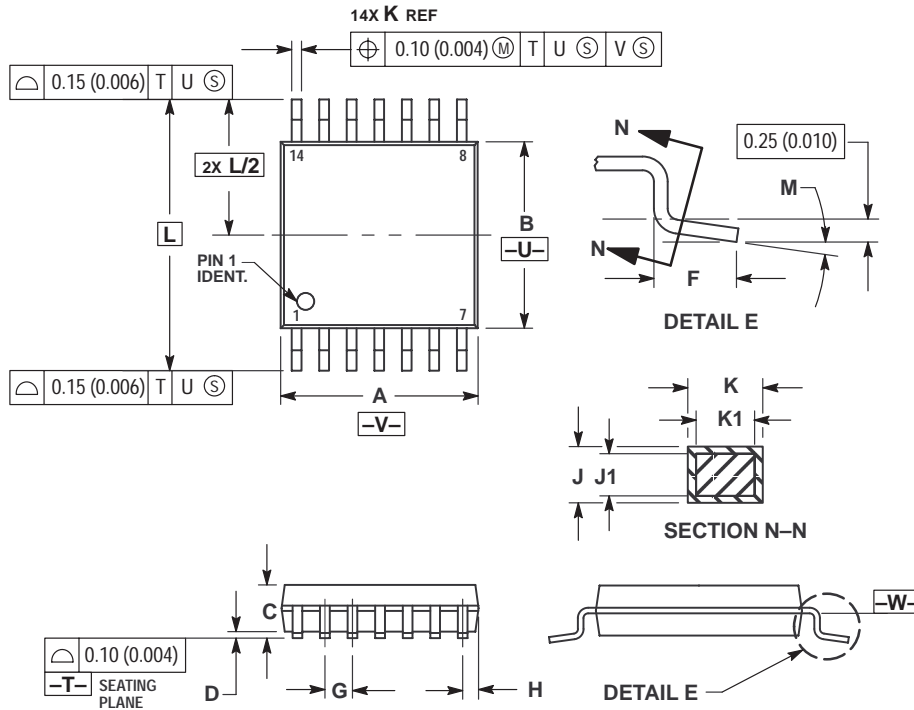

NOTES:

- 1 DIMENSIONING AND TOLERANCING PER ANSI Y14.5M, 1982.
- 2 CONTROLLING DIMENSION: MILLIMETER.
- 3 DIMENSION A DOES NOT INCLUDE MOLD FLASH, PROTRUSIONS OR GATE BURRS. MOLD FLASH OR GATE BURRS SHALL NOT EXCEED 0.15 (0.006) PER SIDE.
- 4 DIMENSION B DOES NOT INCLUDE INTERLEAD FLASH OR PROTRUSION. INTERLEAD FLASH OR PROTRUSION SHALL NOT EXCEED 0.25 (0.010) PER SIDE.
- 5 DIMENSION K DOES NOT INCLUDE DAMBAR PROTRUSION. ALLOWABLE DAMBAR PROTRUSION SHALL BE 0.08 (0.003) TOTAL IN EXCESS OF THE K DIMENSION AT MAXIMUM MATERIAL CONDITION.
- 6 TERMINAL NUMBERS ARE SHOWN FOR REFERENCE ONLY.
- 7 DIMENSION A AND B ARE TO BE DETERMINED AT DATUM PLANE -W-.

| DIM | MILLIMETERS | | INCHES | |
|-----|-------------|------|-----------|-------|
| | MIN | MAX | MIN | MAX |
| A | 4.90 | 5.10 | 0.193 | 0.200 |
| B | 4.30 | 4.50 | 0.169 | 0.177 |
| C | — | 1.20 | — | 0.047 |
| D | 0.05 | 0.15 | 0.002 | 0.006 |
| F | 0.50 | 0.75 | 0.020 | 0.030 |
| G | 0.65 BSC | | 0.026 BSC | |
| H | 0.50 | 0.60 | 0.020 | 0.024 |
| J | 0.09 | 0.20 | 0.004 | 0.008 |
| J1 | 0.09 | 0.16 | 0.004 | 0.006 |
| K | 0.19 | 0.30 | 0.007 | 0.012 |
| K1 | 0.19 | 0.25 | 0.007 | 0.010 |
| L | 6.40 BSC | | 0.252 BSC | |
| M | 0° | 8° | 0° | 8° |

DTB SUFFIX
CASE 948H-01
 Plastic Package
 ISSUE O

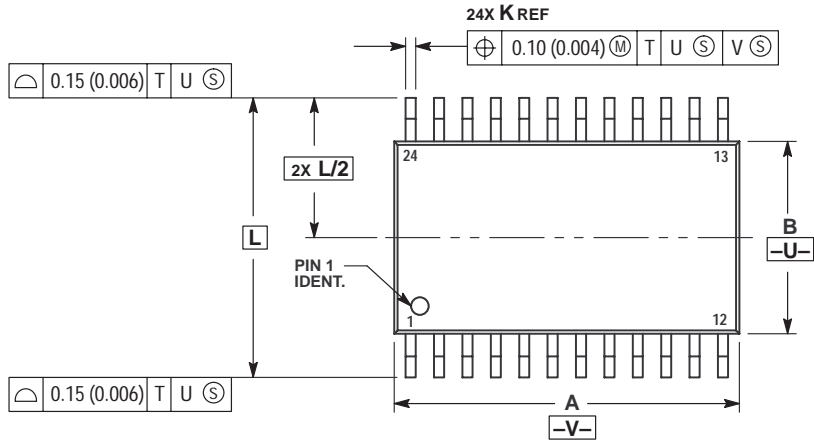
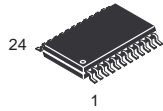

- NOTES:
1. DIMENSIONING AND TOLERANCING PER ANSI Y14.5M, 1982.
 2. CONTROLLING DIMENSION: MILLIMETER.
 3. DIMENSION A DOES NOT INCLUDE MOLD FLASH, PROTRUSIONS OR GATE BURRS. MOLD FLASH OR GATE BURRS SHALL NOT EXCEED 0.15 (0.006) PER SIDE.
 4. DIMENSION B DOES NOT INCLUDE INTERLEAD FLASH OR PROTRUSION. INTERLEAD FLASH OR PROTRUSION SHALL NOT EXCEED 0.25 (0.010) PER SIDE.
 5. DIMENSION K DOES NOT INCLUDE DAMBAR PROTRUSION. ALLOWABLE DAMBAR PROTRUSION SHALL BE 0.08 (0.003) TOTAL IN EXCESS OF THE K DIMENSION AT MAXIMUM MATERIAL CONDITION.
 6. TERMINAL NUMBERS ARE SHOWN FOR REFERENCE ONLY.
 7. DIMENSION A AND B ARE TO BE DETERMINED AT DATUM PLANE -W-.

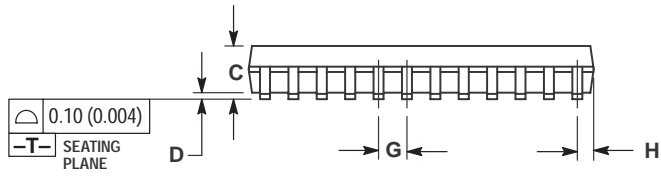

| DIM | MILLIMETERS | | INCHES | |
|-----|-------------|------|-----------|-------|
| | MIN | MAX | MIN | MAX |
| A | 7.70 | 7.90 | 0.303 | 0.311 |
| B | 4.30 | 4.50 | 0.169 | 0.177 |
| C | --- | 1.20 | --- | 0.047 |
| D | 0.05 | 0.15 | 0.002 | 0.006 |
| F | 0.50 | 0.75 | 0.020 | 0.030 |
| G | 0.65 BSC | | 0.026 BSC | |
| H | 0.27 | 0.37 | 0.011 | 0.015 |
| J | 0.09 | 0.20 | 0.004 | 0.008 |
| J1 | 0.09 | 0.16 | 0.004 | 0.006 |
| K | 0.19 | 0.30 | 0.007 | 0.012 |
| K1 | 0.19 | 0.25 | 0.007 | 0.010 |
| L | 6.40 BSC | | 0.252 BSC | |
| M | 0° | 8° | 0° | 8° |

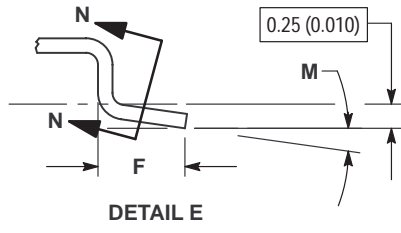
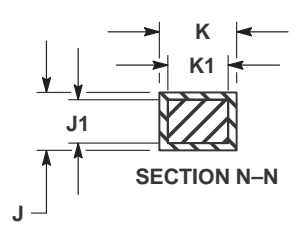
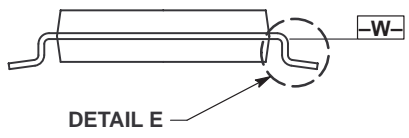

FTA SUFFIX
CASE 977-01
Plastic Package
ISSUE O

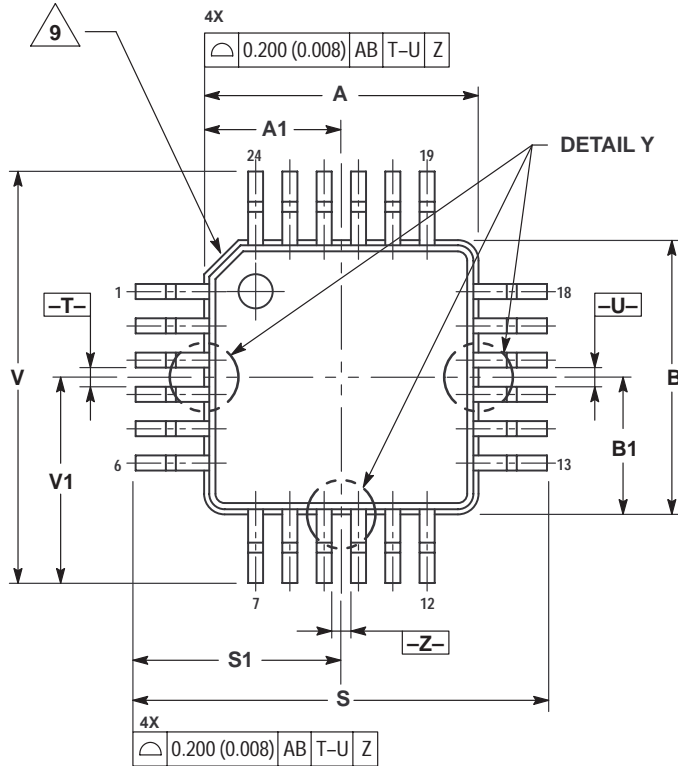
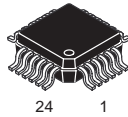

- NOTES:
1. DIMENSIONING AND TOLERANCING PER ANSI Y14.5M, 1982.
 2. CONTROLLING DIMENSION: MILLIMETER.
 3. DATUM PLANE -AB- IS LOCATED AT BOTTOM OF LEAD AND IS COINCIDENT WITH THE LEAD WHERE THE LEAD EXITS THE PLASTIC BODY AT THE BOTTOM OF THE PARTING LINE.
 4. DATUMS -T-, -U-, AND -Z- TO BE DETERMINED AT DATUM PLANE -AB-.
 5. DIMENSIONS S AND V TO BE DETERMINED AT DATUM PLANE -AC-.
 6. DIMENSIONS A AND B DO NOT INCLUDE MOLD PROTRUSION. ALLOWABLE PROTRUSION IS 0.250 (0.010) PER SIDE. DIMENSIONS A AND B DO INCLUDE MOLD MISMATCH AND ARE DETERMINED AT DATUM PLANE -AB-.
 7. DIMENSION D DOES NOT INCLUDE DAMBAR PROTRUSION. DAMBAR PROTRUSION SHALL NOT CAUSE THE D DIMENSION TO EXCEED 0.350 (0.014).
 8. MINIMUM SOLDER PLATE THICKNESS SHALL BE 0.0076 (0.0003).
 9. EXACT SHAPE OF EACH CORNER IS OPTIONAL.

| DIM | MILLIMETERS | | INCHES | |
|-----|-------------|-------|-----------|-------|
| | MIN | MAX | MIN | MAX |
| A | 4.000 BSC | | 0.157 BSC | |
| A1 | 2.000 BSC | | 0.079 BSC | |
| B | 4.000 BSC | | 0.157 BSC | |
| B1 | 2.000 BSC | | 0.079 BSC | |
| C | 1.400 | 1.600 | 0.055 | 0.063 |
| D | 0.170 | 0.270 | 0.007 | 0.011 |
| E | 1.350 | 1.450 | 0.053 | 0.057 |
| F | 0.170 | 0.230 | 0.007 | 0.009 |
| G | 0.500 BSC | | 0.020 BSC | |
| H | 0.050 | 0.150 | 0.002 | 0.006 |
| J | 0.090 | 0.200 | 0.004 | 0.008 |
| K | 0.500 | 0.700 | 0.020 | 0.028 |
| M | 12° REF | | 12° REF | |
| N | 0.090 | 0.160 | 0.004 | 0.006 |
| P | 0.250 BSC | | 0.010 BSC | |
| Q | 1° | 5° | 1° | 5° |
| R | 0.150 | 0.250 | 0.006 | 0.010 |
| S | 6.000 BSC | | 0.236 BSC | |
| S1 | 3.000 BSC | | 0.118 BSC | |
| V | 6.000 BSC | | 0.236 BSC | |
| V1 | 3.000 BSC | | 0.118 BSC | |
| W | 0.200 REF | | 0.008 REF | |
| X | 1.000 REF | | 0.039 REF | |

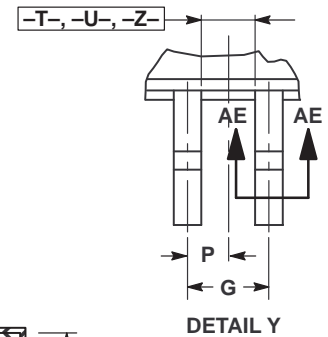
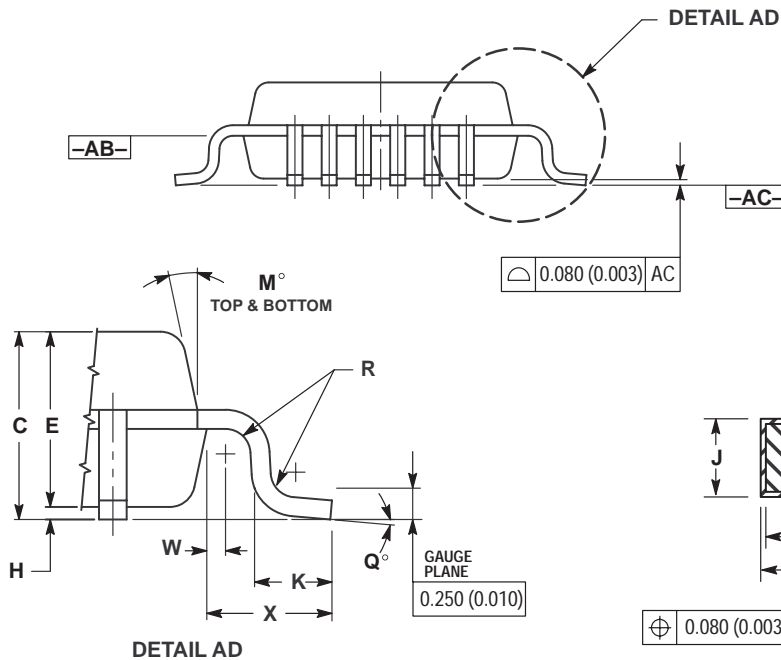

N SUFFIX
CASE 1212-01
 Plastic Package
 (SOT-23)
 ISSUE O

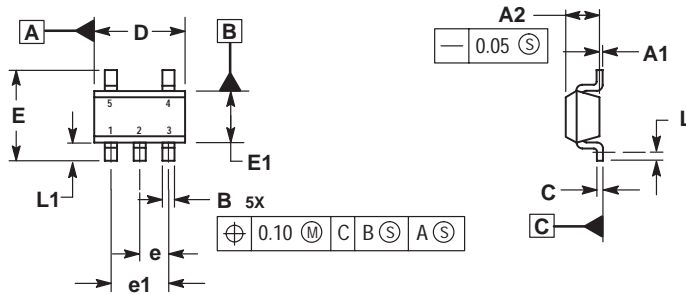

- NOTES:
 1. DIMENSIONS ARE IN MILLIMETERS.
 2. INTERPRET DIMENSIONS AND TOLERANCES PER ASME Y14.5M, 1994.
 3. DATUM C IS A SEATING PLANE.

| MILLIMETERS | | |
|-------------|----------|------|
| DIM | MIN | MAX |
| A1 | 0.00 | 0.10 |
| A2 | 1.00 | 1.30 |
| B | 0.30 | 0.50 |
| C | 0.10 | 0.25 |
| D | 2.80 | 3.00 |
| E | 2.50 | 3.10 |
| E1 | 1.50 | 1.80 |
| e | 0.95 BSC | |
| e1 | 1.90 BSC | |
| L | 0.20 | ---- |
| L1 | 0.45 | 0.75 |

H SUFFIX
CASE 1213-01
 Plastic Package
 (SOT-89)
 ISSUE O

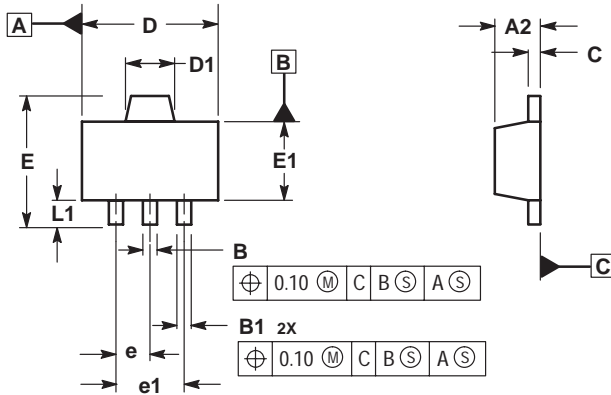

- NOTES:
 1. DIMENSIONS ARE IN MILLIMETERS.
 2. INTERPRET DIMENSIONS AND TOLERANCING PER ASME Y14.5M, 1994.
 3. DATUM C IS A SEATING PLANE.

| MILLIMETERS | | |
|-------------|----------|------|
| DIM | MIN | MAX |
| A2 | 1.40 | 1.60 |
| B | 0.37 | 0.57 |
| B1 | 0.32 | 0.52 |
| C | 0.30 | 0.50 |
| D | 4.40 | 4.60 |
| D1 | 1.50 | 1.70 |
| E | ---- | 4.25 |
| E1 | 2.40 | 2.60 |
| e | 1.50 BSC | |
| e1 | 3.00 BSC | |
| L1 | 0.80 | ---- |