

### Features

- Extremely low RMS phase jitter (random)
  - <1 ps (typical)
- 4 Pull range options
  - $\pm 30$ ,  $\pm 60$ ,  $\pm 120$ ,  $\pm 240$  PPM
- Wide frequency range
  - 1 MHz to 220 MHz
  - 220 MHz to 800 MHz (contact SiTime)
- High frequency stability
  - $\pm 10$  PPM,  $\pm 15$  PPM,  $\pm 20$  PPM
  - $\pm 25$  PPM,  $\pm 50$  PPM
- Operating voltage
  - 1.8, 2.5 or 3.3 V
- Operating temperature range
  - Industrial, -40 to 85 °C
  - Extended Commercial, -20 to 70 °C
  - Commercial, 0 to 70 °C
- Small footprint
  - 5.0 x 3.2 x 0.75 mm
  - 7.0 x 5.0 x 0.9 mm
- Pb-free and ROHs compliant

### Benefits

- Ultra fast lead time: 2 to 3 weeks
- Linear pull range
- Eliminates crystal qualification time
- 50% + board saving space
- More cost effective than quartz oscillators, quartz crystals and clock ICs.
- Completely quartz-free

### Applications

- 10G Fibre Channel
- 10GbE LAN / WAN
- Networking

### Block Diagram

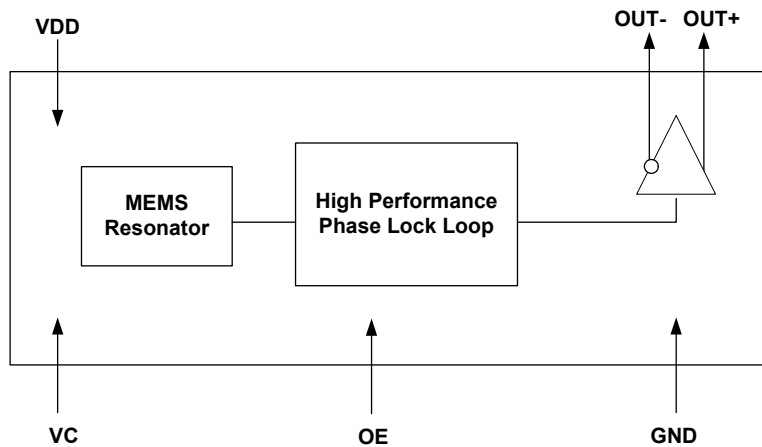

### Pinout

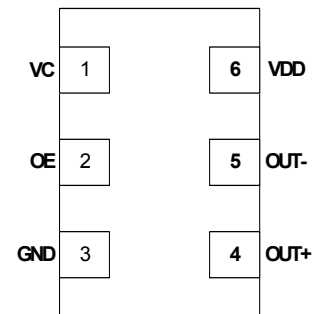

## Pin Description

Pin No.	Name		Pin Description
1	VC	Input	Input control voltage, 0 to 1.6 V
2	OE	Input	Output Enable: When High or Open : OUT+ and OUT- = active When Low : OUT+ and OUT- = High Impedance state
3	GND	Power	VDD power supply ground. Connect to Ground
4	OUT+	Output	800 MHz programmable clock output.
5	OUT-	Output	800 MHz programmable clock output.
6	VDD	Power	Power supply voltage

## Absolute Maximum Ratings

Attempted operation outside the absolute maximum ratings of the part may cause permanent damage to the part. Actual performance of the IC is only guaranteed within the operational specifications, not at absolute maximum ratings.

## Absolute Maximum Table

Parameter	Min.	Max.	Unit
Storage Temperature	-65	150	°C
VDD	-0.5	+4.00	V
Vin	GND - 0.5	VDD + 0.5	V
Theta JA (with copper plane on VDD and GND) 5.0 x 3.2 package	–	68	°C/W
7.0 x 5.0 package when center pad is soldered down	–	38	°C/W
7.0 x 5.0 package when center pad is not soldered down	–	90	°C/W
Theta JC (with PCB traces of 0.010 inch to all pins) 5.0 x 3.2 package	–	45	°C/W
7.0 x 5.0 package when center pad is soldered down	–	35	°C/W
7.0 x 5.0 package when center pad is not soldered down	–	48	°C/W
Soldering Temperature (follow standard Pb free soldering guidelines)	–	260	°C
Number of Program Writes	–	1	NA
Program Retention over -40 to 125°C, Process, VDD (0 to 3.6V)	–	1,000+	years
Human Body Model (JESD22-A114)	2000	–	–
Charged Device Model (JESD22-C101)	750	–	–
Machine Model (JESD22-A115)	200	–	–

## Environmental Compliance

Parameter	Condition/Test Method
Mechanical Shock	MIL-STD-883F, Method 2002, 50 KG Shock
Mechanical Vibration	MIL-STD-883F, Method 2007, 70 G Vibration
Temperature Cycle	MIL-STD-883F, Method 1010-65-150°C (1000 cycle)
Solderability	MIL-STD-883F, Method 2003
Moisture Sensibility Level	MSL1

## DC Electrical Specifications

LVC MOS input, OE or ST pin, 3.3V ±10% or 2.5V ±10% or 1.8V ±5%, -40 to 85°C

Symbol	Parameter	Condition	Min.	Typ.	Max.	Unit
V <sub>IH</sub>	Input High Voltage		70	–	–	%V <sub>DD</sub>
V <sub>IL</sub>	Input Low Voltage		–	–	30	%V <sub>DD</sub>
I <sub>IH</sub>	Input High Current	OE or ST pin	–	–	10	μA
I <sub>IL</sub>	Input Low Current	OE or ST pin	-10	–	–	μA

LVPECL, 3.3V ±10% or 2.5V ±10%, -40 to 85°C

Symbol	Parameter	Condition	Min.	Typ.	Max.	Unit
V <sub>DD</sub>	Supply Voltage		2.97	3.3	3.63	V
			2.25	2.5	2.75	V
I <sub>DD</sub>	Supply Current	V <sub>DD</sub> = 3.3, Excluding Load Termination Current	–	75	84	mA
		V <sub>DD</sub> = 3.3, Excluding Load Termination Current	–	75	84	mA
V <sub>OH</sub>	Output High Voltage	50 Ohm termination to V <sub>DD</sub> - 2.0V	V <sub>DD</sub> -1.1	–	V <sub>DD</sub> -0.7	V
V <sub>OL</sub>	Output Low Voltage	See Figure 2, 3.	V <sub>DD</sub> -2.0	–	V <sub>DD</sub> -1.4	V
V <sub>swing</sub>	Pk-Pk Output Voltage Swing		600	800	1000	mV

HCSL, 3.3V ±10% or 2.5V ±10%, -40 to 85°C

Symbol	Parameter	Condition	Min.	Typ.	Max.	Unit
V <sub>DD</sub>	Supply Voltage		2.97	3.3	3.63	V
			2.25	2.5	2.75	V
I <sub>DD</sub>	Supply Current	V <sub>DD</sub> = 3.3, Excluding Load Termination Current	–	73	80	mA
		V <sub>DD</sub> = 3.3, Excluding Load Termination Current	–	73	80	mA
V <sub>OH</sub>	Output High Voltage	50 Ohm termination to GND	0.6	0.75	0.95	V
V <sub>OL</sub>	Output Low Voltage	See Figure 4.	0.0	–	0.50	V
V <sub>swing</sub>	Pk-Pk Output Voltage Swing		600	750	950	mV

LVDS, 3.3V ±10% or 2.5V ±10%, -40 to 85°C

Symbol	Parameter	Condition	Min.	Typ.	Max.	Unit
V <sub>DD</sub>	Supply Voltage		2.97	3.3	3.63	V
			2.25	2.5	2.75	V
I <sub>DD</sub>	Supply Current	V <sub>DD</sub> = 3.3, Excluding Load Termination Current	–	75	85	mA
		V <sub>DD</sub> = 3.3, Excluding Load Termination Current	–	70	77	mA
V <sub>OD1</sub>	Differential Output Voltage	Swing Mode = Normal	250	350	450	mV
ΔV <sub>OD1</sub>	V <sub>OD</sub> Magnitude Change	Single load termination. See Figure 5.	–	–	50	mV
V <sub>OS1</sub>	Offset Voltage		–	1.2	–	V
ΔV <sub>OS1</sub>	V <sub>OS</sub> Magnitude Change		–	–	50	mV
V <sub>OD2</sub>	Differential Output Voltage	Swing Mode = High	500	700	900	mV
ΔV <sub>OD2</sub>	V <sub>OD</sub> Magnitude Change	Single load termination. See Figure 5.	–	–	50	mV
V <sub>OS2</sub>	Offset Voltage		–	1.2	–	V
ΔV <sub>OS2</sub>	V <sub>OS</sub> Magnitude Change		–	–	50	mV
V <sub>OD3</sub>	Differential Output Voltage	Swing Mode = High	250	350	450	mV
ΔV <sub>OD3</sub>	V <sub>OD</sub> Magnitude Change	Double load termination. See Figure 6.	–	–	50	mV
V <sub>OS3</sub>	Offset Voltage		–	1.2	–	V
ΔV <sub>OS3</sub>	V <sub>OS</sub> Magnitude Change		–	–	50	mV

CML, 3.3V ±10% or 2.5V ±10% or 1.8V ±5%, -40 to 85°C

Symbol	Parameter	Condition	Min.	Typ.	Max.	Unit	
V <sub>DD</sub>	Supply Voltage		2.97	3.3	3.63	V	
			2.25	2.5	2.75	V	
			1.71	1.8	1.89	V	
I <sub>DD</sub>	Supply Current	V <sub>DD</sub> = 3.3V	Excluding Load Termination Current	–	48	51	mA
		V <sub>DD</sub> = 2.5V		–	48	51	mA
		V <sub>DD</sub> = 1.8V		–	48	51	mA
V <sub>OH1</sub>	Output High Voltage	Swing Mode = Normal Single Load Termination See Figure 7.	V <sub>DD</sub> -0.1	–	V <sub>DD</sub>	V	
V <sub>OL1</sub>	Output Low Voltage		V <sub>DD</sub> -0.55	V <sub>DD</sub> -0.425	V <sub>DD</sub> -0.3	V	
V <sub>swing1</sub>	Pk-Pk Output Voltage Swing		300	425	550	mV	
V <sub>OH2</sub>	Output High Voltage	Swing Mode = High Single Load Termination See Figure 7.	V <sub>DD</sub> -0.1	–	V <sub>DD</sub>	V	
V <sub>OL2</sub>	Output Low Voltage		V <sub>DD</sub> -1.1	V <sub>DD</sub> -0.85	V <sub>DD</sub> -0.6	V	
V <sub>swing2</sub>	Pk-Pk Output Voltage Swing		600	850	1100	mV	
V <sub>OH3</sub>	Output High Voltage	Swing Mode = High Double Load Termination See Figure 8.	V <sub>DD</sub> -0.1	–	V <sub>DD</sub>	V	
V <sub>OL3</sub>	Output Low Voltage		V <sub>DD</sub> -0.55	V <sub>DD</sub> -0.425	V <sub>DD</sub> -0.3	V	
V <sub>swing3</sub>	Pk-Pk Output Voltage Swing		300	425	550	mV	

## AC Electrical Specifications

LVPECL, 3.3V ±10% , -40 to 85°C

Symbol	Parameter	Condition	Min.	Typ.	Max.	Unit	
F <sub>out</sub>	Output Frequency		1.0	–	220	MHz	
F <sub>sta</sub>	Frequency Stability	Inclusive of initial tolerance, operating temp., rated power supply voltage change, load change	0 to 70°C	-10	–	+10	PPM
			-20 to 70°C	-15	–	+15	PPM
			-40 to 85°C	-20	–	+20	PPM
				-25		+25	PPM
				-50		+50	PPM
F <sub>age</sub>	Aging	First year @ 25°C	–	–	1	PPM	
DC	Duty Cycle		45	–	55	%	
t <sub>R</sub> /t <sub>F</sub>	Output Rise/Fall Time	20% to 80%	100	150	300	ps	
PH <sub>J</sub>	RMS Phase Jitter (random)	F <sub>out</sub> = 106.25 MHz @ BW: 637 kHz to 10 MHz	–	1.6	–	ps	
		F <sub>out</sub> = 156.25 MHz @ BW: 1.875 to 20 MHz	–	0.5	–	ps	
		F <sub>out</sub> = 200 MHz @ BW: 1 to 20 MHz	–	0.7	–	ps	
P <sub>J</sub>	RMS Period Jitter	F <sub>out</sub> = 106.25 MHz	–	1.8	2.3	ps	
		F <sub>out</sub> = 156.25 MHz	–	1.3	1.8	ps	
		F <sub>out</sub> = 200 MHz	–	1.3	1.8	ps	

LVPECL, 2.5V ±10%, -40 to 85°C

Symbol	Parameter	Condition	Min.	Typ.	Max.	Unit	
F <sub>out</sub>	Output Frequency		1.0	–	220	MHz	
F <sub>sta</sub>	Frequency Stability	Inclusive of initial tolerance, operating temp., rated power supply voltage change, load change	0 to 70°C	-10	–	+10	PPM
			-20 to 70°C	-15	–	+15	PPM
			-40 to 85°C	-20	–	+20	PPM
				-25		+25	PPM
				-50		+50	PPM
F <sub>age</sub>	Aging	First year @ 25°C	–	–	1	PPM	
DC	Duty Cycle		45	–	55	%	
t <sub>R</sub> /t <sub>F</sub>	Output Rise/Fall Time	20% to 80%	100	150	300	ps	
PH <sub>J</sub>	RMS Phase Jitter (random)	F <sub>out</sub> = 106.25 MHz @ BW: 637 kHz to 10 MHz	–	1.6	–	ps	
		F <sub>out</sub> = 156.25 MHz @ BW: 1.875 to 20 MHz	–	0.5	–	ps	
		F <sub>out</sub> = 200 MHz @ BW: 1 to 20 MHz	–	0.7	–	ps	
P <sub>J</sub>	RMS Period Jitter	F <sub>out</sub> = 106.25 MHz	–	1.8	2.3	ps	
		F <sub>out</sub> = 156.25 MHz	–	1.3	1.8	ps	
		F <sub>out</sub> = 200 MHz	–	1.3	1.8	ps	

HCSL, 3.3V ±10%, -40 to 85°C

Symbol	Parameter	Condition	Min.	Typ.	Max.	Unit	
F <sub>out</sub>	Output Frequency		1.0	–	220	MHz	
F <sub>sta</sub>	Frequency Stability	Inclusive of initial tolerance, operating temp., rated power supply voltage change, load change	0 to 70°C	-10	–	+10	PPM
			-20 to 70°C	-15	–	+15	PPM
			-40 to 85°C	-20	–	+20	PPM
				-25		+25	PPM
				-50		+50	PPM
F <sub>age</sub>	Aging	First year @ 25°C	–	–	1	PPM	
DC	Duty Cycle		45	–	55	%	
t <sub>R</sub> /t <sub>F</sub>	Output Rise/Fall Time	20% to 80%	200	280	375	ps	
PH <sub>J</sub>	RMS Phase Jitter (random)	F <sub>out</sub> = 100 MHz @ BW: 1.5 MHz to 22 MHz	–	0.8	–	ps	
		F <sub>out</sub> = 200 MHz @ BW: 1.5 MHz to 22 MHz	–	0.4	–	ps	
P <sub>J</sub>	RMS Period Jitter	F <sub>out</sub> = 100 MHz	–	1.6	2.2	ps	
		F <sub>out</sub> = 200 MHz	–	1.5	1.9	ps	

HCSSL, 2.5V ±10%, -40 to 85°C

Symbol	Parameter	Condition	Min.	Typ.	Max.	Unit	
F <sub>out</sub>	Output Frequency		1.0	–	220	MHz	
F <sub>sta</sub>	Frequency Stability	Inclusive of initial tolerance, operating temp., rated power supply voltage change, load change	0 to 70°C	-10	–	+10	PPM
			-20 to 70°C	-15	–	+15	PPM
			-40 to 85°C	-20	–	+20	PPM
				-25		+25	PPM
				-50		+50	PPM
F <sub>age</sub>	Aging	First year @ 25°C	–	–	1	PPM	
DC	Duty Cycle		45	–	55	%	
t <sub>R</sub> /t <sub>F</sub>	Output Rise/Fall Time	20% to 80%	200	300	400	ps	
PH <sub>J</sub>	RMS Phase Jitter (random)	F <sub>out</sub> = 100 MHz @ BW: 1.5 MHz to 22 MHz	–	0.8	–	ps	
		F <sub>out</sub> = 200 MHz @ BW: 1.5 MHz to 22 MHz	–	0.4	–	ps	
P <sub>J</sub>	RMS Period Jitter	F <sub>out</sub> = 100 MHz	–	1.6	2.2	ps	
		F <sub>out</sub> = 200 MHz	–	1.5	2.1	ps	

LVDS, 3.3V ±10%, -40 to 85°C

Symbol	Parameter	Condition	Min.	Typ.	Max.	Unit	
F <sub>out</sub>	Output Frequency		1.0	–	220	MHz	
F <sub>sta</sub>	Frequency Stability	Inclusive of initial tolerance, operating temp., rated power supply voltage change, load change	0 to 70°C	-10	–	+10	PPM
			-20 to 70°C	-15	–	+15	PPM
			-40 to 85°C	-20	–	+20	PPM
				-25		+25	PPM
				-50		+50	PPM
F <sub>age</sub>	Aging	First year @ 25°C	–	–	1	PPM	
DC	Duty Cycle		45	–	55	%	
t <sub>R</sub> /t <sub>F</sub>	Output Rise/Fall Time	20% to 80%	100	200	325	ps	
PH <sub>J</sub>	RMS Phase Jitter (random)	F <sub>out</sub> = 106.25 MHz @ BW: 637 kHz to 10 MHz	–	1.7	–	ps	
		F <sub>out</sub> = 156.25 MHz @ BW: 1.875 to 20 MHz	–	0.7	–	ps	
		F <sub>out</sub> = 200 MHz @ BW: 1 to 20 MHz	–	0.7	–	ps	
P <sub>J</sub>	RMS Period Jitter	F <sub>out</sub> = 106.25 MHz	–	2.0	2.7	ps	
		F <sub>out</sub> = 156.25 MHz	–	1.8	2.5	ps	
		F <sub>out</sub> = 200 MHz	–	1.8	2.5	ps	

LVDS, 2.5V ±10%, -40 to 85°C

Symbol	Parameter	Condition	Min.	Typ.	Max.	Unit	
F <sub>out</sub>	Output Frequency		1.0	–	220	MHz	
F <sub>sta</sub>	Frequency Stability	Inclusive of initial tolerance, operating temp., rated power supply voltage change, load change	0 to 70°C	-10	–	+10	PPM
			-20 to 70°C	-15	–	+15	PPM
			-40 to 85°C	-20	–	+20	PPM
				-25		+25	PPM
				-50		+50	PPM
F <sub>age</sub>	Aging	First year @ 25°C	–	–	1	PPM	
DC	Duty Cycle		45	–	55	%	
t <sub>R</sub> /t <sub>F</sub>	Output Rise/Fall Time	20% to 80%	100	260	325	ps	
PH <sub>J</sub>	RMS Phase Jitter (random)	F <sub>out</sub> = 106.25 MHz @ BW: 637 kHz to 10 MHz	–	1.7	–	ps	
		F <sub>out</sub> = 156.25 MHz @ BW: 1.875 to 20 MHz	–	0.7	–	ps	
		F <sub>out</sub> = 200 MHz @ BW: 1 to 20 MHz	–	0.7	–	ps	
P <sub>J</sub>	RMS Period Jitter	F <sub>out</sub> = 106.25 MHz	–	2.5	3.3	ps	
		F <sub>out</sub> = 156.25 MHz	–	2.4	3.5	ps	
		F <sub>out</sub> = 200 MHz	–	2.4	3.5	ps	

CML, 3.3V ±10%, -40 to 85°C

Symbol	Parameter	Condition	Min.	Typ.	Max.	Unit	
F <sub>out</sub>	Output Frequency		1.0	–	220	MHz	
F <sub>sta</sub>	Frequency Stability	Inclusive of initial tolerance, operating temp., rated power supply voltage change, load change	0 to 70°C	-10	–	+10	PPM
			-20 to 70°C	-15	–	+15	PPM
			-40 to 85°C	-20	–	+20	PPM
				-25		+25	PPM
				-50		+50	PPM
F <sub>age</sub>	Aging	First year @ 25°C	–	–	1	PPM	
DC	Duty Cycle		45	–	55	%	
t <sub>R</sub> /t <sub>F</sub>	Output Rise/Fall Time	20% to 80%	150	220	300	ps	
PH <sub>J</sub>	RMS Phase Jitter (random)	F <sub>out</sub> = 106.25 MHz @ BW: 637 kHz to 10 MHz	–	1.6	–	ps	
		F <sub>out</sub> = 156.25 MHz @ BW: 1.875 to 20 MHz	–	0.6	–	ps	
		F <sub>out</sub> = 200 MHz @ BW: 1 to 20 MHz	–	0.8	–	ps	
P <sub>J</sub>	RMS Period Jitter	F <sub>out</sub> = 106.25 MHz	–	2	2.5	ps	
		F <sub>out</sub> = 156.25 MHz	–	1.9	2.5	ps	
		F <sub>out</sub> = 200 MHz	–	1.9	2.4	ps	

CML, 2.5V ± 10%, -40 to 85°C

Symbol	Parameter	Condition	Min.	Typ.	Max.	Unit	
F <sub>out</sub>	Output Frequency		1.0	–	220	MHz	
F <sub>sta</sub>	Frequency Stability	Inclusive of initial tolerance, operating temp., rated power supply voltage change, load change	0 to 70°C	-10	–	+10	PPM
			-20 to 70°C -40 to 85°C	-15	–	+15	PPM
				-20	–	+20	PPM
				-25		+25	PPM
				-50		+50	PPM
F <sub>age</sub>	Aging	First year @ 25°C	–	–	1	PPM	
DC	Duty Cycle		45	–	55	%	
t <sub>R</sub> /t <sub>F</sub>	Output Rise/Fall Time	20% to 80%	150	230	300	ps	
PH <sub>J</sub>	RMS Phase Jitter (random)	F <sub>out</sub> = 106.25 MHz @ BW: 637 kHz to 10 MHz	–	1.6	–	ps	
		F <sub>out</sub> = 156.25 MHz @ BW: 1.875 to 20 MHz	–	0.6	–	ps	
		F <sub>out</sub> = 200 MHz @ BW: 1 to 20 MHz	–	0.8	–	ps	
P <sub>J</sub>	RMS Period Jitter	F <sub>out</sub> = 106.25 MHz	–	2.1	2.5	ps	
		F <sub>out</sub> = 156.25 MHz	–	1.9	2.5	ps	
		F <sub>out</sub> = 200 MHz	–	1.9	2.5	ps	

CML, 1.8V ± 5%, -40 to 85°C

Symbol	Parameter	Condition	Min.	Typ.	Max.	Unit	
F <sub>out</sub>	Output Frequency		1.0	–	220	MHz	
F <sub>sta</sub>	Frequency Stability	Inclusive of initial tolerance, operating temp., rated power supply voltage change, load change	0 to 70°C	-15	–	+15	PPM
			-20 to 70°C -40 to 85°C	-20	–	+20	PPM
				-25		+25	PPM
				-50		+50	PPM
				F <sub>age</sub>	Aging	First year @ 25°C	–
DC	Duty Cycle		45	–	55	%	
t <sub>R</sub> /t <sub>F</sub>	Output Rise/Fall Time	20% to 80%	150	240	325	ps	
PH <sub>J</sub>	RMS Phase Jitter (random)	F <sub>out</sub> = 106.25 MHz @ BW: 637 kHz to 10 MHz	–	1.7	–	ps	
		F <sub>out</sub> = 156.25 MHz @ BW: 1.87 to 20 MHz	–	0.6	–	ps	
		F <sub>out</sub> = 200 MHz @ BW: 1 to 20 MHz	–	0.8	–	ps	
P <sub>J</sub>	RMS Period Jitter	F <sub>out</sub> = 106.25 MHz	–	2.3	2.9	ps	
		F <sub>out</sub> = 156.25 MHz	–	2.1	2.7	ps	
		F <sub>out</sub> = 200 MHz	–	2.1	2.7	ps	

Termination Diagrams

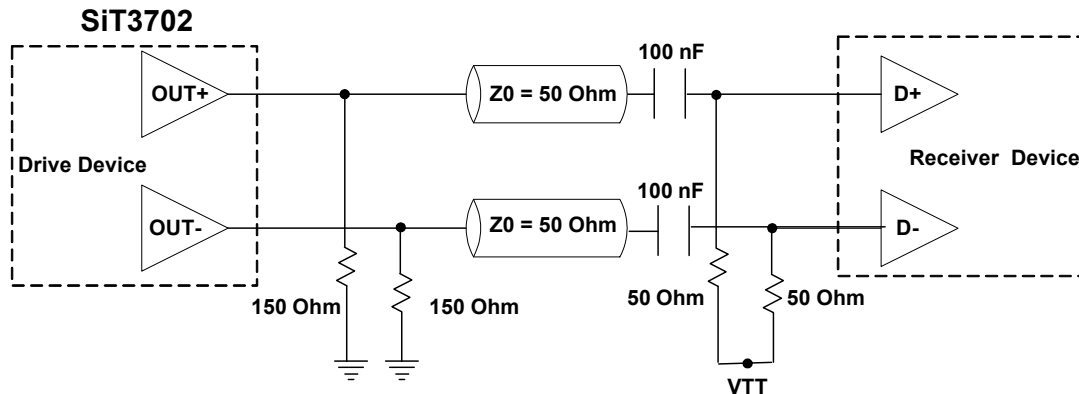

Figure 1. LVPECL AC Coupled Typical Termination

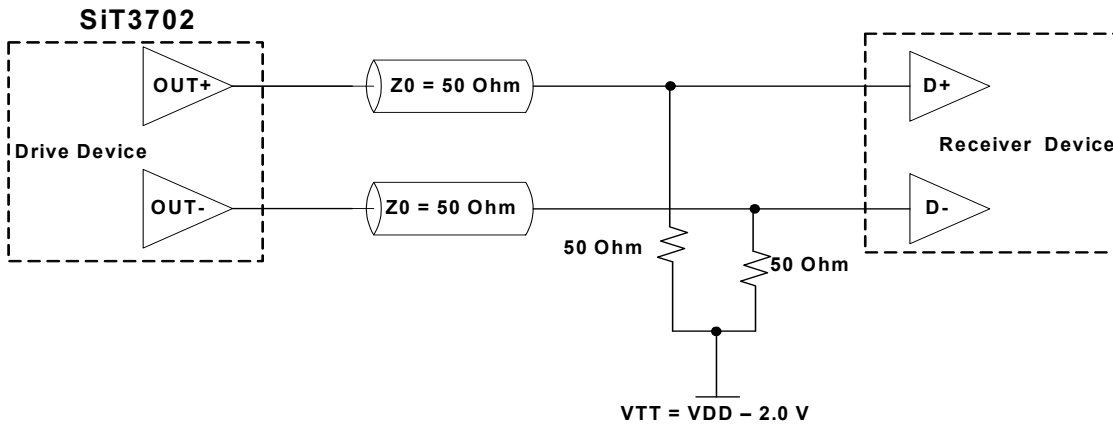

Figure 2. LVPECL DC Coupled Typical Termination with Termination Voltage

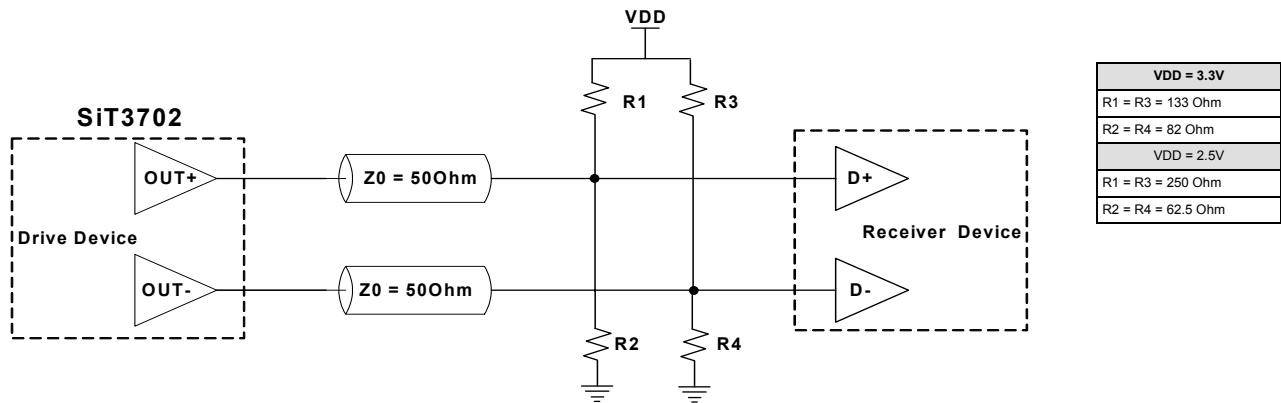
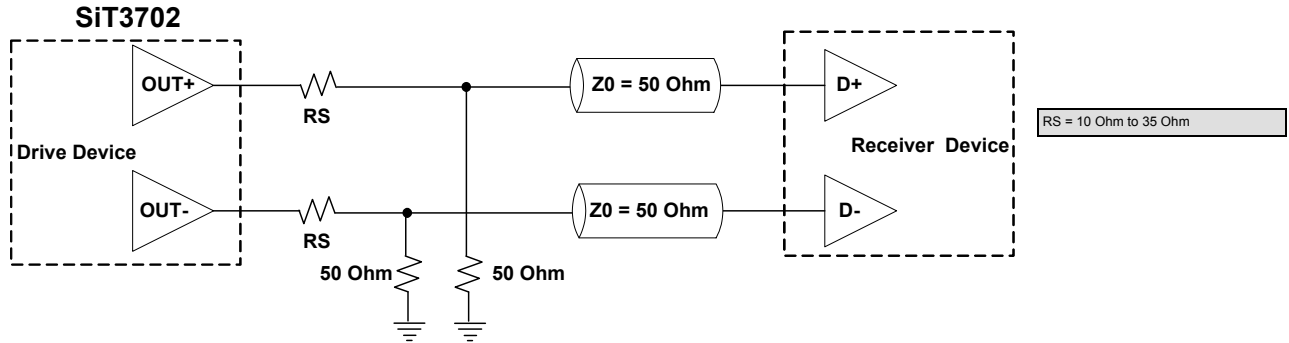

Figure 3. LVPECL DC Coupled Typical Termination without Termination Voltage



**Figure 4. HCSL Typical Termination**

**Note:**

1. All the tests are done with  $R_S = 20 \text{ Ohm}$  (recommended).

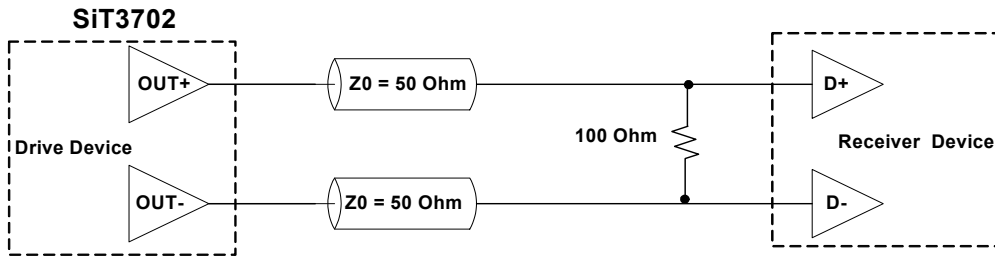

**Figure 5. LVDS Single Termination (Load Terminated)**

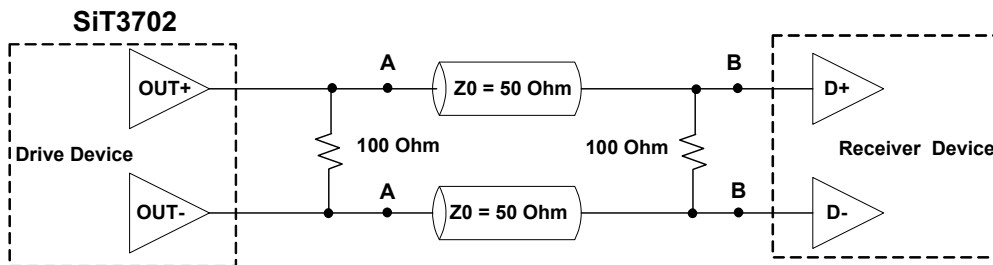

*Note: For AC coupled operation, include/insert decoupling caps at points A or B*

**Figure 6. LVDS Double Termination (Source + Load Terminated)**

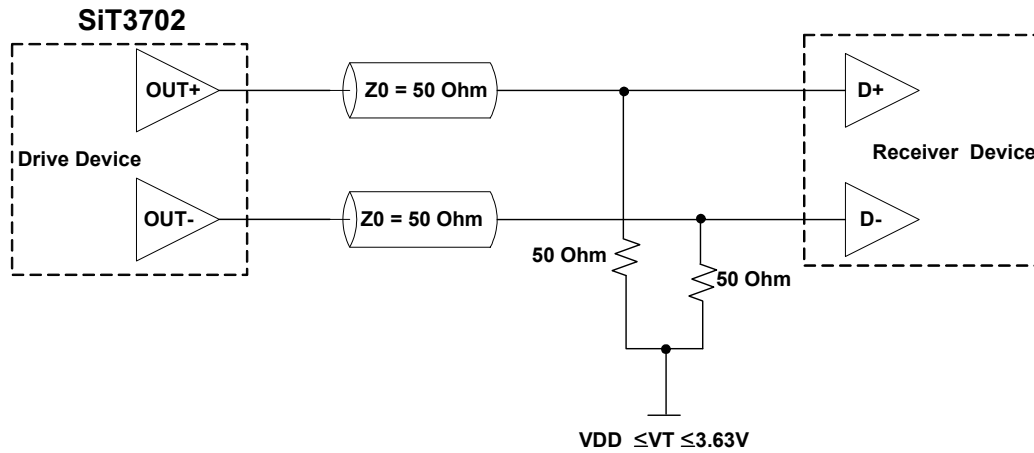
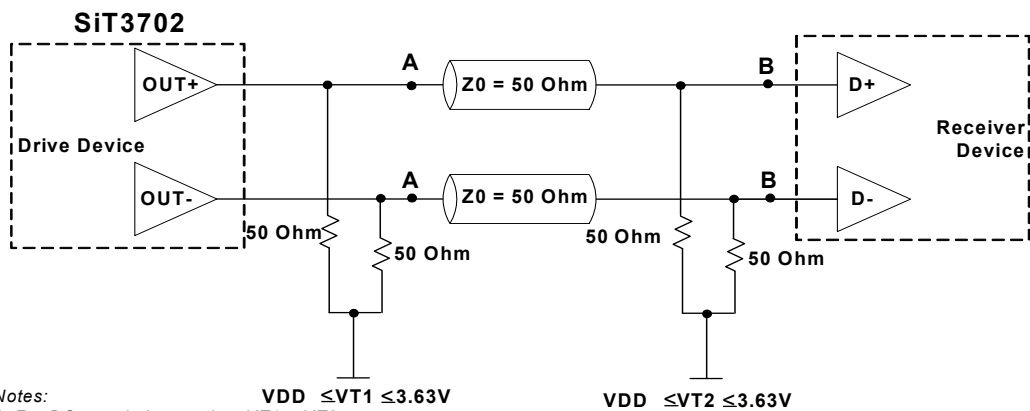

Figure 7. CML Single Load Termination



Notes:

1. For DC-coupled operation,  $VT1 = VT2$
2. For AC coupled operation, include/insert decoupling caps at points A or B
2. For AC-coupled operation with capacitors placed at point A,  $VT2$  sets the input common mode of Receiver Device and need not to be related to  $VT1$

Figure 8. CML Double Load Termination

## Ordering Information

### SiT3702AC- 132N33F123.12345T

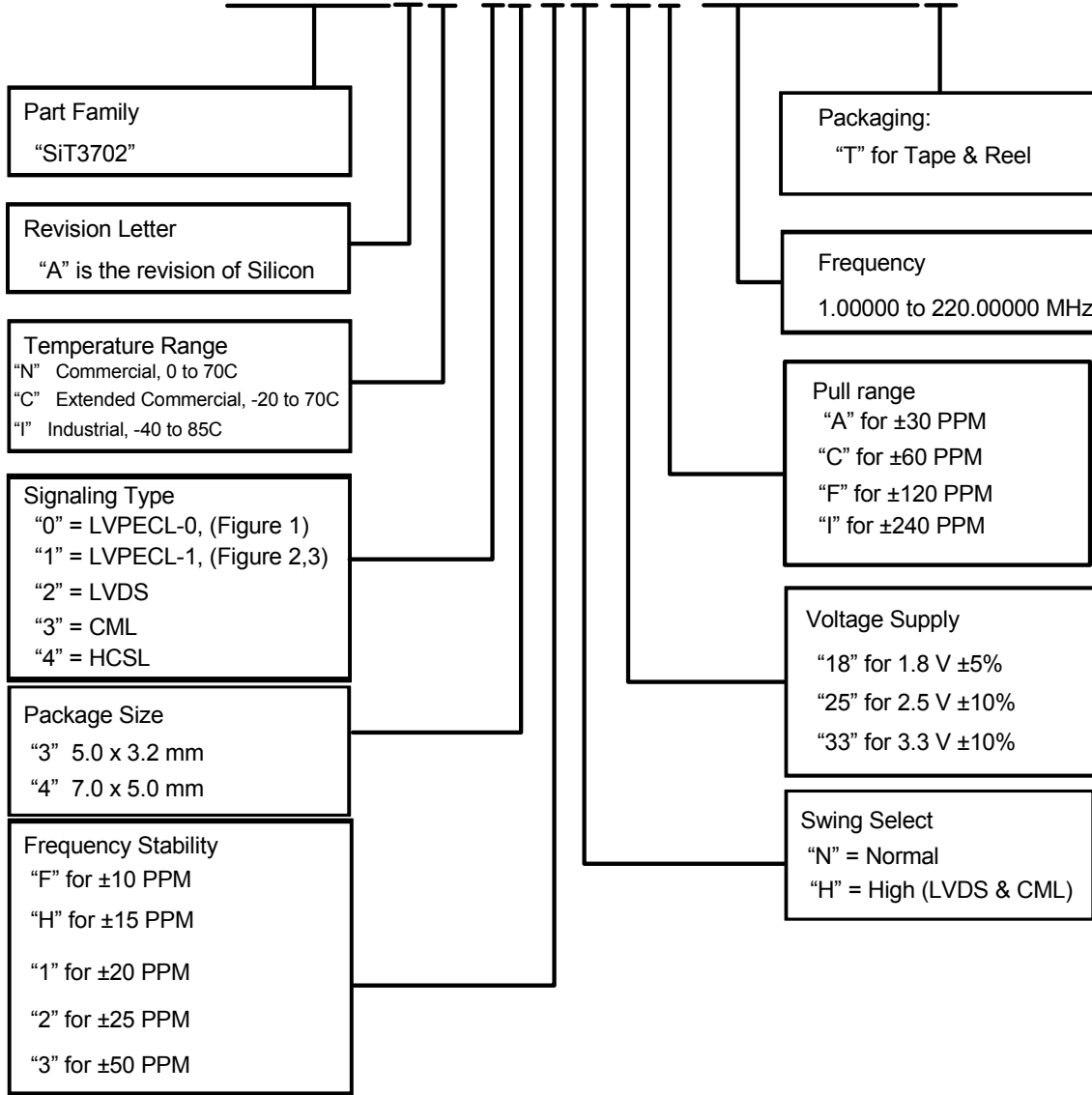

Frequency Stability	Temperature Range		
	N = 0 to 70C	C = -20 to 70C	I = -40 to 85C
± 10 PPM	VDD = 3.3 or 2.5 V	NA	NA
± 15 PPM	VDD = 1.8 or 2.5 or 3.3 V	VDD = 2.5 or 3.3 V	VDD = 2.5 or 3.3 V
± 20 PPM	NA	All VDDs	
± 25 PPM	NA		
± 50 PPM	NA		

**Package Information [1]**

**Dimension (mm)**

**Land Pattern [2] (recommended) (mm)**

**5.0 x 3.2 x 0.75mm**

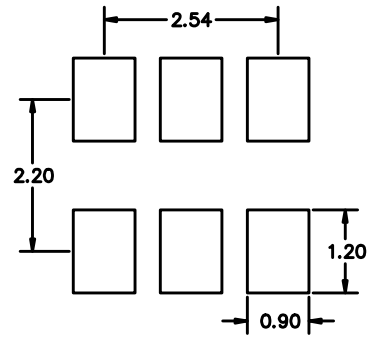
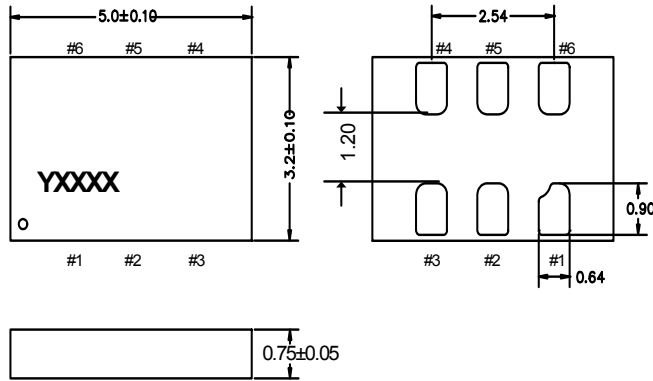

**Notes:**

1. xxxx top marking denotes manufacturing lot number.
2. A capacitor of value 0.1µF between VDD and GND is recommended

**7.0 x 5.0 x 0.9mm**

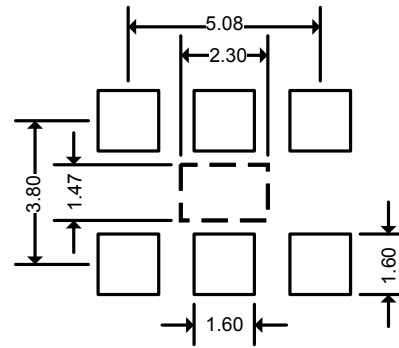
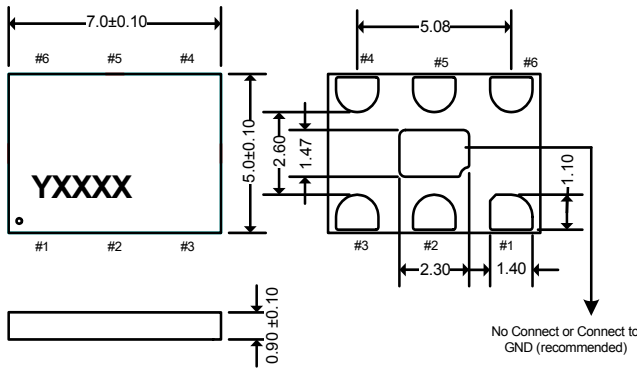

© SiTime Corporation 2009. The information contained herein is subject to change at any time without notice. SiTime assumes no responsibility or liability for any loss, damage or defect of a Product which is caused in whole or in part by (i) use of any circuitry other than circuitry embodied in a SiTime product, (ii) misuse or abuse including static discharge, neglect or accident, (iii) unauthorized modification or repairs which have been soldered or altered during assembly and are not capable of being tested by SiTime under its normal test conditions, or (iv) improper installation, storage, handling, warehousing or transportation, or (v) being subjected to unusual physical, thermal, or electrical stress.

**Disclaimer:** SiTime makes no warranty of any kind, express or implied, with regard to this material, and specifically disclaims any and all express or implied warranties, either in fact or by operation of law, statutory or otherwise, including the implied warranties of merchantability and fitness for use or a particular purpose, and any implied warranty arising from course of dealing or usage of trade, as well as any common-law duties relating to accuracy or lack of negligence, with respect to this material, any SiTime product and any product documentation. Products sold by SiTime are not suitable or intended to be used in a life support application or component, to operate nuclear facilities, or in other mission critical applications where human life may be involved or at stake. All sales are made conditioned upon compliance with the critical uses policy set forth below.

**CRITICAL USE EXCLUSION POLICY**  
 BUYER AGREES NOT TO USE SITIME'S PRODUCTS FOR ANY APPLICATION OR IN ANY COMPONENTS USED IN LIFE SUPPORT DEVICES OR TO OPERATE NUCLEAR FACILITIES OR FOR USE IN OTHER MISSION-CRITICAL APPLICATIONS OR COMPONENTS WHERE HUMAN LIFE OR PROPERTY MAY BE AT STAKE.

SiTime owns all rights, title and interest to the intellectual property related to SiTime's products, including any software, firmware, copyright, patent, or trademark. The sale of SiTime products does not convey or imply any license under patent or other rights. SiTime retains the copyright and trademark rights in all documents, catalogs and plans supplied pursuant to or ancillary to the sale of products or services by SiTime. Unless otherwise agreed to in writing by SiTime, any reproduction, modification, translation, compilation, or representation of this material shall be strictly prohibited.