

DESCRIPTION

The SSI 32R2100R/2101R/2102R are BiCMOS monolithic integrated circuits designed for use with two-terminal recording heads. They provide a low noise read amplifier, a high performance write driver, write current control, and data protection circuitry for up to 10 channels. The SSI 32R2100R/2101R/2102R option provides internal 250Ω damping resistors. Damping resistors are switched in during write mode and switched out during read mode. The SSI 32R2100/2101/2102 option does not provide damping resistors. Power supply fault protection is provided by disabling the write current generator during power sequencing. System write to read recovery time is significantly improved by making the read channel outputs high impedance. The device also offers multiple channel "servo bank write" capability to assist in servo writing operations.

The SSI 32R2100R/2101R/2102R requires 5V and 12V power supplies. The SSI 32R2100R provides PECL write data input. The SSI 32R2101R provides TTL write data input. The SSI 32R2102R provides PECL direct write data input without flip-flop.

FEATURES

- 5V ±10%, 12V ±10% supply
- Low power
 - PD = 235 mW read mode (Nom)
 - PD = 12 mW Idle (Max)
- High Performance:
 - Read mode gain = 150 V/V
 - Input noise = 0.45 nV/√Hz (Nom)
 - Input capacitance = 10 pF (Nom)
 - Write current range = 10-40 mA
 - Max write current rise/fall time = 7 ns (typical head)
 - Head voltage swing = 11 Vp-p min
- Servo bank-write capability
- Self switching damping resistance
- Write unsafe detection
- Power supply fault protection
- Head short to ground protection
- Differential ECL-like (32R2100R/2102R) or TTL (32R2101R) write data inputs

3

32R2100R BLOCK DIAGRAM

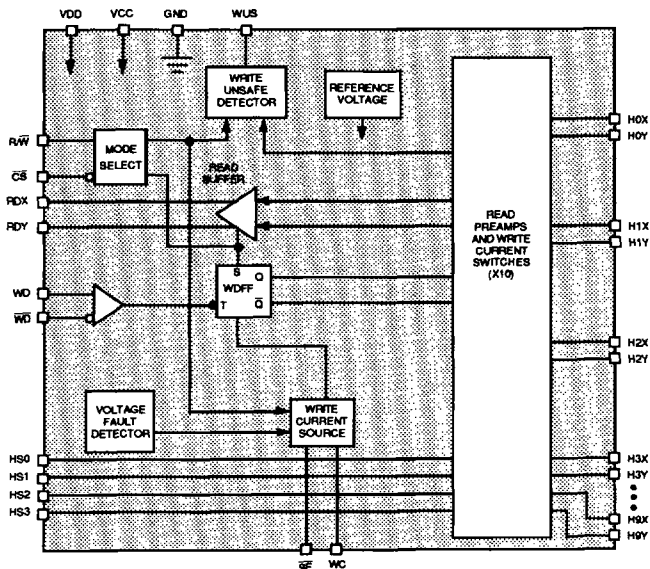

PIN DIAGRAM

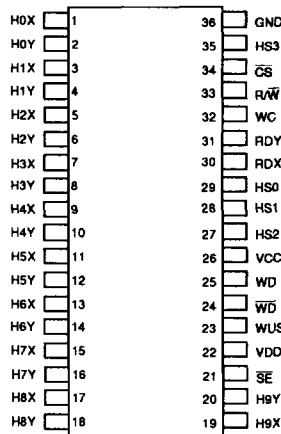

SSI 32R2100R - 36-Lead, 10-Channel SOM

CAUTION: Use handling procedures necessary for a static sensitive component.

SSI32R2100R/2101R/2102R

10 Channel Thin Film

Read/Write Devices

CIRCUIT OPERATION

The SSI 32R2100R/2101R/2102R has the ability to address up to 10 two-terminal heads and provide write drive or read amplification. Mode control and head selection are described in Tables 1, 2 and 3. The TTL inputs R/W, \overline{SE} and \overline{CS} have internal pull-up circuitry to prevent an accidental write condition. HS0, HS1, HS2 and HS3 have internal pulldown circuitry. Internal current limit circuitry will protect the IC from a head short to ground condition in any write mode.

TABLE 1: Mode Select

\overline{CS}	R/W	\overline{SE}	Mode
0	0	1	Single Channel Write. See Table 2.
0	0	0	Servo/Bank Write. See Table 2.
0	1	X	Single Channel Read. See Table 2.
1	X	X	Idle.

TABLE 2: Head Select*

Head Selected ($\overline{SE} = 1$)	Head Selected (servo bank write) ($\overline{SE} = 0$)	HS3	HS2	HS1	HS0
0	no heads selected	0	0	0	0
1	H0, H1	0	0	0	1
2	H2, H3	0	0	1	0
3	H0, H1, H2, H3	0	0	1	1
4	no heads selected	0	1	0	0
5	H4, H5	0	1	0	1
6	H6, H7,	0	1	1	0
7	H4, H5, H6, H7	0	1	1	1
8	no heads selected	1	0	0	0
9	H8, H9	1	0	0	1

*Do not use invalid Head Select combinations.

SSI32R2100R/2101R/2102R

10 Channel Thin Film

Read/Write Devices

3

WRITE MODE

Taking both \overline{CS} and R/\overline{W} low selects write mode which configures the SSI 32R2100R/2101R/2102R as a current switch and activates the Write Unsafe (WUS) detector circuitry. On the 32R2100R, head current is toggled between the X and Y side of the selected head on each low to high transition of \overline{WD} . On the 32R2101R, head current is toggled between the X and Y side of the selected head on each high to low transition of the Write Data Input (WDI). Note that a preceding Read to Write transition or Idle to Write transition initializes the Write Data Flip-Flop to pass write current into the "X" side of the device. In this case, the Y side is higher potential than the X side. With the 32R2102R, head current is toggled between the X and Y side of the head on each \overline{WDX} – \overline{WDY} transition. When the potential of \overline{WDX} is higher than \overline{WDY} , the potential on the X side of the head is higher than the Y side (HNY is sinking current). The magnitude of the write current (0-pk) is given by:

$$I_w = A_w \cdot \frac{V_{wc}}{R_{wc}} = K/R_{wc}$$

where A_w is the write current gain.

R_{wc} is connected from pin WC to GND. Note the actual head current I_x, y is given by:

$$I_x, y = \frac{I_w}{1 + R_h/R_d}$$

where:

R_h = Head resistance plus external wire resistance

R_d = Damping resistance

In write mode a 250 Ω damping resistor is switched in across the Hx, Hy ports (32R2100R/2101R/2102R only). Unselected heads are at ground potential.

SERVO WRITE MODE

Taking \overline{SE} low and R/\overline{W} low activates servo write mode. This mode allows for writing to multiple channels at once, which is useful during servo formatting. In this mode, the bank of channels will be selected according to Table 2.

In order to properly activate servo write mode, the \overline{SE} pin must be pulled low at least 20 ns before R/\overline{W} is pulled low. This is a safety feature to prevent glitches on the \overline{SE} pin from affecting normal write mode.

POWER SUPPLY FAULT PROTECTION

A voltage fault detection circuit improves data security by disabling the write current generator during a voltage fault or power startup regardless of mode.

HEAD SHORT TO GROUND PROTECTION

The SSI 32R2100R/2101R/2102R provides a head short to ground protection circuit in any mode. In idle or read mode, or for an unselected head in write mode, current out of the head port will not exceed 3 mA. If a selected head in write mode is shorted to ground, the write current generator will turn off, and remain off until the user exits write mode and then returns to write mode.

WRITE UNSAFE

Any of the following conditions will be indicated as a high level on the Write Unsafe, WUS, open collector output.

- WDI frequency too low
- Device in read mode
- Device not selected
- Device in servo write mode
- No head current
- Open head
- Head short to ground
- Power supply fault

To prevent false WUS flags, the head inductance and resistance should be less than 1 μ H and 50 Ω , respectively.

WDI frequency too low is detected if the WDI frequency falls below 1 MHz (typ). Consult the WUS Safe to Unsafe timing for range of frequency detection.

Device in read mode, Device in servo write mode and Device not selected will flag WUS if R/\overline{W} is high, if \overline{SE} is low, or \overline{CS} is high.

No head current will flag WUS if $R_{wc} > 50$ k Ω .

Head opened will flag WUS if $R_h = \infty$. To prevent false WUS flags, the open head detect is disabled when write data frequency is greater than 20 MHz.

Head short to ground is described in the preceding paragraph.

Upon entering write mode, WUS is valid within the specified R/\overline{W} timing.

After the low frequency fault condition is removed, one positive transition of \overline{WD} (32R2100R) one positive transition of \overline{WDX} – \overline{WDY} (32R2102R) or one negative transition of WDI (32R2101R) is required to clear WUS.

SSI32R2100R/2101R/2102R

10 Channel Thin Film

Read/Write Devices

READ MODE

The read mode configures the SSI 32R2100R/2101R/2102R as a low noise differential amplifier and deactivates the write current generator. The damping resistor is switched out of the circuit allowing a high impedance input to the read amplifier. The RDX and RDY output are driven by emitter followers. They should be AC coupled to the load. The HnX, HnY inputs are non-inverting to the RDX, RDY outputs.

Note that in idle or write mode, the read amplifier is deactivated and RDX, RDY outputs become high impedance. This facilitates multiple R/W applications

(wired-OR RDX, RDY) and minimizes voltage change when switching from write to read mode. Note also that the write current source is deactivated for both the read and idle mode.

In read mode, unselected heads are at ground potential.

IDLE MODE

Taking \overline{CS} high selects the idle mode which switches the RDX and RDY outputs into a high impedance state and deactivates the device. Power consumption in this mode is held to a minimum.

In idle mode, all heads are at ground potential.

PIN DESCRIPTION

CONTROL/STATUS († When more than one Read/Write device is used, signals can be wire OR'ed.)

NAME	TYPE	DESCRIPTION
\overline{CS}	I	Chip Select Input. A logical low level enables the device.
R/\overline{W} †	I	Read/Write. A logical high level enables read mode. A logical low level enables write mode.
\overline{SE}	I	Servo Enable. A low level enables servo bank write mode. See Servo Enable section.
HS0, HS1, HS2, HS3	I	Head Select. Decoded address selects one of 10 channels. See Table 2.
WUS†	O	Write Unsafe. A high level indicates an unsafe writing condition. See WUS section.
WC†	I	Write Current. Sets the write current through the recording head.

HEAD TERMINAL CONNECTIONS

H0X-H9X H0Y-H9Y	I	X,Y Head Connections
--------------------	---	----------------------

DATA INPUT/OUTPUT

WDI†	I	Write Data In. A negative transition of WDI changes the direction of current in the recording head. (32R2101R)
WD, \overline{WD} †	I	Differential Write Data In. A positive transition of WD- \overline{WD} changes the direction of current in the recording head. (32R2100R)
RDX, RDY†	O	Differential Read Data Out. Emitter follower output.
WDX, WDY	I	Differential write data In. Each transition of WDX-WDY changes the direction of current in the current in the recording head. (32R2102R)

SSI32R2100R/2101R/2102R

10 Channel Thin Film Read/Write Devices

PIN DESCRIPTION (continued)

POWER

VCC	I	5V power supply
VDD	I	12V power supply
GND	I	Ground

ELECTRICAL SPECIFICATIONS

Current maximums are currents with the highest absolute value.

ABSOLUTE MAXIMUM RATINGS

Operation beyond the maximum ratings may damage the device.

PARAMETER		RATING	
DC Supply Voltage	VCC	-0.3 to 6 Vdc	
	VDD	-0.3 to 14.0 Vdc	
Write Current	I _w	100 mA	
Digital Input Voltage	V _{in}	-0.3 to VCC + 0.3V	
Head Port Voltage	V _H	-0.3 to VDD + 0.3V	
WUS Pin Voltage	V _{wus}	-0.3 to VCC + 2V	
Output Current	RDX,RDY	I _o	-6 mA
	WUS	I _{wus}	12 mA
Junction Operating Temperature	T _j	125°	
Storage Temperature		-65 to 150°	

RECOMMENDED OPERATING CONDITIONS

DC Supply Voltage	VCC	5 ± 10%V
	VDD	12 ± 10%V
Ambient Operating Temperature	T _a	0° < T _a < 75°
Head Inductance	L _h	L _h < 1 μH
Head Resistance, Valid WUS	R _h	R _h < 50Ω

TEST CONDITIONS

Recommended operating conditions apply.

Write Current, I _w	20 mA
Head Inductance, L _h	1 μH
Head Resistance, R _h	30Ω
WD Frequency	5 MHz
WD, $\overline{\text{WD}}$ rise/fall time (32R2100/2100R)	1 ns
WDI rise/fall time (32R2101/2101R)	1 ns

SSI32R2100R/2101R/2102R

10 Channel Thin Film

Read/Write Devices

ELECTRICAL SPECIFICATIONS (continued)

POWER DISSIPATION

Recommended operating conditions apply.

PARAMETER	CONDITION	MIN	NOM	MAX	UNIT
VCC Supply Current	read mode		46	75	mA
	write mode		20	29	mA
VCC Supply Current	SBW mode (4 heads)		50	65	mA
	idle mode		0.6	1	mA
VDD Supply Current	read mode		0.4	0.7	mA
	write mode		$lw + 7$	$lw + 12$	mA
VDD Supply Current	SBW mode (4 heads)		$28 + 4 \cdot lw$	$40 + 4 \cdot lw$	mA
	idle mode		0.3	0.6	mA
Power Dissipation	read mode		235	340	mW
	write mode		$(184 \text{ mW}) + (lw \times VDD)$	$(253 \text{ mW}) + (lw \times VDD)$	mW
Total Power Dissipation	SBW mode (4 heads)		$645 + 4 \cdot lw \cdot VDD$	$886 + 4 \cdot lw \cdot VDD$	mA
	idle mode		6.6	13	mW

*Limit servo mode supplies to $4.5V \leq VCC \leq 5V$ and $10.8V \leq VDD \leq 12V$.

DIGITAL INPUTS

Input High Voltage HSX, CS, R/W, SE, WDI	Vih		2		VDC	
Input Low Voltage HSX, CS, R/W, SE, WDI	Vil			0.8	VDC	
Input High Current HSX, CS, R/W, SE, WDI	Iih	Vih = 2V		100	μA	
Input Low Current HSX, CS, R/W, SE, WDI	Iil	Vil = 0.8V	-400		μA	
(WD/W \bar{D}) and (WDX/WDY) Input High Voltage	Vih		2	Vcc-0.2	VDC	
(WD/W \bar{D}) and (WDX/WDY) Input Low Voltage	Vil		Vih-2	Vih-0.3	VDC	
(WD/W \bar{D}) and (WDX/WDY) Input Voltage Difference			0.3	2	V	
(WD/W \bar{D}) and (WDX/WDY) Input High Current		Vih = Vcc-0.75V		85	110	μA
(WD/W \bar{D}) and (WDX/WDY) Input Low Current		Vih = Vcc-1.75V		70	100	μA

SSI32R2100R/2101R/2102R

10 Channel Thin Film Read/Write Devices

DIGITAL OUTPUTS

WUS Output Low Voltage	Vol	Iol = 2 mA max			0.5	VDC
WUS Output High Current	Ioh	Voh = Vcc	-100	0	100	μA

WRITE CHARACTERISTICS

Test conditions apply unless otherwise specified.

PARAMETER	CONDITION	MIN	NOM	MAX	UNIT	
Write Current Voltage	Vwc		2		V	
Write Current Gain	Awc	Iw = Aw•Vwc/Rwc	25		mA/mA	
Write Current Constant "K"		Iw = K/Rwc	45	50	55	mA • kΩ
Differential Head Voltage Swing	Open Head, Iw = 20 mA	11	13		Vp-p	
Head Differential	Rd	32R2100R/2101R/2102R	200	250	300	Ω
Load Resistance		32R2100/2101/2102	1000	1500	2000	Ω
WD Pulse Width	PWH	5			ns	
	PWL	5			ns	
Unselected Head Voltage				0.1	VDC	
Unselected Head Current				0.2	mA	
VCC Fault Voltage	Iw ≤ 0.2 mA	3.9	4.1	4.3	V	
VDD Fault Voltage	Iw ≤ 0.2 mA	8.5	9.3	10	V	
Head Current	HnX, HnY	VCC, VDD low voltage fault condition	-0.2		0.2	mA

SERVO WRITE CHARACTERISTICS

Write Current Range		10		20	mA
Write Current Matching	Between channels		±10%		

READ CHARACTERISTICS

Test conditions apply unless otherwise specified. CL (RDX, RDY) < 20 pF, RL (RDX, RDY) = 1 kΩ.

Differential Voltage Gain		Vin = 1 mVp-p @1 MHz 32R2100RU/2101/2102RU	120	150	180	V/V
		32R2100RW/2101/2102/RW	210	250	290	V/V
Voltage BW	-1 dB	Zs < 5Ω, Vin = 1 mVp-p	45			MHz
	-3 dB		85			MHz
Input Noise Voltage		BW = 20 MHz, Lh = 0, Rh = 0		0.45	0.63	nV/√Hz
Input Noise Current		BW = 20 MHz, Lh = 0, Rh = 0		4	10	pA/√Hz
Differential Input Capacitance		Vin = 1 mVp-p, f = 5 MHz		10	14	pF
Differential Input Resistance		Vin = 1 mVp-p, f = 5 MHz 32R2100/2101/2102	450	750	1800	Ω
		32R2100R/2101R/2102R	450	750	1800	Ω

SSI32R2100R/2101R/2102R

10 Channel Thin Film

Read/Write Devices

READ CHARACTERISTICS (continued)

Test conditions apply unless otherwise specified. CL (RDX, RDY) < 20 pF, RL (RDX, RDY) = 1 kΩ.

PARAMETER	CONDITION	MIN	NOM	MAX	UNIT
Dynamic Range	AC input voltage where gain falls to 90% of its small signal gain value, f = 5 MHz	2	4		mVp-p
Common Mode Rejection Ratio	Vin = 0 VDC + 100 mVp-p @ 5 MHz	50	60		dB
Power Supply Rejection Ratio	100 mVp-p @ 5 MHz on VCC	50	70		dB
Channel Separation	Unselected channels driven with Vin = 0 VDC + 100 mVp-p	50	60		dB
Output Offset Voltage	AV = 150 Lh = 0, Rh = 0	-190		190	mV
	AV = 250 Lh = 0, Rh = 0	-250		250	mV
Single Ended Output Resistance	f = 5 MHz		30		Ω
Output Current	Peak to Peak AC coupled load, RDX to RDY	3	5		mA
RDX, RDY Common Mode Output Voltage			Vcc-2.2		VDC

SWITCHING CHARACTERISTICS

Test conditions apply unless otherwise specified.

R/W	Read to Write	R/W to 90% of write current			0.15	μs
	Write to Read	R/W to 90% of 100 mV Read signal envelope			0.20	μs
CS	Unselect to Select	CS to 90% of 100 mV 10 MHz Read signal envelope			0.20	μs
	Select to Unselect	CS to 10% of write current			0.15	μs
HS0,1, 2, 3 to any Head		To 90% of 100 mV 10 MHz Read signal envelope			0.15	μs
WUS	Safe to Unsafe (TD1)	Write mode, loss of WD transitions; Defines max WD period for WUS operation	0.6	2	3.6	μs
	Unsafe to Safe (TD2)	Fault cleared: from first WD transition		0.1	0.2	μs
WDI	Frequency Range	Valid WUS	1		100	MHz
Head Current		Lh = 0, Rh = 0				
(WD/WD) and (WDX/WDY) to lx - ly (TD3)	WDI to lx - ly (TD3)	50% to 50%		3	5	ns
	WDI to lx - ly (TD3)	1.5V to 50%		4	6	ns
	Asymmetry	WD has 1 ns rise/fall time			0.5	ns
	Rise/fall Time	10% to 90% points Iw = 20 mA, Rh = 0, Lh = 0 Iw = 20 mA, Rh = 20Ω, Lh = 600 nH			3	ns
					7	ns

SSI32R2100R/2101R/2102R 10 Channel Thin Film Read/Write Devices

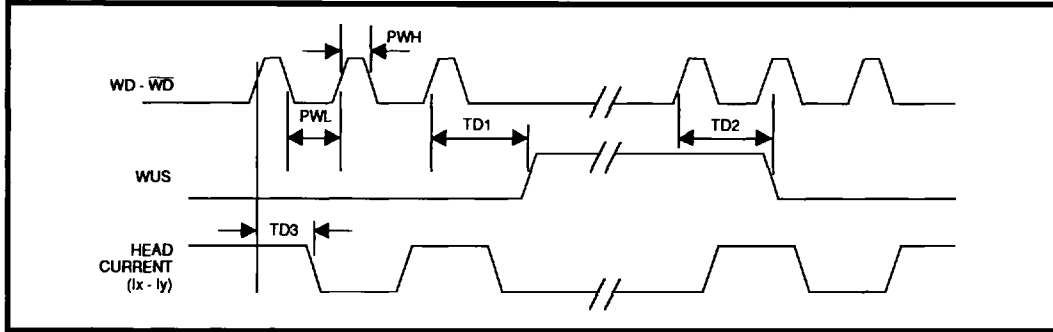

FIGURE 1: Write Mode Timing Diagram (32R2100R)

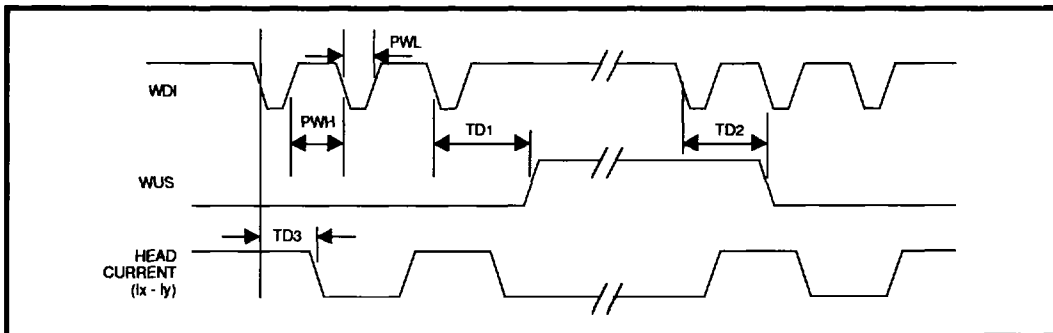

FIGURE 2: Write Mode Timing Diagram (32R2101R)

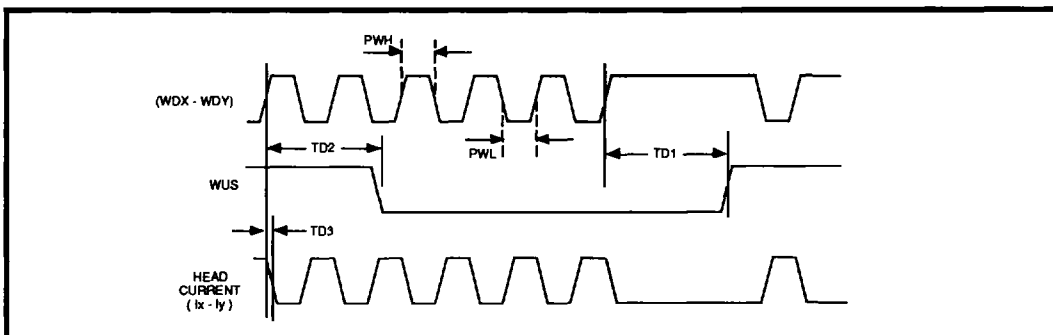

FIGURE 3: Write Mode Timing Diagram (32R2102R)

3

SSI32R2100R/2101R/2102R

10 Channel Thin Film

Read/Write Devices

PACKAGE PIN DESIGNATIONS

(Top View)

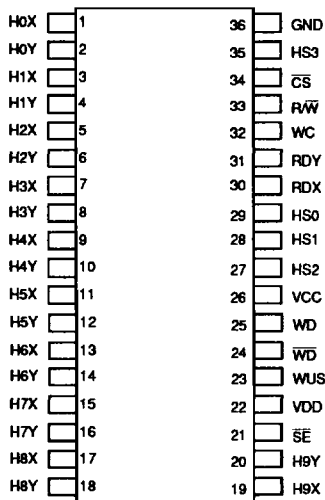

SSI 32R2100R
36-Lead, PECL Input
10-Channel SOM

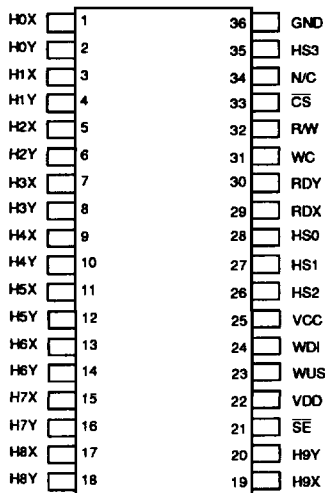

SSI 32R2101R
36-Lead, TTL Input
10-Channel SOM

CAUTION: Use handling procedures necessary for a static sensitive component.

SSI32R2100R/2101R/2102R

10 Channel Thin Film Read/Write Devices

PACKAGE PIN DESIGNATIONS (Top View)

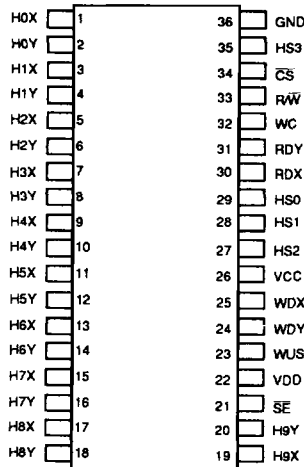

SSI 32R2102R 36-Lead, PECL Input Without Flip-Flop 10-Channel SOM

CAUTION: Use handling procedures necessary for a static sensitive component.

ORDERING INFORMATION

PART DESCRIPTION		ORDER NUMBER	PACKAGE MARK
SSI 32R2100R	36-Lead PECL input	32R2100RU-10CM	32R2100RU-10
SSI 32R2101R	36-Lead TTL input	32R2101RU-10CM	32R2101RU-10
SSI 32R2102R	36-Lead PECL input without Flip Flop	32R2102RU-10CM	32R2102RU-10

No responsibility is assumed by Silicon Systems for use of this product nor for any infringements of patents and trademarks or other rights of third parties resulting from its use. No license is granted under any patents, patent rights or trademarks of Silicon Systems. Silicon Systems reserves the right to make changes in specifications at any time without notice. Accordingly, the reader is cautioned to verify that the data sheet is current before placing orders.

Silicon Systems, Inc., 14351 Myford Road, Tustin, CA 92680-7022 (714) 573-6000, FAX (714) 573-6914