

Features

- Generates clocks for OC-3, STM-1, DS3, E3, DS2, DS1, E1, 19.44 MHz and ST-BUS
- Meets jitter generation requirements for STM-1, OC-3, DS3, E3, J2 (DS2), E1 and DS1 interfaces
- Compatible with GR-253-CORE SONET stratum 3 and G.813 SEC timing compliant clocks
- Provides "hit-less" reference switching
- Detects frequency of both reference clocks and synchronizes to any combination of 8 kHz, 1.544 MHz, 2.048 MHz and 19.44 MHz reference frequencies
- Continuously monitors both references for frequency accuracy exceeding ± 12 ppm
- Holdover accuracy of 70×10^{-12} meets GR-1244 Stratum 3E and ITU-T G.812 requirements
- Meets requirements of G.813 Option 1 for SDH Equipment Clocks (SEC) and GR-1244 for Stratum 4E and Stratum 4 Clocks
- 3.3V power supply

Applications

- Line Card synchronization for SDH, SONET, DS3, E3, J2 (DS2), E1 and DS1 interfaces
- Timing card synchronization for SDH and PDH Network Elements

Ordering Information

ZL30410QCC 80 Pin LQFP

-40°C to 85°C

- Clock generation for ST-BUS and GCI timing

Description

The ZL30410 is a Multi-service Line Card Phase-Locked Loop designed to generate multiple clocks for SONET, SDH and PDH equipment including timing for ST-BUS and GCI interfaces.

The ZL30410 operates in NORMAL (LOCKED), HOLDOVER and FREE-RUN modes to ensure that in the presence of jitter and interruptions to the reference signals, the generated clocks meet international standards. The filtering characteristics of the PLL are hardware pin selectable and they do not require any external adjustable components. The ZL30410 uses an external 20 MHz Master Clock Oscillator to provide a stable timing source for the HOLDOVER operation.

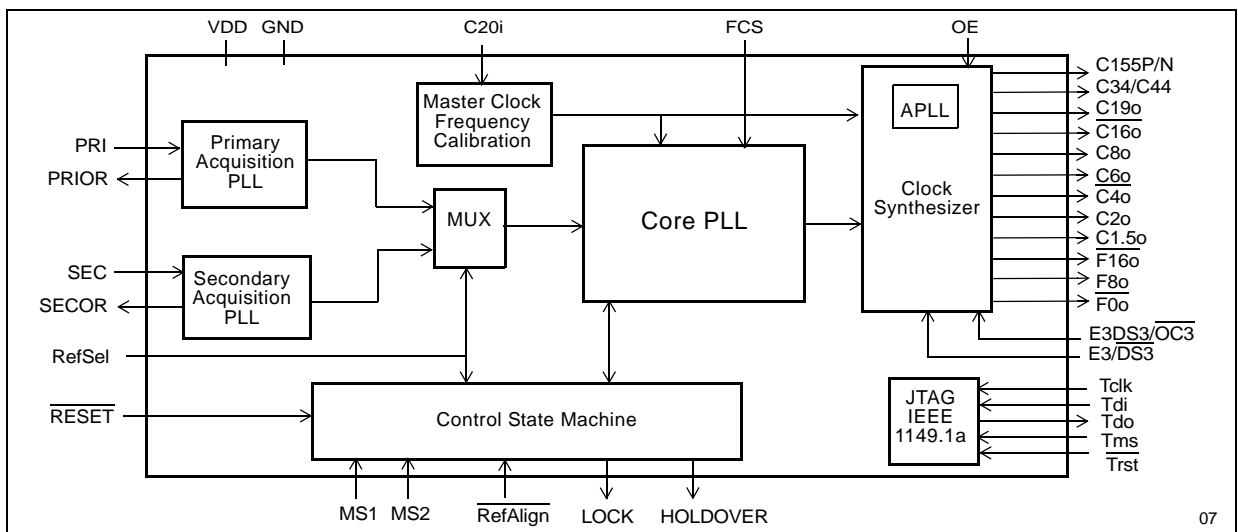

Figure 1 - Functional Block Diagram

Zarlink Semiconductor US Patent No. 5,602,884, UK Patent No. 0772912,
 France Brevete S.G.D.G. 0772912; Germany DBP No. 69502724.7-08

Table of Contents

1.0 ZL30410 Pinout	3
1.1 Pin Connections	3
2.0 Functional Description	8
2.1 Acquisition PLLs	8
2.2 Core PLL	8
2.2.1 Digitally Controlled Oscillator (DCO)	9
2.2.2 Filters	9
2.2.3 Lock Indicator (LOCK)	9
2.2.4 Reference Alignment (RefAlign)	9
2.3 Clock Synthesizer	10
2.3.1 Output Clocks	10
2.4 Control State Machine	11
2.4.1 Clock Modes	11
2.4.2 ZL30410 State Machine	11
2.4.3 State Transitions	13
2.5 JTAG Interface	14
3.0 Control Interface	14
3.1 Control Pins	14
3.2 Status Pins	15
4.0 Applications	16
4.1 ZL30410 Switching Between Clock Modes	16
4.1.1 System Start-up Sequence: FREE-RUN --> HOLDOVER --> NORMAL	16
4.1.2 Single Reference Operation: NORMAL --> AUTO HOLDOVER --> NORMAL	17
4.1.3 Single 8 kHz Reference Operation: NORMAL --> AUTO HOLDOVER--> HOLDOVER --> NORMAL	18
4.1.4 Dual Reference Operation: NORMAL --> AUTO HOLDOVER--> HOLDOVER --> NORMAL	19
4.1.5 Reference Switching (RefSel): NORMAL --> HOLDOVER --> NORMAL	20
4.2 Power supply filtering	21
5.0 Characteristics	22
5.1 AC and DC Electrical Characteristics	22
5.2 Performance Characteristics	29

1.0 ZL30410 Pinout

1.1 Pin Connections

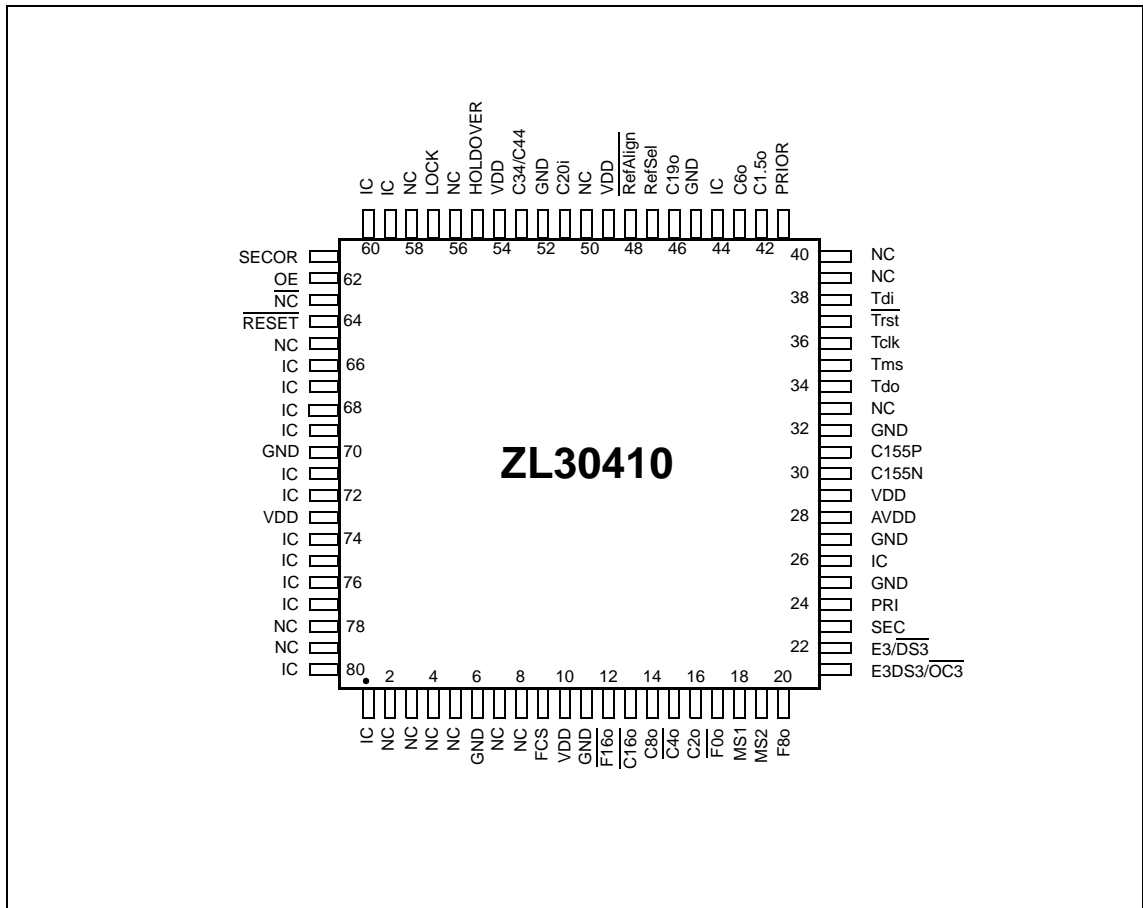

Figure 2 - Pin Connections for 80-pin LQFP package

Pin Description

Pin #	Name	Description
1	IC	Internal Connection. Leave unconnected.
2-5	NC	No internal bonding Connection. Leave unconnected.
6	GND	Ground. Negative power supply.
7, 8	NC	No internal bonding Connection. Leave unconnected.
9	FCS	Filter Characteristic Select (Input). In Hardware Control, FCS selects the filtering characteristics of the ZL30410. Set this pin high to have a loop filter corner frequency of 6 Hz and limit the phase slope to 41 ns per 1.326 ms. Set this pin low to have corner frequency of 12 Hz with no phase slope limiting imposed. This pin is internally pulled down to GND.
10	VDD	Positive Power Supply.
11	GND	Ground.
12	$\overline{F160}$	Frame Pulse ST-BUS 8.192 Mb/s (CMOS tristate output). This is an 8 kHz, 61ns wide, active low framing pulse, which marks beginning of a ST-BUS frame. This frame pulse is typically used for ST-BUS operation at 8.192 Mb/s.
13	$\overline{C160}$	Clock 16.384 MHz (CMOS tristate output). This clock is used for ST-BUS operation at 8.192 Mb/s.
14	C80	Clock 8.192 MHz (CMOS tristate output). This clock is used for ST-BUS operation at 8.192 Mb/s.
15	$\overline{C40}$	Clock 4.096 MHz (CMOS tristate output). This clock is used for ST-BUS operation at 2.048 Mb/s.
16	C20	Clock 2.048 MHz (CMOS tristate output). This clock is used for ST-BUS operation at 2.048 Mb/s.
17	$\overline{F00}$	Frame Pulse ST-BUS 2.048 Mb/s (CMOS tristate output). This is an 8 kHz, 244ns, active low framing pulse, which marks the beginning of a ST-BUS frame. This is typically used for ST-BUS operation at 2.048 Mb/s and 4.096 Mb/s.
18	MS1	Mode Select 1 (Input). The MS1 and MS2 pins select the ZL30410 mode of operation (Normal, Holdover or Free-run), see Table 1 on page 14 for details. The logic level at this input is sampled by the rising edge of the F80 frame pulse.
19	MS2	Mode Select 2 (Input). The MS2 and MS1 pins select the ZL30410 mode of operation (Normal, Holdover or Free-run), see Table 1 on page 14 for details. The logic level at this input is sampled by the rising edge of the F80 frame pulse.
20	F80	Frame Pulse ST-BUS/GCI 8.192 Mb/s (CMOS tristate output). This is an 8 kHz, 122 ns, active high framing pulse, which marks the beginning of a ST-BUS/GCI frame. This is typically used for ST-BUS/GCI operation at 8.192 Mb/s. See Figure 15 for details.

Pin Description (continued)

Pin #	Name	Description
21	E3DS3/ $\overline{\text{OC3}}$	E3DS3 or OC3 Selection (Input). In Hardware Control, a logic low on this pin enables the C155P/N outputs (pin 30 and pin 31) and sets the C34/C44 output (pin 53) to provide C8 or C11 clocks. Logic high at this input disables the C155 clock outputs (high impedance) and sets C34/C44 output to provide C34 and C44 clocks.
22	E3/ $\overline{\text{DS3}}$	E3 or DS3 Selection (Input). In Hardware Control, when the E3DS3/ $\overline{\text{OC3}}$ pin is set high, logic low on E3/ $\overline{\text{DS3}}$ pin selects a 44.736 MHz clock on C34/C44 output and logic high selects 34.368 MHz clock. When E3DS3/ $\overline{\text{OC3}}$ pin is set low, logic low on E3/ $\overline{\text{DS3}}$ pin selects 11.184 MHz clock on C34/C44 output and logic high selects 8.592 MHz clock.
23	SEC	Secondary Reference (Input). This input is used as a secondary reference source for synchronization. The ZL30410 can synchronize to the falling edge of the 8 kHz, 1.544 MHz or 2.048 MHz clocks and the rising edge of the 19.44 MHz clock. In Hardware Control, selection of the input reference is based upon the RefSel control input. This pin is internally pulled up to VDD.
24	PRI	Primary Reference (Input). This input is used as a primary reference source for synchronization. The ZL30410 can synchronize to the falling edge of the 8 kHz, 1.544 MHz or 2.048 MHz clocks and the rising edge of the 19.44 MHz clock. In Hardware Control, selection of the input reference is based upon the RefSel control input. This pin is internally pulled up to VDD.
25	GND	Ground.
26	IC	Internal Connection. Leave unconnected.
27	GND	Ground.
28	AVDD	Positive Analog Power Supply. Connect this pin to VDD.
29	VDD	Positive Power Supply.
30 31	C155N C155P	Clock 155.52MHz (LVDS output). Differential outputs for the 155.52 MHz clock. These outputs are enabled by applying logic low to E3DS3/ $\overline{\text{OC3}}$ input or they can be disabled by applying logic high. In the disabled state the LVDS outputs are internally terminated with an integrated 100 Ω resistor (two 50 Ω resistors connected in series). The middle point of these resistors is internally biased from a 1.25V LVDS bias source.
32	GND	Ground.
33	NC	No internal bonding Connection. Leave unconnected.
34	Tdo	IEEE1149.1a Test Data Output (CMOS output). JTAG serial data is output on this pin on the falling edge of Tclk clock. If not used, this pin should be left unconnected.
35	Tms	IEEE1149.1a Test Mode Selection (3.3 V input). JTAG signal that controls the state transition on the TAP controller. This pin is internally pulled up to VDD. If not used, this pin should be left unconnected.

Pin Description (continued)

Pin #	Name	Description
36	Tclk	IEEE1149.1a Test Clock Signal (5 V tolerant input). Input clock for the JTAG test logic. If not used, this pin should be pulled up to VDD.
37	$\overline{\text{Trst}}$	IEEE1149.1a Reset Signal (3.3 V input). Asynchronous reset for the JTAG TAP controller. This pin should be pulsed low on power-up to ensure that the device is in the normal functional state. This pin is internally pulled up to VDD. If this pin is not used then it should be connected to GND.
38	Tdi	IEEE1149.1a Test Data Input (3.3 V input). Input for JTAG serial test instructions and data. This pin is internally pulled up to VDD. If not used, this pin should be left unconnected.
39	NC	No internal bonding Connection. Leave unconnected.
40	NC	No internal bonding Connection. Leave unconnected.
41	PRIOR	Primary Reference Out of Range (Output). Logic high at this pin indicates that the Primary Reference is off the PLL centre frequency by more than $\pm 12\text{ppm}$. See PRIOR pin description in Section 3.2 on page 15 for details.
42	C1.5o	Clock 1.544 MHz (CMOS tristate output). This output provides a 1.544 MHz DS1 rate clock.
43	C6o	Clock 6.312 MHz (CMOS tristate output). This output provides a 6.312 MHz DS2 rate clock.
44	IC	Internal Connection. Connect this pin to Ground.
45	GND	Ground.
46	C19o	Clock 19.44 MHz (CMOS tristate output). This output provides a 19.44 MHz clock.
47	RefSel	Reference Source Select (Input). A logic low selects the PRI (primary) reference source as the input reference signal and logic high selects the SEC (secondary) input. The logic level at this input is sampled at the rising edge of F8o. This pin is internally pulled down to GND.
48	$\overline{\text{RefAlign}}$	Reference Alignment (Input). In Hardware Control pulling this pin low for 250 μs initiates phase realignment between the input reference and the generated output clocks. See Section 2.2.4 on page 9 for details. This pin should never be tied low permanently. Internally this pin is pulled down to GND.
49	VDD	Positive Power Supply.
50	NC	No internal bonding Connection. Leave unconnected.
51	C20i	Clock 20 MHz (5 V tolerant input). This pin is the input for the 20MHz Master Clock Oscillator. The clock oscillator should be connected directly (not AC coupled) to the C20i input and it must supply clock with duty cycle that is not worse than 40/60%.
52	GND	Digital Ground.

Pin Description (continued)

Pin #	Name	Description
53	C34/C44	Clock 34.368 MHz / clock 44.736 MHz (CMOS Output). This clock is programmable to be either 34.368 MHz (for E3 applications) or 44.736 MHz (for DS3 applications) when $\overline{\text{E3DS3/OC3}}$ is high, or to be either 8.592 MHz or 11.184 MHz when $\overline{\text{E3DS3/OC3}}$ is low. See description of $\overline{\text{E3DS3/OC3}}$ and $\overline{\text{E3/DS3}}$ inputs for details.
54	VDD	Positive Power Supply.
55	HOLDOVER	Holdover Indicator (CMOS output). Logic high at this output indicates that the device is in Holdover mode.
56	NC	No internal bonding Connection. Leave unconnected.
57	LOCK	Lock Indicator (CMOS output). Logic high at this output indicates that ZL30410 is locked to the input reference. See LOCK indicator description in Section 2.2.3, "Lock Indicator (LOCK)," on page 9.
58	NC	No internal bonding Connection. Leave unconnected.
59	IC	Internal Connection. Connect to logic high.
60	IC	Internal Connection. Connect to ground.
61	SECOR	Secondary Reference Out of Range (Output). Logic high at this pin indicates that the Secondary Reference is off the PLL centre frequency by more than ± 12 ppm. See SECOR (PRIOR) pin description in Section 3.2 on page 15 for details.
62	OE	Output Enable (Input). Logic high on this input enables C19, $\overline{\text{F16}}$, $\overline{\text{C16}}$, C8, C6, C4, C2, C1.5, F8 and F0 signals. Pulling this input low will force the output clocks pins into a high impedance state.
63	NC	No internal bonding Connection. Leave unconnected.
64	$\overline{\text{RESET}}$	RESET (5V tolerant input). The ZL30410 must be reset after power-up in order to set internal functional blocks into a default state. The internal reset is performed by forcing $\overline{\text{RESET}}$ pin low for a minimum of 1 μs after the C20 Master Clock is applied to pin C20i. This operation forces the ZL30410 internal state machine into a RESET state for a duration of 625 μs .
65	NC	No internal bonding Connection. Leave unconnected.
66-69	IC	Internal connection. Connect these pins to logic high.
70	GND	Ground.
71, 72	IC	Internal Connection (Input). Connect these pins to ground.
73	VDD	Positive Power Supply.
74 - 77	IC	Internal connection. Connect these pins to logic high.
78, 79	NC	No internal bonding Connection. Leave unconnected.
80	IC	Internal Connection (Input). Connect this pin to ground.

2.0 Functional Description

The ZL30410 is designed to provide timing for SDH and SONET equipment conforming to ITU-T, ANSI, ETSI and Telcordia recommendations. In addition, it generates clocks for SDH and PDH equipment operating at DS1, DS2, DS3, E1, and E3 rates. The ZL30410 provides clocks for industry standard ST-BUS and GCI backplanes, and it also supports H.110 timing requirements. The functional block diagram of the ZL30410 is shown in Figure 1 "Functional Block Diagram" and its operation is described in the following sections.

2.1 Acquisition PLLs

The ZL30410 has two Acquisition PLLs for monitoring availability and quality of the Primary (PRI) and Secondary (SEC) reference clocks. Each Acquisition PLL operates independently and locks to the falling edges of one of the three input reference frequencies: 8 kHz, 1.544 MHz, 2.048 MHz or to the rising edge of 19.44 MHz. The reference frequency is automatically detected by the ZL30410 device.

The Primary and Secondary Acquisition PLLs are designed to provide indication of two levels of reference clock quality. For clarity, only the Primary Acquisition PLL is referenced in the text, but the same applies to the Secondary Acquisition PLL:

- Reference frequency drifts more than ± 12 ppm. In response, the PRIOR (Primary Reference Out of Range) pin changes state to high, in conformance with Stratum 3 requirements defined in GR-1244-CORE
- Reference frequency drifts more than ± 30000 ppm or that the reference has been lost completely. In response, the Primary Acquisition PLL enters its own Holdover mode which forces the Core PLL into the Auto Holdover state.

Outputs of both Acquisition PLLs are connected to a multiplexer (MUX), which allows selection of the desired reference. This multiplexer channels binary words to the Core PLL digital phase detector (instead of analog signals) which eliminates quantization errors and improves phase alignment accuracy. The bandwidth of the Acquisition PLL is much wider than the bandwidth of the following Core PLL. This feature allows cascading Acquisition and Core PLLs without altering the transfer function of the Core PLL.

2.2 Core PLL

The most critical element of the ZL30410 is its Core PLL, which generates a phase-locked clock, filters jitter and suppresses input phase transients. All of these features are in agreement with international standards:

- G.813 Option 1 clocks for SDH equipment
- GR-1244 for Stratum 4E and 4 Clocks

When locked to a G.813 Option 1 and 2 or SONET Stratum 3 quality clock the ZL30410 generates clocks that also meet SONET Stratum 3 or G.813 Option 1 and 2 requirements.

The Core PLL supports three mandatory modes of operation: Free-run, Normal (Locked) and Holdover. Each of these modes places specific requirements on the building blocks of the Core PLL.

- In Free-run Mode, the Core PLL derives its output clock from the 20 MHz Master Clock Oscillator connected to pin C20i. The stability of the generated clocks remains the same as the stability of the Master Clock Oscillator.
- In Normal Mode, the Core PLL locks to one of the Acquisition PLLs. Both Acquisition PLLs provide preprocessed phase data to the Core PLL including detection of reference clock quality.
- In Holdover mode, the Core PLL generates a clock based on data collected from past reference signals. The Core PLL enters Holdover mode if the attached Acquisition PLL switches into the Holdover state or under external control.

Some of the key elements of the Core PLL are shown in Figure 3 "Core PLL Functional Block Diagram".

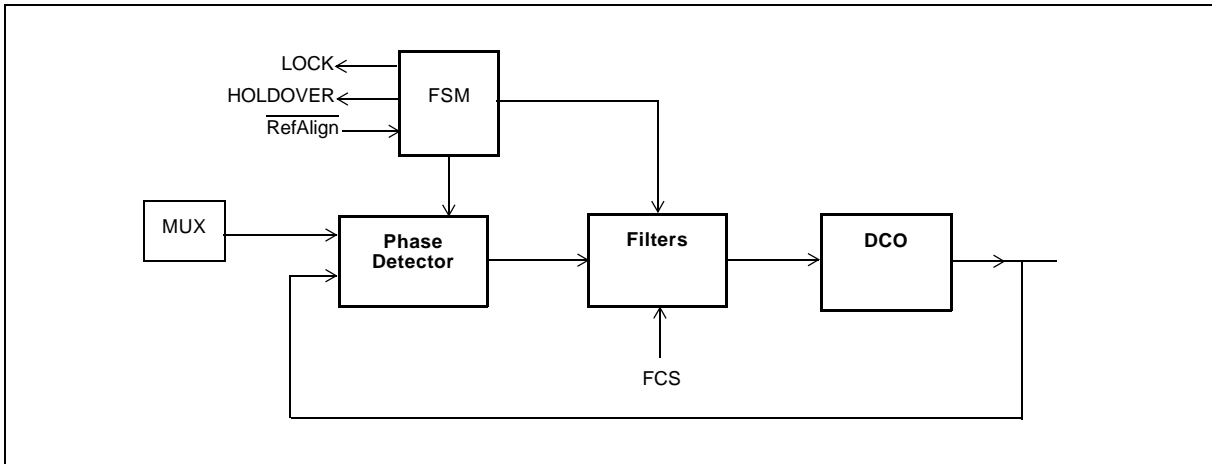

Figure 3 - Core PLL Functional Block Diagram

2.2.1 Digitally Controlled Oscillator (DCO)

The DCO is an arithmetic unit that continuously generates a stream of numbers that represent the phase-locked clock. These numbers are passed to the Clock Synthesizer (see section 2.3) where they are converted into electrical clock signals of various frequencies.

2.2.2 Filters

In Normal mode, the clock generated by the DCO is phase-locked to the input reference signal and band-limited to meet synchronization standards. The ZL30410 provides two hardware selectable (FCS pin) filtering options. The filtering characteristics are similar to a first order low pass filter with corner frequencies that support international standards:

- **6 Hz** filter: supports G.813 Option 1 Clock
- **12 Hz** filter: supports line card applications for G.812, G.813, GR-1244 and GR-253

2.2.3 Lock Indicator (LOCK)

The ZL30410 is considered locked (LOCK pin high) when the residual phase movement after declaring locked condition does not exceed 20 ns; as required by standard wander generation MTIE and TDEV tests. To ensure the integrity of the LOCK status indication, the ZL30410 holds LOCK pin low for a minimum of one second before declaring lock. The ZL30410's locking process allows it to lock within the specified locking times to references with a fractional frequency offset of up to ± 20 ppm.

2.2.4 Reference Alignment (RefAlign)

When the ZL30410 finishes locking to a reference an arbitrary phase difference will remain between its output clocks and its reference; this phase difference is part of the normal operation of the ZL30410. If so desired, the output clocks can be brought into phase alignment with the PLL reference by using the RefAlign control pin.

Using $\overline{\text{RefAlign}}$ with 1.544 MHz, 2.048 MHz or 19.44 MHz Reference

If the ZL30410 is locked to a 1.544 MHz, 2.048 MHz or 19.44 MHz reference, then the output clocks can be brought into phase alignment with the PLL reference by using the $\overline{\text{RefAlign}}$ control pin according to the following procedure:

- Wait until the ZL30410 LOCK indication is high, indicating that it is locked
- Pull $\overline{\text{RefAlign}}$ low
- Hold $\overline{\text{RefAlign}}$ low for 250 μs
- Pull $\overline{\text{RefAlign}}$ high

After initiating a reference realignment the PLL will enter Holdover mode for 200ns while aligning the internal clocks to remove static phase error. The PLL will then begin the normal locking procedure.

Using $\overline{\text{RefAlign}}$ with an 8 kHz Reference

If the ZL30410 is locked to an 8 kHz reference, then the output clocks can be brought into phase alignment with the PLL reference by using the $\overline{\text{RefAlign}}$ control pin according to the following procedure:

- Wait until the ZL30410 LOCK indication is high, indicating that it is locked
- Pull $\overline{\text{RefAlign}}$ low
- Hold $\overline{\text{RefAlign}}$ low for 3 sec
- Pull $\overline{\text{RefAlign}}$ high

After initiating a reference realignment the PLL will enter Holdover mode for 200ns while aligning the internal clocks to remove static phase error. The PLL will then begin the normal locking procedure.

2.3 Clock Synthesizer

The output of the Core PLL is connected to the Clock Synthesizer that generates twelve clocks and three frame pulses.

2.3.1 Output Clocks

The ZL30410 provides the following clocks (see Figure 15 "ST-BUS and GCI Output Timing", Figure 16 "DS1 and DS2 Clock Timing", Figure 17 "C150 and C190 Timing", and Figure 20 "E3 and DS3 Output Timing" for details):

- C1.5o : 1.544 MHz clock with nominal 50% duty cycle
- C2o : 2.048 MHz clock with nominal 50% duty cycle
- $\overline{\text{C4o}}$: 4.096 MHz clock with nominal 50% duty cycle
- C6o : 6.312 MHz clock with nominal 50% duty cycle
- C8o : 8.192 MHz clock with nominal 50% duty cycle
- C8.5o : 8.592 MHz clock with duty cycle from 30 to 70%.
- C11o : 11.184 MHz clock with duty cycle from 30 to 70%.
- $\overline{\text{C16o}}$: 16.384 MHz clock with nominal 50% duty cycle
- C19o : 19.44 MHz clock with nominal 50% duty cycle
- C34o : 34.368 MHz clock with nominal 50% duty cycle
- C44o : 44.736 MHz clock with nominal 50% duty cycle

- C155 : 155.52 MHz clock with nominal 50% duty cycle.

The ZL30410 provides the following frame pulses (see Figure 15 "ST-BUS and GCI Output Timing" for details). All frame pulses have the same 125µs period (8kHz frequency):

- $\overline{F0o}$: 244 ns wide, logic low frame pulse
- F8o : 122 ns wide, logic high frame pulse
- $\overline{F16o}$: 61 ns wide, logic low frame pulse

The combination of two pins, $E3DS3/\overline{OC3}$ and $E3/\overline{DS3}$, controls the selection of different clock configurations. When the $E3DS3/\overline{OC3}$ pin is high then the C155o (155.52 MHz) clock is disabled and the C34/44 clock is output at its nominal frequency. The logic level on the $E3/\overline{DS3}$ input determines if the output clock on the C34/44 output is 34.368 MHz (E3) or 44.736 MHz (DS3) (see Figure 4, "C34/C44, C155o Clock Generation Options," on page 11 for details).

		C34/44 Output		C155 Output	
		$E3DS3/\overline{OC3}$		$E3DS3/\overline{OC3}$	
		0	1	0	1
$E3/\overline{DS3}$	0	11.184	44.736	155.52 active	disabled
	1	8.592	34.368		

Figure 4 - C34/C44, C155o Clock Generation Options

All clocks and frame pulses (except the C155) are output with CMOS logic levels. The C155 clock (155.52 MHz) is output in a standard LVDS format.

2.4 Control State Machine

2.4.1 Clock Modes

The ZL30410 supports three Clock Modes: Free-run, Normal (Locked) and Holdover. All Clock Modes are defined in the international standards e.g.: G.813, GR-1244-CORE and GR-253-CORE and they are supported by a corresponding state in the ZL30410 Control State Machine.

2.4.2 ZL30410 State Machine

The ZL30410 Control State Machine is a combination of many internal states supporting the three mandatory clock modes: Free-run, Normal and Holdover. A simplified state machine diagram that is shown in Figure 5 includes these three states which are complemented by two additional states: Reset and Auto Holdover. These two additional states are critical to the ZL30410 operation under changing external conditions.

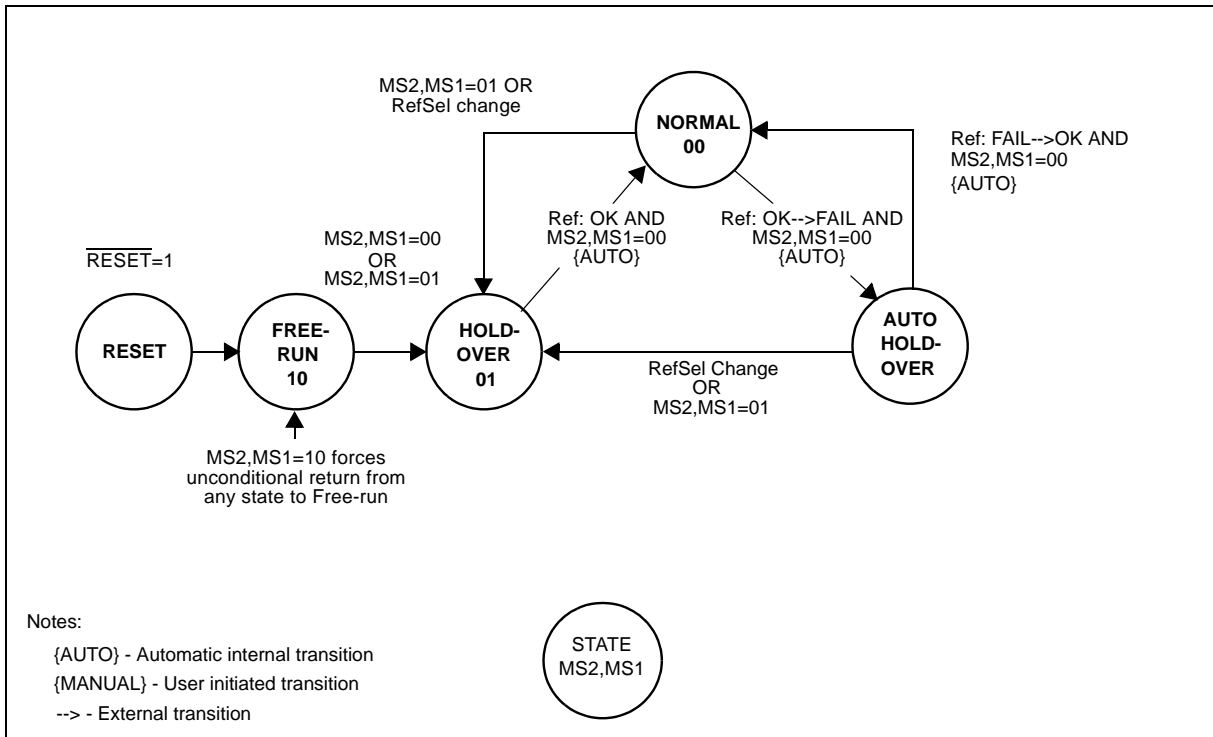

Figure 5 - ZL30410 State Machine

Reset State

The Reset State must be entered when ZL30410 is powered-up. In this state, all arithmetic calculations are halted, and clocks are stopped. The Reset state is entered by pulling the $\overline{\text{RESET}}$ pin low for a minimum of $1\mu\text{s}$. When the $\overline{\text{RESET}}$ pin is pulled back high, internal logic starts a $625\mu\text{s}$ initialization process before switching into the Free-run state ($\text{MS}_2, \text{MS}_1 = 10$).

Free-Run State (Free-Run mode)

The Free-run state is entered when synchronization to a network reference is not possible or is not required. Typically this occurs during installation or maintenance. In the Free-run state, the accuracy of the generated clocks is determined by the accuracy and stability of the ZL30410 Master Crystal Oscillator.

Normal State (Normal Mode or Locked Mode)

The Normal State is entered when a good quality reference clock from the network is available for synchronization. The ZL30410 automatically detects the frequency of the reference clock (8 kHz, 1.544 MHz, 2.048 MHz or 19.44 MHz) and sets the LOCK status pin high after acquiring synchronization. In the Normal state all generated clocks ($\text{C}1.5_0$, $\text{C}2_0$, $\text{C}4_0$, $\text{C}6_0$, $\text{C}8_0$, $\text{C}16_0$, $\text{C}19_0$, $\text{C}34/\text{C}44$ and $\text{C}155$) and frame pulses ($\text{F}0_0$, $\text{F}8_0$, $\text{F}16_0$) are synchronized to the master timing card. To guarantee uninterrupted synchronization, the ZL30410 has two Acquisition PLLs that continuously monitor the quality of the incoming reference clocks. This dual architecture enables quick replacement of a poor or failed reference and minimizes the time spent in other states.

Holdover State (Holdover Mode)

The Holdover State is typically entered for a short duration while synchronization with the network is temporarily disrupted. In Holdover Mode, the ZL30410 generates clocks, which are not locked to an external reference signal but their frequencies are based on stored coefficients in memory that were determined while the PLL was in Normal Mode and locked to an external reference signal.

The initial frequency offset of the ZL30410 in Holdover Mode is 70×10^{-12} . This is more accurate than Telcordia's GR-1244-CORE Stratum 3E requirement of $\pm 1 \times 10^{-9}$. When the ZL30410 is transitioned into Holdover Mode, holdover stability is determined by the stability of the 20 MHz Master Clock Oscillator. Selection of the oscillator requires close examination of the crystal oscillator temperature sensitivity and frequency drift caused by aging.

Auto Holdover State

The Auto Holdover state is a transitional state that the ZL30410 enters automatically when the active reference fails unexpectedly. When the ZL30410 detects loss of reference it sets the HOLDOVER status pin and waits in Auto Holdover state until the failed reference recovers. Recovery from Auto Holdover for 8 kHz, 1.544 MHz, 2.048 MHz and 19.44 MHz reference clocks is fully automatic, however recovery for an 8 kHz reference clock requires additional transitioning through the Holdover state to guarantee compliance with network synchronization standards (for details see section 4.1.3 on page 18 and section 4.1.2 on page 17). The HOLDOVER status may alert the external control processor (or CPLD logic) about the failure and in response the control processor may switch to the secondary reference clock. The Auto Holdover and Holdover States are internally combined together and they are output as a HOLDOVER status on pin 55.

2.4.3 State Transitions

In a typical application, the ZL30410 will most of the time operate in Normal mode (MS2, MS1 == 00) generating synchronous clocks. Its two Acquisition PLLs will continuously monitor the input references for signs of degraded quality and output status information for further processing. The status information from the Acquisition PLLs and the CORE PLL combined with status information from line interfaces and framers (as listed below) forms the basis for creating reliable network synchronization.

- Acquisition PLLs (PRIOR, SECOR)
- Core PLL (LOCK, HOLDOVER)
- Line interfaces (e.g. LOS - Loss of Signal, AIS - Alarm Indication Signal)
- Framers (e.g. LOF - Loss of frame or Synchronization Status Messages carried over SONET S1 byte or ESF-DS1 Facility Data Link).

The ZL30410 State Machine is designed to perform some transitions automatically, leaving other less time dependent tasks to the external controlling processor (or CPLD logic). The state machine includes two stimulus signals which are critical to automatic operation: "OK --> FAIL" and "FAIL --> OK" that represent loss (and recovery) of reference signal or its drift by more than ± 30000 ppm. Both of them force the Core PLL to transition into and out of the Auto Holdover state. The ZL30410 State Machine is driven by controlling the mode select pins MS2, MS1 and RefSel. In order to avoid synchronization problems, the State Machine has built-in basic protection that does not allow switching the Core PLL into a state where it cannot operate correctly e.g. it is not possible to force the Core PLL into Normal mode when all references are lost.

2.5 JTAG Interface

The ZL30410 JTAG (Joint Test Action Group) interface conforms to the Boundary-Scan standard IEEE1149.1-1990, which specifies a design-for-testability technique called Boundary-Scan Test (BST). The BST architecture is made up of four basic elements, Test Access Port (TAP), TAP Controller, Instruction Register (IR) and Test Data Registers (TDR) and all these elements are implemented on the ZL30410.

Zarlink Semiconductor provides a Boundary Scan Description Language (BSDL) file that contains all the information required for a JTAG test system to access the ZL30410's boundary scan circuitry. The file is available for download from the Zarlink Semiconductor web site: www.zarlink.com.

3.0 Control Interface

The ZL30410 has a built-in simple control interface that makes it suitable for application that can provide only a limited amount of supervision. This allows for building multi-service line cards without extensive programming. The complete set of control and status pins is shown in Figure 6 - Control Interface on page 14.

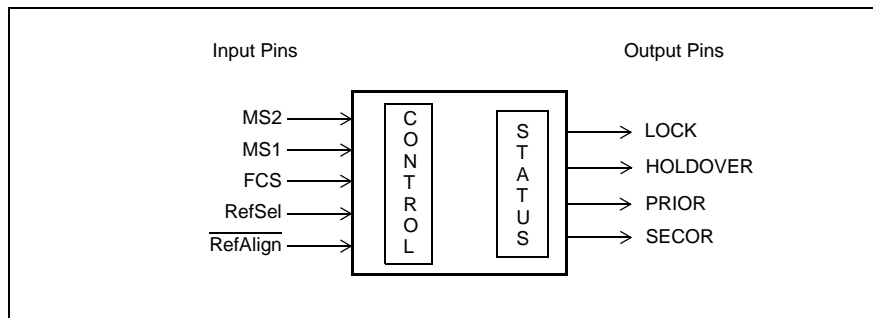

Figure 6 - Control Interface

3.1 Control Pins

The ZL30410 has five dedicated control pins for selecting modes of operation and activating different functions. These pins are listed below:

MS2 and MS1 pins: Mode Select: The MS2 (pin 19) and MS1 (pin 18) inputs select the PLL mode of operation. See Table 1 for details. The logic level at these inputs is sampled by the rising edge of the F8o frame pulse.

MS2	MS1	Mode of Operation
0	0	Normal mode
0	1	Holdover mode
1	0	Free-run
1	1	Reserved

Table 1 - Operating Modes and States

FCS pin: Filter Characteristic Select. The FCS (pin 9) input is used to select the filtering characteristics of the Core PLL. See Table 2 on page 15 for details.

FCS	Filtering Characteristic	Phase Slope Limit
0	Filter corner frequency set to 12Hz. This selection meets loop filter characteristics for line card applications	N/A
1	Filter corner frequency set to 6Hz. This selection meets requirements of G.813 Option 1	41 ns in 1.326 ms

Table 2 - Filter Characteristic Selection

RefSel: Reference Source Select. The RefSel (pin 47) input selects the PRI (primary) or SEC (secondary) input as the reference clock for the Core PLL. The logic level at this input is sampled by the rising edge of F8o.

RefSel	Input Reference
0	Core PLL connected to the Primary Acquisition PLL
1	Core PLL connected to the Secondary Acquisition PLL

Table 3 - Reference Source Select

RefAlign: Reference Alignment. The RefAlign (pin 48) input controls phase realignment between the input reference and the generated output clocks. See Section 2.2.4 on page 9 for details.

3.2 Status Pins

The ZL30410 has four dedicated status pins for indicating modes of operation and quality of the Primary and Secondary reference clocks. These pins are listed below:

LOCK. This output goes high after the ZL30410 has completed its locking sequence (see section 2.2.3 for details).

HOLDOVER - This output goes high when the Core PLL enters Holdover mode. The Core PLL will switch to Holdover mode if the respective Acquisition PLL enters Holdover mode or if the mode select pins are set to Holdover (MS2, MS1 = 01).

PRIOR - (Primary Reference Out of Range). The PRIOR status is based on two detectors that monitor reference quality with different precision and response times. Outputs of both detectors are combined together (OR function) to drive PRIOR status pin.

This output goes high when one of the detectors is triggered by the failing Primary Reference clock:

- Slow Response Detector (High Precision): This detector detects if the primary reference is off its nominal frequency by more than ± 12 ppm. The frequency offset monitor updates internally every 10 sec and will change state after two matching measurements (PASS/PASS or FAIL/FAIL). This is in full compliance with the GR-1244-CORE requirement of 10 to 30 sec Reference Validation Time. This output returns to zero when the reference frequency is requalified within ± 9.2 ppm of the nominal frequency (monitor circuit has built-in hysteresis). In an extreme case, when over time the Master Clock oscillator drifts ± 4.6 ppm the switching thresholds will change as well, as is shown in Figure 7.
- Fast Response Detector (Low Precision): This detector detects a large frequency offset (greater than 3%) or large change in a single cycle period (greater than 30%). In both cases detector will almost instantaneously (in less than 250 μ s) disqualify the reference and reset the 10 sec internal timer.

SECOR - (Secondary Reference Out of Range). Functionally, this pin is equivalent to the PRIOR pin for Primary Acquisition PLL.

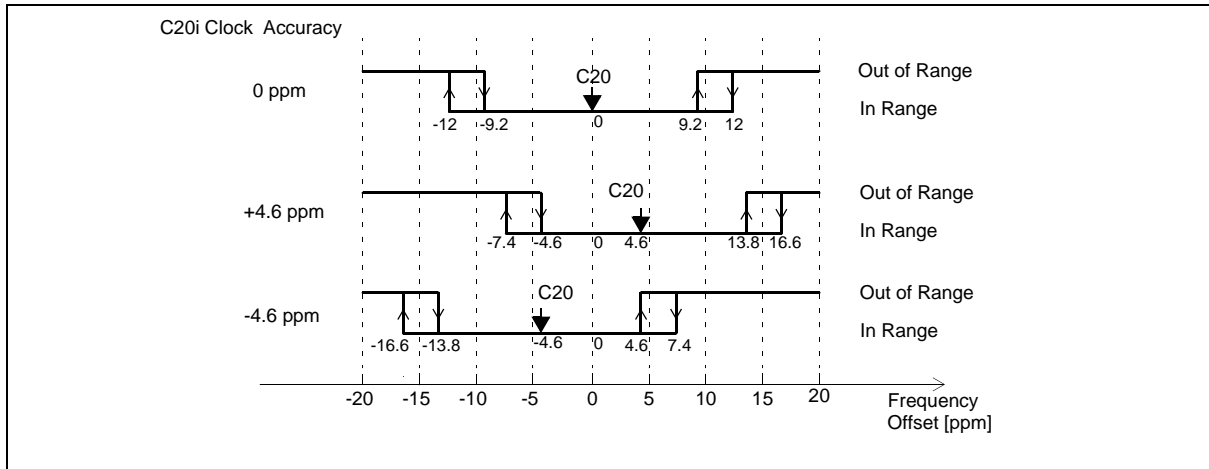

Figure 7 - Primary and Secondary Reference Out of Range Thresholds

4.0 Applications

This section provides application examples frequently found in a typical Line Card being part of Network Element operating in a synchronous network.

4.1 ZL30410 Switching Between Clock Modes

The ZL30410 is designed to transition from one mode to the other driven by the internal State Machine or by external control. The following examples present a couple of typical scenarios of how the ZL30410 can be employed in network interface line cards.

4.1.1 System Start-up Sequence: FREE-RUN --> HOLDOVER --> NORMAL

The FREE-RUN to HOLDOVER to NORMAL transition represents a sequence of steps that will most likely occur during a new system installation or scheduled maintenance. The process starts from the RESET state and then transitions to Free-run mode where the system (card) is being initialized. At the end of this process the ZL30410 should be switched into Normal mode (with MS2, MS1 set to 00) instead of Holdover mode. If the reference clock is available, the ZL30410 will transition briefly into Holdover to acquire synchronization and switch automatically to Normal mode. If the reference clock is not available at this time, as it may happen during new system installation, then the ZL30410 will stay in Holdover indefinitely. While in Holdover mode, the Core PLL will continue generating clocks with the same accuracy as in the Free-run mode, waiting for a good reference clock. When the line card become connected to the timing card the Acquisition PLL will quickly synchronize and clear its own Holdover status. This will enable the Core PLL to start the synchronization process. After acquiring lock, the ZL30410 will automatically switch from Holdover into Normal mode without system intervention. This transition to the Normal mode will be flagged by the LOCK status pin.

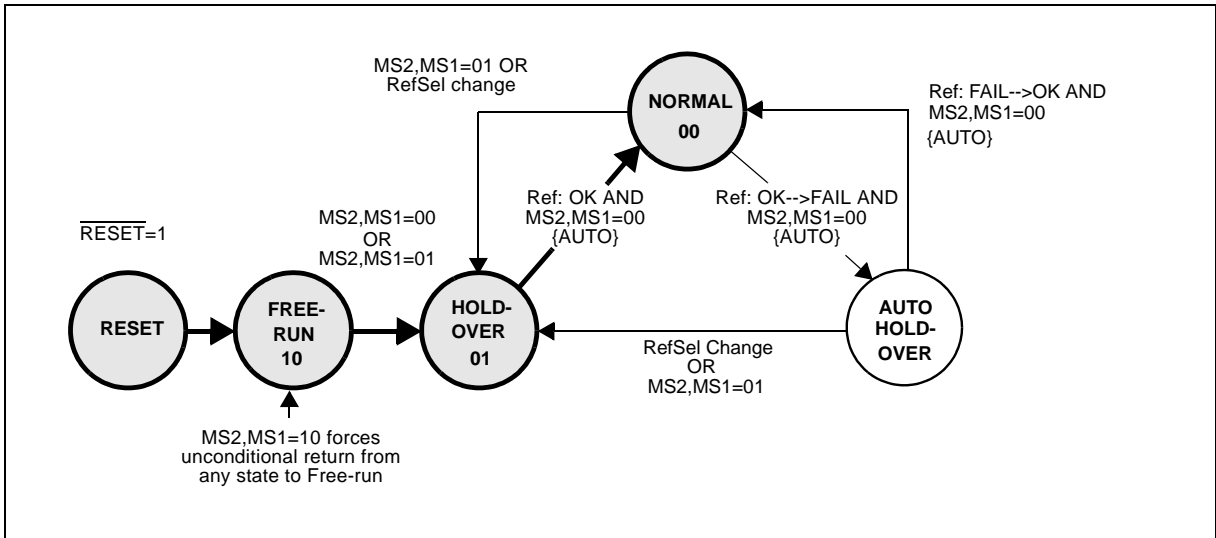

Figure 8 - Transition from Free-run to Normal mode

4.1.2 Single Reference Operation: NORMAL --> AUTO HOLDOVER --> NORMAL

The NORMAL to AUTO-HOLDOVER to NORMAL transition will usually happen when the Line Card loses its single reference clock unexpectedly. The sequence starts with the reference clock transitioning from OK --> FAIL at a time when ZL30410 operates in Normal mode (as is shown in Figure 10). This failure is detected by the active Acquisition PLL based on the following FAIL criteria:

- Frequency offset on 8 kHz, 1.544 MHz, 2.048 MHz and 19.44 MHz reference clocks exceeds ± 30000 ppm ($\pm 3\%$).
- Single phase hit on 1.544 MHz, 2.048 MHz and 19.44 MHz exceeds half of the cycle of the reference clock.

After detecting any of these anomalies on a reference clock the Acquisition PLL will switch itself into Holdover mode forcing the Core PLL to automatically switch into the Auto Holdover state. This condition is flagged by LOCK = 0 and HOLDOVER = 1.

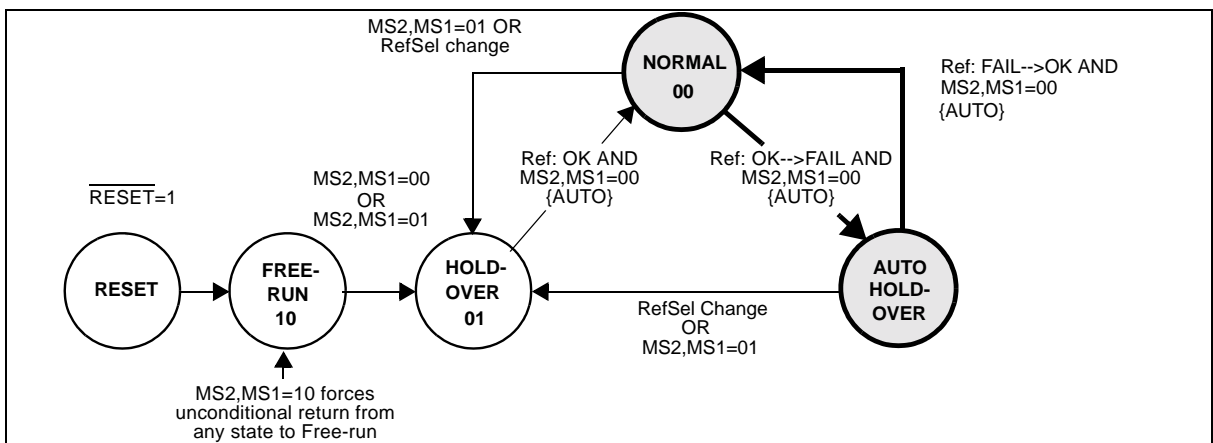

Figure 9 - Automatic entry into Auto Holdover State and recovery into Normal mode

The Core PLL will automatically return to the Normal state after the reference signal recovers from failure. This transition is shown on the state diagram as a FAIL --> OK change. This change becomes effective when the reference is restored and there have been no phase hits detected for at least 64 clock cycles for the 1.544/2.048 MHz reference, 512 clock cycles for the 19.44 MHz reference and 1 clock cycle for the 8 kHz reference.

This transition from Auto Holdover to Normal mode is performed as “hit-less” recovery for 1.544 MHz, 2.048 MHz and 19.44 MHz references. For the 8 kHz input reference, the recovery from Auto Holdover state must transition through the Holdover state to guarantee “hit-less” recovery (for details see section 4.1.3 on page 18).

4.1.3 Single 8 kHz Reference Operation: NORMAL --> AUTO HOLDOVER--> HOLDOVER --> NORMAL

The sequence starts from the Normal state and transitions to Auto Holdover state due to an unforeseen loss of the 8 kHz reference. The failure conditions triggering this transition are described in section 4.1.2. When in the Auto Holdover state, the ZL30410 can return to Normal mode automatically but this transition may exceed Output Phase Continuity limits specified in the Performance Characteristic Table listed in section “Performance Characteristics” on page 29. This probable time interval error is avoidable by forcing the PLL into Holdover state immediately after detection of the 8 kHz reference failure. While in Holdover state the ZL30410 will continue monitoring quality of the input reference (if a proper ±4.6ppm Master Clock oscillator is employed) and after detecting the presence of a valid reference it can be switched into Normal state. When the Master Clock Oscillator accuracy exceeds ±4.6ppm range (leading to inaccurate internal out-of-range detection) then an external method for detecting the presence of the clock should be employed to switch the ZL30410 into Normal state (0.1 sec after detecting the presence of a valid 8 kHz reference).

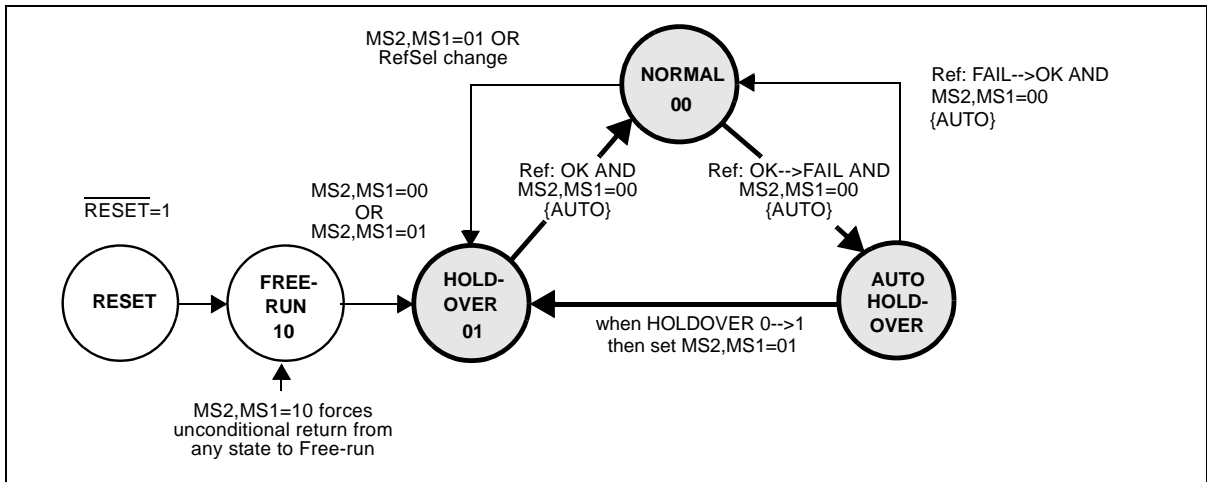

Figure 10 - Recovery procedure from a single 8 kHz reference failure by transitioning through the Holdover state

4.1.4 Dual Reference Operation: NORMAL --> AUTO HOLDOVER--> HOLDOVER --> NORMAL

The NORMAL to AUTO-HOLDOVER to HOLDOVER to NORMAL sequence represents the most likely operation of the ZL30410.

The sequence starts from the Normal state and transitions to Auto Holdover state due to an unforeseen loss of reference. The failure conditions triggering this transition were described in section 4.1.2. When in the Auto Holdover state, the ZL30410 can return to Normal mode automatically if the lost reference is restored. This transition from Auto Holdover to Normal mode is performed as “hit-less” recovery for 1.544 MHz, 2.048 MHz and 19.44 MHz references. For the 8 kHz input reference, the recovery from Auto Holdover state must transition through the Holdover state to guarantee “hit-less” recovery (for details see section 4.1.3 on page 18). If the reference clock failure persists for a period of time that exceeds the system design limit, the system control processor may initiate a reference switch. If the secondary reference is available the ZL30410 will briefly switch into Holdover mode and then transition to Normal mode.

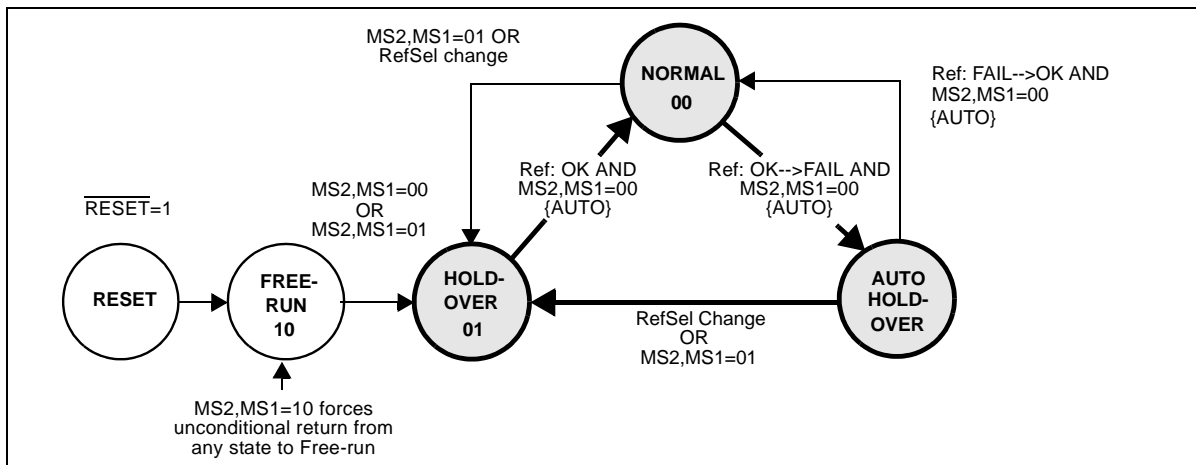

Figure 11 - Entry into Auto Holdover state and recovery into Normal mode by switching references

The new reference clock will most likely have a different phase but it may also have a different fractional frequency offset. In order to lock to a new reference with a different frequency, the Core PLL may be stepped gradually towards the new frequency.

4.1.5 Reference Switching (RefSel): NORMAL --> HOLDOVER --> NORMAL

The NORMAL to HOLDOVER to NORMAL mode switching is usually performed when:

- A reference clock is available but its frequency drifts beyond some specified limit. In a Network Element with stratum 3 internal clocks, the reference failure is declared when its frequency drifts more than ± 12 ppm beyond its nominal frequency. The ZL30410 indicates this condition by setting PRIOR or SECOR status pins to logic high.
- During routine maintenance of equipment when orderly switching of reference clocks is possible. This may happen when synchronization references must be rearranged or when a faulty timing card must be replaced.

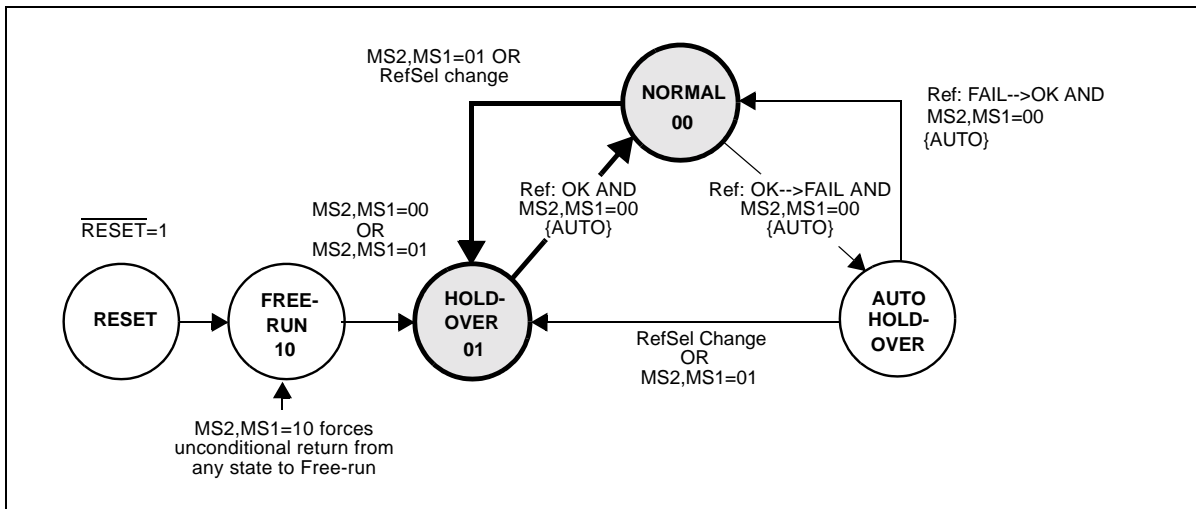

Figure 12 - Manual Reference Switching

Two types of transitions are possible:

- Semi-automatic transition, which involves changing RefSel input to select a secondary reference clock without changing the mode select inputs MS2,MS1=00 (Normal mode). This forces the ZL30410 to momentarily transition through the Holdover state and automatically return to Normal mode after synchronizing to a secondary reference clock.
- Manual transition, which involves switching into Holdover mode (MS2,MS1=01), changing references with RefSel, and manual return to the Normal mode (MS2, MS1=00).

In both cases, the change of references provides "hit-less" switching.

4.2 Power supply filtering

Figure 13 presents a complete filtering arrangement that is recommended for applications requiring maximum jitter performance.

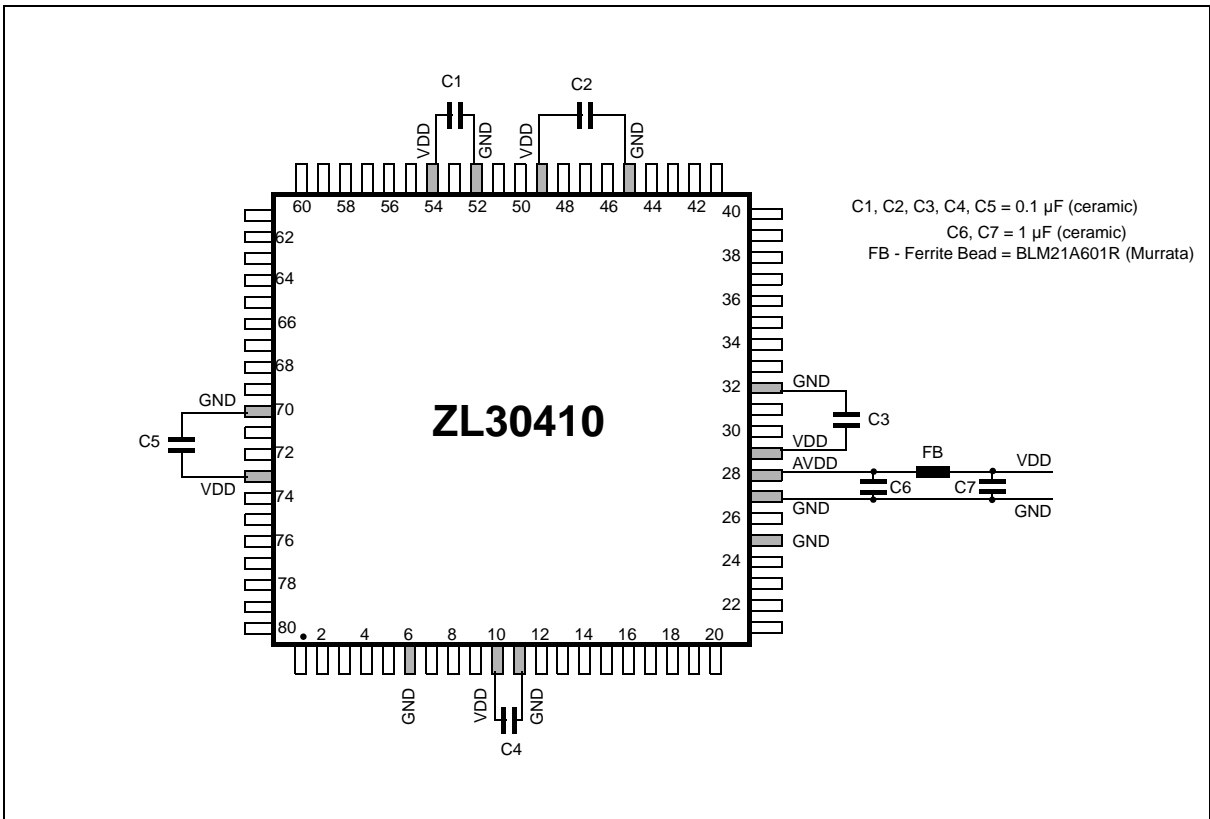

Figure 13 - Power supply filtering

5.0 Characteristics

5.1 AC and DC Electrical Characteristics

Absolute Maximum Ratings*

	Parameter	Symbol	Min	Max	Units
1	Supply voltage	V_{DDR}	-0.3	7.0	V
2	Voltage on any pin	V_{PIN}	-0.3	VDD+0.3	V
3	Current on any pin	I_{PIN}		30	mA
4	Storage temperature	T_{ST}	-55	125	°C
5	Package power dissipation (80 pin LQFP)	P_{PD}		1000	mW
6	ESD rating	V_{ESD}		1500	V

* Voltages are with respect to ground (GND) unless otherwise stated

* Exceeding these values may cause permanent damage. Functional operation under these conditions is not implied.

Recommended Operating Conditions*

	Characteristics	Symbol	Min	Typ	Max	Units
1	Supply voltage	V_{DD}	3.0	3.3	3.6	V
2	Operating temperature	T_A	-40	25	+85	°C

* Voltages are with respect to ground (GND) unless otherwise stated

DC Electrical Characteristics*

	Characteristics	Symbol	Min	Max	Units	Notes
1	Supply current with C20i = 20MHz	I_{DD}		155	mA	Outputs unloaded
2	Supply current with C20i = 0V	I_{DDS}		3.5	mA	Outputs unloaded
3	CMOS high-level input voltage	V_{CIH}	$0.7V_{DD}$		V	
4	CMOS low-level input voltage	V_{CIL}		$0.3V_{DD}$	V	
5	Input leakage current	I_{IL}		15	μA	$V_I = V_{DD}$ or GND
6	High-level output voltage	V_{OH}	2.4		V	$I_{OH} = 10mA$
7	Low-level output voltage	V_{OL}		0.4	V	$I_{OL} = 10mA$
8	LVDS: Differential output voltage	V_{OD}	250	450	mV	$Z_T = 100\Omega$
9	LVDS: Change in VOD between complementary output states	dV_{OD}		50	mV	$Z_T = 100\Omega$
10	LVDS: Offset voltage	V_{OS}	1.125	1.375	V	Note 1
11	LVDS: Change in VOS between complementary output states	dV_{OS}		50	mV	
12	LVDS: Output short circuit current	I_{OS}		24	mA	Pin short to GND
13	LVDS: Output rise and fall times	T_{RF}	260	900	ps	Note 2

* Voltages are with respect to ground (GND) unless otherwise stated

Note 1: V_{OS} is defined as $(V_{OH} + V_{OL}) / 2$

Note 2: Rise and fall times are measured at 20% and 80% levels.

AC Electrical Characteristics - Timing Parameter Measurement - CMOS Voltage Levels*

	Characteristics	Symbol	Level	Units
1	Threshold voltage	V_T	$0.5V_{DD}$	V
2	Rise and fall threshold voltage High	V_{HM}	$0.7V_{DD}$	V
3	Rise and fall threshold voltage Low	V_{LM}	$0.3V_{DD}$	V

- * Voltages are with respect to ground (GND) unless otherwise stated
- * Supply voltage and operating temperature are as per Recommended Operating Conditions
- * Timing for input and output signals is based on the worst case conditions (over T_A and V_{DD})

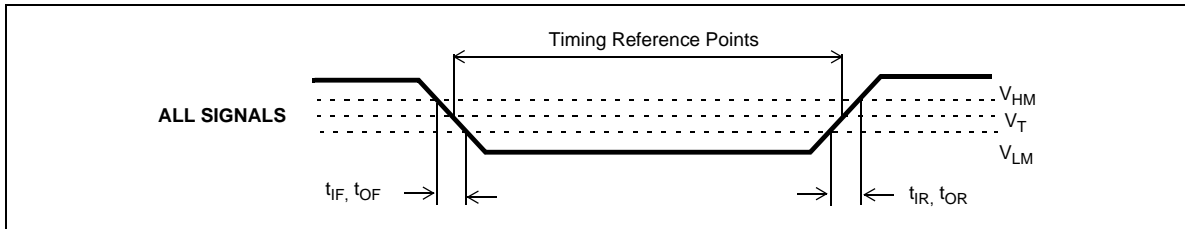

Figure 14 - Timing Parameters Measurement Voltage Levels

AC Electrical Characteristics - ST-BUS and GCI Output Timing*

	Characteristics	Symbol	Min	Max	Units	Notes
1	$\overline{F16o}$ pulse width low (nom 61 ns)	t_{F16L}	56	62	ns	
2	F8o to $\overline{F16o}$ delay	t_{F16D}	27	33	ns	
3	$\overline{C16o}$ pulse width low	t_{C16L}	26	32	ns	
4	F8o to $\overline{C16o}$ delay	t_{C16D}	-3	3	ns	
5	F8o pulse width high (nom 122 ns)	t_{F8H}	119	125	ns	
6	C8o pulse width low	t_{C8L}	56	62	ns	
7	F8o to C8o delay	t_{C8D}	-3	3	ns	
8	$\overline{F0o}$ pulse width low (nom 244 ns)	t_{F0L}	241	247	ns	
9	F8o to $\overline{F0o}$ delay	t_{F0D}	119	125	ns	
10	$\overline{C4o}$ pulse width low	t_{C4L}	119	125	ns	
11	F8o to $\overline{C4o}$ delay	t_{C4D}	-3	3	ns	
12	C2o pulse width low	t_{C2L}	240	246	ns	
13	F8o to C2o delay	t_{C2D}	-3	3	ns	

* Supply voltage and operating temperature are as per Recommended Operating Conditions

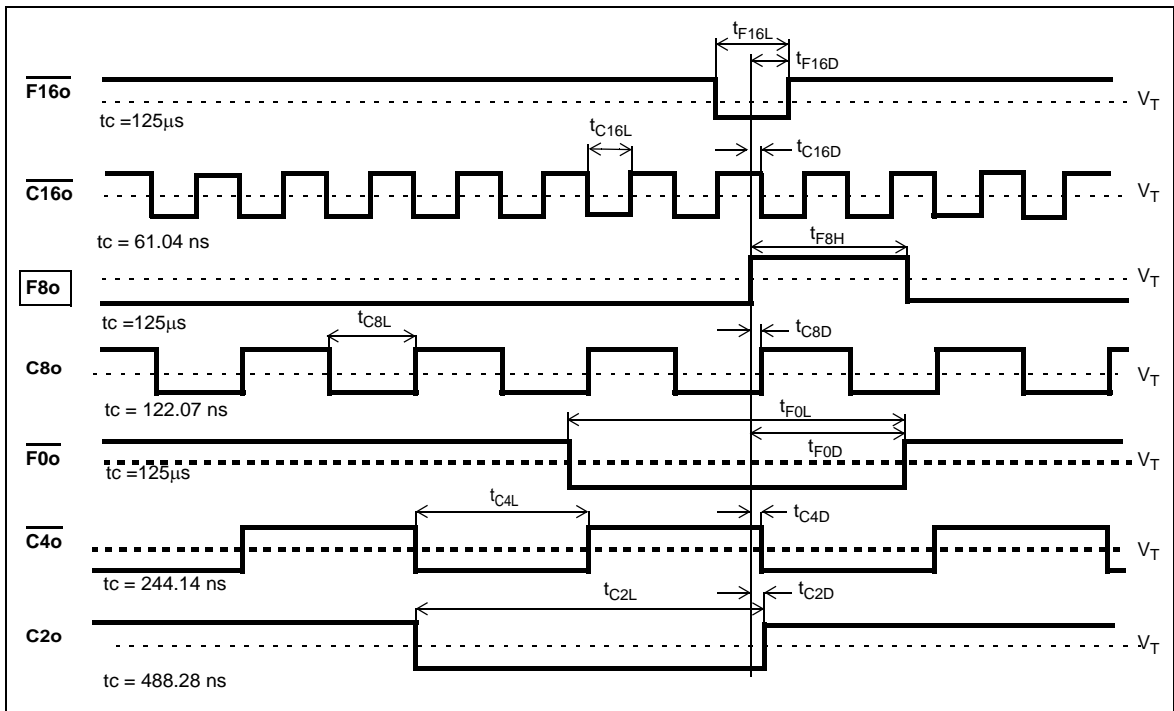

Figure 15 - ST-BUS and GCI Output Timing

AC Electrical Characteristics - DS1 and DS2 Clock Timing*

	Characteristics	Symbol	Min	Max	Units	Notes
1	C6o pulse width low	t_{C6L}	75	83	ns	
2	F8o to C6o delay	t_{C6D}	-4	11	ns	
3	C1.5o pulse width low	$t_{C1.5L}$	320	328	ns	
4	F8o to C1.5o delay	$t_{C1.5D}$	-4	11	ns	

* Supply voltage and operating temperature are as per Recommended Operating Conditions

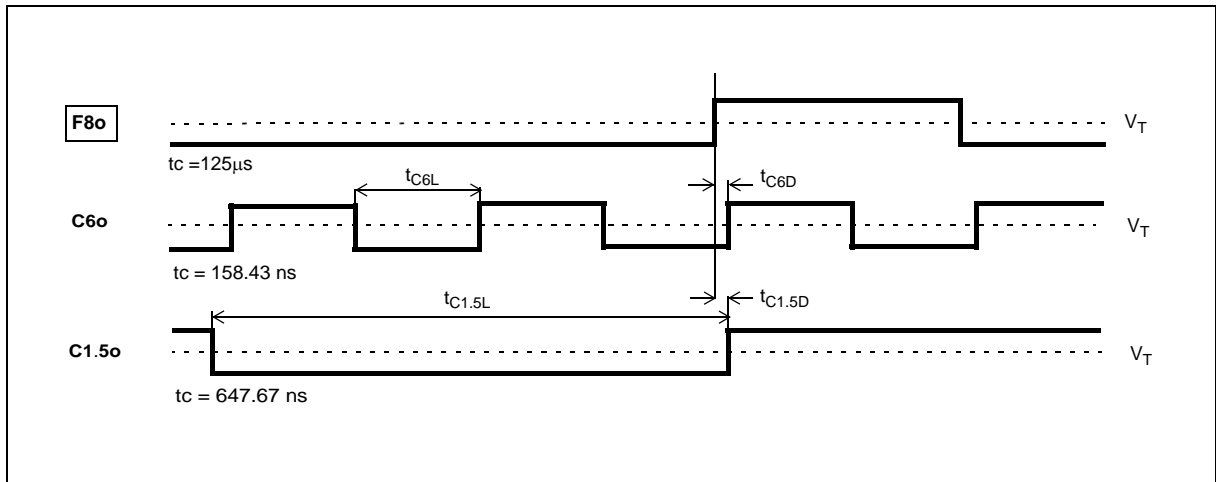

Figure 16 - DS1 and DS2 Clock Timing

AC Electrical Characteristics - C155o and C19o Clock Timing

	Characteristics	Symbol	Min	Max	Units	Notes
1	C155o pulse width low	t_{C155L}	2.6	3.8	ns	
2	C155o to C19o rising edge delay	t_{C19DLH}	-1	7	ns	
3	C155o to C19o falling edge delay	t_{C19DHL}	-2	6	ns	
4	C19 pulse width high	t_{C19H}	23	29		

* Supply voltage and operating temperature are as per Recommended Operating Conditions

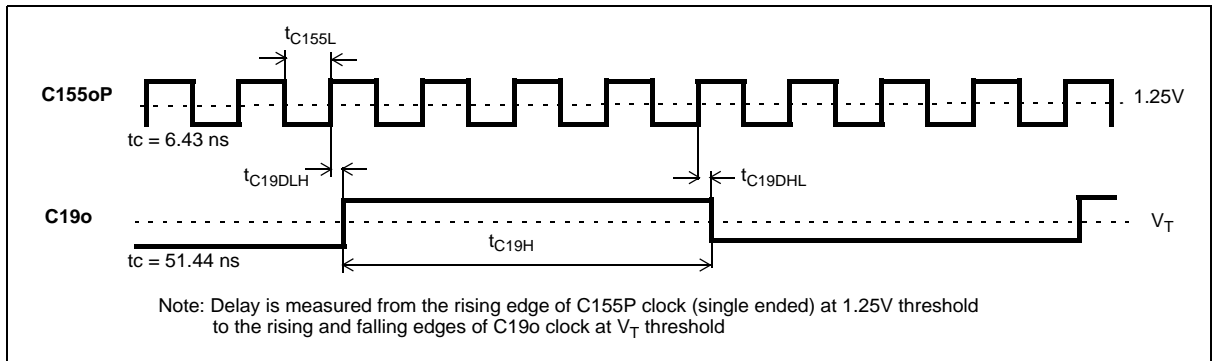

Figure 17 - C155o and C19o Timing

AC Electrical Characteristics - Input to Output Phase Offset (after phase realignment)*

	Characteristics	Symbol	Min	Max	Units	Notes
1	8 kHz ref pulse width high or low	t_{R8W}	100		ns	
2	8 kHz ref input to F8o delay	t_{R8D}	13	31	ns	
3	1.544 MHz ref: pulse width high or low	$t_{R1.5W}$	100		ns	
4	1.544 MHz ref input to F8o delay	$t_{R1.5D}$	335	350	ns	
5	2.048 MHz ref: pulse width high or low	t_{R2W}	100		ns	
6	2.048 MHz ref input to F8o delay	t_{R2D}	255	272	ns	
7	19.44 MHz ref: pulse width high or low	t_{R19W}	20		ns	
8	19.44 MHz ref input to F8o delay	t_{R19D}	8	21	ns	
9	F8o to C19o delay	t_{C19D}	-5	7	ns	
10	Reference input rise and fall time	t_{IR}, t_{IF}		10	ns	

* Supply voltage and operating temperature are as per Recommended Operating Conditions

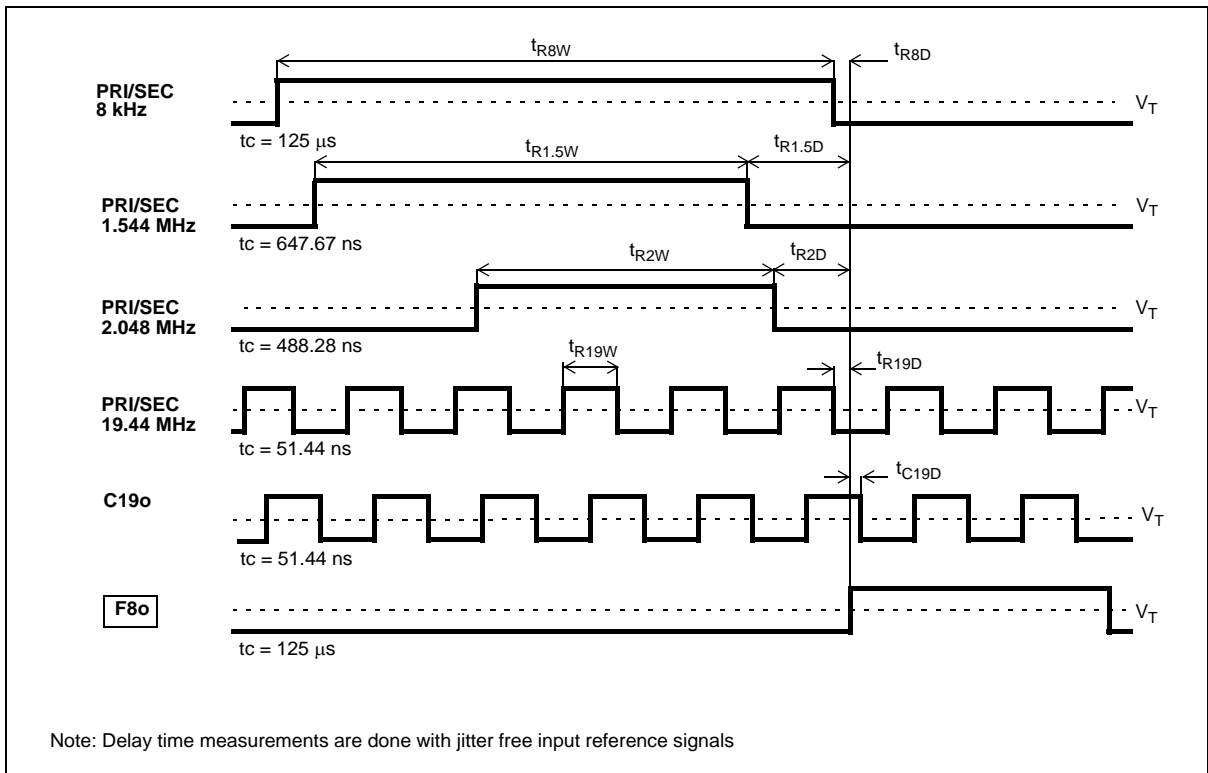

Figure 18 - Input Reference to Output Clock Phase Alignment

AC Electrical Characteristics - Input Control Signals*

	Characteristics	Symbol	Min	Max	Units	Notes
1	Input controls Setup time	t_s	100		ns	
2	Input controls Hold time	t_H	100		ns	

* Supply voltage and operating temperature are as per Recommended Operating Conditions

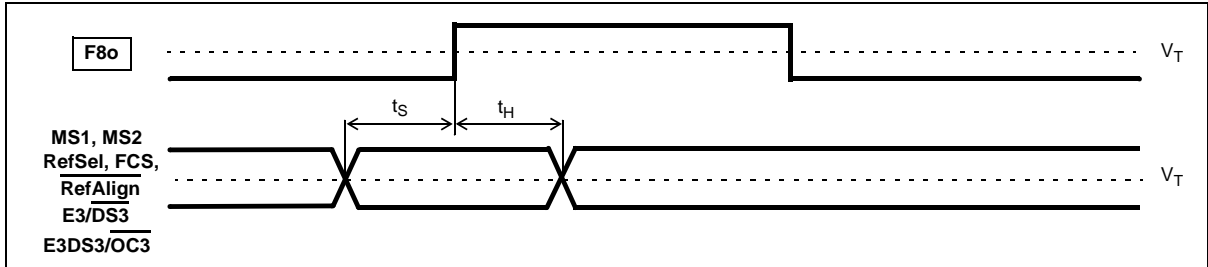

Figure 19 - Input Control Signal Setup and Hold Time

AC Electrical Characteristics - E3 and DS3 Output Timing*

	Characteristics	Symbol	Min	Max	Units	Notes
1	C44o clock pulse width high	t_{C44H}	11	13	ns	
2	C11o clock pulse width high	t_{C11H}	5	26	ns	
3	C34o clock pulse width high	t_{C34H}	13	16	ns	
4	C8.5o clock pulse width high	$t_{C8.5H}$	9	24	ns	

* Supply voltage and operating temperature are as per Recommended Operating Conditions

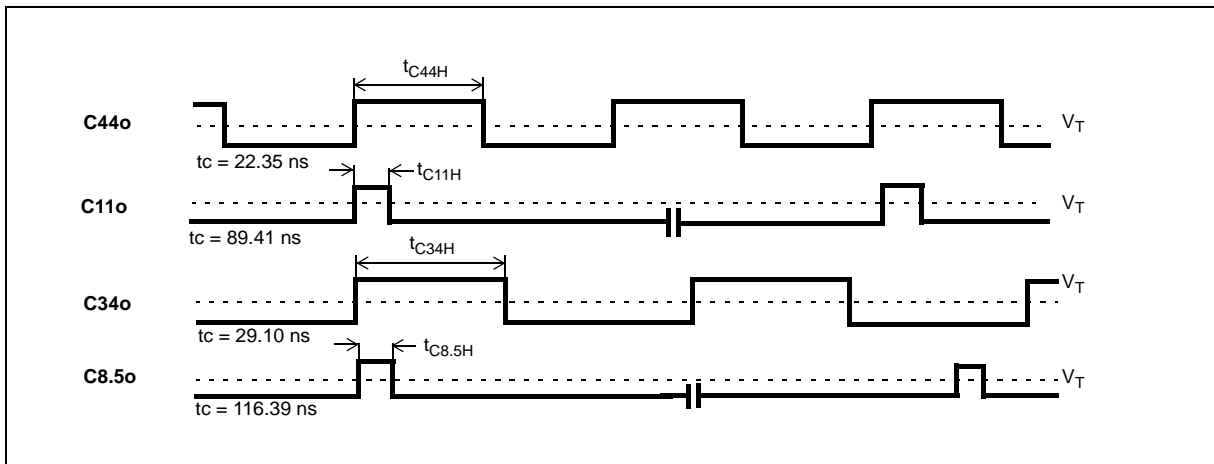

Figure 20 - E3 and DS3 Output Timing

5.2 Performance Characteristics

Performance Characteristics*

	Characteristics	MIN	TYP	MAX	Units	Notes
1	Holdover accuracy (6Hz filter)		70×10^{-12}	160×10^{-12}	Hz/Hz	
2	Holdover accuracy (12Hz filter)		140×10^{-12}	320×10^{-12}	Hz/Hz	
3	Holdover stability		NA		Hz/Hz	Holdover Stability is determined by stability of the 20 MHz Master Clock oscillator
4	Capture range	-104		+104	ppm	The 20 MHz Master Clock oscillator set at 0ppm
5	Reference Out of Range Threshold	-12		+12	ppm	The 20 MHz Master Clock oscillator set at 0ppm
Lock Time						
6	6 Hz or 12 Hz Filter			6	s	± 4.6 ppm frequency offset
7	6 Hz or 12 Hz Filter			6	s	± 20 ppm frequency offset
Output Phase Continuity (MTIE)						
8	Reference switching: PRI \Rightarrow SEC, SEC \Rightarrow PRI			50	ns	PRI = SEC = 8 kHz
				5	ns	PRI or SEC = 1.544 MHz, 2.048 MHz, 19.44 MHz
9	Switching from Normal mode to Holdover mode			0	ns	
10	Switching from Holdover mode to Normal mode			50	ns	PRI = SEC = 8 kHz
				2	ns	PRI or SEC = 1.544 MHz, 2.048 MHz, 19.44 MHz
Output Phase Slope						
11	6 Hz Loop Filter	41			$\frac{\text{ns}}{1.326\text{ms}}$	

* Supply voltage and operating temperature are as per Recommended Operating Conditions

Performance Characteristics : Measured Output Jitter - GR-253-CORE and T1.105.03 conformance

Telcordia GR-253-CORE and ANSI T1.105.03 Jitter Generation Requirements					ZL30410 Jitter Generation Performance		
	Interface	Jitter Measurement Filter	Limit in UI	Equivalent limit in time domain	TYP	Units	Notes
					C155 Clock Output		
1	OC-3 155.52 Mbit/s	65kHz to 1.3MHz	0.15 UIpp	0.964	0.325	nSp.p	
2		12kHz to 1.3MHz (Category II)	0.1 UIpp	0.643	0.408	nSp.p	
			0.01 UI _{RMS}	0.064	0.038	n _{RMS}	
3		500Hz to 1.3MHz	1.5 UIpp	9.645	0.448	nSp.p	
					C19 Clock Output		
4	OC-3 155.52 Mbit/s	65kHz to 1.3MHz	0.15 UIpp	0.964	0.390	nSp.p	
5		12kHz to 1.3MHz (Category II)	0.1 UIpp	0.643	0.458	nSp.p	
			0.01 UI _{RMS}	0.064	0.040	n _{RMS}	
6		500Hz to 1.3MHz	1.5 UIpp	9.645	0.512	nSp.p	

* Supply voltage and operating temperature are as per Recommended Operating Conditions

Performance Characteristics : Measured Output Jitter - T1.403 conformance

ANSI T1.403 Jitter Generation Requirements					ZL30410 Jitter Generation Performance		
	Interface	Jitter Measurement Filter	Limit in UI	Equivalent limit in time domain	TYP	Units	Notes
					C1.5 Clock Output		
1	DS1 1.544 Mbit/s	8 kHz to 40 kHz	0.07 UIpp	45.3	0.63	nSp.p	
2		10 Hz to 40 kHz	0.5 UIpp	324	0.93	nSp.p	

* Supply voltage and operating temperature are as per Recommended Operating Conditions

Performance Characteristics : Measured Output Jitter - G.747 conformance

ITU-T G.747 Jitter Generation Requirements					ZL30410 Jitter Generation Performance		
	Interface	Jitter Measurement Filter	Limit in UI	Equivalent limit in time domain	TYP	Units	Notes
					C6 Clock Output		
1	DS2 6312 kbit/s	10 Hz to 60kHz	0.05 UIpp	7.92	0.53	ns _{p-p}	

* Supply voltage and operating temperature are as per Recommended Operating Conditions

Performance Characteristics : Measured Output Jitter - T1.404 conformance

ANSI T1.403 Jitter Generation Requirements					ZL30410 Jitter Generation Performance		
	Interface Type I	Jitter Measurement Filter	Limit in UI	Equivalent limit in time domain	TYP	Units	Notes
					C44 Clock Output		
1	DS3 44.736 Mbit/s	30 kHz to 400 kHz	0.05 UIpp	1.12	0.30	ns _{p-p}	
2		10 Hz to 400 kHz	0.5 UIpp	11.2	0.47	ns _{p-p}	

* Supply voltage and operating temperature are as per Recommended Operating Conditions

Performance Characteristics : Measured Output Jitter - G.732, G.735 to G.739 conformance

ITU-T G.732, G.735, G.736, G.737, G.738, G.739 Jitter Generation Requirements					ZL30410 Jitter Generation Performance		
	Interface	Jitter Measurement Filter	Limit in UI	Equivalent limit in time domain	TYP	Units	Notes
					C16, C8, C4 and C2 Clock Outputs		
1	E1 2048 kbit/s	20 Hz to 100 kHz	0.05 UIpp	24.4	0.56	nSp-p	

* Supply voltage and operating temperature are as per Recommended Operating Conditions

Performance Characteristics : Measured Output Jitter - G.751 conformance

ITU-T G.751 Jitter Generation Requirements					ZL30410 Jitter Generation Performance		
	Interface	Jitter Measurement Filter	Limit in UI	Equivalent limit in time domain	TYP	Units	Notes
					C34 Clock Output		
1	E3 34368 kbit/s	100 Hz to 800 kHz	0.05 UIpp	1.45	0.64	nSp-p	

* Supply voltage and operating temperature are as per Recommended Operating Conditions

Performance Characteristics : Measured Output Jitter - G.812 conformance

ITU-T G.812 Jitter Generation Requirements					ZL30410 Jitter Generation Performance		
	Interface	Jitter Measurement Filter	Limit in UI	Equivalent limit in time domain	TYP	Units	Notes
					C155 Clock Output		
1	STM-1 optical 155.52 Mbit/s	65kHz to 1.3MHz	0.1 Ulpp	0.643	0.325	nSp,p	
2		500Hz to 1.3MHz	0.5 Ulpp	3.215	0.448	nSp,p	
					C155 Clock Output		
3	STM-1 electrical 155.52 Mbit/s	65kHz to 1.3MHz	0.075 Ulpp	0.482	0.325	nSp,p	
4		500Hz to 1.3MHz	0.5 Ulpp	3.215	0.448	nSp,p	
					C19 Clock Output		
5	STM-1 optical 155.52 Mbit/s	65kHz to 1.3MHz	0.1 Ulpp	0.643	0.390	nSp,p	
6		500Hz to 1.3MHz	0.5 Ulpp	3.215	0.512	nSp,p	
					C19 Clock Output		
7	STM-1 electrical 155.52 Mbit/s	65kHz to 1.3MHz	0.075 Ulpp	0.482	0.390	nSp,p	
8		500Hz to 1.3MHz	0.5 Ulpp	3.215	0.512	nSp,p	
					C16, C8, C4 and C2 Clock Outputs		
9	E1 2048 kbit/s	20 Hz to 100 kHz	0.05 Ulpp	24.4	0.56	nSp,p	
					C1.5 Clock Output		
10	DS1 1.544 Mbit/s	10 Hz to 40 kHz	0.05 Ulpp	32.4	0.93	nSp,p	

* Supply voltage and operating temperature are as per Recommended Operating Conditions

Performance Characteristics : Measured Output Jitter - G.813 conformance (Option 1)

ITU-T G.813 Jitter Generation Requirements					ZL30410 Jitter Generation Performance		
	Interface	Jitter Measurement Filter	Limit in UI	Equivalent limit in time domain	TYP	Units	Notes
Option 1					C155 Clock Output		
1	STM-1 155.52 Mbit/s	65kHz to 1.3MHz	0.1 Ulpp	0.643	0.325	nSp.p	
2		500Hz to 1.3MHz	0.5 Ulpp	3.215	0.448	nSp.p	
					C19 Clock Output		
3	STM-1 155.52 Mbit/s	65kHz to 1.3MHz	0.1 Ulpp	0.643	0.390	nSp.p	
4		500Hz to 1.3MHz	0.5 Ulpp	3.215	0.512	nSp.p	
					$\overline{C16}$, C8, $\overline{C4}$ and C2 Clock Outputs		
5	E1 2048 kbit/s	20 Hz to 100 kHz	0.05 Ulpp	24.4	0.56	nSp.p	

* Supply voltage and operating temperature are as per Recommended Operating Conditions

Performance Characteristics : Measured Output Jitter - EN 300 462-7-1 conformance

ETSI EN 300 462-7-1 Jitter Generation Requirements					ZL30410 Jitter Generation Performance		
	Interface	Jitter Measurement Filter	Limit in UI	Equivalent limit in time domain	TYP	Units	Notes
					C155 Clock Output		
1	STM-1 optical 155.52 Mbit/s	65kHz to 1.3MHz	0.1 Ulpp	0.643	0.325	nSp.p	
2		500Hz to 1.3MHz	0.5 Ulpp	3.215	0.448	nSp.p	
					C155 Clock Output		
3	STM-1 electrical 155.52 Mbit/s	65kHz to 1.3MHz	0.075 Ulpp	0.482	0.325	nSp.p	
4		500Hz to 1.3MHz	0.5 Ulpp	3.215	0.448	nSp.p	
					C19 Clock Output		
5	STM-1 optical 155.52 Mbit/s	65kHz to 1.3MHz	0.1 Ulpp	0.643	0.390	nSp.p	
6		500Hz to 1.3MHz	0.5 Ulpp	3.215	0.512	nSp.p	
					C19 Clock Output		
7	STM-1 electrical 155.52 Mbit/s	65kHz to 1.3MHz	0.075 Ulpp	0.482	0.390	nSp.p	
8		500Hz to 1.3MHz	0.5 Ulpp	3.215	0.512	nSp.p	

* Supply voltage and operating temperature are as per Recommended Operating Conditions

Performance Characteristics - Measured Output Jitter - Unfiltered*

	Characteristics	TYP (U_{Ipp})	TYP (n_{Spp})	Notes
1	C1.5o (1.544MHz)	0.0042	2.71	
2	C2o (2.048MHz)	0.0019	0.95	
3	C4o (4.096MHz)	0.0037	0.92	
4	C6o (6.312MHz)	0.0179	2.84	
5	C8o (8.192MHz)	0.0081	0.99	
6	C8.5o (8.592MHz)	0.0222	2.58	
7	C11o (11.184MHz)	0.0295	2.64	
8	C16o (16.384MHz)	0.0161	0.98	
9	C19o (19.44MHz)	0.0125	0.64	
10	C34o (34.368MHz)	0.0433	1.26	
11	C44o (44.736MHz)	0.0546	1.22	
12	C155o (155.52MHz)	0.0867	0.56	
13	F0o (8kHz)	NA	0.44	
14	F8o (8kHz)	NA	0.46	
15	F16o (8kHz)	NA	0.45	

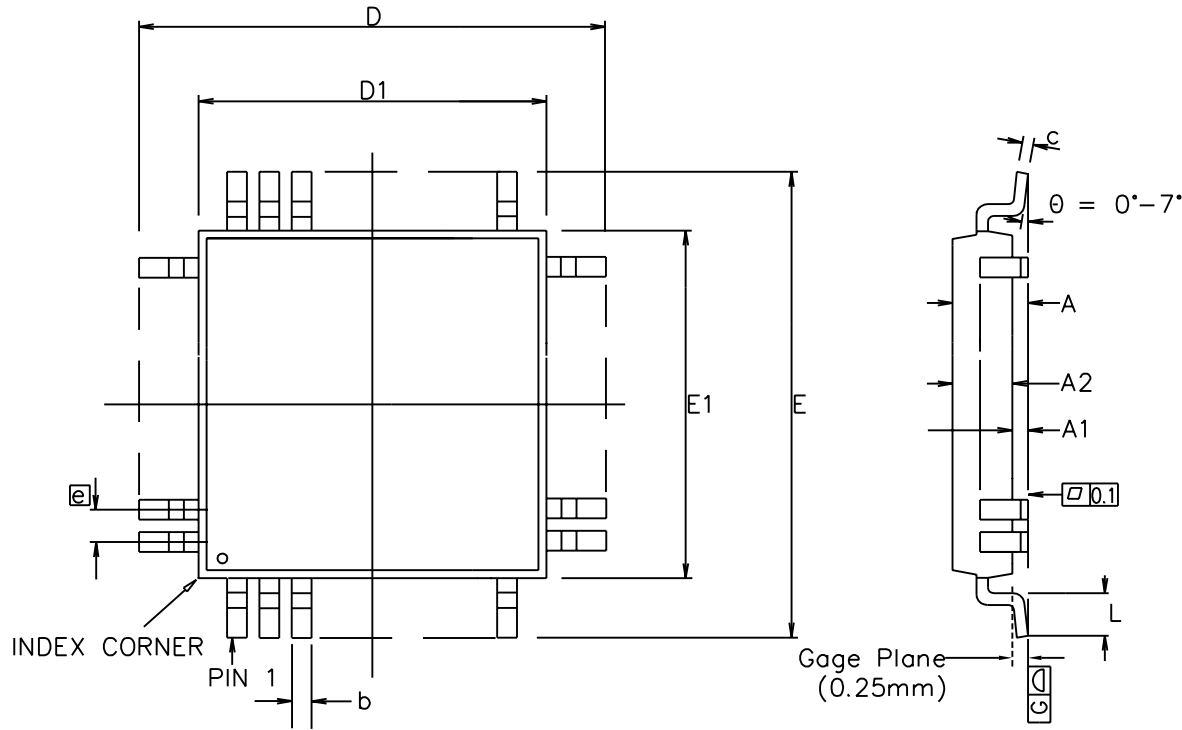

Symbol	Control Dimensions in millimetres		Altern. Dimensions in inches	
	MIN	MAX	MIN	MAX
A	---	1.60	0.002	0.063
A1	0.05	0.15	0.010	0.006
A2	1.35	1.45	0.053	0.057
D	16.00	BSC	0.630	BSC
D1	14.00	BSC	0.551	BSC
E	16.00	BSC	0.630	BSC
E1	14.00	BSC	0.551	BSC
L	0.45	0.75	0.018	0.030
e	0.65	BSC	0.026	BSC
b	0.22	0.38	0.009	0.015
c	0.09	0.20	0.004	0.008
Pin features				
N	80			
ND	20			
NE	20			
NOTE	SQUARE			

Conforms to JEDEC MS-026 BEC Iss. C

Notes:

1. Pin 1 indicator may be a corner chamfer, dot or both.
2. Controlling dimensions are in millimeters.
3. The top package body size may be smaller than the bottom package body size by a max. of 0.15 mm.
4. Dimension D1 and E1 do not include mould protrusion.
5. Dimension b does not include dambar protrusion.
6. Coplanarity, measured at seating plane G, to be 0.10 mm max.

This drawing supersedes 418/ED/51210/024 (Swindon)

© Zarlink Semiconductor 2002 All rights reserved.				
ISSUE	1	2	3	
ACN	201363	207143	212836	
DATE	28Oct96	14Jul99	21May02	
APPRD.				



		Package Code	QC
Previous package codes		Package Outline for 80 lead LQFP (14 x 14 x 1.4mm) 2.0mm Footprint	
GP / B			
		GPD00247	



**For more information about all Zarlink products
visit our Web Site at
www.zarlink.com**

Information relating to products and services furnished herein by Zarlink Semiconductor Inc. trading as Zarlink Semiconductor or its subsidiaries (collectively "Zarlink") is believed to be reliable. However, Zarlink assumes no liability for errors that may appear in this publication, or for liability otherwise arising from the application or use of any such information, product or service or for any infringement of patents or other intellectual property rights owned by third parties which may result from such application or use. Neither the supply of such information or purchase of product or service conveys any license, either express or implied, under patents or other intellectual property rights owned by Zarlink or licensed from third parties by Zarlink, whatsoever. Purchasers of products are also hereby notified that the use of product in certain ways or in combination with Zarlink, or non-Zarlink furnished goods or services may infringe patents or other intellectual property rights owned by Zarlink.

This publication is issued to provide information only and (unless agreed by Zarlink in writing) may not be used, applied or reproduced for any purpose nor form part of any order or contract nor to be regarded as a representation relating to the products or services concerned. The products, their specifications, services and other information appearing in this publication are subject to change by Zarlink without notice. No warranty or guarantee express or implied is made regarding the capability, performance or suitability of any product or service. Information concerning possible methods of use is provided as a guide only and does not constitute any guarantee that such methods of use will be satisfactory in a specific piece of equipment. It is the user's responsibility to fully determine the performance and suitability of any equipment using such information and to ensure that any publication or data used is up to date and has not been superseded. Manufacturing does not necessarily include testing of all functions or parameters. These products are not suitable for use in any medical products whose failure to perform may result in significant injury or death to the user. All products and materials are sold and services provided subject to Zarlink's conditions of sale which are available on request.

Purchase of Zarlink's I²C components conveys a licence under the Philips I²C Patent rights to use these components in an I²C System, provided that the system conforms to the I²C Standard Specification as defined by Philips.

Zarlink, ZL and the Zarlink Semiconductor logo are trademarks of Zarlink Semiconductor Inc.

Copyright 2003, Zarlink Semiconductor Inc. All Rights Reserved.

TECHNICAL DOCUMENTATION - NOT FOR RESALE
