

SMC3300-9085

**SMC Plug Solder Right Angle For RG405; 50Ω  
6GHz VSWR 1.2**

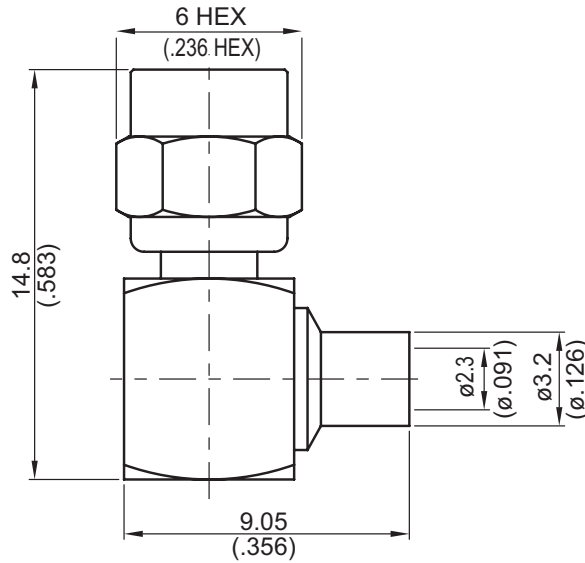

Parts	Material	Plating (Micro-inch)
Cover	Brass	Gold 4 Over Nickel-Phosphorus Alloy 80 Over Copper 20
Contact Pin	Beryllium Copper	Gold 4 Over Nickel-Phosphorus Alloy 80 Over Copper 20
Insulator	Teflon	
Body	Brass	Gold 4 Over Nickel-Phosphorus Alloy 80 Over Copper 20
Barrel	Brass	Gold 4 Over Nickel-Phosphorus Alloy 80 Over Copper 20
Coupling Nut	Brass	Gold 4 Over Nickel-Phosphorus Alloy 80 Over Copper 20

Weight: 2.52 g

Suitable Cables: Semi-rigid.085

**This part number complies with RoHS.**





**Notice: JYEBAO reserves the right to make modifications deemed appropriate.**

SMC	SMC3300-9085																				
<div style="border: 1px solid black; padding: 2px; margin-bottom: 5px;">Interface</div> MIL-STD-348B																					
<div style="border: 1px solid black; padding: 2px; margin-bottom: 5px;">Electrical Data</div> <table style="width: 100%; border-collapse: collapse;"> <tr> <td style="width: 50%;">Impedance</td> <td style="width: 50%;">50Ω</td> </tr> <tr> <td>Frequency range</td> <td>DC to 6GHz</td> </tr> <tr> <td>VSWR</td> <td>≤ 1.2 (DC to 6GHz)</td> </tr> <tr> <td>Insertion loss</td> <td>≤ 0.1 x √f(GHz)dB</td> </tr> <tr> <td>Insulation resistance</td> <td>≥ 10000MΩ</td> </tr> <tr> <td>Contact resistance inner conductor</td> <td>≤ 5mΩ</td> </tr> <tr> <td>Contact resistance outer conductor</td> <td>≤ 2.5mΩ</td> </tr> <tr> <td>Dielectric withstanding voltage (at sea level)</td> <td>750 V rms</td> </tr> <tr> <td>Working voltage (at sea level)</td> <td>250 V rms</td> </tr> <tr> <td>RF leakage</td> <td>≥ 90dB to 1GHz</td> </tr> </table>		Impedance	50Ω	Frequency range	DC to 6GHz	VSWR	≤ 1.2 (DC to 6GHz)	Insertion loss	≤ 0.1 x √f(GHz)dB	Insulation resistance	≥ 10000MΩ	Contact resistance inner conductor	≤ 5mΩ	Contact resistance outer conductor	≤ 2.5mΩ	Dielectric withstanding voltage (at sea level)	750 V rms	Working voltage (at sea level)	250 V rms	RF leakage	≥ 90dB to 1GHz
Impedance	50Ω																				
Frequency range	DC to 6GHz																				
VSWR	≤ 1.2 (DC to 6GHz)																				
Insertion loss	≤ 0.1 x √f(GHz)dB																				
Insulation resistance	≥ 10000MΩ																				
Contact resistance inner conductor	≤ 5mΩ																				
Contact resistance outer conductor	≤ 2.5mΩ																				
Dielectric withstanding voltage (at sea level)	750 V rms																				
Working voltage (at sea level)	250 V rms																				
RF leakage	≥ 90dB to 1GHz																				
<div style="border: 1px solid black; padding: 2px; margin-bottom: 5px;">Mechanical Data</div> <table style="width: 100%; border-collapse: collapse;"> <tr> <td style="width: 50%;">Recommended coupling nut torque</td> <td style="width: 50%;">2.2 to 3.1 inch lbs</td> </tr> <tr> <td>Coupling proof torque</td> <td>6.2 inch lbs</td> </tr> <tr> <td>Coupling nut retention force</td> <td>≥ 33.72 lbs</td> </tr> <tr> <td>Contact captivation-axial</td> <td>≥ 2.25 lbs</td> </tr> <tr> <td>Durability (mating)</td> <td>≥ 500</td> </tr> </table>		Recommended coupling nut torque	2.2 to 3.1 inch lbs	Coupling proof torque	6.2 inch lbs	Coupling nut retention force	≥ 33.72 lbs	Contact captivation-axial	≥ 2.25 lbs	Durability (mating)	≥ 500										
Recommended coupling nut torque	2.2 to 3.1 inch lbs																				
Coupling proof torque	6.2 inch lbs																				
Coupling nut retention force	≥ 33.72 lbs																				
Contact captivation-axial	≥ 2.25 lbs																				
Durability (mating)	≥ 500																				
<div style="border: 1px solid black; padding: 2px; margin-bottom: 5px;">Environmental Data</div> <table style="width: 100%; border-collapse: collapse;"> <tr> <td style="width: 50%;">Temperature range</td> <td style="width: 50%;">-65°C to +165°C</td> </tr> <tr> <td>Thermal shock</td> <td>MIL-STD-202, Method 107, Condition B</td> </tr> <tr> <td>Moisture resistance</td> <td>MIL-STD-202, Method 106</td> </tr> <tr> <td>Corrosion</td> <td>MIL-STD-202, Method 101, Condition B</td> </tr> <tr> <td>RoHS</td> <td>Compliant</td> </tr> </table>		Temperature range	-65°C to +165°C	Thermal shock	MIL-STD-202, Method 107, Condition B	Moisture resistance	MIL-STD-202, Method 106	Corrosion	MIL-STD-202, Method 101, Condition B	RoHS	Compliant										
Temperature range	-65°C to +165°C																				
Thermal shock	MIL-STD-202, Method 107, Condition B																				
Moisture resistance	MIL-STD-202, Method 106																				
Corrosion	MIL-STD-202, Method 101, Condition B																				
RoHS	Compliant																				
<div style="border: 1px solid black; padding: 2px; margin-bottom: 5px;">Tooling</div> <table style="width: 100%; border-collapse: collapse;"> <tr> <td style="width: 50%;">Soldering fixture</td> <td style="width: 50%;">ST-008</td> </tr> <tr> <td>Insert for .085 semi-rigid cable</td> <td>ST-009</td> </tr> <tr> <td>Locator tool</td> <td>ST-011</td> </tr> </table>		Soldering fixture	ST-008	Insert for .085 semi-rigid cable	ST-009	Locator tool	ST-011														
Soldering fixture	ST-008																				
Insert for .085 semi-rigid cable	ST-009																				
Locator tool	ST-011																				

Notice: JYEBAO reserves the right to make modifications deemed appropriate.

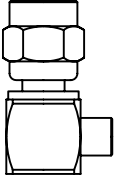
# JYE BAO CO., LTD.

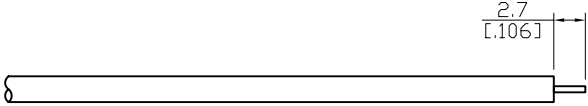
## CABLE ASSEMBLY INSTRUCTION

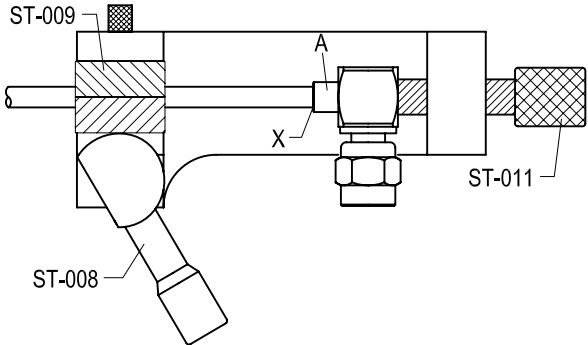
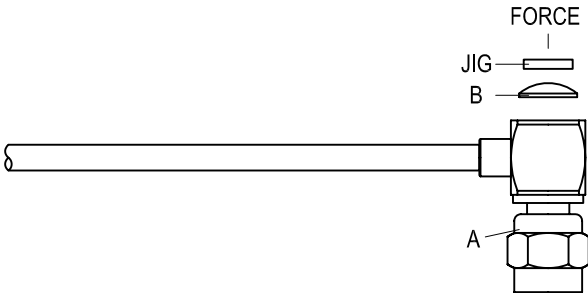
SMC3300-9085	DATE	2017/10/20	REV	—
<div style="display: flex; justify-content: space-around; align-items: center;"> <div style="text-align: center;"> <p>A</p>  <p>BODY</p> </div> <div style="text-align: center;"> <p>B</p>  <p>COVER</p> </div> </div>				
DIAGRAM		ASSEMBLY INSTRUCTION		
		<p>Step 1: STRIP AS SHOWN.</p>		
		<p>Step 2: SLIDE CENTER CONDUCTOR ON THE CONTACT PIN OF CONNECTOR " A " AND SOLDER IN " Y ".</p>		
		<p>Step 3: USE SOLDERING FIXTURE " ST-008 " , INSERT TOOL " ST-009 " AND LOCATOR TOOL " ST-011 " TO FIX THE CONNECTOR. SOLDER IN " X ".</p>		
		<p>Step 4: PRESS ON THE TOP OF " B " WITH JIGS.</p>		
<p>This part number complies with RoHS.          Notice: JYEBAO reserves the right to make modifications deemed appropriate.</p>				
APPROVED	CHECKED	DRAWING <i>Albert</i>		

# SMC3300-9085

S11

