

Si photodiode with preamp S5590, S5591

Photodiode and preamp integrated with feedback resistance and capacitance

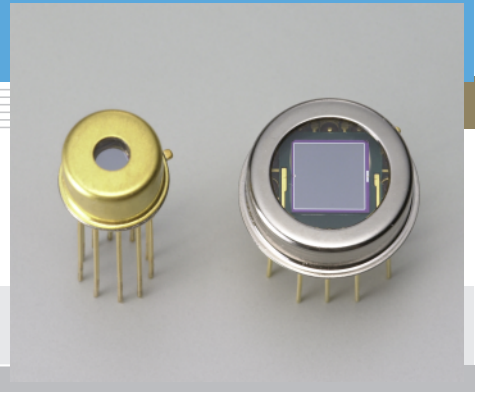

S5590, S5591 are low-noise light sensors consisting of a large area Si photodiode, op amp, and feedback resistance and capacitance, all integrated into a small package. By simply connecting to a power supply, S5590 and S5591 can be used in low-light-level measurement such as spectrophotometry.

Features

- Si photodiode for UV to near IR precision photometry
- Small package with quartz window
S5590: TO-5
S5591: TO-8
- FET input operational amplifier with low power dissipation
- Built-in $R_f=1\text{ G}\Omega$ and $C_f=5\text{ pF}$
- Variable gain with an externally connected resistor
- Low noise and NEP
- Guard ring structure for low level signal

Applications

- Spectrophotometry
- General-purpose optical measurement

General ratings / Absolute maximum ratings

Type No.	Dimensional outline/ Window material *	Active area size (mm)	Package	Number of terminals	Absolute maximum ratings				
					Supply voltage (op amp) V_{CC} (V)	Reverse voltage (photodiode) V_R (V)	Power dissipation P (mW)	Operating temperature T_{opr} ($^{\circ}\text{C}$)	Storage temperature T_{stg} ($^{\circ}\text{C}$)
S5590	①/Q	2.4×2.4	TO-5	10	± 18	5	500	-20 to +60	-30 to +80
S5591	②/Q	5.8×5.8	TO-8	12					

Electrical and optical characteristics (Typ. $T_a=25\text{ }^{\circ}\text{C}$, $V_{CC}=\pm 15\text{ V}$, $R_L=1\text{ M}\Omega$, unless otherwise noted)

Type No.	Spectral response range λ (nm)	Peak sensitivity wavelength λ_p (nm)	Feedback resistance R_f (built-in) ($\text{G}\Omega$)	Feedback capacitance C_f (built-in) (pF)	Photo sensitivity S (V/nW)		Output noise voltage V_n Dark state $f=10\text{ Hz}$ ($\mu\text{V}_{rms}/\text{Hz}^{1/2}$)	Noise equivalent power NEP $\lambda=\lambda_p$ (fW/Hz $^{1/2}$)		Output offset voltage V_{os} Dark state (mV)	Cut-off frequency f_c (MHz)	Supply current I_s Dark state (mA)
					$\lambda=200\text{ nm}$	$\lambda=\lambda_p$		$f=10\text{ Hz}$	$f=20\text{ Hz}$			
					S5590	190 to 1100		960	1			
S5591							8	16	17			

* Window material Q: quartz glass

Figure 1 Spectral response

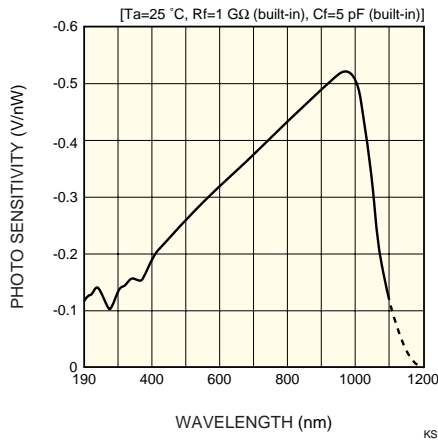

The built-in feedback resistance and capacitance of S5590 and S5591 are 1 GΩ and 5 pF, respectively. This combination provides a sensitivity of about -0.1 to -0.5 V/nW in the wavelength range of 190 to 1100 nm.

Figure 2 Frequency response

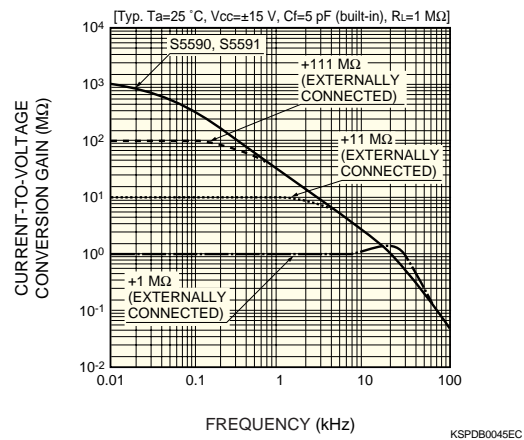

The current-to-voltage conversion gain can be varied by connecting an external feedback resistor between pins 4 and 6 for S5590, and between pins 9 and 12 for S5591. Figure 2 shows the frequency response characteristics of S5590 and S5591 with or without an externally connected feedback resistor. Because S5590 and S5591 have a built-in resistor of 1 GΩ, for example the total feedback resistance will be converted to 100 MΩ by externally connecting a resistor of 111 MΩ. Choose the desired constant according to the incident light level to be detected.

Note) If the external feedback resistor is 1 MΩ or less, gain peaking may occur in the frequency response. Therefore, be sure to connect a matched feedback capacitor for phase compensation.

Figure 3 Output noise voltage vs. frequency (S5590)

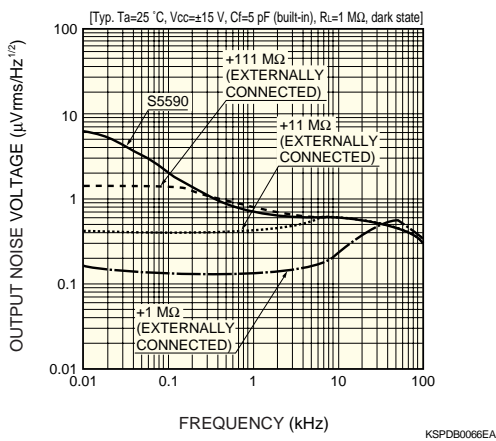

Output noise voltage and NEP (noise equivalent power) characteristics allow you to check whether the device can detect the low-level light you want to measure. Since NEP is given by the equation (1) as shown at the right, NEP at wavelengths other than λp can be easily calculated from Figure 1 and Figures 5 to 6.

Note) When S5590 and S5591 are used only with the internal current-to-voltage gain, it is recommended that the "-IN" lead (pin 6 for S5590; pin 9 for S5591) be cut off to a short length in order to reduce the influence of external noise as much as possible.

Figure 4 Output noise voltage vs. frequency (S5591)

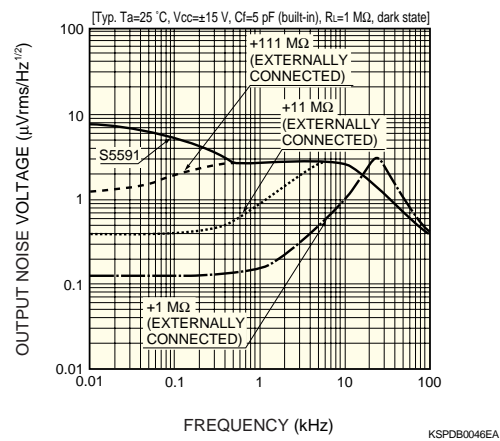

$$NEP(f, \lambda) = \frac{Vn(f)}{G_{I-V}(f) \cdot S_{Si}(\lambda)} = \frac{NEP(f, \lambda_p) \cdot S(\lambda_p)}{S(\lambda)} \dots (1)$$

- NEP (f, λ) : NEP at frequency and wavelength to be detected
- NEP (f, λp) : NEP at peak wavelength (See Figures 5 and 6.)
- G_{I-V}(f) : Current-to-voltage conversion gain (See Figure 2.)
- S_{Si} (λ) : Sensitivity of Si photodiode
- S (λ) : Sensitivity of S5590 and S5591 (See Figure 1.)
- S (λp) : Sensitivity of S5590 and S5591 at peak wavelength, 0.5 V/nW
- Vn (f) : Output noise voltage (See Figure 3 and 4.)

Figure 5 NEP vs. frequency (S5590)

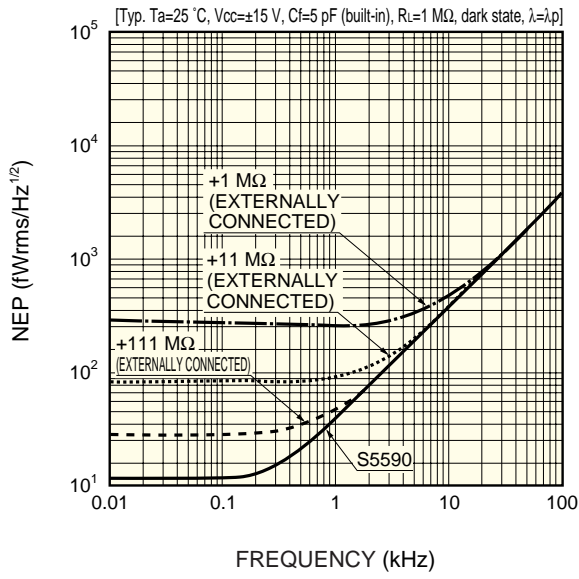

KSPDB0067EA

Figure 6 NEP vs. frequency (S5591)

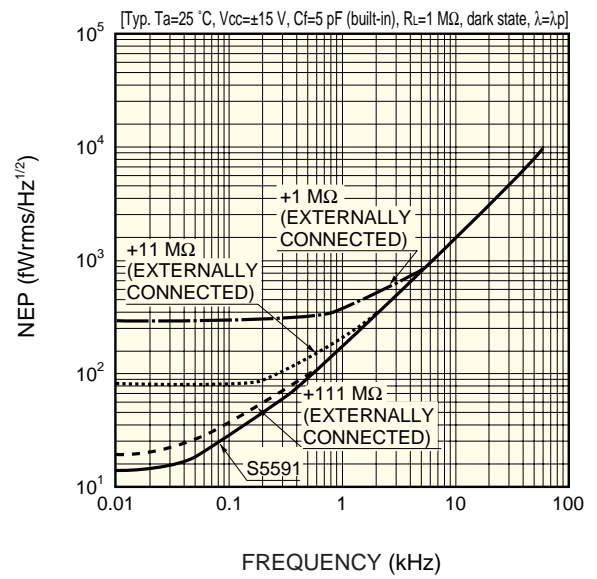

KSPDB0047EA

Figure 7 External connection example (S5590)

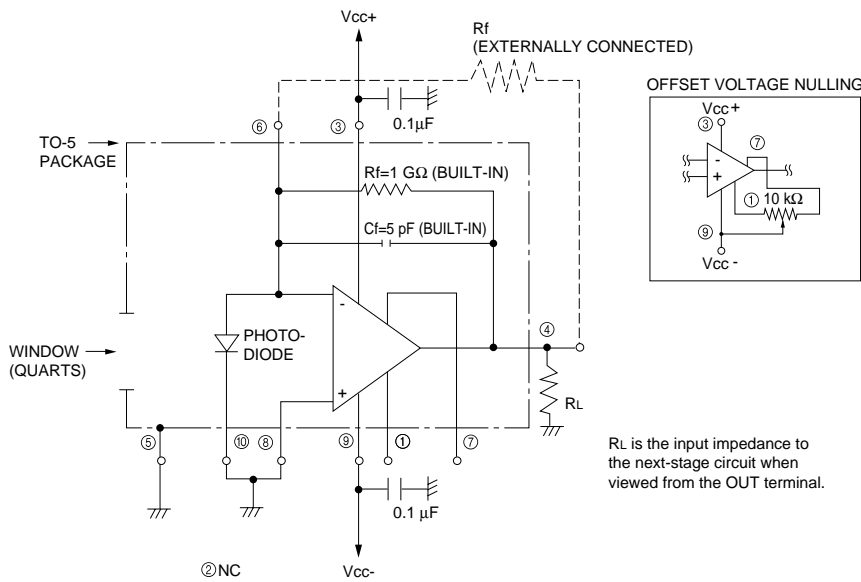
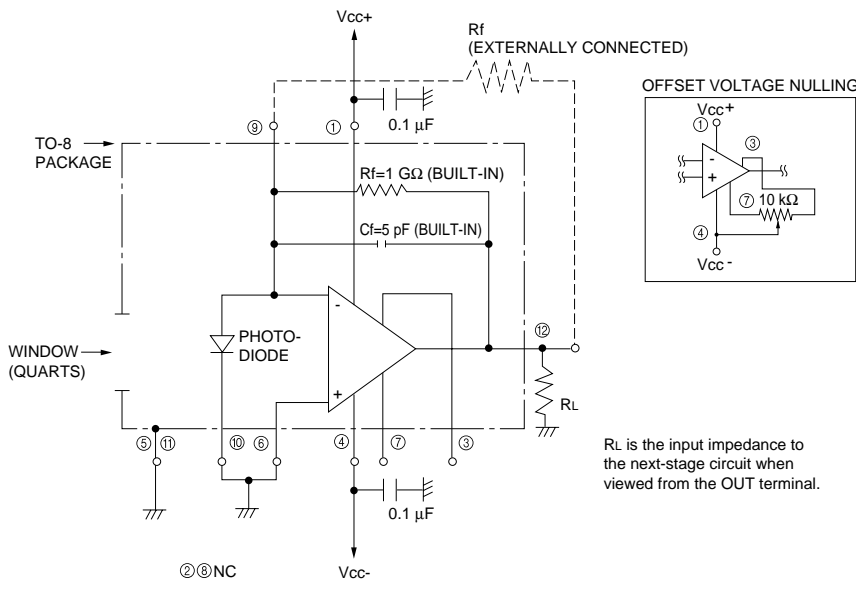

Figure 8 External connection example (S5591)



S5590 and S5591 use a package with the guard ring effect provided. To make it effective during measurement, the package leads (pin 5 for S5590; pins 5 and 11 for S5591) should be connected to the ground line.

When a feedback resistor is externally connected, it is necessary to provide a guard ring on the circuit board or to provide a teflon standoff for the leads.

The output offset should be adjusted using a $10 \text{ k}\Omega$ variable resistor under completely light-shielded conditions.

Note) A tantalum or ceramic capacitor of 0.1 to $10 \mu\text{F}$ must be connected to the supply voltage leads (pins 3 and 9 for S5590; pins 1 and 4 for S5591) as a bypass capacitor used to prevent the device from oscillation.

Figure 9 Dimensional outlines (unit: mm)

① S5590

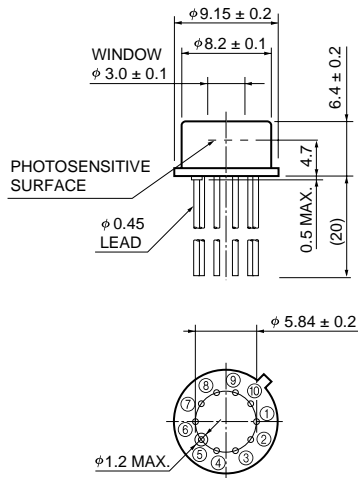

- ① OFFSET
- ② NC
- ③ Vcc+
- ④ OUT
- ⑤ CASE
- ⑥ -IN
- ⑦ OFFSET
- ⑧ +IN
- ⑨ Vcc-
- ⑩ PD (CATHODE)

② S5591

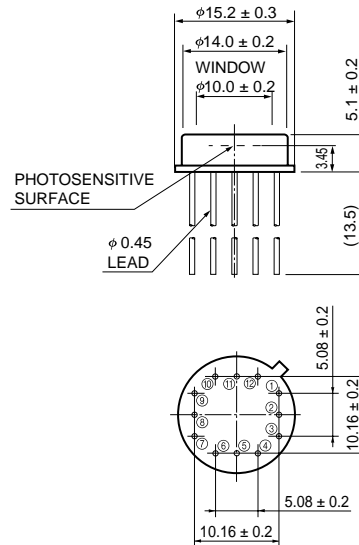

- ① Vcc+
- ② NC
- ③ OFFSET
- ④ Vcc-
- ⑤ CASE
- ⑥ +IN
- ⑦ OFFSET
- ⑧ NC
- ⑨ -IN
- ⑩ PD (CATHODE)
- ⑪ CASE
- ⑫ OUT

KSPDA0067EB

KSPDA0068EB

Precautions for Use

S5590 and S5591 may be damaged or their performance may deteriorate by such factors as electro static discharge from the human body, surge voltages from measurement equipment, leakage voltages from soldering irons and packing materials. As a countermeasure against electro static discharge, the device, operator, work place and measuring jigs must all be set at the same potential. The following precautions must be observed during use:

- To protect the device from electro static discharge which accumulate on the operator or the operator's clothes, use a wrist strap or similar tools to ground the operator's body via a high impedance resistor (1 M Ω).
- A semiconductive sheet (1 M Ω to 100 M Ω) should be laid on both the work table and the floor in the work area.
- When soldering, use an electrically grounded soldering iron with an isolation resistance of more than 10 M Ω .
- For containers and packing, use of a conductive material or aluminum foil is effective. When using an antistatic material, use one with a resistance of 0.1 M Ω /cm² to 1 G Ω /cm².

HAMAMATSU

Information furnished by HAMAMATSU is believed to be reliable. However, no responsibility is assumed for possible inaccuracies or omissions. Specifications are subject to change without notice. No patent rights are granted to any of the circuits described herein. ©2001 Hamamatsu Photonics K.K.

HAMAMATSU PHOTONICS K.K., Solid State Division

1126-1 Ichino-cho, Hamamatsu City, 435-8558 Japan, Telephone: (81) 053-434-3311, Fax: (81) 053-434-5184, <http://www.hamamatsu.com>

U.S.A.: Hamamatsu Corporation: 360 Foothill Road, P.O.Box 6910, Bridgewater, N.J. 08807-0910, U.S.A., Telephone: (1) 908-231-0960, Fax: (1) 908-231-1218

Germany: Hamamatsu Photonics Deutschland GmbH: Arzbergerstr. 10, D-82211 Herrsching am Ammersee, Germany, Telephone: (49) 08152-3750, Fax: (49) 08152-2658

France: Hamamatsu Photonics France S.A.R.L.: 8, Rue du Saule Trapu, Parc du Moulin de Massy, 91882 Massy Cedex, France, Telephone: 33-(1) 69 53 71 00, Fax: 33-(1) 69 53 71 10

United Kingdom: Hamamatsu Photonics UK Limited: 2 Howard Court, 10 Tewin Road, Welwyn Garden City, Hertfordshire AL7 1BW, United Kingdom, Telephone: (44) 1707-294888, Fax: (44) 1707-325777

North Europe: Hamamatsu Photonics Norden AB: Smidesvägen 12, SE-171 41 Solna, Sweden, Telephone: (46) 8-509-031-00, Fax: (46) 8-509-031-01

Italy: Hamamatsu Photonics Italia S.R.L.: Strada della Moia, 1/E, 20020 Arese, (Milano), Italy, Telephone: (39) 02-935-81-733, Fax: (39) 02-935-81-741