

M1280 Series

Crystal Oscillators HCMOS/TTL 5V

Thru-Hole/Gull Wing; Commercial: 0° to 70°

Fixed Frequency, 1 KHz to 175 MHz

Features

- Frequency from 1 KHz to 175 MHz
- Choice of thru-hole packages
 - DIL Full Size ("M")
 - Half Size DIL ("H")
 - Gull Wing SMD
- Tristate and "Hard Zero" options accommodate ATE
- Very low power when tristated
- Start up time less than 5 ms
- Stability options from +/-100 ppm to +/- 20 ppm
- Guaranteed start-up with ramping DC Supply
- 45/55 symmetry available
- Internal bypass capacitor delivers superior waveform characteristics
- Jitter from positive edge to positive edge is 50 ps RMS max

Typical Applications

- Any thru-hole PCB that requires a standard HCMOS/TTL 5V clock, including microprocessors and microcontrollers

Description

Valpey Fisher's thru-hole oscillators embody 25 years of design and manufacturing know-how. They are available in full-size and half size packages, all hermetically sealed with welded stainless steel cover. These 5V thru-hole oscillators are designed for everyday stresses of 0°C to 70°C operation and extended frequency selection of 1 KHz to 175 MHz. Higher (5V) operation ensures superior output loading and faster rise/fall times characteristics.

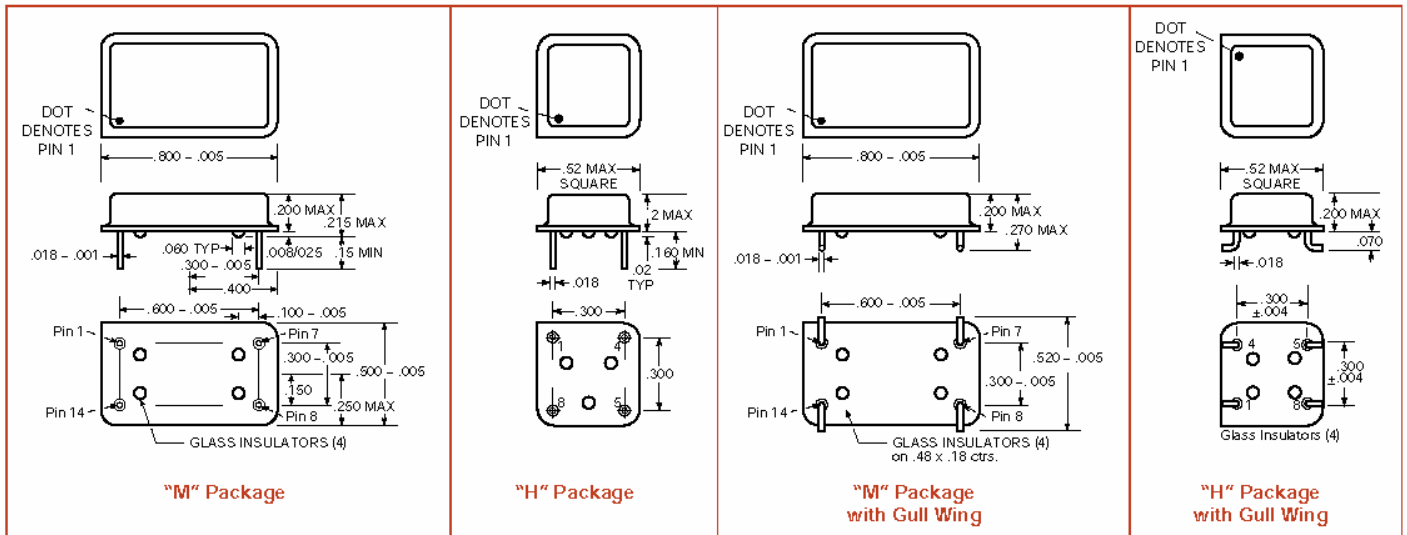

M1280 Series

Crystal Oscillators HCMOS/TTL 5V

Thru-Hole/Gull Wing; Commercial: 0° to 70°C

Fixed Frequency, 1 KHz to 175 MHz

ELECTRICAL SPECIFICATIONS

Frequency Range

Fixed Output 1 KHz to 175 MHz
 Tristate 32.768 to 175 MHz
 "Hard Zero" 62.5 KHz to 125 MHz

Frequency Stability

Includes calibration at 25°C, operating temperature, change of input voltage, change of load, shock and vibration

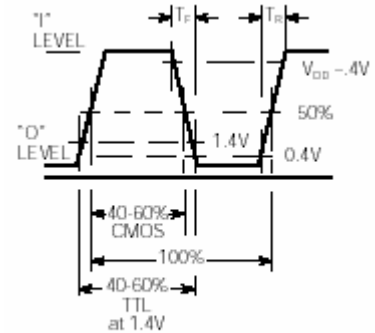

WAVEFORMS

	MIN	TYP	MAX	UNITS
Input Voltage, V_{DD}	4.50	5.0	5.50	volts

Input Current,

1 KHz to 10 MHz		10	20	mA
10.1 to 25 MHz		20	35	mA
25.1 to 50 MHz		25	45	mA
50.1 to 75 MHz		40	55	mA
75.1 to 125 MHz		50	60	mA
100.1 to 175 MHz		55	65	mA

Output Levels,

"0" Level, sinking 16 mA			0.4	volts
"1" Level, TTL	2.4	4.6		volts
CMOS, sourcing 8 mA	V _{DD} -4			volts

Rise and Fall Times,

TTL, from 0.8 to 2.4V		2.4	4	ns
HCMOS, 15 pf, 20 to 80%				
1 KHz to 75 MHz		2.5	4	ns
75.1 to 175 MHz		1.5	2	ns
HCMOS, 30 pf, 20 to 80%				
1 KHz to 125MHz		4.0	6	ns
HCMOS, 50 pf, 20 to 80%				
1KHz to 75 MHz		4.0	6	ns

Jitter, Positive Edge to positive edge

50 Ps RMS

Symmetry

10 TTL, @ 1.4V	45/55	40/60	percent
Depending on model		or 45/55	percent
HCMOS, @ 50%	45/55	40/60	percent
Depending on model		or 45/55	percent

Aging

First year	3	ppm
After first year	1	ppm/yr

Input Requirements for Pin 1:

"1": On - Pin 1 may float or 2.4V min., sourcing 400 microAmp
 "0": Disable or Tristate - Pin 1 requires 0.4V, sinking 400 microAmp

	FULL SIZE	HALF SIZE	M1280's H1280's	M1290's,"Hard-Zero" M3290's or Tristate for 3290's
PIN	1	1	NOT USED	Floating or "1": Oscillator runs Ground or "0": Hard "0" for M1290's or Tristate for 3290's
PIN	7	4	Ground and Case	
PIN	8	5	Output	
PIN	14	8	5V, V _{DD}	

FIXED OUTPUT		TRISTATE		HARD ZERO	Frequency Stability
40/60 Symmetry	45/55 Symmetry	40/60 Symmetry	45/55 Symmetry	40/60 Symmetry	
1280	1286	3290	3296	M1290	+/-100ppm
1281	1991	3291	3991	M1291	+/-25ppm
1282	1992	3292	3992	M1292	+/-50ppm
1288	1998	3298	3998	M1298	+/-20ppm
1289	1999	3299	3999	M1299	+/-32ppm

M1280 Series
Crystal Oscillators HCMOS/TTL 5V
Thru-Hole/Gull Wing; Commercial: 0° to 70°C
Fixed Frequency, 1 KHz to 175 MHz

ENVIRONMENTAL SPECIFICATIONS

Temperature

Operating 0° to 70°C
 Storage -55° to +125°C

Shock- 1000 Gs, 0.35 ms, ½ sine wave, 3 shocks in each plane

Vibration- 10-2000 Hz of .06" d.a. or 20 Gs, whichever is less

Humidity- Resistant to 85° R.H. at 85°C

MECHANICAL SPECIFICATIONS

Leak- MIL STD 883, Method 1014, Condition A1

Pins- Kovar, nickel plated with 60/40 solder coat

Bend test- Will withstand two bends of 90° from reference

Header- Steel, with nickel plate

Case- Stainless steel, type 304

Marking- Epoxy ink or laser engraved

Resistance to Solvents- MIL STD 202, Method 215

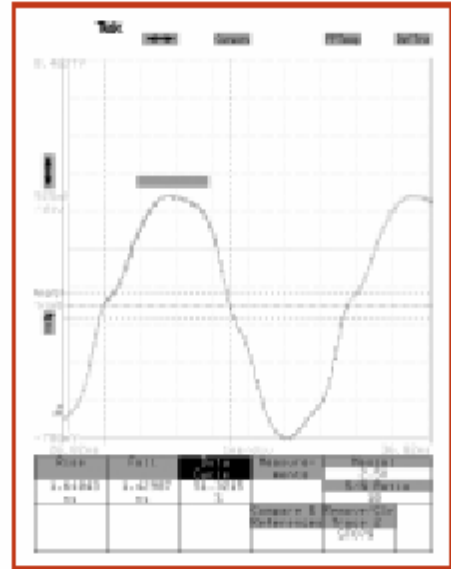

Fig. 1 M1286-148.26M with 10pf load
 Duty Cycle is 51.3% at $V_{DD}/2$

HOW TO ORDER

For Part Number, put package type before model number, and add frequency in MHz, for example:

H 3290 - 66.66 M

"M" is full size DIL
 "H" is half size DIL

"3290" is model type

"66.66 M" frequency in MHz

Leave blank for straight leads
 Add "G" for gullwing

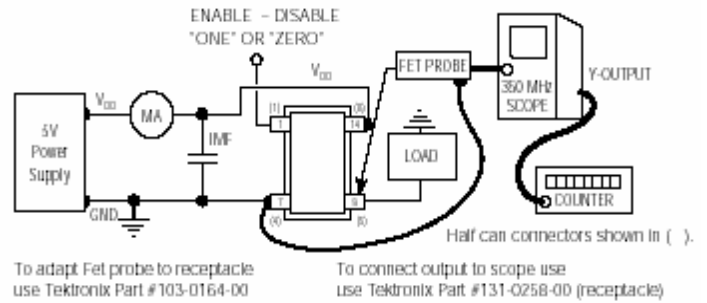

ALL OSCILLATORS HAVE INTERNAL BYPASS CAPACITORS

TEST CIRCUIT