

Speech Circuit with Line-Powered Loudspeaker Amplifier

Description

The electronic speech circuit U4050B is a linear integrated circuit for use in telephone sets. It replaces the hybrid transformer, sidetone equivalent and ear protection rectifiers.

The circuit is line powered and contains all components necessary for amplification of signals and adaptation to the line. An integrated loudspeaker amplifier allows loudhearing operation.

Features

- Integrated amplifier for loudhearing operation
- Anticlippping for loudspeaker amplifier
- Supply voltages for all functional blocks of a subscriber set
- Adjustable DC characteristics
- Adjustable sending and receiving amplification
- Automatic line loss compensation
- Symmetrical output of earpiece amplifier
- Built-in ear protection
- Symmetrical input of microphone amplifier
- Adjustable sidetone suppression independent of sending and receiving amplification

- DTMF and MUTE inputs
- Anticlippping in transmit direction
- Squelch
- Integrated transistor for short circuiting the line voltage
- Power down
- Operation possible at line currents above 10 mA

Benefits

- Independent adjustment of transmit gain, receive gain and sidetone suppression
- Low number of external components

Block Diagram

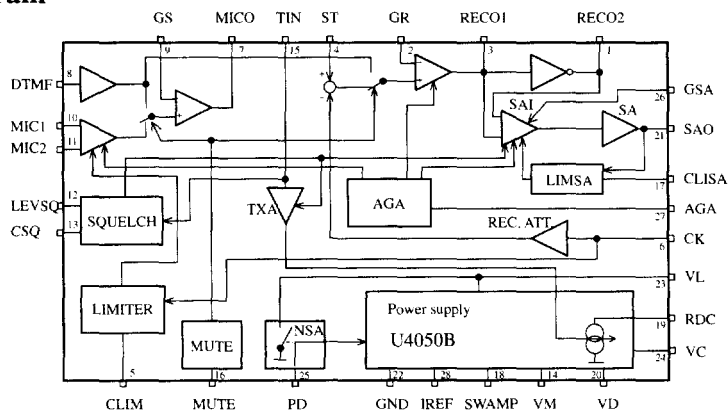

Figure 1. Block diagram

Ordering Information

Extended Type Number	Package	Remarks
U4050B-AFL	SO28	
U4050B-AFLG3	SO28	Taped and reeled

Pin Description

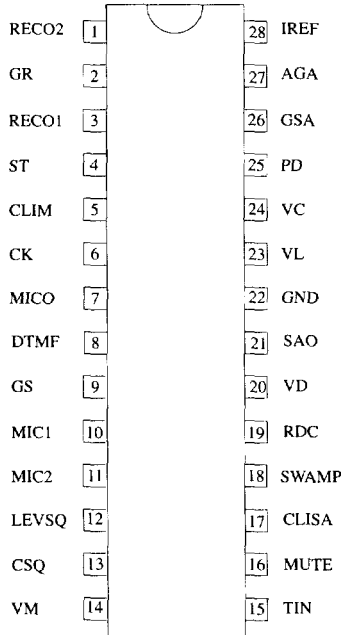

Figure 3. Pinning S028

14052

Pin	Symbol	Function
1 3	RECO2, RECO1	Symmetrical outputs of receiving amplifier
2	GR	A resistor connected from this pin to V_M (AC coupled) sets the receiving amplification at the circuit
4	ST	Input of sidetone amplifier
5	CLIM	Time constant of antialiasing in transmit patch
6	CK	Input of receiving path
7	MICO	Output of microphone preamplifier
8	DTMF	Input for DTMF signals (ac coupled). In Mute condition a small portion of the signal at this pin is monitored to the receiver output.
9	GS	A resistor from this pin to V_M sets the amplification of microphone and DTMF signals.
10	MIC1	Inverting input of microphone amplifier

Pin	Symbol	Function
11	MIC2	Non-inverting input of microphone amplifier
12	LEVSQ	Input for setting the switching level of the squelch circuit
13	CSQ	Time constant of the squelch function
14	VM	Reference node for microphone, earphone and loudspeaker amplifier. Supply for electret microphone set to $V_L/2$.
15	TIN	Input of intermediate transmit stage
16	MUTE	Active high input to switch the circuit into DTMF condition.
17	CLISA	Time constant of antialiasing of speaker amplifier.
18	SWAMP	A resistor connected from this pin to ground converts the excess line current into heat in order to prevent the IC from thermal destruction at high line currents
19	RDC	A small resistor connected from this pin to V_L sets the slope of the characteristic and also affects the line length equalization characteristics and the line current at which the loudspeaker amplifier is switched on.
20	VD	Unregulated supply voltage for peripheral circuits (dialers, microprocessors, etc.). Output current capability and output voltage increase with line current.
21	SAO	Output of loudspeaker amplifier.
22	GND	Reference point for DC and AC output signals
23	VL	Line voltage
24	VC	The internal equivalent inductance of the circuit is proportional to the value of the capacitor at this pin. A resistor connected to ground may be used to reduce the line voltage.
25	PD	Active high input for reducing the current consumption of the circuit. Simultaneously V_L is shorted by an internal switch.
26	GSA	Current input for setting the gain of the speaker amplifier
27	AGA	Automatic gain adjustment with line current. A resistor connected from this pin to V_L sets the starting point. Maximum gain change is 6 dB.
28	IREF	Internal reference current generation

Absolute Maximum Ratings

Parameters	Symbol	Value	Unit
Line current	I_L	140	mA
Line voltage	V_L	15	V
Junction temperature	T_j	150	°C
Ambient temperature	T_{amb}	-25 to +75	°C
Storage temperature	T_{stg}	-55 to +150	°C
Total power dissipation ($T_{amb} = 60^\circ\text{C}$, SO28)	P_{tot}	750	mW

Thermal Resistance

Parameters	Symbol	Value	Unit
Junction ambient SO28	R_{thJA}	120	K/W

Electrical Characteristics

Test conditions unless otherwise specified: $f = 1 \text{ kHz}$, $0 \text{ dBm} = 775 \text{ V}_{rms}$, $I_M = 0.3 \text{ mA}$, $I_D = 2 \text{ mA}$, $RC = 130 \text{ k}\Omega$, $T_{amb} = 25^\circ\text{C}$, $R_{GSA} = 560 \text{ k}\Omega$, $Z_H = Z_M = 68 \text{ nF}$, Pin AGA open

Parameters	Test Conditions / Pins	Symbol	Min.	Typ.	Max.	Unit
DC characteristics see figure 4						
DC voltage drop over circuit	$I_L = 2 \text{ mA}$	V_L		1.9		V
	$I_L = 15 \text{ mA}$	V_L	4.8	5.2	5.6	V
	$I_L = 19 \text{ mA}$	V_L		5.4		V
	$I_L = 30 \text{ mA}$	V_L		6.0		V
	$I_L = 100 \text{ mA}$	V_L		9.5		V
Transmission amplifier see figures 5 and 11						
Adjustment range of transmit gain	$I_L = 15 \text{ mA}$	G_S	40	48	56	dB
Transmitting amplification	$I_L = 15 \text{ mA}$	G_S	47.75	48.25	48.75	dB
Frequency response	$I_L \geq 15 \text{ A}$, $C_L = 4.7 \text{ nF}$ $f = 300 \text{ to } 3400 \text{ Hz}$	ΔG_S			± 0.5	dB
Gain change with current	Pin AGA open $I_L = 15 \text{ to } 100 \text{ mA}$	ΔG_S			± 0.5	dB
Gain deviation	$T_{amb} = -10 \text{ to } +60^\circ\text{C}$ $I_L = 15 \text{ mA}$	ΔG_S			± 0.5	dB
CMRR of microphone amplifier		CMRR	60	80		dB
Input resistance of MIC amplifier		R_i	45	60	80	$\text{k}\Omega$
Distortion at line	$I_L > 15 \text{ mA}$ $V_L = 775 \text{ mV}_{rms}$	d_s			2	%
Maximum output voltage	$I_L > 19 \text{ mA}$ $d < 5\%$ $V_{mic} = 10 \text{ m}$	$V_{I\max}$	1.8	3	4.2	dBm
Noise at line psophometrically weighted	$I_L > 15 \text{ mA}$ $G_S = 48 \text{ dB}$	n_o		-80	-72	dBmp
Anticlippping attack time	$V_{mic} = 20 \text{ mV}$ $C = 470 \text{ nF}$			0.5		ms
Release time	Each 3 dB overdrive			9		ms

Parameters	Test Conditions / Pins	Symbol	Min.	Typ.	Max.	Unit
Gain at low operating current	$I_L = 10 \text{ mA}$, $I_D = 1 \text{ mA}$ $RC = 68 \text{ k}\Omega$ $V_{mic} = 1 \text{ mV}$ $I_M = 0 \text{ mA}$	G_S	47		50	dB
Distortion at low operating current	$I_L = 10 \text{ mA}$, $I_M = 0 \text{ mA}$ $I_D = 1 \text{ mA}$, $RC = 68 \text{ k}\Omega$ $V_{mic} = 10 \text{ mV}$	ds			6	%
Line loss compensation	$I_L = 100 \text{ mA}$ $R_{AGA} = 7.5 \text{ k}\Omega$	ΔG_{SI}	-5	-6	-7	dB
Mute suppression	$I_L \geq 15 \text{ mA}$ $V_{mute} = 1.5 \text{ V}$	G_{SM}	60			dB
Receiving amplifier see figures 6 and 8						
Adjustment range of receiving gain	$I_L \geq 15 \text{ mA}$ differential	G_R	-8		+8	dB
Receiving amplification	$I_L = 15 \text{ mA}$ differential	G_R	-1	-0.5	0	dB
Amplification of DTMF signal from DTMF IN to RECO 1/2	$I_F \geq 15 \text{ mA}$ Mute active	G_{RM}	-15	-12	-9	dB
Frequency response	$I_L > 15 \text{ mA}$, $C_L = 4.7 \text{ nF}$ $f = 300 \text{ to } 3400 \text{ Hz}$	ΔG_{RF}			± 0.5	dB
Gain change with current	$I_L = 15 \text{ to } 100 \text{ mA}$	ΔG_R			± 0.5	dB
Gain deviation	$T_{amb} = -10 \text{ to } +60^\circ\text{C}$ $I_L = 15 \text{ mA}$	ΔG_R			± 0.5	dB
Ear protection differential	$I_L \geq 15 \text{ mA}$ $V_{gen} = 11 \text{ V}_{rms}$	V_{ep}			2.2	V_{rms}
Output resistance	Each output against GND	R_o			10	Ω
Line loss compensation	$I_L = 100 \text{ mA}$ $R_{AGA} = 7.5 \text{ k}\Omega$	ΔG_{RI}	-5.0	-6.0	-7.0	dB
Output voltage Push pull	$I_L = 15 \text{ mA}$, $d \leq 2\%$ $Z_H = 68 \text{ nF}$ $Z_H = 450 \Omega$ $Z_H = 150 \Omega$		0.775 0.6 0.3			V_{rms}
Single ended						
Receiving noise psophometrically weighted	$Z_H = 68 \text{ nF}$ $G_R = 0 \text{ dB}$ $I_L > 15 \text{ mA}$	n_i		-83	-78.5	dBmp
Gain at low operating current	$I_L = 10 \text{ mA}$ $I_D = 1 \text{ mA}$ $I_M = 0 \text{ mA}$ $V_{gen} = 560 \text{ mV}$ $RC = 68 \text{ k}\Omega$	G_R	-1.5		+0.5	dB
Distortion at low operating current	$I_L = 10 \text{ mA}$, $I_D = 1 \text{ mA}$ $V_{gen} = 560 \text{ mV}$ $RC = 68 \text{ k}\Omega$	dr			5	%

Parameters	Test Conditions / Pins	Symbol	Min.	Typ.	Max.	Unit
Speaker amplifier see figure 7						
Minimum line current for operation	No ac signal	I_{Lmin}	10.5		15	mA
Gain from V_L to SAO	$I_L \geq 15$ mA $V_{gen} = 10$ mV	G_{SA}	27.5	29	30.5	dB
Output power	Load resistance $R_L = 50 \Omega$ $d < 5 \%$ $V_{gen} = 300$ mV _{rms} $I_L > 15$ mA $I_L = 20$ mA	PSA PSA	5	20		mW
Output noise	$I_L > 15$ mA (Input G_{SA} open)	n_{sa}			200	μ V
Gain deviation	$I_L = 15$ mA $T_{amb} = -10$ to $+60^\circ$ C	ΔG_{SA}			± 1	dB
Gain change with current	$I_L = 15$ to 100 mA $R_{AGA} = 7.5$ k Ω	ΔG_{SA}			± 1.5	dB
Resistor for turning off speaker amplifier	$I_L = 15$ to 100 mA	R_{GSA}	0.8	1.3	2	M Ω
Maximum off-state Output voltage	$I_L = 15$ mA $V_L = 0$ dBm Pin G_{SA} open	V_{SAO}			-50	dBm
Gain change with frequency	$I_L = 15$ mA $f = 300$ to 3400 Hz	ΔG_{SA}			± 1	dB
Attack time	20 dB overdrive	t_r		1		ms
Release time		t_f		300		ms
Distortion	$I_L = 15$ mA $V_{gen} = 300$ mV	d_{SAO}			5	%
DTMF - amplifier see figure 8						
Test conditions: $I_D = 2$ mA, $I_M = 0.3$ mA, $R_{AGA} = 7.5$ k Ω , mute active						
Adjustment range of DTMF gain	$I_L = 15$ mA Load = 600Ω	G_D	18	26	34	dB
DTMF amplification	$I_L = 15$ mA	G_D	24.5	26	27	dB
Gain deviation	$I_L = 15$ mA $T_{amb} = -10$ to 60° C	G_D			± 0.5	dB
Input resistance		R_i	20	25	30	k Ω
Distortion of DTMF signal	$I_L \geq 15$ mA $V_L = 0$ dBm	d			2	%
Gain deviation with current	$I_L = 15$ to 100 mA $R_{AGA} = 7.5$ k Ω	ΔG_D			± 0.5	dB

Parameters	Test Conditions / Pins	Symbol	Min.	Typ.	Max.	Unit
Supply voltage		see figure 4				
Test conditions: $V_{MIC} = 10 \text{ mV}$; $T_{amb} = -10 \text{ to } 60^\circ\text{C}$						
Output voltage	$I_L = 15 \text{ mA}$ $I_D = 2 \text{ mA}$ $RC = 68 \text{ k}\Omega$	V_D	2.9			V
	$I_L = 15 \text{ mA}$ $I_D = 2 \text{ mA}$ $RC = 130 \text{ k}\Omega$	V_D	3.1			V
	$I_L = 100 \text{ mA}$ $I_D = 0 \text{ mA}$ $T_{amb} = -10 \text{ to } +60^\circ\text{C}$	V_D			6.1	V
Supply voltage for an electret microphone	$I_M = 0.3 \text{ mA}$ $I_L \geq 15 \text{ mA}$ $RC = 130 \text{ k}\Omega$	V_M	1.45		3.3	V
Squelch		see figure 9				
Attenuation of transmit gain	$I_L \geq 15 \text{ mA}$	ΔG_S	8	10	12	dB
Attenuation of speaker amplifier	$I_L \geq 15 \text{ mA}$ $R_{GSA} = 18 \text{ to } 560 \text{ k}\Omega$	ΔG_{SA}	7.5	10	12.5	dB
Switching level of squelch	$I_L \geq 15 \text{ mA}$ $RSQ = 100 \text{ k}\Omega$	V_{mico}	6.5		10	mV
Squelch disable	$I_L \geq 15 \text{ mA}$	RSQ	0.5	1	2	$M\Omega$
MUTE input		see figure 10				
MUTE input current	MUTE active $I_L > 15 \text{ mA}$ $V_{MUTE} = V_D$	I_{MUTE}		20	30	μA
MUTE input voltage	Mute inactive $I_L > 15 \text{ mA}$	V_{MUTE}			0,3	V
	Mute active $I_L > 15 \text{ mA}$	V_{MUTE}	1.5		0,3	V
PD input		see figure 10				
PD input current	PD active $I_L > 15 \text{ mA}$ $V_{PD} = V_D$	I_{PD}		20	50	μA
Input voltage	PD = active	V_{PD}	2			V
	PD = inactive	V_{PD}			0.3	V
Current consumption	$V_D = V_{PD} = 4.5 \text{ V}$ PD = active $I_L = 15 \text{ mA}$	I_{DPD}		-40	-100	μA
Voltage drop at V_L	$I_L = 15 \text{ mA}$ PD = active	V_L		1.5		V
	$I_L = 100 \text{ mA}$ PD = active	V_L		1.7		V

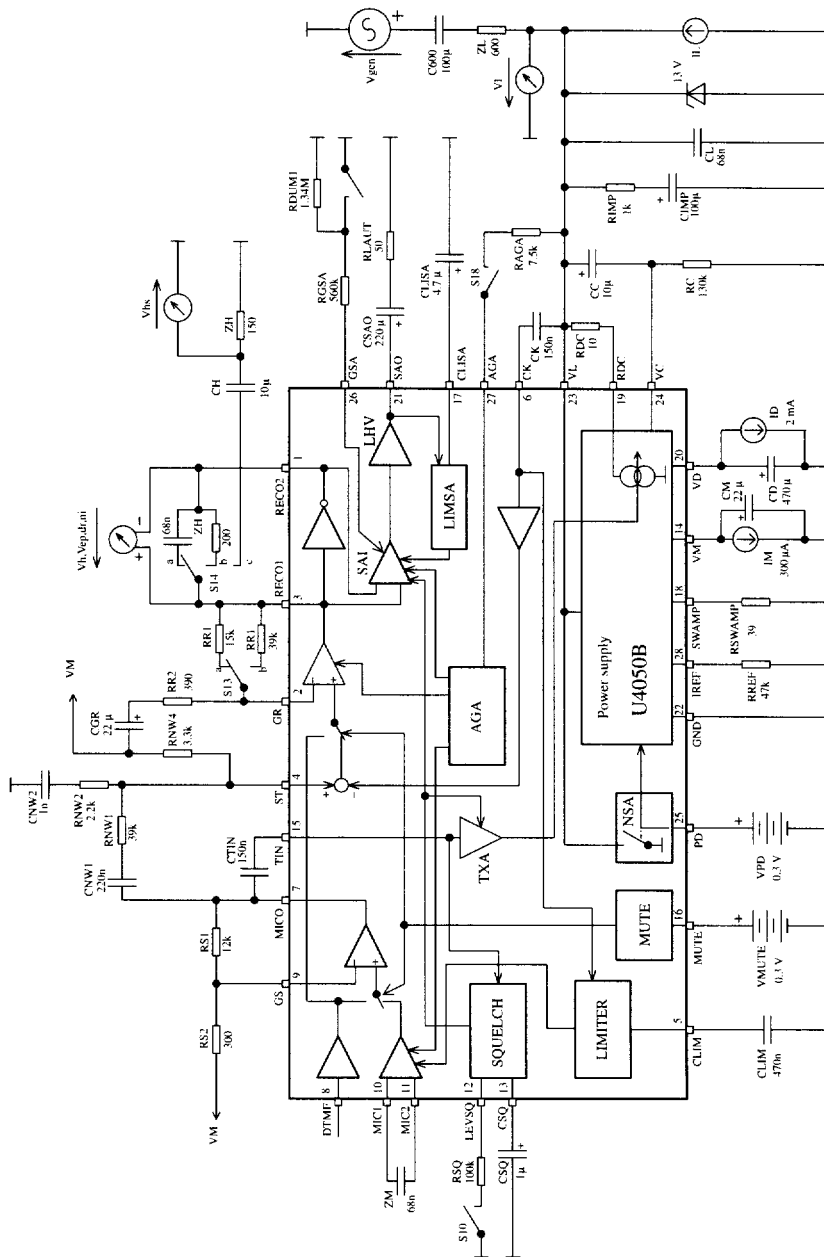

Figure 6. Test circuit for receiving amplifier

93 7817 e

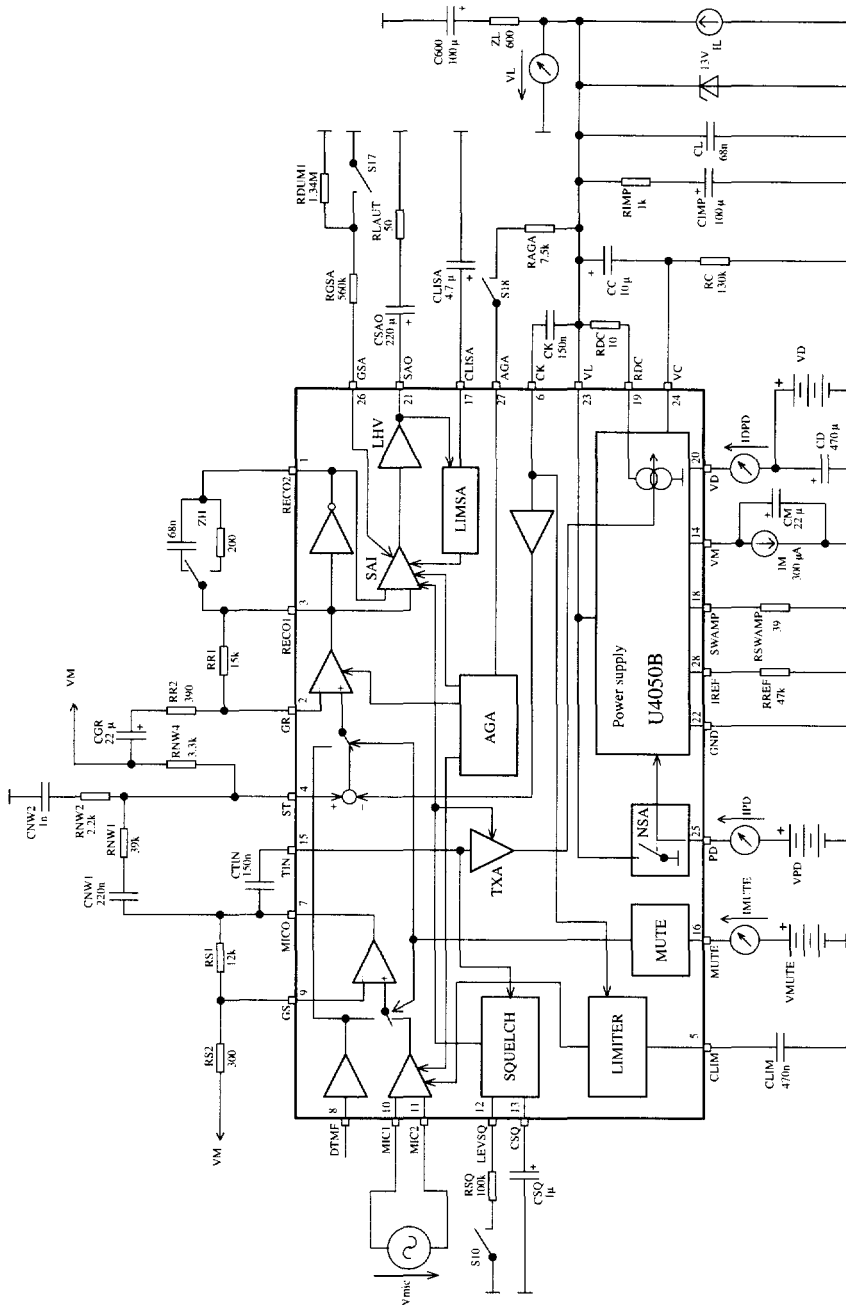

Figure 10. Test circuit for MUTE and PD test

93 7823 e

Typical Curves

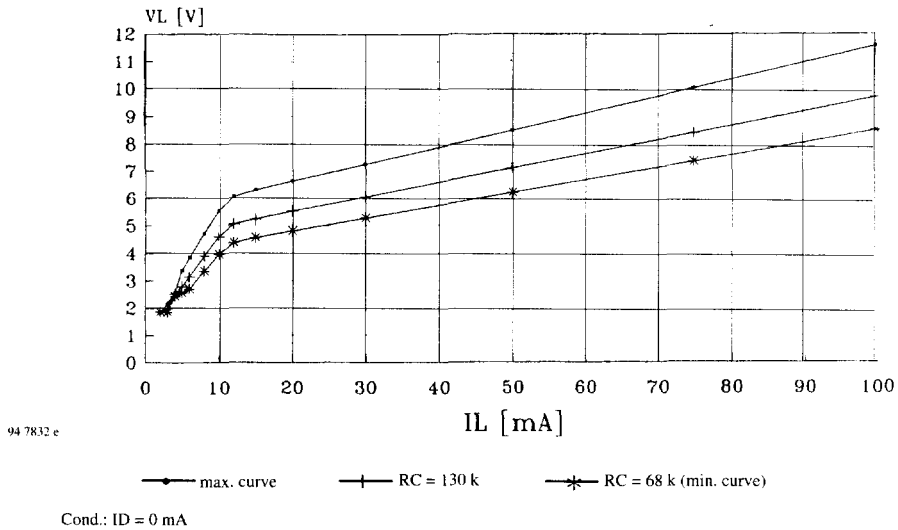

Figure 12. DC characteristics

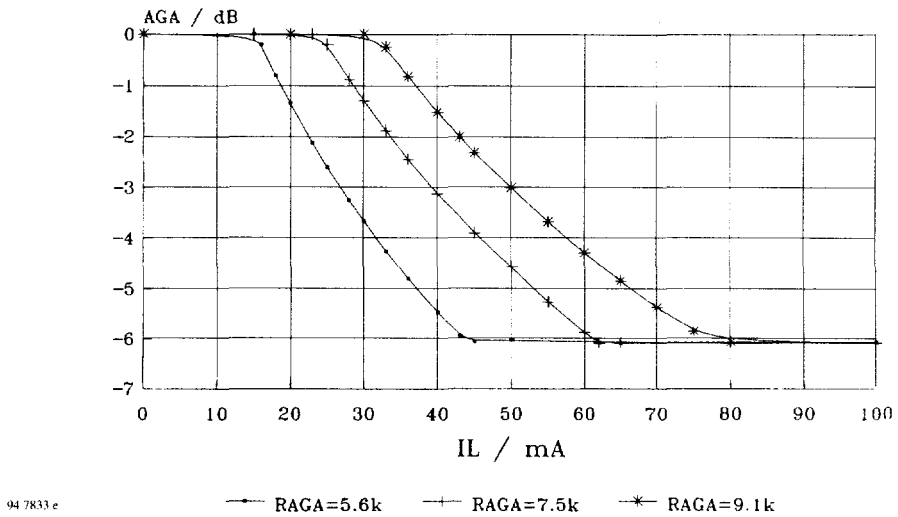
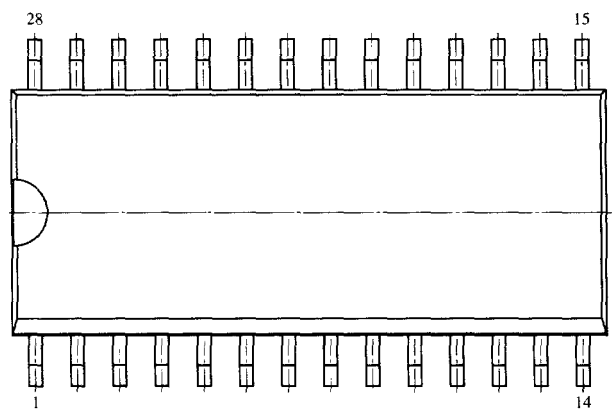
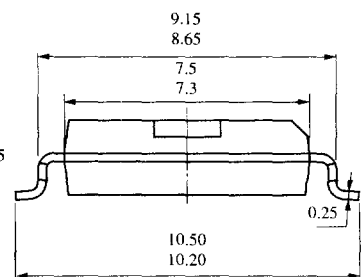
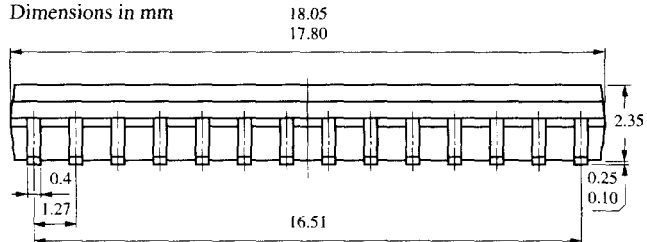

Figure 13. AGA characteristics

Package Information

Package SO28

Dimensions in mm



technical drawings
according to DIN
specifications

13033

