

Datasheet Errata

Base datasheet:

GS816019/33/37AT, Rev.1.00, 3/2002

Product(s) covered in this supplement:

GS816019/33/37AT-300/275/250/225/200

Product specification(s) addressed by this supplement:

Pin 14

Note: The specifications cited in the base datasheet for the products addressed by this errata remain in force except where superseded by the information in this errata.

Datasheet Errata

GS816019A 100-Pin TQFP Pinout

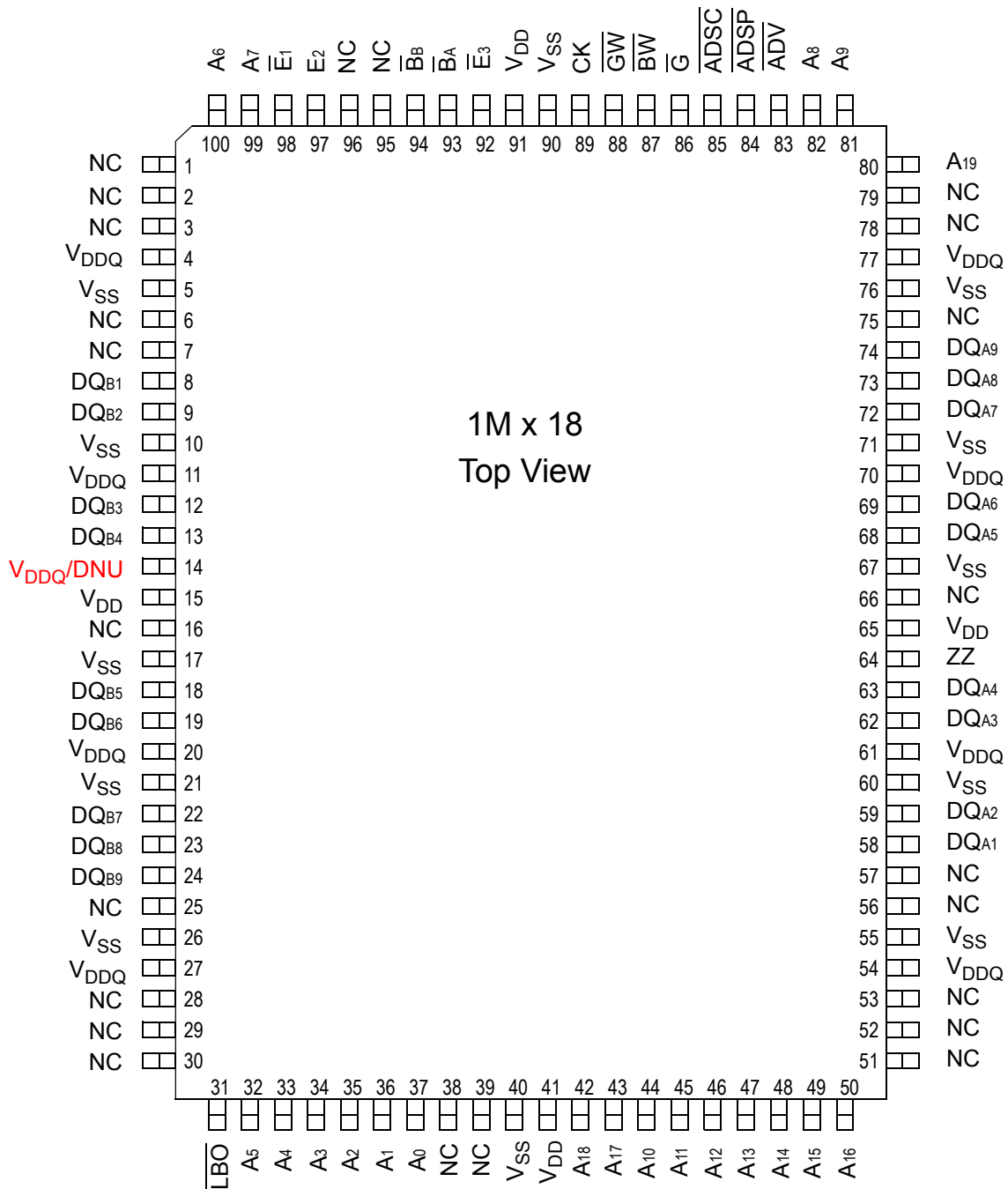

Datasheet Errata

GS816033A 100-Pin TQFP Pinout

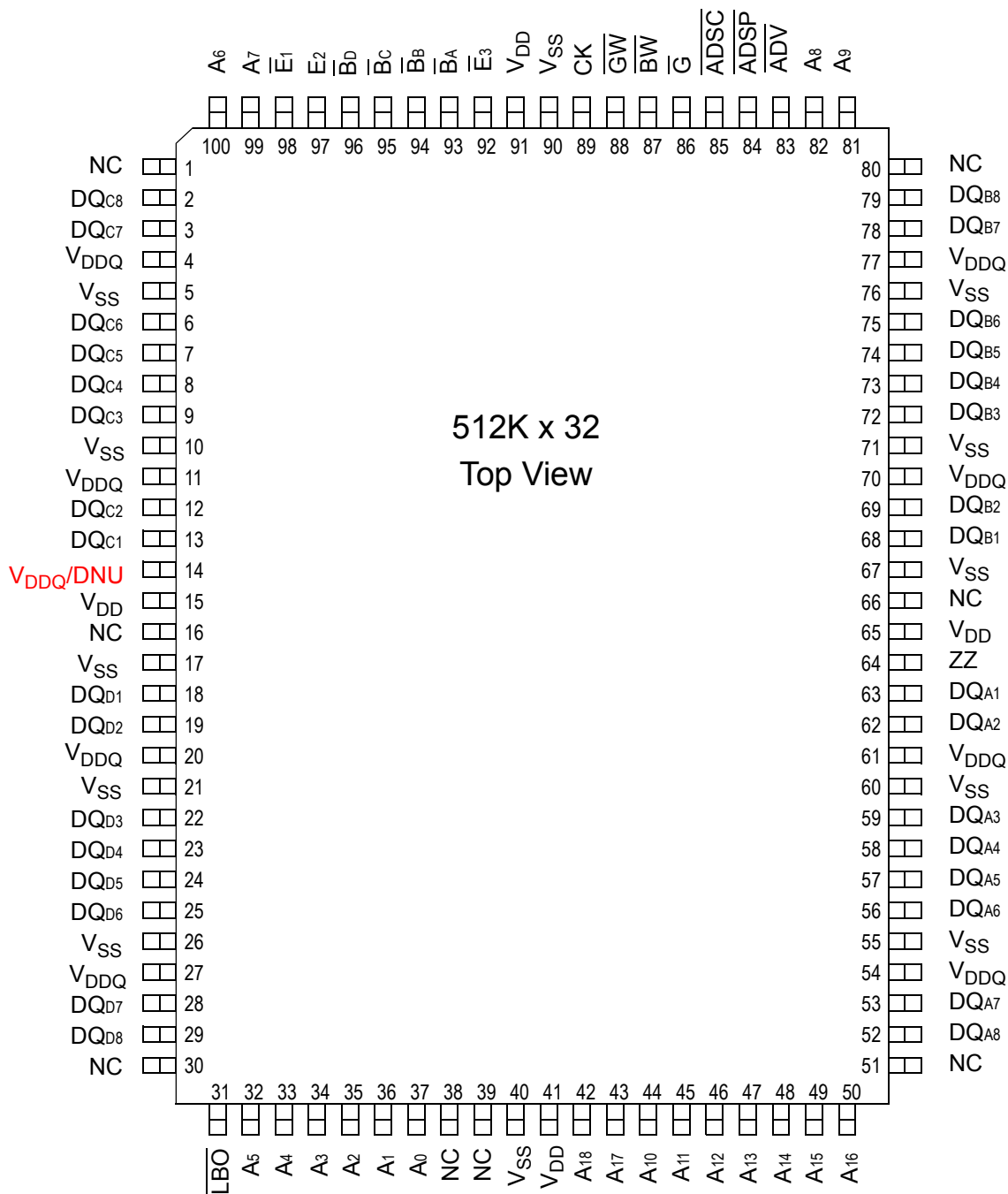

Datasheet Errata

GS816037A 100-Pin TQFP Pinout

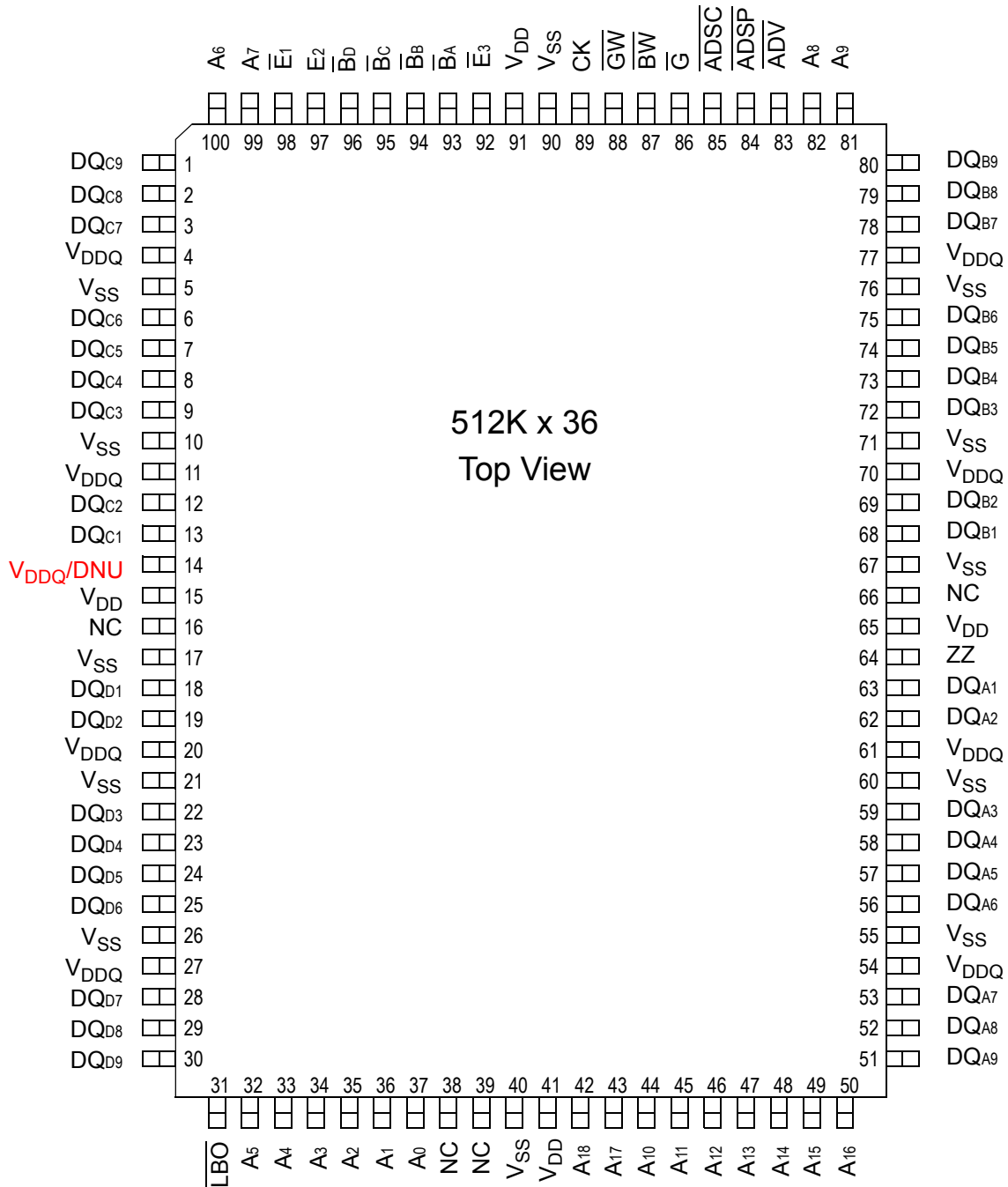

Datasheet Errata

TQFP Pin Description

Pin Location	Symbol	Type	Description
37, 36	A ₀ , A ₁	I	Address field LSBs and Address Counter preset Inputs
35, 34, 33, 32, 100, 99, 82, 81, 44, 45, 46, 47, 48, 49, 50, 43, 42	A ₂ –A ₁₈	I	Address Inputs
80	A ₁₉	I	Address Inputs (x18 versions)
63, 62, 59, 58, 57, 56, 53, 52 68, 69, 72, 73, 74, 75, 78, 79 13, 12, 9, 8, 7, 6, 3, 2 18, 19, 22, 23, 24, 25, 28, 29	DQA ₁ –DQA ₈ DQB ₁ –DQB ₈ DQC ₁ –DQC ₈ DQD ₁ –DQD ₈	I/O	Data Input and Output pins (x32, x36 Version)
51, 80, 1, 30	DQA ₉ , DQB ₉ , DQC ₉ , DQD ₉	I/O	Data Input and Output pins (x36 Version)
51, 80, 1, 30	NC		No Connect (x32 Version)
58, 59, 62, 63, 68, 69, 72, 73, 74 8, 9, 12, 13, 18, 19, 22, 23, 24	DQA ₁ –DQA ₉ DQB ₁ –DQB ₉	I/O	Data Input and Output pins (x18 Version)
51, 52, 53, 56, 57 75, 78, 79, 95, 96, 1, 2, 3, 6, 7, 25, 28, 29, 30	NC	—	No Connect (x18 Version)
87	\overline{BW}	I	Byte Write—Writes all enabled bytes; active low
93, 94	\overline{BA} , \overline{BB}	I	Byte Write Enable for DQA, DQB Data I/Os; active low
95, 96	\overline{BC} , \overline{BD}	I	Byte Write Enable for DQC, DQD Data I/Os; active low (x32, x36 Version)
89	CK	I	Clock Input Signal; active high
88	\overline{GW}	I	Global Write Enable—Writes all bytes; active low
98, 92	$\overline{E1}$, $\overline{E3}$	I	Chip Enable; active low
97	E ₂	I	Chip Enable; active high
86	\overline{G}	I	Output Enable; active low
83	\overline{ADV}	I	Burst address counter advance enable; active low
84, 85	\overline{ADSP} , \overline{ADSC}	I	Address Strobe (Processor, Cache Controller); active low
64	ZZ	I	Sleep Mode control; active high
31	\overline{LBO}	I	Linear Burst Order mode; active low
15, 41, 65, 91	V _{DD}	I	Core power supply
5,10,17, 21, 26, 40, 55, 60, 67, 71, 76, 90	V _{SS}	I	I/O and Core Ground
4, 11, 20, 27, 54, 61, 70, 77	V _{DDQ}	I	Output driver power supply
16, 38, 39, 66	NC	—	No Connect
14	V _{DDQ} /DNU	—	V _{DD} or V _{DDQ} (must be tied high) or Do Not Use (must be left floating)

100-Pin TQFP	1M x 18, 512K x 32, 512K x 36	300 MHz–200 MHz
Commercial Temp	18Mb Sync Burst SRAMs	1.8 V or 2.5 V V_{DD}
Industrial Temp		1.8 V or 2.5 V I/O

Features

- 1.8 V or 2.5 V +10%/–10% core power supply
- 1.8 V or 2.5 V I/O supply
- \overline{LBO} pin for Linear or Interleaved Burst mode
- Internal input resistors on mode pins allow floating mode pins
- Default to Interleaved Pipeline mode
- Byte Write (\overline{BW}) and/or Global Write (\overline{GW}) operation
- Internal self-timed write cycle
- Automatic power-down for portable applications
- JEDEC-standard 100-lead TQFP package

		-300	-275	-250	-225	-200	Unit
Pipeline	t_{kQ}	1.7	1.9	2.0	2.2	2.5	ns
	t_{Cycle}	3.3	3.6	4.0	4.4	5.0	ns
2.5 V	Curr (x18)	320	300	275	250	230	mA
	Curr (x32/x36)	375	345	320	295	265	mA
1.8 V	Curr (x18)	320	300	275	250	225	mA
	Curr (x32/x36)	370	340	315	285	260	mA

Byte Write and Global Write

Byte write operation is performed by using Byte Write enable (\overline{BW}) input combined with one or more individual byte write signals (\overline{Bx}). In addition, Global Write (\overline{GW}) is available for writing all bytes at one time, regardless of the Byte Write control inputs.

Sleep Mode

Low power (Sleep mode) is attained through the assertion (High) of the ZZ signal, or by stopping the clock (CK). Memory data is retained during Sleep mode.

Core and Interface Voltages

The GS816019/33/37AT operates on a 1.8 V or 2.5 V power supply. All inputs are 2.5 V and 1.8 V compatible. Separate output power (V_{DDQ}) pins are used to decouple output noise from the internal circuits and are 2.5 V and 1.8 V compatible.

Functional Description

Applications

The GS816019/33/37AT is a 18,874,368-bit (16,777,216-bit for x32 version) high performance synchronous SRAM with a 2-bit burst address counter. Although of a type originally developed for Level 2 Cache applications supporting high performance CPUs, the device now finds application in synchronous SRAM applications, ranging from DSP main store to networking chip set support.

Controls

Addresses, data I/Os, chip enables ($\overline{E1}$, $E2$, $\overline{E3}$), address burst control inputs (\overline{ADSP} , \overline{ADSC} , \overline{ADV}), and write control inputs (\overline{Bx} , \overline{BW} , \overline{GW}) are synchronous and are controlled by a positive-edge-triggered clock input (CK). Output enable (\overline{G}) and power down control (ZZ) are asynchronous inputs. Burst cycles can be initiated with either \overline{ADSP} or \overline{ADSC} inputs. In Burst mode, subsequent burst addresses are generated internally and are controlled by \overline{ADV} . The burst address counter may be configured to count in either linear or interleave order with the Linear Burst Order (\overline{LBO}) input. The Burst function need not be used. New addresses can be loaded on every cycle with no degradation of chip performance.

GS816019A 100-Pin TQFP Pinout

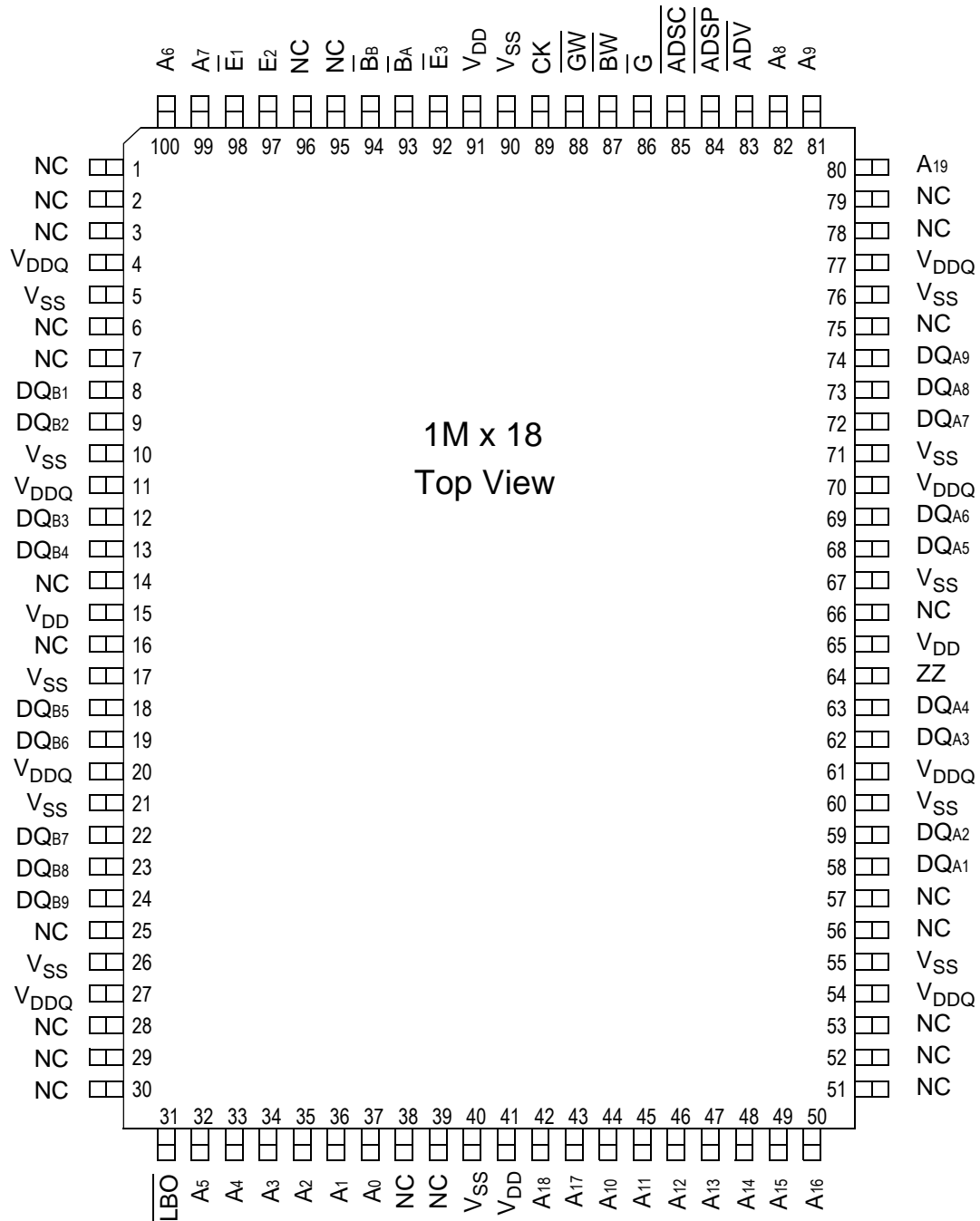

GS816033A 100-Pin TQFP Pinout

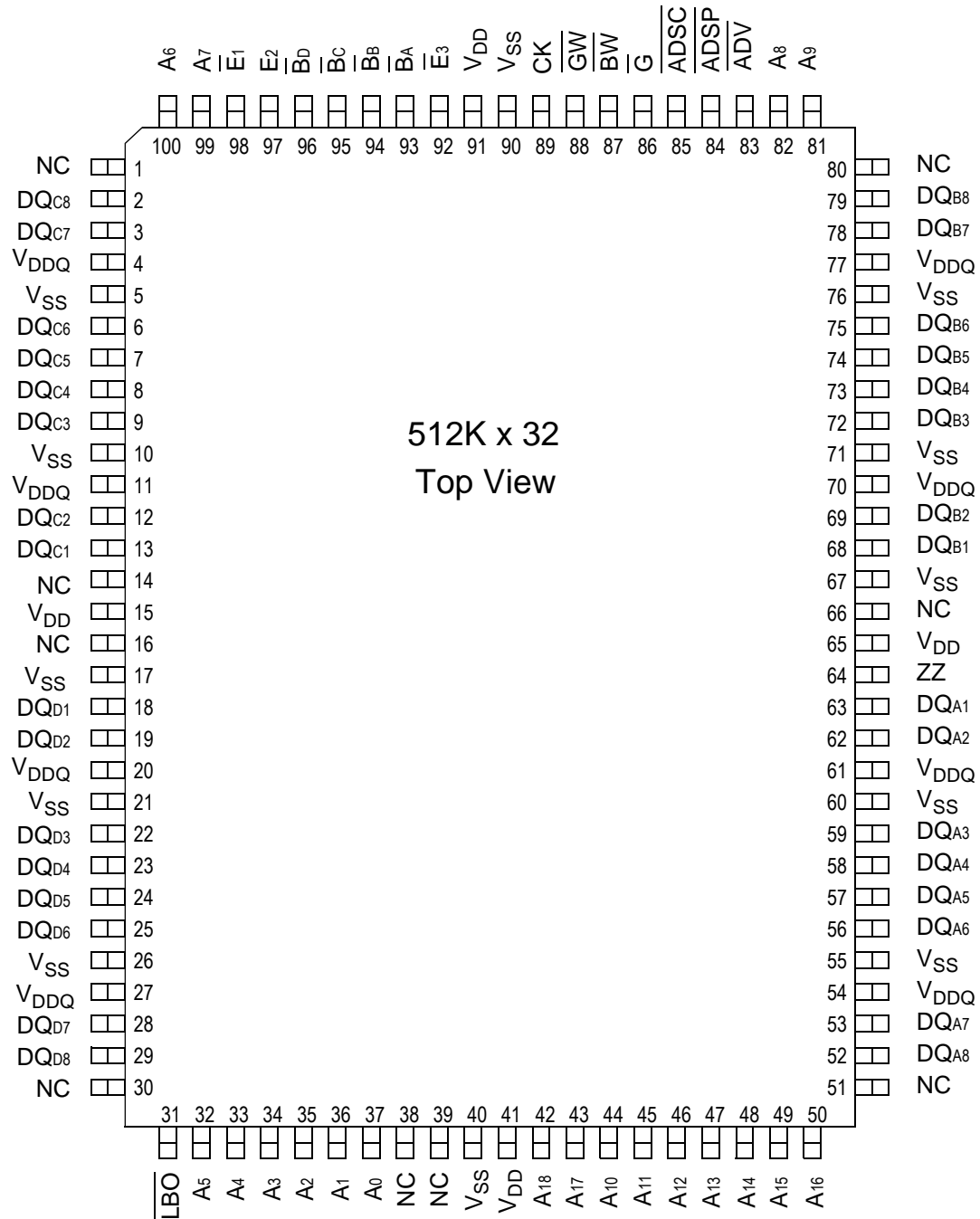

GS816037A 100-Pin TQFP Pinout

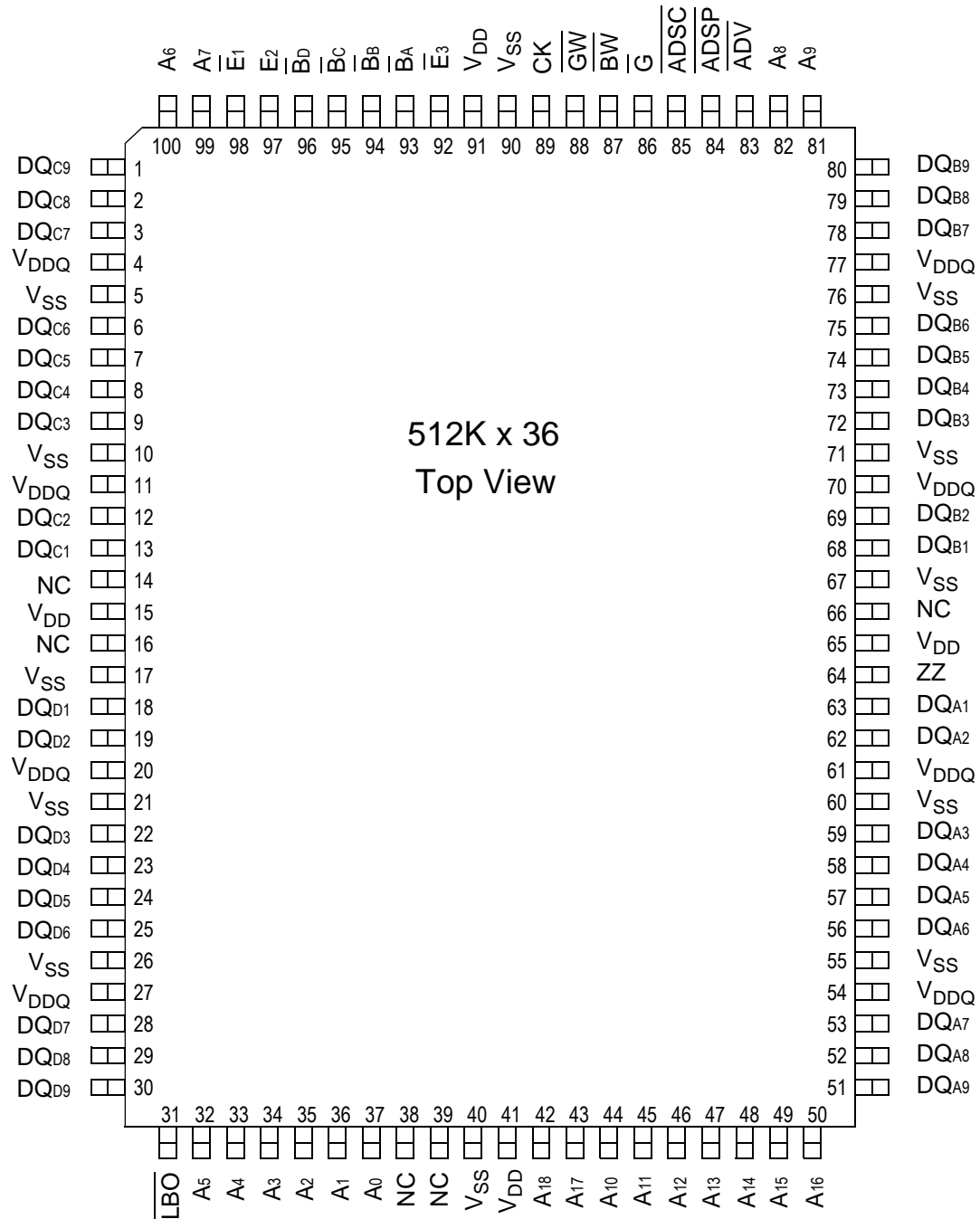

TQFP Pin Description

Pin Location	Symbol	Type	Description
37, 36	A ₀ , A ₁	I	Address field LSBs and Address Counter preset Inputs
35, 34, 33, 32, 100, 99, 82, 81, 44, 45, 46, 47, 48, 49, 50, 43, 42	A ₂ –A ₁₈	I	Address Inputs
80	A ₁₉	I	Address Inputs (x18 versions)
63, 62, 59, 58, 57, 56, 53, 52 68, 69, 72, 73, 74, 75, 78, 79 13, 12, 9, 8, 7, 6, 3, 2 18, 19, 22, 23, 24, 25, 28, 29	DQA ₁ –DQA ₈ DQB ₁ –DQB ₈ DQC ₁ –DQC ₈ DQD ₁ –DQD ₈	I/O	Data Input and Output pins (x32, x36 Version)
51, 80, 1, 30	DQA ₉ , DQB ₉ , DQC ₉ , DQD ₉	I/O	Data Input and Output pins (x36 Version)
51, 80, 1, 30	NC		No Connect (x32 Version)
58, 59, 62, 63, 68, 69, 72, 73, 74 8, 9, 12, 13, 18, 19, 22, 23, 24	DQA ₁ –DQA ₉ DQB ₁ –DQB ₉	I/O	Data Input and Output pins (x18 Version)
51, 52, 53, 56, 57 75, 78, 79, 95, 96, 1, 2, 3, 6, 7, 25, 28, 29, 30	NC	—	No Connect (x18 Version)
87	\overline{BW}	I	Byte Write—Writes all enabled bytes; active low
93, 94	B _A , B _B	I	Byte Write Enable for DQA, DQB Data I/Os; active low
95, 96	$\overline{B_C}$, $\overline{B_D}$	I	Byte Write Enable for DQC, DQD Data I/Os; active low (x32, x36 Version)
89	CK	I	Clock Input Signal; active high
88	\overline{GW}	I	Global Write Enable—Writes all bytes; active low
98, 92	E ₁ , E ₃	I	Chip Enable; active low
97	E ₂	I	Chip Enable; active high
86	\overline{G}	I	Output Enable; active low
83	\overline{ADV}	I	Burst address counter advance enable; active low
84, 85	\overline{ADSP} , \overline{ADSC}	I	Address Strobe (Processor, Cache Controller); active low
64	\overline{ZZ}	I	Sleep Mode control; active high
31	\overline{LBO}	I	Linear Burst Order mode; active low
15, 41, 65, 91	V _{DD}	I	Core power supply
5,10,17, 21, 26, 40, 55, 60, 67, 71, 76, 90	V _{SS}	I	I/O and Core Ground
4, 11, 20, 27, 54, 61, 70, 77	V _{DDQ}	I	Output driver power supply
14, 16, 38, 39, 66	NC	—	No Connect

GS816019/33/37A Block Diagram

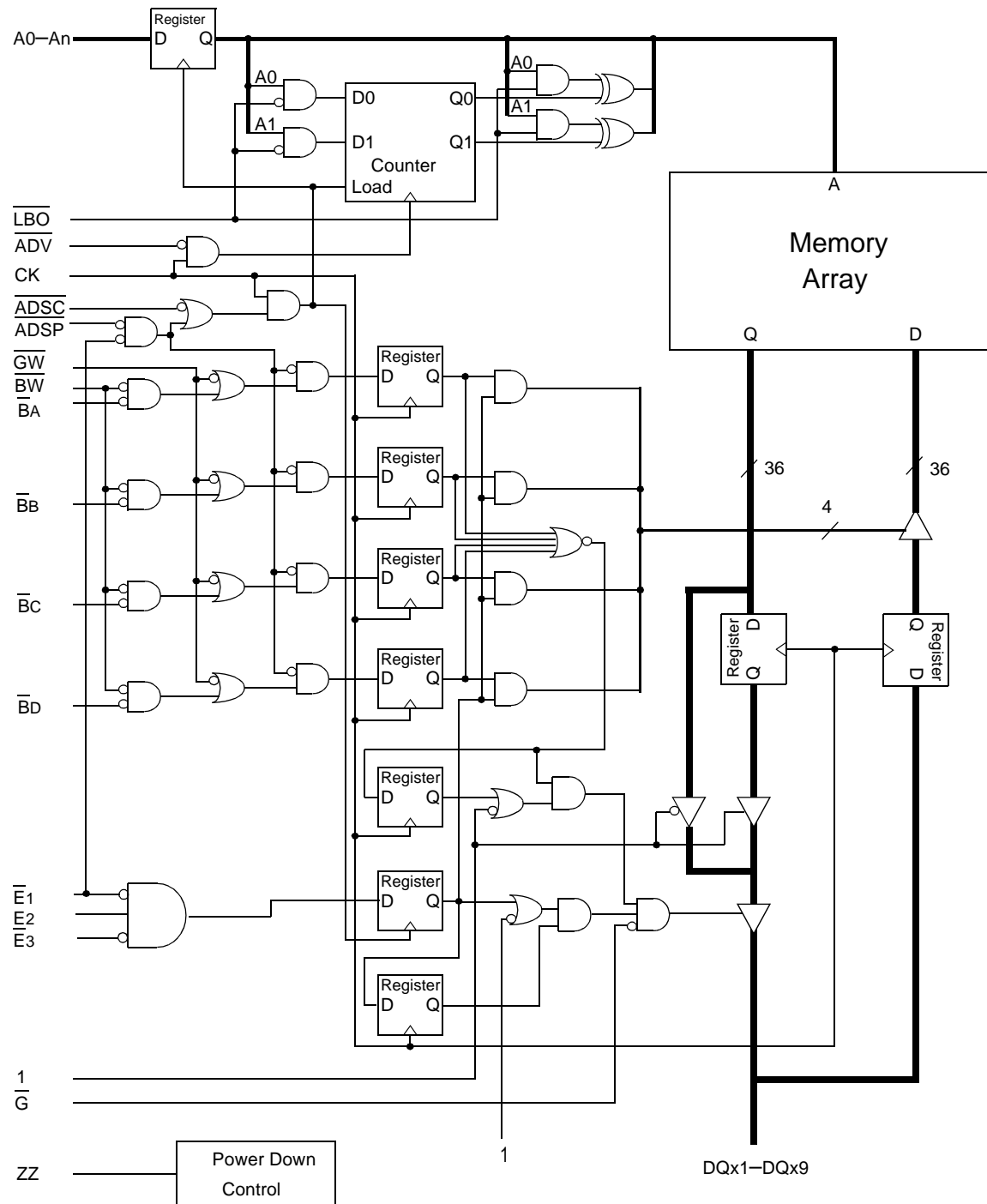

Note: Only x36 version shown for simplicity.

Mode Pin Functions

Mode Name	Pin Name	State	Function
Burst Order Control	$\overline{\text{LBO}}$	L	Linear Burst
		H	Interleaved Burst
Power Down Control	ZZ	L or NC	Active
		H	Standby, $I_{DD} = I_{SB}$

Note:

There is a pull-down device on the ZZ pin, so this input pin can be unconnected and the chip will operate in the default states as specified in the above tables.

Burst Counter Sequences

Linear Burst Sequence

	A[1:0]	A[1:0]	A[1:0]	A[1:0]
1st address	00	01	10	11
2nd address	01	10	11	00
3rd address	10	11	00	01
4th address	11	00	01	10

Note: The burst counter wraps to initial state on the 5th clock.

Interleaved Burst Sequence

	A[1:0]	A[1:0]	A[1:0]	A[1:0]
1st address	00	01	10	11
2nd address	01	00	11	10
3rd address	10	11	00	01
4th address	11	10	01	00

Note: The burst counter wraps to initial state on the 5th clock.

BPR 1999.05.18

Byte Write Truth Table

Function	$\overline{\text{GW}}$	$\overline{\text{BW}}$	$\overline{\text{BA}}$	$\overline{\text{BB}}$	$\overline{\text{BC}}$	$\overline{\text{BD}}$	Notes
Read	H	H	X	X	X	X	1
Read	H	L	H	H	H	H	1
Write byte a	H	L	L	H	H	H	2, 3
Write byte b	H	L	H	L	H	H	2, 3
Write byte c	H	L	H	H	L	H	2, 3, 4
Write byte d	H	L	H	H	H	L	2, 3, 4
Write all bytes	H	L	L	L	L	L	2, 3, 4
Write all bytes	L	X	X	X	X	X	

Notes:

- All byte outputs are active in read cycles regardless of the state of Byte Write Enable inputs.
- Byte Write Enable inputs BA, BB, BC and/or BD may be used in any combination with BW to write single or multiple bytes.
- All byte I/Os remain High-Z during all write operations regardless of the state of Byte Write Enable inputs.
- Bytes "c" and "d" are only available on the x32 and x36 versions.

Synchronous Truth Table

Operation	Address Used	State Diagram Key ⁵	\bar{E}_1	E^2	\overline{ADSP}	\overline{ADSC}	\overline{ADV}	\bar{W}^3	DQ ⁴
Deselect Cycle, Power Down	None	X	H	X	X	L	X	X	High-Z
Deselect Cycle, Power Down	None	X	L	F	L	X	X	X	High-Z
Deselect Cycle, Power Down	None	X	L	F	H	L	X	X	High-Z
Read Cycle, Begin Burst	External	R	L	T	L	X	X	X	Q
Read Cycle, Begin Burst	External	R	L	T	H	L	X	F	Q
Write Cycle, Begin Burst	External	W	L	T	H	L	X	T	D
<i>Read Cycle, Continue Burst</i>	<i>Next</i>	<i>CR</i>	<i>X</i>	<i>X</i>	<i>H</i>	<i>H</i>	<i>L</i>	<i>F</i>	<i>Q</i>
Read Cycle, Continue Burst	Next	CR	H	X	X	H	L	F	Q
<i>Write Cycle, Continue Burst</i>	<i>Next</i>	<i>CW</i>	<i>X</i>	<i>X</i>	<i>H</i>	<i>H</i>	<i>L</i>	<i>T</i>	<i>D</i>
Write Cycle, Continue Burst	Next	CW	H	X	X	H	L	T	D
Read Cycle, Suspend Burst	Current		X	X	H	H	H	F	Q
Read Cycle, Suspend Burst	Current		H	X	X	H	H	F	Q
Write Cycle, Suspend Burst	Current		X	X	H	H	H	T	D
Write Cycle, Suspend Burst	Current		H	X	X	H	H	T	D

Notes:

- X = Don't Care, H = High, L = Low
- E = T (True) if $E_2 = 1$ and $E_3 = 0$; E = F (False) if $E_2 = 0$ or $E_3 = 1$
- $\bar{W} = T$ (True) and F (False) is defined in the Byte Write Truth Table preceding.
- \bar{G} is an asynchronous input. \bar{G} can be driven high at any time to disable active output drivers. \bar{G} low can only enable active drivers (shown as "Q" in the Truth Table above).
- All input combinations shown above are tested and supported. Input combinations shown in gray boxes need not be used to accomplish basic synchronous or synchronous burst operations and may be avoided for simplicity.
- Tying \overline{ADSP} high and \overline{ADSC} low allows simple non-burst synchronous operations. See **BOLD** items above.
- Tying \overline{ADSP} high and \overline{ADV} low while using \overline{ADSC} to load new addresses allows simple burst operations. See *ITALIC* items above.

Simplified State Diagram

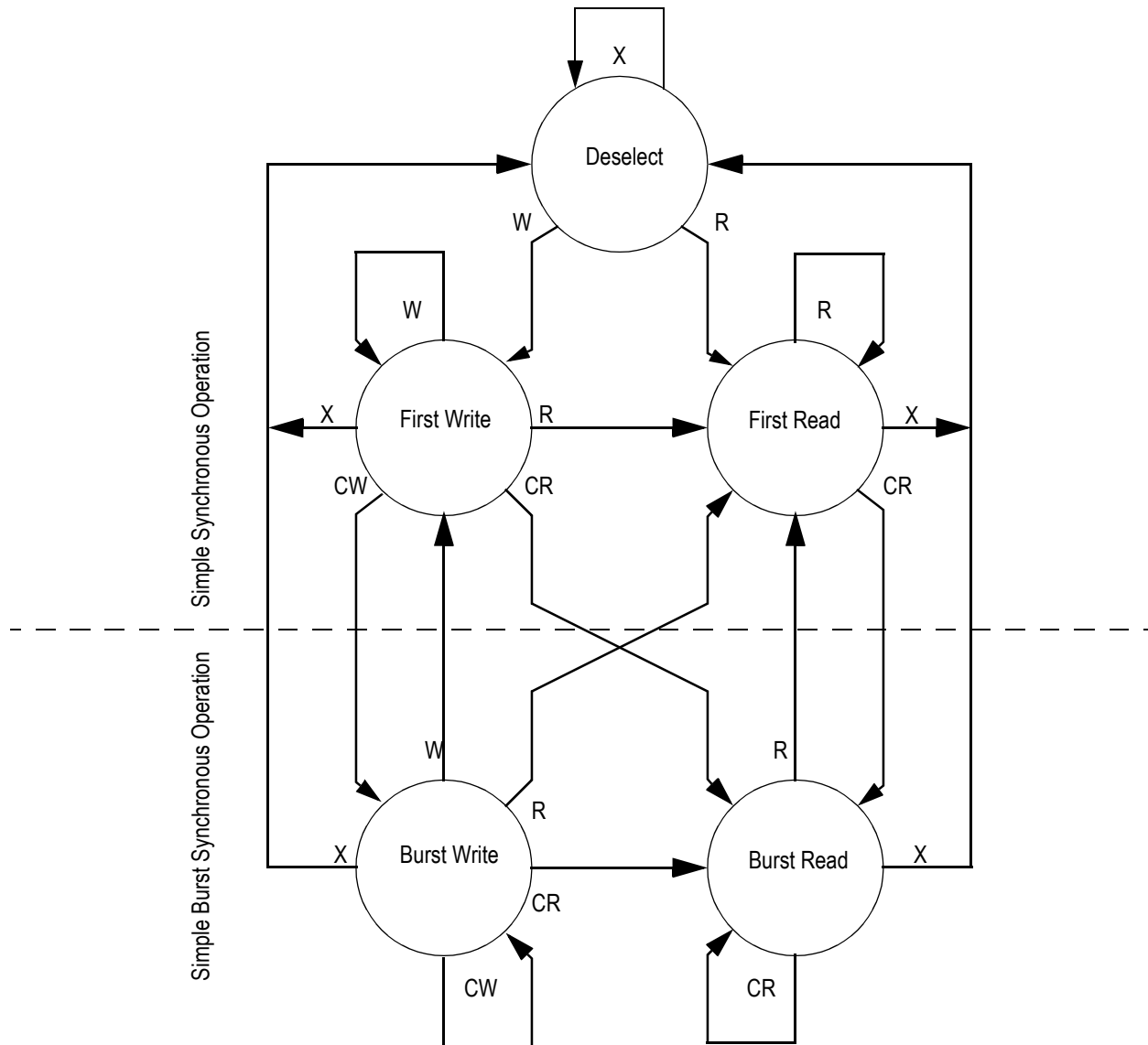

Notes:

1. The diagram shows only supported (tested) synchronous state transitions. The diagram presumes \overline{G} is tied low.
2. The upper portion of the diagram assumes active use of only the Enable (E1, E2, and E3) and Write (BA, BB, BC, BD, BW, and GW) control inputs, and that ADSP is tied high and ADSC is tied low.
3. The upper and lower portions of the diagram together assume active use of only the Enable, Write, and \overline{ADSC} control inputs, and assumes ADSP is tied high and ADV is tied low.

Simplified State Diagram with \overline{G}

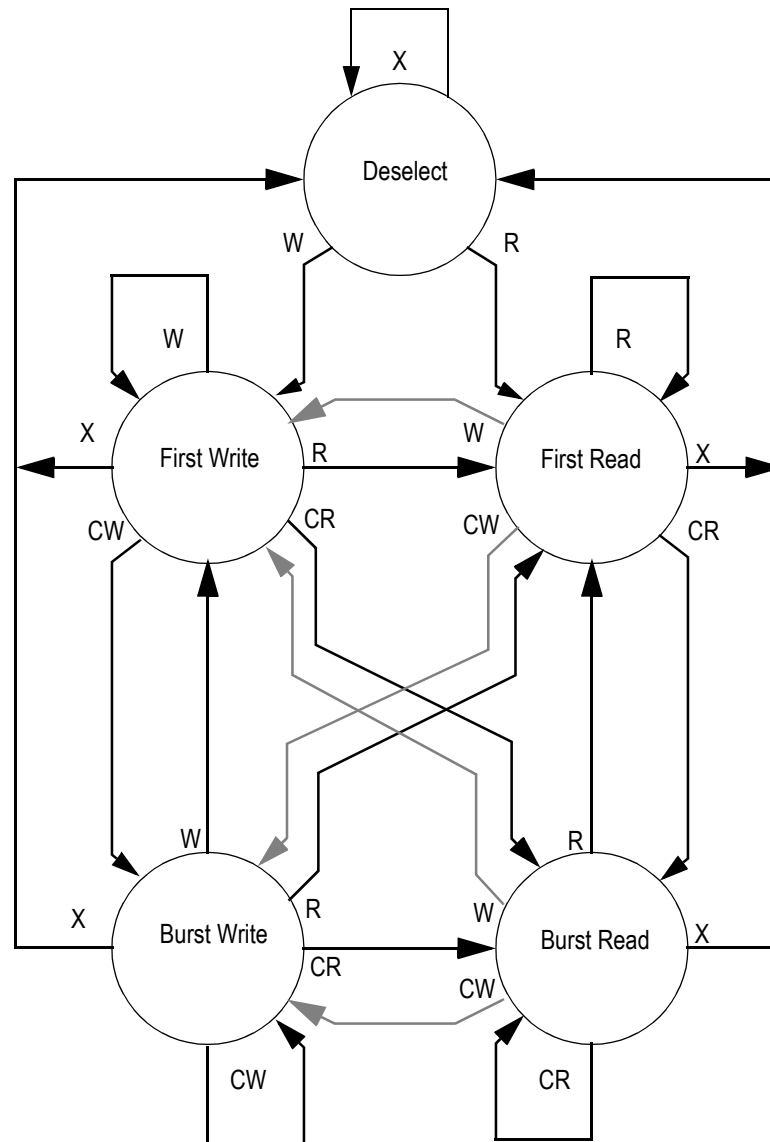

Notes:

1. The diagram shows supported (tested) synchronous state transitions plus supported transitions that depend upon the use of \overline{G} .
2. Use of "Dummy Reads" (Read Cycles with \overline{G} High) may be used to make the transition from Read cycles to Write cycles without passing through a Deselect cycle. Dummy Read cycles increment the address counter just like normal read cycles.
3. Transitions shown in gray tone assume \overline{G} has been pulsed high long enough to turn the RAM's drivers off and for incoming data to meet Data Input Set Up Time.

Absolute Maximum Ratings

(All voltages reference to V_{SS})

Symbol	Description	Value	Unit
V_{DD}	Voltage on V_{DD} Pins	-0.5 to 3.6	V
V_{DDQ}	Voltage in V_{DDQ} Pins	-0.5 to 3.6	V
V_{CK}	Voltage on Clock Input Pin	-0.5 to 3.6	V
$V_{I/O}$	Voltage on I/O Pins	-0.5 to $V_{DDQ} + 0.5$ (≤ 3.6 V max.)	V
V_{IN}	Voltage on Other Input Pins	-0.5 to $V_{DD} + 0.5$ (≤ 3.6 V max.)	V
I_{IN}	Input Current on Any Pin	+/-20	mA
I_{OUT}	Output Current on Any I/O Pin	+/-20	mA
P_D	Package Power Dissipation	1.5	W
T_{STG}	Storage Temperature	-55 to 125	°C
T_{BIAS}	Temperature Under Bias	-55 to 125	°C

Note:

Permanent damage to the device may occur if the Absolute Maximum Ratings are exceeded. Operation should be restricted to Recommended Operating Conditions. Exposure to conditions exceeding the Absolute Maximum Ratings, for an extended period of time, may affect reliability of this component.

Power Supply Voltage Ranges

Parameter	Symbol	Min.	Typ.	Max.	Unit	Notes
2.5 V Supply Voltage	V_{DD2}	2.3	2.5	2.7	V	
1.8 V Supply Voltage	V_{DD1}	1.6	1.8	2.0	V	
2.5 V V_{DDQ} I/O Supply Voltage	V_{DDQ2}	2.3	2.5	2.7	V	
1.8 V V_{DDQ} I/O Supply Voltage	V_{DDQ1}	1.6	1.8	2.0	V	

Notes:

- The part numbers of Industrial Temperature Range versions end the character "I". Unless otherwise noted, all performance specifications quoted are evaluated for worst case in the temperature range marked on the device.
- Input Under/overshoot voltage must be $-2\text{ V} > V_i < V_{DDn} + 2\text{ V}$ not to exceed 3.6 V maximum, with a pulse width not to exceed 20% tKC.

V_{DDQ2} Range Logic Levels

Parameter	Symbol	Min.	Typ.	Max.	Unit	Notes
V_{DD} Input High Voltage	V_{IH}	$0.6 \cdot V_{DD}$	—	$V_{DD} + 0.3$	V	1
V_{DD} Input Low Voltage	V_{IL}	-0.3	—	$0.3 \cdot V_{DD}$	V	1
V_{DDQ} I/O Input High Voltage	V_{IHQ}	$0.6 \cdot V_{DD}$	—	$V_{DDQ} + 0.3$	V	1,3
V_{DDQ} I/O Input Low Voltage	V_{ILQ}	-0.3	—	$0.3 \cdot V_{DD}$	V	1,3

Notes:

- The part numbers of Industrial Temperature Range versions end the character "I". Unless otherwise noted, all performance specifications quoted are evaluated for worst case in the temperature range marked on the device.
- Input Under/overshoot voltage must be $-2\text{ V} > V_i < V_{DDn} + 2\text{ V}$ not to exceed 3.6 V maximum, with a pulse width not to exceed 20% tKC.
- V_{IHQ} (max) is voltage on V_{DDQ} pins plus 0.3 V.

V_{DDQ1} Range Logic Levels

Parameter	Symbol	Min.	Typ.	Max.	Unit	Notes
V_{DD} Input High Voltage	V_{IH}	$0.6 \cdot V_{DD}$	—	$V_{DD} + 0.3$	V	1
V_{DD} Input Low Voltage	V_{IL}	-0.3	—	$0.3 \cdot V_{DD}$	V	1
V_{DDQ} I/O Input High Voltage	V_{IHQ}	$0.6 \cdot V_{DD}$	—	$V_{DDQ} + 0.3$	V	1,3
V_{DDQ} I/O Input Low Voltage	V_{ILQ}	-0.3	—	$0.3 \cdot V_{DD}$	V	1,3

Notes:

- The part numbers of Industrial Temperature Range versions end the character "I". Unless otherwise noted, all performance specifications quoted are evaluated for worst case in the temperature range marked on the device.
- Input Under/overshoot voltage must be $-2\text{ V} > V_i < V_{DDn} + 2\text{ V}$ not to exceed 3.6 V maximum, with a pulse width not to exceed 20% tKC.
- V_{IHQ} (max) is voltage on V_{DDQ} pins plus 0.3 V.

Recommended Operating Temperatures

Parameter	Symbol	Min.	Typ.	Max.	Unit	Notes
Ambient Temperature (Commercial Range Versions)	T_A	0	25	70	°C	2
Ambient Temperature (Industrial Range Versions)	T_A	-40	25	85	°C	2

Note:

- The part numbers of Industrial Temperature Range versions end the character "I". Unless otherwise noted, all performance specifications quoted are evaluated for worst case in the temperature range marked on the device.
- Input Under/overshoot voltage must be $-2\text{ V} > V_i < V_{DDn} + 2\text{ V}$ not to exceed 3.6 V maximum, with a pulse width not to exceed 20% tKC.

Undershoot Measurement and Timing

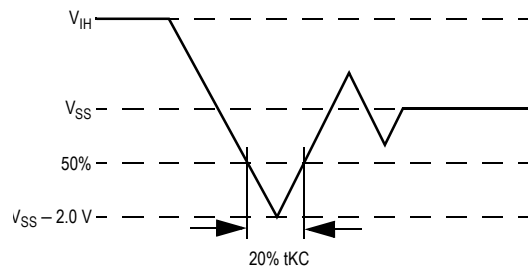

Overshoot Measurement and Timing

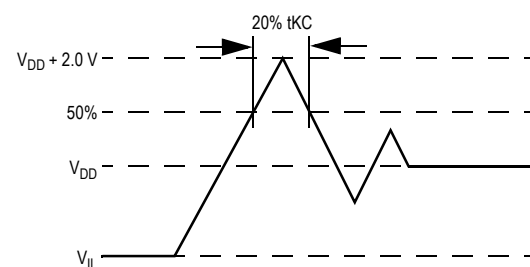

Capacitance

($T_A = 25^\circ\text{C}$, $f = 1\text{ MHz}$, $V_{DD} = 2.5\text{ V}$)

Parameter	Symbol	Test conditions	Typ.	Max.	Unit
Input Capacitance	C_{IN}	$V_{IN} = 0\text{ V}$	4	5	pF
Input/Output Capacitance	$C_{I/O}$	$V_{OUT} = 0\text{ V}$	6	7	pF

Note: These parameters are sample tested.

Package Thermal Characteristics

Rating	Layer Board	Symbol	Max	Unit	Notes
Junction to Ambient (at 200 lfm)	single	$R_{\Theta JA}$	40	°C/W	1,2
Junction to Ambient (at 200 lfm)	four	$R_{\Theta JA}$	24	°C/W	1,2
Junction to Case (TOP)	—	$R_{\Theta JC}$	9	°C/W	3

Notes:

- Junction temperature is a function of SRAM power dissipation, package thermal resistance, mounting board temperature, ambient. Temperature air flow, board density, and PCB thermal resistance.
- SCMI G-38-87
- Average thermal resistance between die and top surface, MIL SPEC-883, Method 1012.1

AC Test Conditions

Parameter	Conditions
Input high level	$V_{DD} - 0.2 V$
Input low level	0.2 V
Input slew rate	1 V/ns
Input reference level	$V_{DD}/2$
Output reference level	$V_{DDQ}/2$
Output load	Fig. 1

Notes:

1. Include scope and jig capacitance.
2. Test conditions as specified with output loading as shown in Fig. 1 unless otherwise noted.
3. Device is deselected as defined by the Truth Table.

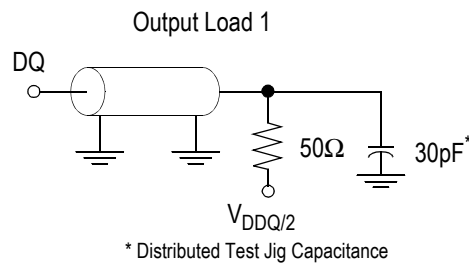

DC Electrical Characteristics

Parameter	Symbol	Test Conditions	Min	Max
Input Leakage Current (except mode pins)	I_{IL}	$V_{IN} = 0 \text{ to } V_{DD}$	-1 μA	1 μA
ZZ Input Current	I_{IN1}	$V_{DD} \geq V_{IN} \geq V_{IH}$ $0 V \leq V_{IN} \leq V_{IH}$	-1 μA -1 μA	1 μA 100 μA
Output Leakage Current	I_{OL}	Output Disable, $V_{OUT} = 0 \text{ to } V_{DD}$	-1 μA	1 μA
Output High Voltage	V_{OH2}	$I_{OH} = -8 \text{ mA}$, $V_{DDQ} = 2.3 V$	$V_{DDQ} - 0.4 V$	—
Output High Voltage	V_{OH1}	$I_{OH} = -4 \text{ mA}$, $V_{DDQ} = 1.6 V$	$V_{DDQ} - 0.4 V$	—
Output Low Voltage	V_{OL2}	$I_{OL} = 8 \text{ mA}$, $V_{DD} = 2.3 V$	—	0.4 V
Output Low Voltage	V_{OL1}	$I_{OL} = 4 \text{ mA}$, $V_{DD} = 1.6 V$	—	0.4 V

Operating Currents

Parameter	Test Conditions	Mode	Symbol	-300		-275		-250		-225		-200		Unit
				0 to 70°C	-40 to 85°C	0 to 70°C	-40 to 85°C	0 to 70°C	-40 to 85°C	0 to 70°C	-40 to 85°C			
Operating Current 2.5 V	Device Selected; All other inputs $\geq V_{IH}$ or $\leq V_{IL}$ Output open	(x32/ x36)	I_{DD} I_{DDQ}	345 30	355 30	315 30	325 30	290 30	600 60	265 30	275 30	240 25	250 25	mA
		(x18)	I_{DD} I_{DDQ}	305 15	315 15	285 15	295 15	260 15	270 15	235 15	245 15	215 15	225 15	
Operating Current 1.8 V	Device Selected; All other inputs $\geq V_{IH}$ or $\leq V_{IL}$ Output open	(x32/ x36)	I_{DD} I_{DDQ}	345 25	355 25	315 25	325 25	290 25	300 25	265 20	275 20	240 20	250 20	mA
		(x18)	I_{DD} I_{DDQ}	305 15	315 15	285 15	295 15	260 15	270 15	235 15	245 15	215 10	225 10	
Standby Current	$ZZ \geq V_{DD} - 0.2 V$	—	I_{SB}	35	45	35	45	35	45	35	45	35	45	mA
Deselect Current	Device Deselected; All other inputs $\geq V_{IH}$ or $\leq V_{IL}$	—	I_{DD}	95	100	90	95	85	90	80	85	75	80	mA

Notes:

- I_{DD} and I_{DDQ} apply to any combination of V_{DD3} , V_{DD2} , V_{DDQ3} , and V_{DDQ2} operation.
- All parameters listed are worst case scenario.

AC Electrical Characteristics

	Parameter	Symbol	-300		-275		-250		-225		-200		Unit
			Min	Max	Min	Max	Min	Max	Min	Max	Min	Max	
Pipeline	Clock Cycle Time	t _{KC}	3.3	—	3.6	—	4.0	—	4.4	—	5.0	—	ns
	Clock to Output Valid	t _{KQ}	—	1.7	—	1.9	—	2.0	—	2.2	—	2.5	ns
	Clock to Output Invalid	t _{KQX}	1.0	—	1.0	—	1.0	—	1.0	—	1.0	—	ns
	Clock to Output in Low-Z	t _{LZ} ¹	1.0	—	1.0	—	1.0	—	1.0	—	1.0	—	ns
	Clock HIGH Time	t _{KH}	1.0	—	1.3	—	1.3	—	1.3	—	1.3	—	ns
	Clock LOW Time	t _{KL}	1.2	—	1.5	—	1.5	—	1.5	—	1.5	—	ns
	Clock to Output in High-Z	t _{HZ} ¹	1.0	1.3	1.0	2.0	1.0	2.0	1.0	2.2	1.0	2.5	ns
	\bar{G} to Output Valid	t _{OE}	—	1.7	—	1.7	—	1.8	—	2.0	—	2.5	ns
	\bar{G} to output in Low-Z	t _{OLZ} ¹	0	—	0	—	0	—	0	—	0	—	ns
	\bar{G} to output in High-Z	t _{OHZ} ¹	—	1.5	—	1.8	—	1.8	—	2.0	—	2.5	ns
	Setup time	t _S	1.1	—	1.2	—	1.2	—	1.3	—	1.4	—	ns
	Hold time	t _H	0.1	—	0.2	—	0.2	—	0.3	—	0.4	—	ns
	ZZ setup time	t _{ZZS} ²	5	—	5	—	5	—	5	—	5	—	ns
	ZZ hold time	t _{ZZH} ²	1	—	1	—	1	—	1	—	1	—	ns
ZZ recovery	t _{ZZR}	20	—	20	—	20	—	20	—	20	—	ns	

Notes:

1. These parameters are sampled and are not 100% tested.
2. ZZ is an asynchronous signal. However, in order to be recognized on any given clock cycle, ZZ must meet the specified setup and hold times as specified above.

Write Cycle Timing

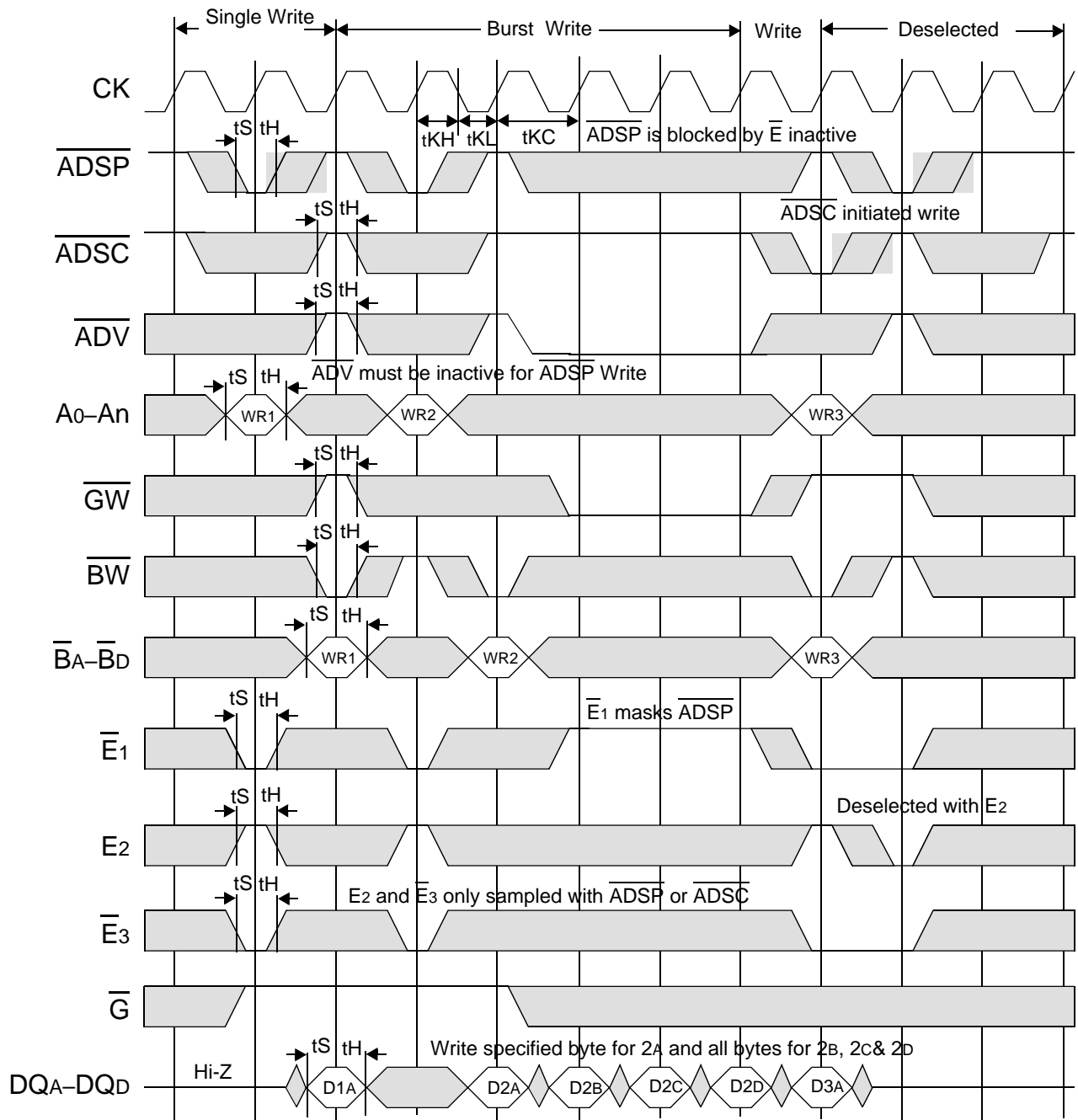

Pipelined SCD Read Cycle Timing

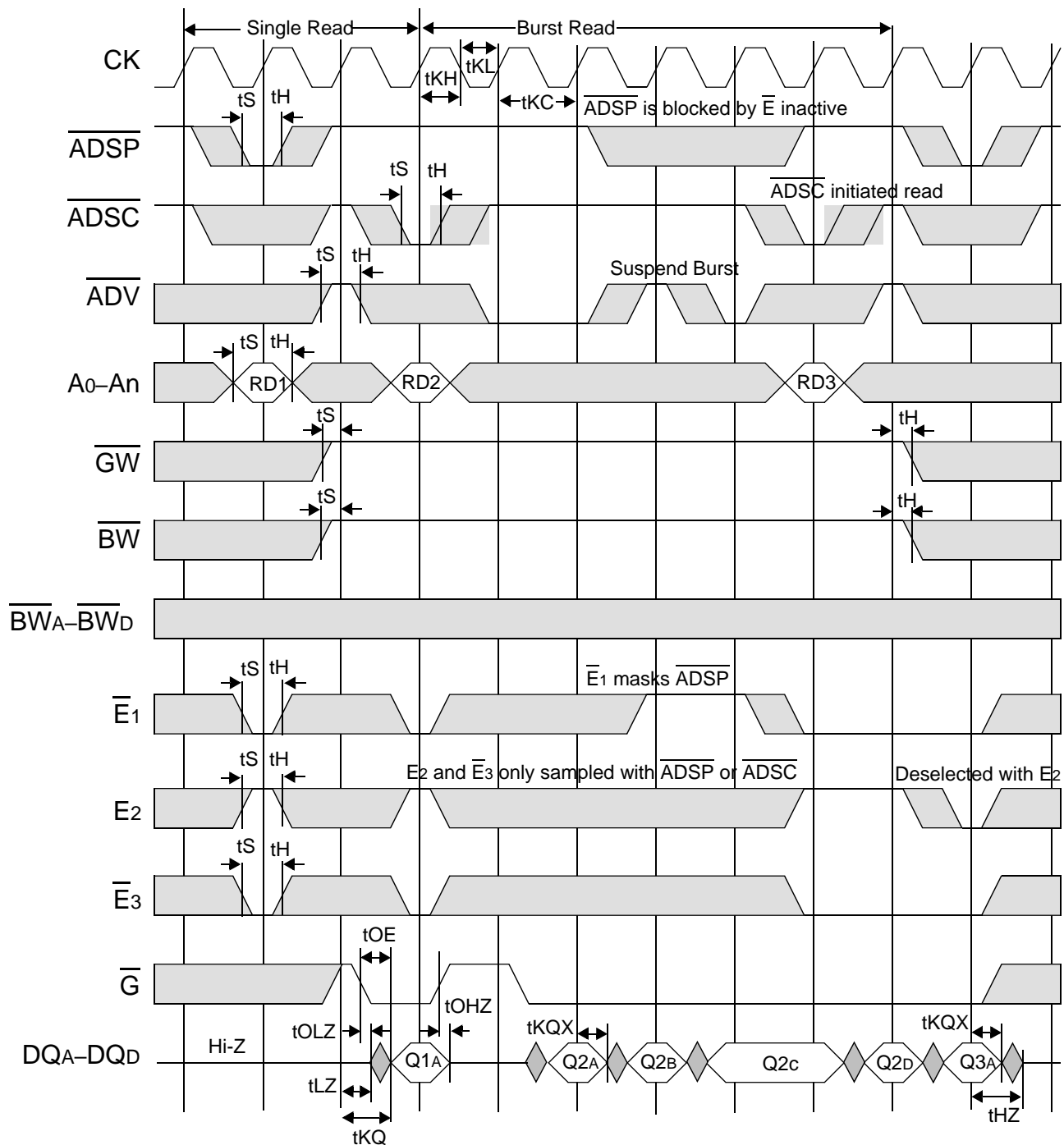

Pipelined SCD Read-Write Cycle Timing

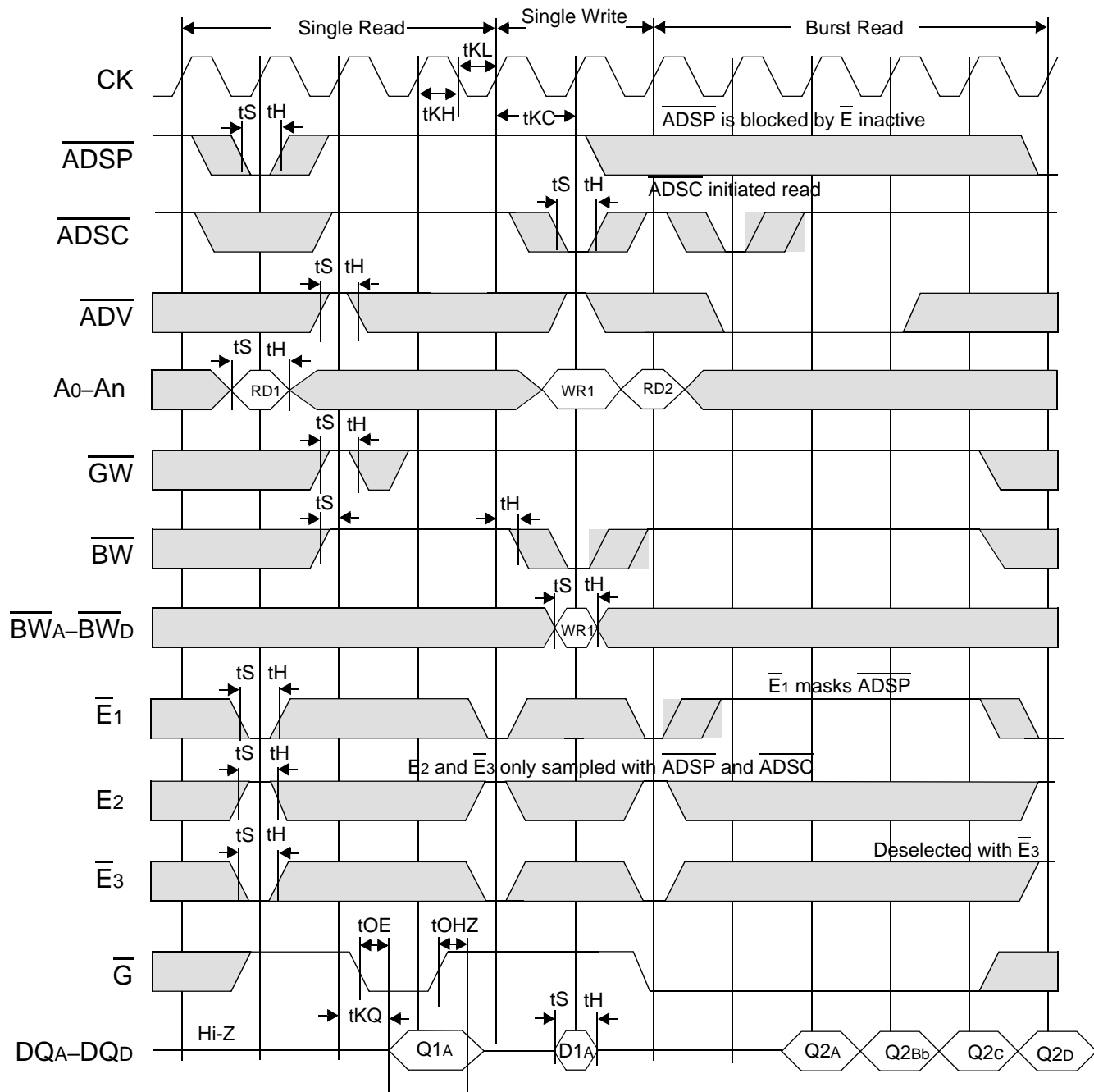

Sleep Mode

During normal operation, ZZ must be pulled low, either by the user or by its internal pull down resistor. When ZZ is pulled high, the SRAM will enter a Power Sleep mode after 2 cycles. At this time, internal state of the SRAM is preserved. When ZZ returns to low, the SRAM operates normally after ZZ recovery time.

Sleep mode is a low current, power-down mode in which the device is deselected and current is reduced to I_{SB2} . The duration of Sleep mode is dictated by the length of time the ZZ is in a High state. After entering Sleep mode, all inputs except ZZ become disabled and all outputs go to High-Z. The ZZ pin is an asynchronous, active high input that causes the device to enter Sleep mode. When the ZZ pin is driven high, I_{SB2} is guaranteed after the time t_{ZZI} is met. Because ZZ is an asynchronous input, pending operations or operations in progress may not be properly completed if ZZ is asserted. Therefore, Sleep mode must not be initiated until valid pending operations are completed. Similarly, when exiting Sleep mode during t_{ZZR} , only a Deselect or Read commands may be applied while the SRAM is recovering from Sleep mode.

Sleep Mode Timing Diagram

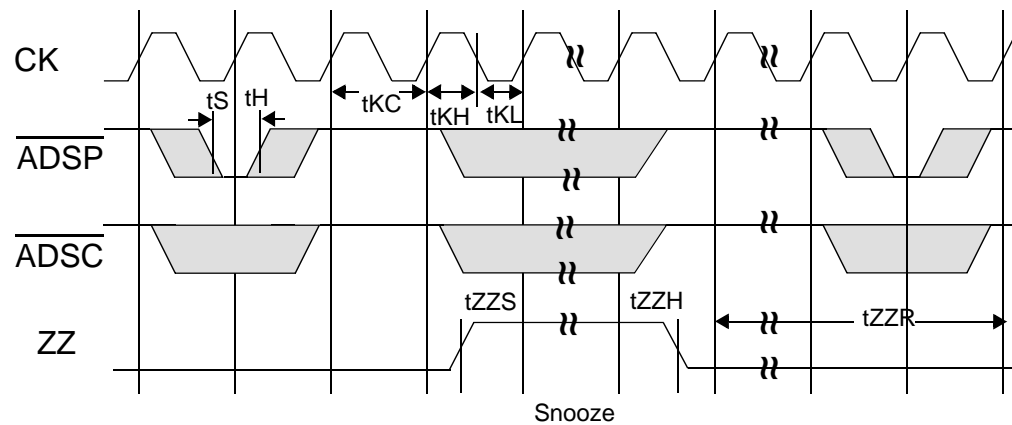

Application Tips

Single and Dual Cycle Deselect

SCD devices (like this one) force the use of “dummy read cycles” (read cycles that are launched normally but that are ended with the output drivers inactive) in a fully synchronous environment. Dummy read cycles waste performance but their use usually assures there will be no bus contention in transitions from reads to writes or between banks of RAMs. DCD SRAMs do not waste bandwidth on dummy cycles and are logically simpler to manage in a multiple bank application (wait states need not be inserted at bank address boundary crossings) but greater care must be exercised to avoid excessive bus contention.

TQFP Package Drawing

Symbol	Description	Min.	Nom.	Max
A1	Standoff	0.05	0.10	0.15
A2	Body Thickness	1.35	1.40	1.45
b	Lead Width	0.20	0.30	0.40
c	Lead Thickness	0.09	—	0.20
D	Terminal Dimension	21.9	22.0	22.1
D1	Package Body	19.9	20.0	20.1
E	Terminal Dimension	15.9	16.0	16.1
E1	Package Body	13.9	14.0	14.1
e	Lead Pitch	—	0.65	—
L	Foot Length	0.45	0.60	0.75
L1	Lead Length	—	1.00	—
Y	Coplanarity			0.10
θ	Lead Angle	0°	—	7°

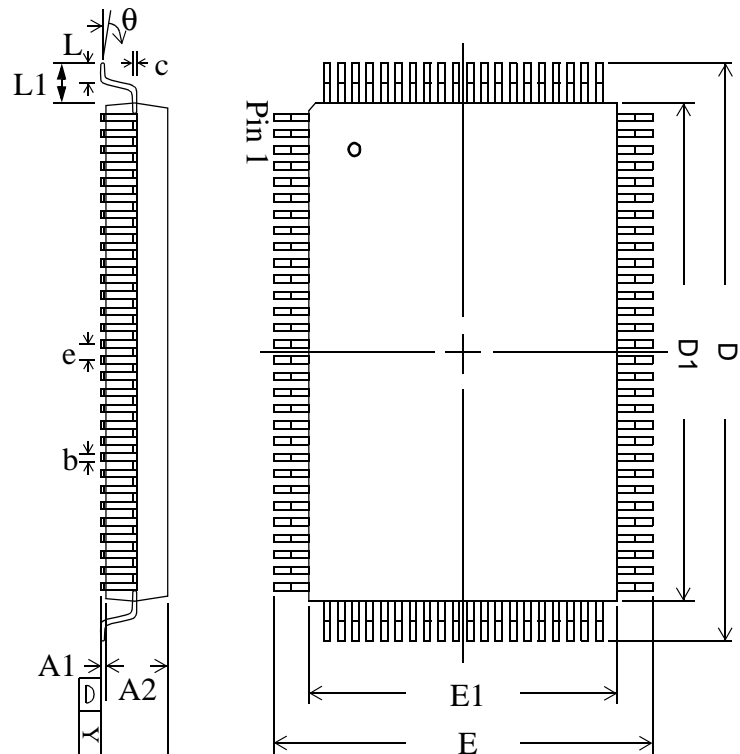

Notes:

1. All dimensions are in millimeters (mm).
2. Package width and length do not include mold protrusion.

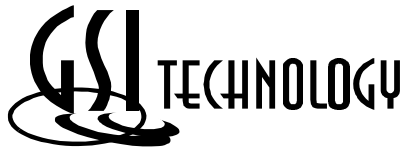

Ordering Information for GSI Synchronous Burst RAMs

Org	Part Number ¹	Type	Package	Speed ² (MHz)	T _A ³	Status
1M x 18	GS816019AT-300	Pipeline	TQFP	300	C	
1M x 18	GS816019AT-275	Pipeline	TQFP	275	C	
1M x 18	GS816019AT-250	Pipeline	TQFP	250	C	
1M x 18	GS816019AT-225	Pipeline	TQFP	225	C	
1M x 18	GS816019AT-200	Pipeline	TQFP	200	C	
512K x 32	GS816033AT-300	Pipeline	TQFP	300	C	
512K x 32	GS816033AT-275	Pipeline	TQFP	275	C	
512K x 32	GS816033AT-250	Pipeline	TQFP	250	C	
512K x 32	GS816033AT-225	Pipeline	TQFP	225	C	
512K x 32	GS816033AT-200	Pipeline	TQFP	200	C	
512K x 36	GS816037AT-300	Pipeline	TQFP	300	C	
512K x 36	GS816037AT-275	Pipeline	TQFP	275	C	
512K x 36	GS816037AT-250	Pipeline	TQFP	250	C	
512K x 36	GS816037AT-225	Pipeline	TQFP	225	C	
512K x 36	GS816037AT-200	Pipeline	TQFP	200	C	
1M x 18	GS816019AT-300I	Pipeline	TQFP	300	I	
1M x 18	GS816019AT-275I	Pipeline	TQFP	275	I	
1M x 18	GS816019AT-250I	Pipeline	TQFP	250	I	
1M x 18	GS816019AT-225I	Pipeline	TQFP	225	I	
1M x 18	GS816019AT-200I	Pipeline	TQFP	200	I	
512K x 32	GS816033AT-300I	Pipeline	TQFP	300	I	
512K x 32	GS816033AT-275I	Pipeline	TQFP	275	I	
512K x 32	GS816033AT-250I	Pipeline	TQFP	250	I	
512K x 32	GS816033AT-225I	Pipeline	TQFP	225	I	
512K x 32	GS816033AT-200I	Pipeline	TQFP	200	I	
512K x 36	GS816037AT-300I	Pipeline	TQFP	300	I	
512K x 36	GS816037AT-275I	Pipeline	TQFP	275	I	
512K x 36	GS816037AT-250I	Pipeline	TQFP	250	I	
512K x 36	GS816037AT-225I	Pipeline	TQFP	225	I	
512K x 36	GS816037AT-200I	Pipeline	TQFP	200	I	

Notes:

1. Customers requiring delivery in Tape and Reel should add the character "T" to the end of the part number. Example: GS816019AT-200IT.
2. T_A = C = Commercial Temperature Range. T_A = I = Industrial Temperature Range.
3. GSI offers other versions this type of device in many different configurations and with a variety of different features, only some of which are covered in this data sheet. See the GSI Technology web site (www.gsistechnology.com) for a complete listing of current offerings.

18Mb Sync SRAM Datasheet Revision History

DS/DateRev. Code: Old; New	Types of Changes Format or Content	Page;Revisions;Reason
816019A_r1		• Creation of new datasheet