

XT2116

FAST TURN-ON ASYMMETRIC THYRISTOR

APPLICATIONS

- Pulse Modulators.
- Laser Diode Triggering.
- Capacitor Discharge Applications.

KEY PARAMETERS

V_{DRM}	1600V
$I_{T(AV)}$	50A
I_{TSM}	800A
dI/dt	2000A/μs
dV/dt	300V/μs
t_{on}	350ns

FEATURES

- The XT2116 is Asymmetrical Thyristor in which the reverse voltage capability has been sacrificed to enable a high forward blocking characteristic combined with excellent turn-on performance.
- Designed for rapid and efficient switching of high current pulses.

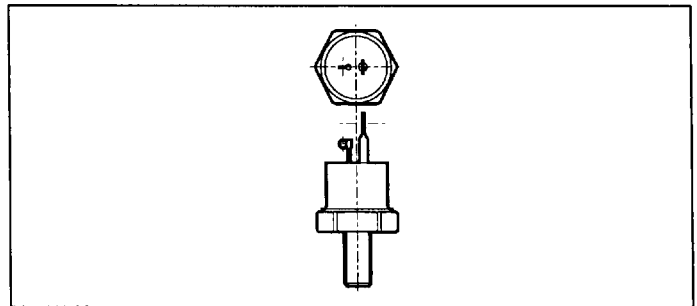

Outline type code: SO28. See package outlines for further information.

VOLTAGE RATINGS

Type Number	Max. Rise Time t_r ($T_{case} = 25^\circ C$) ns	Repetitive Peak Voltage		Peak Working Voltages	
		V_{DRM} V	V_{RRM}^* V	V_{DWM} V	V_{RWM}^* V
XT2116 - 1601	100	1600	< 2	1600	< 2
XT2116 - 1401	120	1400	< 2	1400	< 2
XT2116 - 1201	120	1200	< 2	1200	< 2
XT2116 - 1001	140	1000	< 2	1000	< 2
XT2116 - 801	160	800	< 2	800	< 2

CURRENT RATINGS

Symbol	Parameter	Conditions	Max.	Units
$I_{T(AV)}$	Mean on-state current	Half wave resistive load, $T_{case} = 80^\circ C$	50	A
$I_{T(RMS)}$	RMS value	$T_{case} = 80^\circ C$	79	A
I_T	Continuous (direct) on-state current	$T_{case} = 85^\circ C$	68	A

XT2116

SURGE RATINGS

Symbol	Parameter	Conditions	Max.	Units
I_{TSM}	Surge (non-repetitive) forward current	10ms half sine; $T_{case} = 125^{\circ}C$	800	A
I^2t	I^2t for fusing		3200	A ² s

THERMAL AND MECHANICAL DATA

Symbol	Parameter	Conditions	Min.	Max.	Units
$R_{th(j-c)}$	Thermal resistance - junction to case	d.c.	-	0.35	$^{\circ}C/W$
$R_{th(c-h)}$	Thermal resistance - case to heatsink	Mounting torque 3.5Nm with mounting compound	-	0.25	$^{\circ}C/W$
T_{vj}	Virtual junction temperature	On-state (conducting)	-	125	$^{\circ}C$
T_{stg}	Storage temperature range		-55	125	$^{\circ}C$
-	Mounting torque		3.5*	4.0	Nm

* Recommended value.

DYNAMIC CHARACTERISTICS

$T_{case} = 25^{\circ}C$ unless otherwise stated.

Symbol	Parameter	Conditions	Typ.	Max.	Units
V_{TM}	Maximum on-state voltage	At $I_T = 100A$	-	2.0	V
I_{RRM}/I_{DRM}	Peak reverse and off-state current	At V_{RRM}/V_{DRM}	-	10/10	mA
dV/dt	Maximum linear rate of rise of off-state voltage	$T_j = 125^{\circ}C$, $T_o V_{DRM}$, $R_{GK} = 47\Omega$	-	300	V/ μs
dI/dt	Rate of rise of on-state current	Half sine wave of $2\mu s$, $T_j = 125^{\circ}C$ Gate source 20V, 10Ω , $t_f = 160ns$	-	2000	A/ μs
I_L	Latching current	-	45	-	mA
I_H	Holding current	-	35	-	mA
t_d	Delay time	$V_D = 400V$, gate source = 500mA, $t_f = 50ns$	-	250	ns
t_q	Circuit commutated turn-off time	$I_T = 25A$, $V_{RM} = 0V$, $V_{DR} = V_{DWM}$, $T_{case} = 120^{\circ}C$, $R_{GK} = 47\Omega$, $dV/dt = 100V/\mu s$.	-	120†	μs

† Available to 10 μs .

GATE TRIGGER CHARACTERISTICS AND RATINGS

$T_{case} = 25^{\circ}C$ unless otherwise stated.

Symbol	Parameter	Conditions	Typ.	Max.	Units
V_{GT}	Gate trigger voltage	$V_{DWM} = 12V$	0.9	3.0	V
I_{GT}	Gate trigger current	$V_{DWM} = 12V$	-	100*	mA
V_{FGM}	Peak forward gate voltage	-	-	40	V
V_{RGM}	Peak reverse gate voltage	-	-	10	V
I_{FGM}	Peak forward gate current	-	-	10	A
P_{GM}	Peak gate power	-	-	40	W
$P_{G(AV)}$	Average gate power	-	-	10	W

*Recommended trigger current not less than 500mA, $t_r < 50ns$.

XT2116

PACKAGE DETAILS - SO28

For further package information, please contact your local Customer Service Centre. All dimensions in mm, unless stated otherwise. DO NOT SCALE.

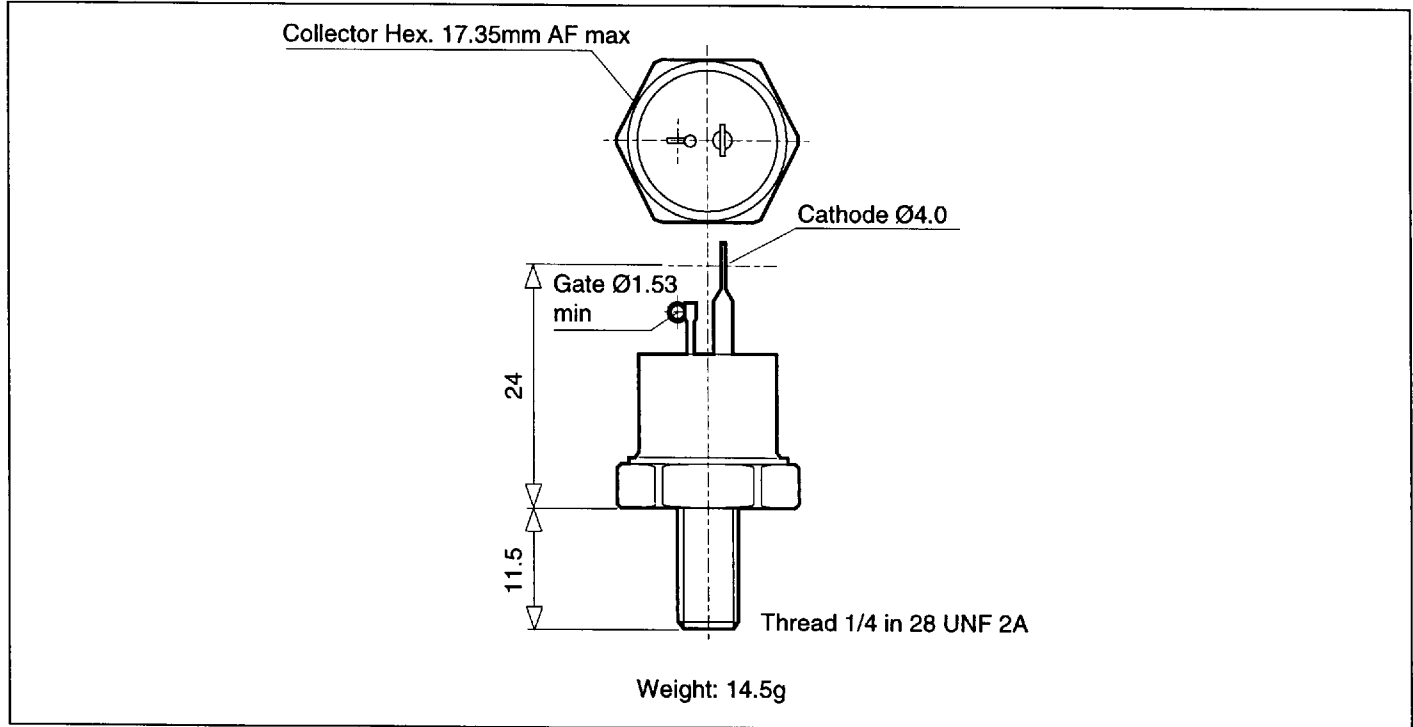

HEADQUARTERS OPERATIONS
GEC PLESSEY SEMICONDUCTORS
Cheney Manor, Swindon,
Wiltshire, SN2 2QW, United Kingdom.
Tel: + 44 (0)1793 518000
Fax: + 44 (0)1793 518411

GEC PLESSEY SEMICONDUCTORS
P.O. Box 660017
1500 Green Hills Road,
Scotts Valley, California 95066-4922,
United States of America.
Tel: + 1 (408) 438 2900
Fax: + 1 (408) 438 5576

Internet: <http://www.gpsemi.com>

POWER PRODUCT CUSTOMER SERVICE CENTRES

- **FRANCE & BENELUX.** 2 rue Henri-Bergson, 92665 Asnieres Cedex.
Tel: + 33 1 40 80 54 00. Fax: + 33 1 40 80 55 87.
- **GERMANY.** Ungererstrasse 129, 80505 München.
Tel: + 49 (0)89 36 09 060. Fax: + 49 (0)89 36 09 06 55.
- **NORTH AMERICA.** Two Dedham Place, Suite 125, 3 Allied Drive, Dedham. MA 02026.
Tel: + 1 617 251 0126. Fax: + 1 617 251 0106.
- **UNITED KINGDOM.** Doddington Road, Lincoln. LN6 3LF.
Tel: + 44 (0)1522 500500. Fax: + 44 (0)1522 510550.

These are supported by Agents and Distributors in major countries world-wide.

© GEC Plessey Semiconductors 1997 Publication No. DS4674-2 Issue No. 2.1 January 1997
TECHNICAL DOCUMENTATION - NOT FOR RESALE. PRINTED IN UNITED KINGDOM.

This publication is issued to provide information only which (unless agreed by the Company in writing) may not be used, applied or reproduced for any purpose nor form part of any order or contract nor to be regarded as a representation relating to the products or services concerned. No warranty or guarantee express or implied is made regarding the capability, performance or suitability of any product or service. The Company reserves the right to alter without prior notice the specification, design or price of any product or service. Information concerning possible methods of use is provided as a guide only and does not constitute any guarantee that such methods of use will be satisfactory in a specific piece of equipment. It is the user's responsibility to fully determine the performance and suitability of any equipment using such information and to ensure that any publication or data used is up to date and has not been superseded. These products are not suitable for use in any medical products whose failure to perform may result in significant injury or death to the user. All products and materials are sold and services provided subject to the Company's conditions of sale, which are available on request.