

CA3275

Dual Full Bridge Driver

FN2159
Rev 3.00
April 1994

Features

- Two Full Bridge Drivers
- $\pm 150\text{mA}$ Maximum Current
- Logic Controlled Switching
- Direction Control
- PWM I_{OUT} Control
- 18V Over-Voltage Protection
- 300mA Short-Circuit Protection
- Nominal 8V to 16V Operation
- Internal Voltage Regulation With Bandgap Reference

Applications

- Dual Full Bridge Driver For Air Core Gauge Instrumentation
- μP Controlled Sensor Data Displays
- Speedometer Displays
- Tachometer Displays
- Stepper Motors
- Slave Position Indicators

Description

The CA3275 Dual Full Bridge Driver is intended for general-purpose applications requiring Dual Full Bridge drive or switching, including direction and pulse-width modulation for position control. While all features of the IC may not be utilized or required, they would normally be used in instrumentation systems with quadrature coils, such as air-core gauges, where the coils would be driven at frequencies ranging from 200Hz to 400Hz. The coils are wrapped at 90° angles for independent direction control. Coils wound in this physical configuration are controlled by pulse width modulation, where each coil drive is a function of the sine or cosine versus degrees of movement. The direction control is used to change the direction of the current in the H-Driver coil.

The switch rate capability of the IC is typically 30kHz regardless of the inductive load. Over-current limiting is used to limit short circuit current. Over-voltage protection (in the range of 18V to 24V) causes the device to shut down the output current drive. Thermal shutdown limits power dissipation on the chip. The CA3275 is supplied in a 14 lead dual-in-line plastic package.

Ordering Information

PART NO.	TEMPERATURE	PACKAGE
CA3275E	-40°C to +85°C	14 Lead Plastic DIP

Pinout

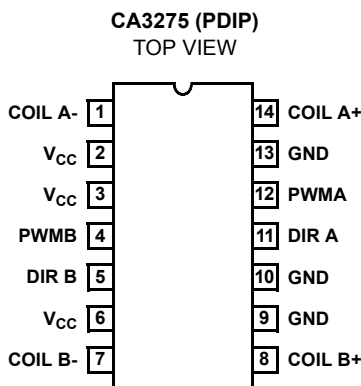

Block Diagram

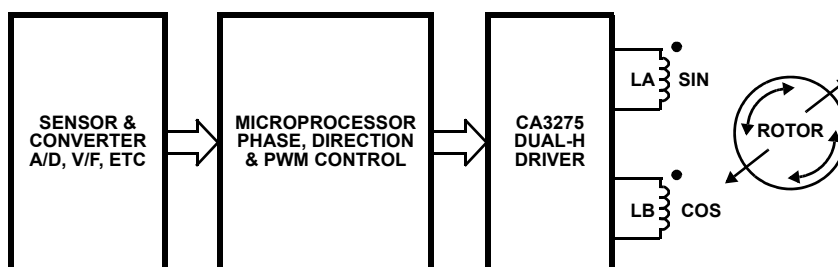

Absolute Maximum Ratings

Operating V_{CC}	16V
Transient V_{CC} , 30 Seconds Maximum	24V
Peak V_{CC} , 0.4 Seconds Maximum	40V
Maximum Continuous Output Current,	± 100 mA
Each Drive	
Maximum PWM Output Switching Current,	± 150 mA
Each Drive	

Thermal Information

Thermal Resistance	θ_{JA}
PDIP Package	100°C/W
Power Dissipation, P_D	
Up to +70°C	800mW
Above +70°C	Derate Linearly at 10mW/°C
Ambient Temperature Range	
Operating	-40°C to +85°C
Storage	-55°C to +150°C
Lead Temperature (During Soldering)	+265°C
At distance 1/16 \pm 1/32" (1.59 \pm 0.79mm) from case for	10s max

CAUTION: Stresses above those listed in "Absolute Maximum Ratings" may cause permanent damage to the device. This is a stress only rating and operation of the device at these or any other conditions above those indicated in the operational sections of this specification is not implied.

Electrical Specifications $T_A = -40^\circ\text{C}$ to $+85^\circ\text{C}$, $V_{CC} = 16\text{V}$ Unless Otherwise Specified

PARAMETERS	SYMBOL	MIN	TYP	MAX	UNITS
Operating Supply Voltage Range	V_{CC}	8	-	16	V
Supply Current (Note 1)	I_{CC}	-	8	20	mA
INPUT LEVELS					
Logic Input, Low Voltage	V_{IL}	-	-	0.8	V
Logic Input, High Voltage	V_{IH}	3.5	-	-	V
Logic Input, Low Current, $V_{IL} = 0\text{V}$	I_{IL}	-10	-	-	μA
Logic Input, High Current, $V_{IH} = 5\text{V}$	I_{IH}	-	-	10	μA
OUTPUT: $R_{LA} = R_{LB} = 138\Omega$					
Maximum Source Saturated Voltage	$V_{SAT} - \text{High}$	-	1.2	1.75	V
Maximum Sink Saturated Voltage	$V_{SAT} - \text{Low}$	-	0.25	0.5	V
Differential V_{SAT} Voltage, Both Outputs Saturated	Diff - V_{SAT}	-	10	100	mV

Switching Specifications

PARAMETERS	SYMBOL	MIN	TYP	MAX	UNITS
SOURCE CURRENT (See Figure 3)					
Turn-Off Delay	T_{SC-OFF}	-	-	2	μs
Fall Time	T_{SC-F}	-	-	2.2	μs
Turn-On Time	T_{SC-ON}	-	-	1	μs
Rise Time	T_{SC-R}	-	-	0.4	μs
SINK CURRENT (See Figure 4)					
Turn-Off Delay	T_{SK-OFF}	-	-	1.6	μs
Fall Time	T_{SK-F}	-	-	0.4	μs
Turn-On Time	T_{SK-ON}	-	-	0.6	μs
Rise Time	T_{SK-R}	-	-	0.2	μs

NOTE:

1. No load, $PWMA = PWMB = 5\text{V}$, $DIR A = DIR B = 0\text{V}$

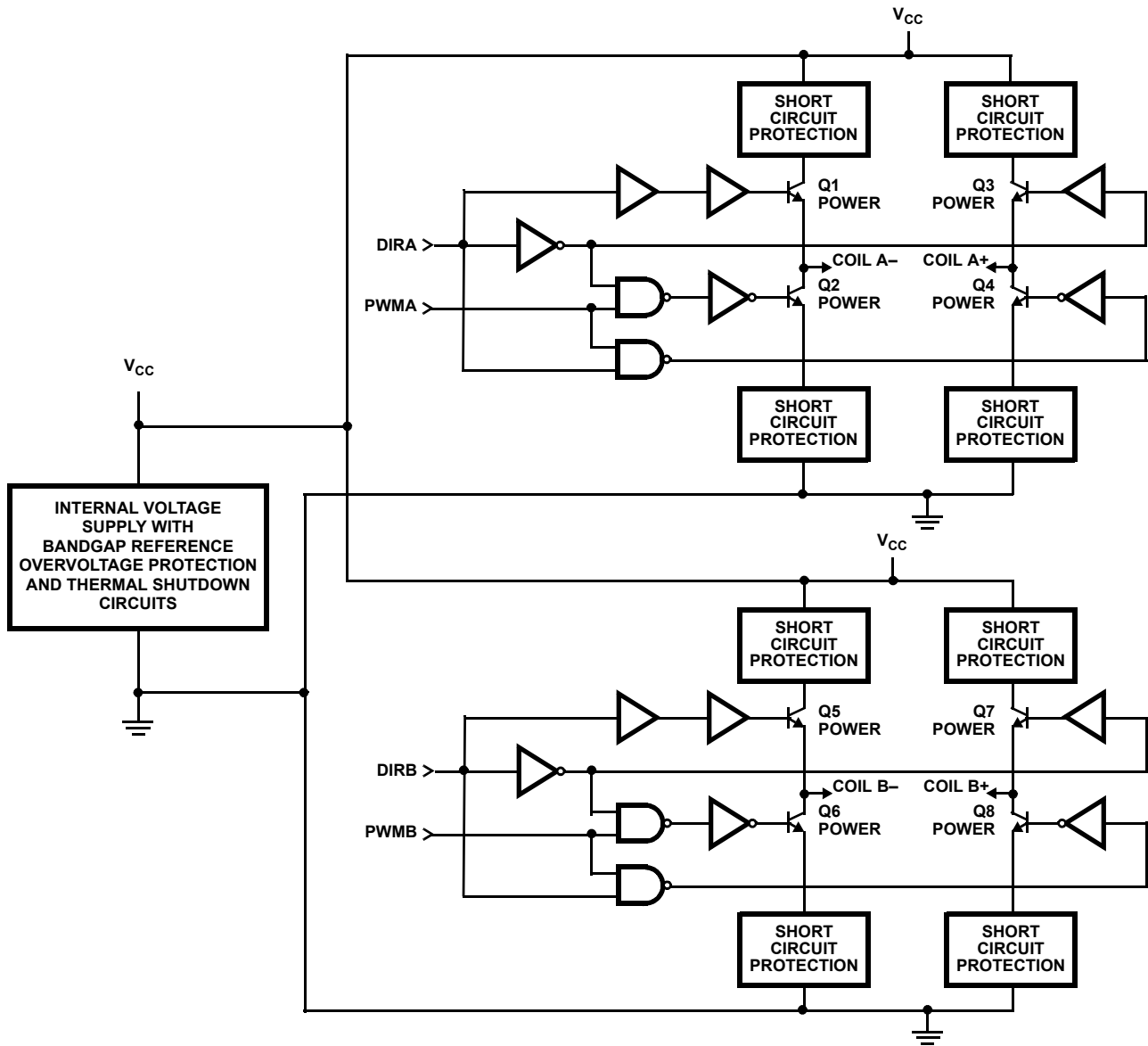

FIGURE 1. CA3275 DUAL FULL BRIDGE DRIVER SCHEMATIC

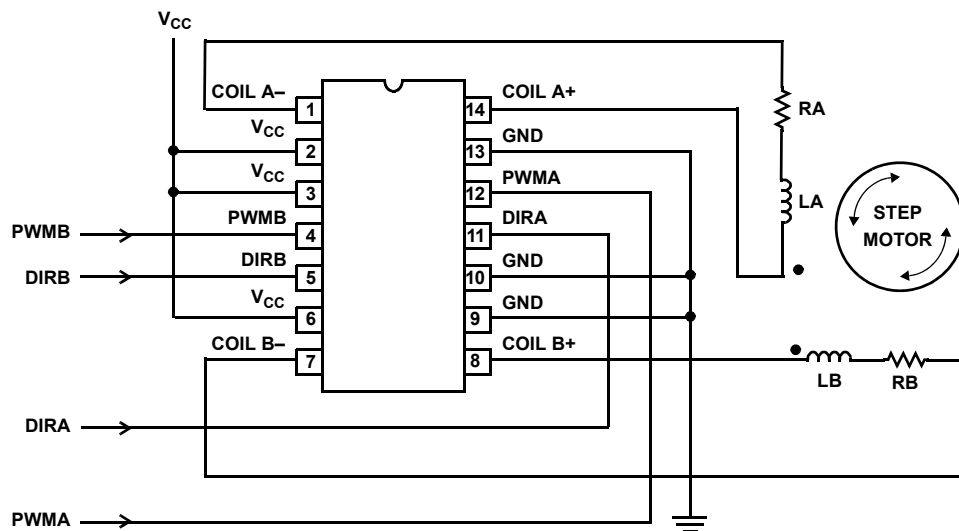

FIGURE 2. QUADRATURE STEP-MOTOR APPLICATION SCHEMATIC

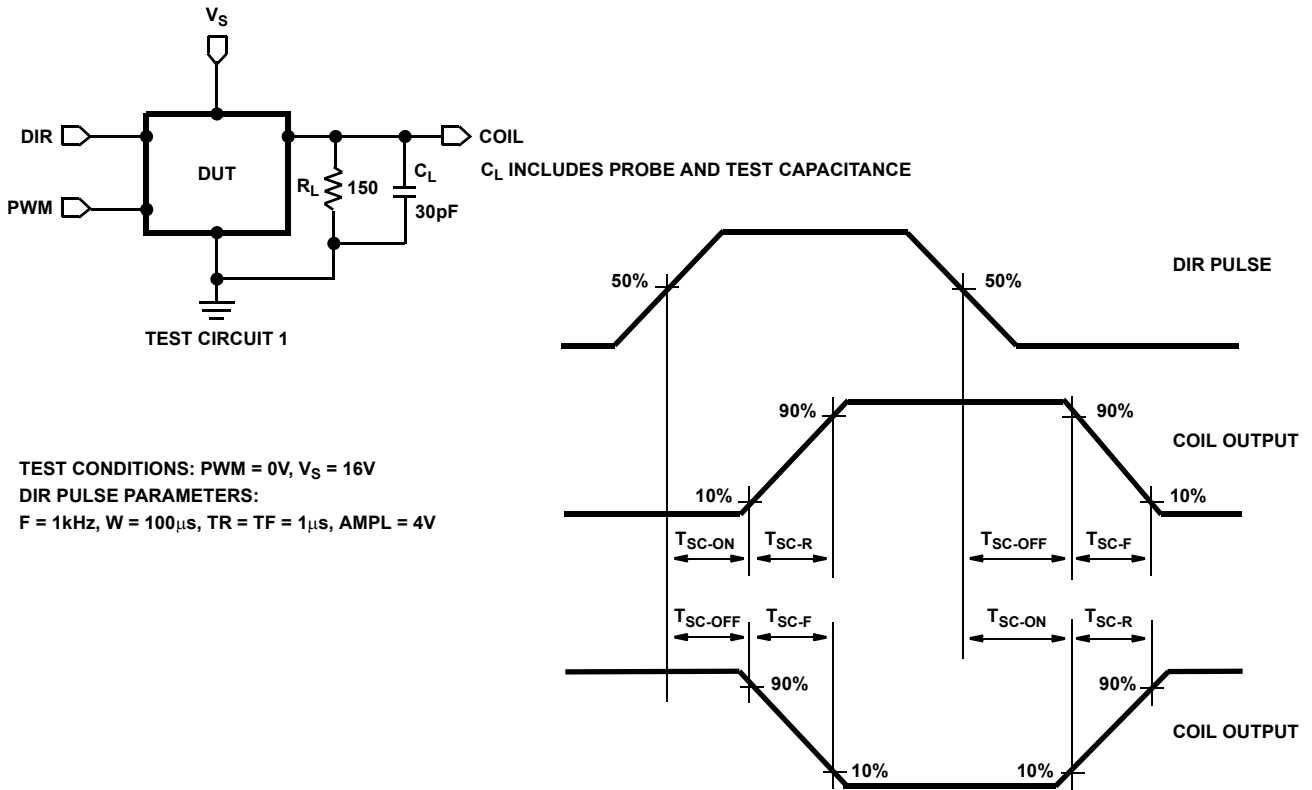

FIGURE 3. SOURCE SWITCHING TEST CIRCUIT AND VOLTAGE WAVEFORMS

TEST CONDITIONS: V_s = 16V
 DIR = 0V WHEN TESTING COIL - OUTPUT
 DIR = 4V WHEN TESTING COIL + OUTPUT

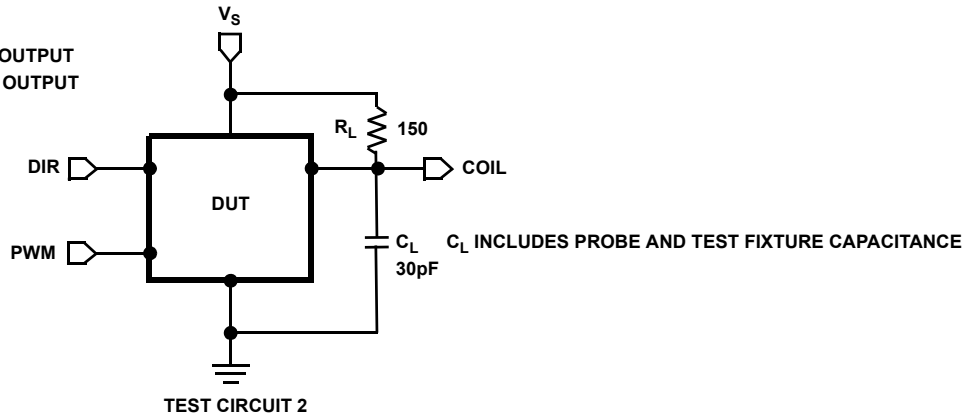

FIGURE 4. SINK SWITCHING TEST CIRCUIT AND VOLTAGE WAVEFORMS

© Copyright Intersil Americas LLC 2005-2017. All Rights Reserved.
All trademarks and registered trademarks are the property of their respective owners.

For additional products, see www.intersil.com/en/products.html

Intersil products are manufactured, assembled and tested utilizing ISO9001 quality systems as noted in the quality certifications found at www.intersil.com/en/support/qualandreliability.html

Intersil products are sold by description only. Intersil may modify the circuit design and/or specifications of products at any time without notice, provided that such modification does not, in Intersil's sole judgment, affect the form, fit or function of the product. Accordingly, the reader is cautioned to verify that datasheets are current before placing orders. Information furnished by Intersil is believed to be accurate and reliable. However, no responsibility is assumed by Intersil or its subsidiaries for its use; nor for any infringements of patents or other rights of third parties which may result from its use. No license is granted by implication or otherwise under any patent or patent rights of Intersil or its subsidiaries.

For information regarding Intersil Corporation and its products, see www.intersil.com