

FEATURES

- **TWO BUILT-IN DIFFERENTIAL AMPLIFIER CIRCUITS:** (9 GHz Single Transistors)
- **OUTSTANDING h_{FE} LINEARITY**
- **TWO PACKAGE OPTIONS:**
UPA102B: Superior thermal dissipation due to studded 14-pin ceramic package
UPA102G: Reduced circuit size due to 14-pin mini-flat package for surface mounting

CONNECTION DIAGRAM (Top View)

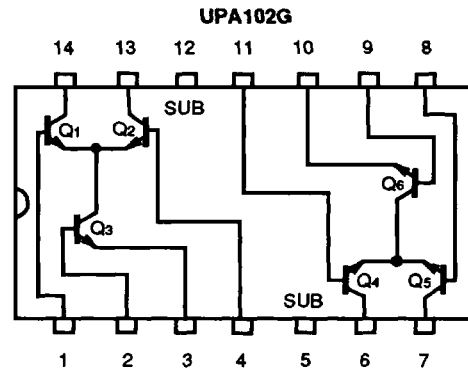
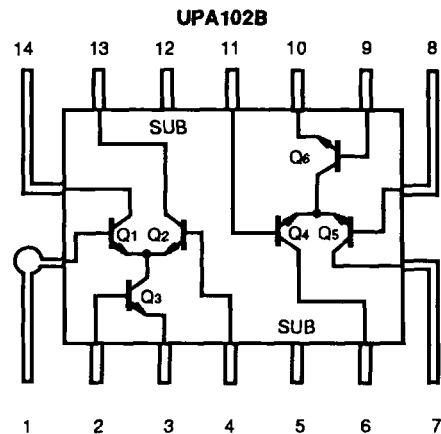

DESCRIPTION

The UPA102B/G is a user configurable Silicon MMIC transistor array consisting of two separate differential amplifiers. It is available in a surface mount (mini-flat) package and a 14-pin ceramic package. Typical applications include: pulse pattern generators, oscillators, differential amps, high speed comparators, electro-optic signal processing up to 1 Gigabits/second, and advanced cellular phone systems.

ELECTRICAL CHARACTERISTICS ($T_A = 25^\circ\text{C}$)

PART NUMBER PACKAGE OUTLINE			UPA102B, UPA102G BS14, G14		
SYMBOLS	PARAMETERS AND CONDITIONS	UNITS	MIN	TYP	MAX
ICBO	Collector Cut-off Current at $V_{CB} = 5\text{ V}$, $I_E = 0$ (Q1, Q2, Q4, Q5)	μA			1.0
IEBO	Emitter Cut-off Current at $V_{EB} = 1\text{ V}$, $I_C = 0$ (Q3 and Q6)	μA			1.0
h_{FE}	Direct Current Amplification, $V_{CE} = 3\text{ V}$, $I_C = 1\text{ mA}$ (Q3 and Q6)		40	100	250
h_{FE1}/h_{FE2}	Direct Current Amplification Ratio, $V_{CE} = 3\text{ V}$, $I_C = 1\text{ mA}$, (Q3 and Q6)		0.9	1.0	1.1
CCB	Collector to Base Capacitance at $V_{CB} = 3\text{ V}$, $f = 1\text{ MHz}$ (Q1, Q2, Q4, Q5)	pF		0.9	1.8
CEB	Emitter to Base Capacitance at $V_{EB} = 0$, $f = 1\text{ MHz}$ (Q3 and Q6)	pF		1.4	2.8
CCS	Collector/Substrate Capacitance at $V_{CS} = 3\text{ V}$, $f = 1\text{ MHz}$ (Q1, Q2, Q4, Q5)	pF		1.4	2.8
f_T	Gain Bandwidth Product at $V_{CE} = 3\text{ V}$, $I_C = 10\text{ mA}$	GHz		9.0	
RTH	Thermal Resistance, Single Transistor, G14 Package	$^\circ\text{C/W}$			40
	Whole Device, G14 Package	$^\circ\text{C/W}$			25

Note:

1. Measured by installing a single transistor in a Micro-X package: the value shown is a reference value.

ABSOLUTE MAXIMUM RATINGS¹ (T_A = 25°C)

SYMBOLS	PARAMETERS	UNITS	RATINGS
V _{CB0} ²	Collector to Base Voltage	V	15
V _{CE0} ²	Collector to Emitter Voltage	V	6
V _{EB0} ²	Emitter to Base Voltage	V	2.5
I _C ²	Collector Current	mA	40
P _T	Total Power Dissipation		
	UPA102B	mW	650
	UPA102G	mW	350
T _J	Junction Temperature		
	UPA102B	°C	200
	UPA102G	°C	125
T _{STG}	Storage Temperature		
	UPA102B	°C	-55 to +200
	UPA102G	°C	-55 to +125

Note:

1. Operation in excess of any one of these conditions may result in permanent damage.
2. Absolute maximum ratings for each transistor.

TYPICAL PERFORMANCE CURVES (T_A = 25°C)

TEST CIRCUIT SCHEMATIC*

(For Electrical Characteristics Measurements excluding f_T)

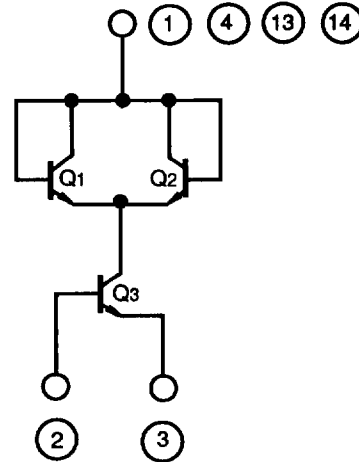

*See performance characteristics for voltage.

COLLECTOR CURRENT vs. PIN 1 TO PIN 3 VOLTAGE

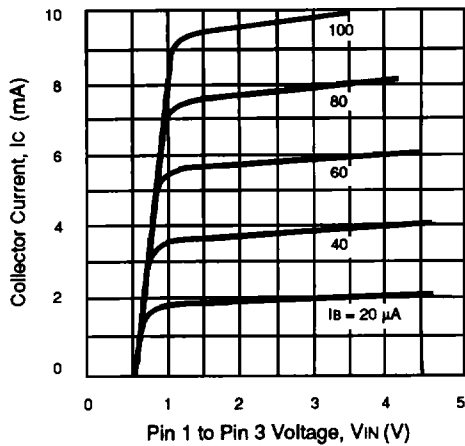

COLLECTOR CURRENT vs. BASE TO EMITTER VOLTAGE

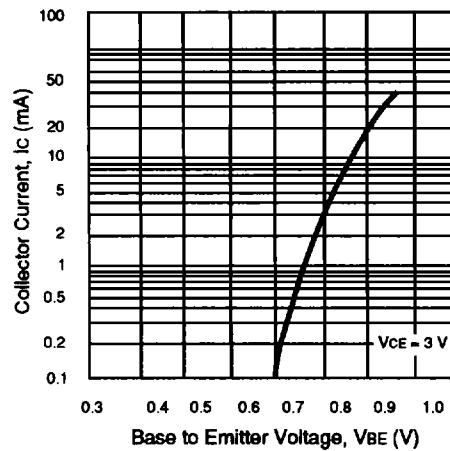

DC CURRENT GAIN vs. COLLECTOR CURRENT

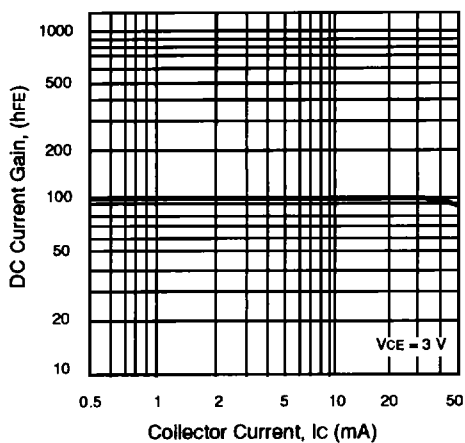

GAIN BANDWIDTH PRODUCT vs. COLLECTOR CURRENT

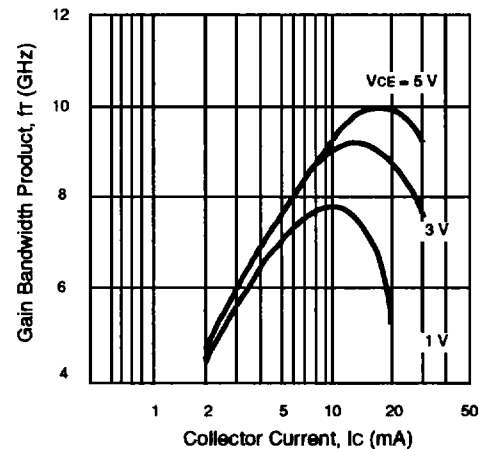

UPA102B, UPA102G

TYPICAL PERFORMANCE CURVES (TA = 25°C)

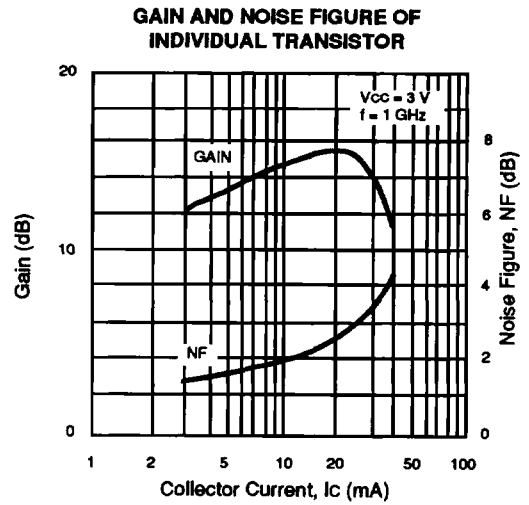
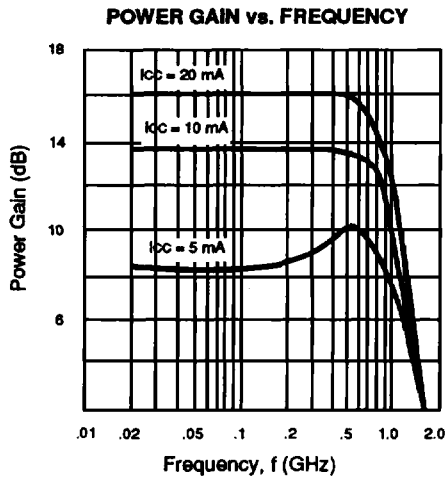

OUTLINE DIMENSIONS (Units in mm)

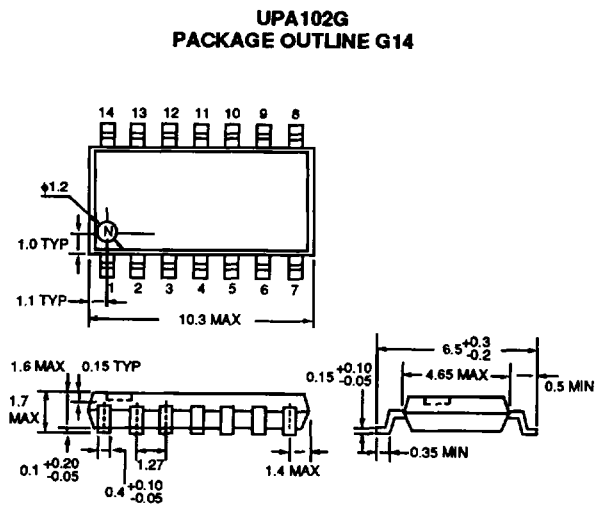
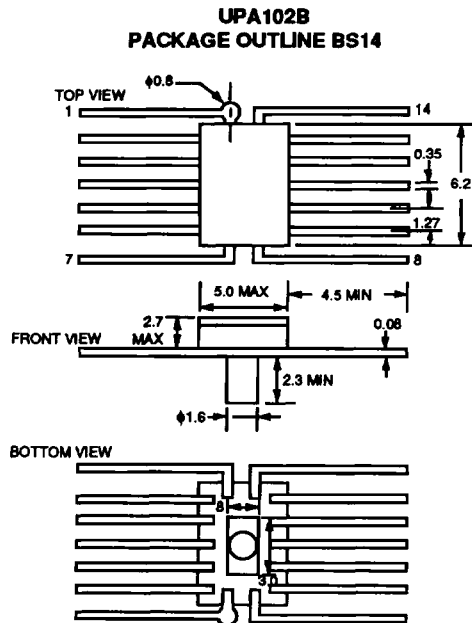

See Connection Diagram for description of leads.