

K2xx0yHU Series

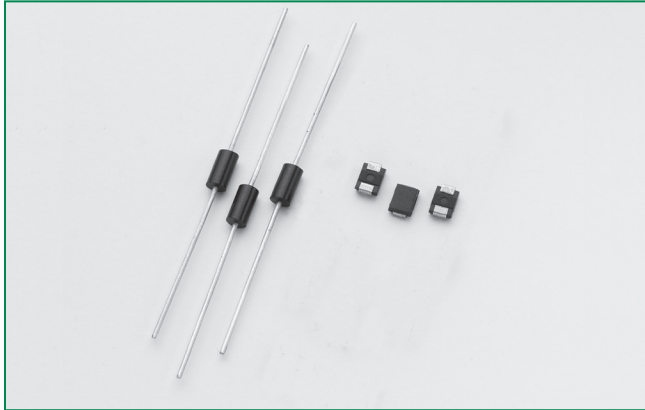

Schematic Symbol

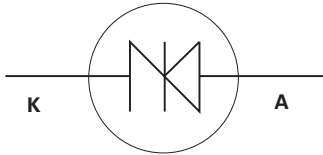

Description

The new K2xx0yHU is a higher energy SIDAC switch for gas ignition applications requiring higher current pulse current especially at low repetition rate. It is offered in a DO-15 leaded package and DO-214AA surface mount package. Voltage activation of this solid state switch is accomplished with peak voltage level of 190 to 260Volts. The SIDAC is a silicon bilateral voltage triggered Thyristor switch that switches on through a negative resistance region to a low on-state voltage. Conduction will continue until current is interrupted or lowered below minimum holding current of the device.

Features

- AC circuit oriented
- RoHS compliant
- Triggering Voltage of 190 to 260V
- Unidirectional
- 280A Pulse current capability

Applications

Suitable for high voltage power supplies, natural gas igniters, and Xenon flash ignition.

Electrical Specifications ($T_J = 25^\circ\text{C}$, unless otherwise specified)

Symbol	Parameters	Test Conditions	Min	Max	Unit
V_{BO}	Breakover/Trigger Voltage	K2000yHU	190	210	V
		K2200yHU	210	230	
		K2400yHU	230	250	
		K2500yHU	240	260	
V_{DRM}	Repetitive Peak Off-state Voltage	K2000yHU	180		V
		K2200yHU	190		
		K2400yHU	210		
		K2500yHU	220		
$I_{T(RMS)}$	On-state RMS Current	50/60Hz, $T_J < 125^\circ\text{C}$		1	A
V_{TM}	Peak On-state Voltage	$I_T = 1\text{A}$		1.5	V
I_H	Dynamic Holding Current	$R_T = 100\Omega$ 50/60Hz Sine Wave		60	mA
R_S	Switching Resistance, $R_S = \frac{(V_{BO} - V_S)}{(I_S - I_{BO})}$	50/60Hz Sine Wave	100		Ω
I_{BO}	Breakover Current	50/60Hz Sine Wave		500	μA
I_{TRM}	Peak Repetitive Pulse Current (refer to figure 4)	$t_p = 10\mu\text{s}$	60Hz	120	A
			5Hz	280	
di/dt	Critical Rate of Rise of On-State Current			220	A/ μs
dv/dt	Critical Rate of Rise of Off-State Voltage		1500		V/ μs
T_S	Storage Temperature Range		-40	150	$^\circ\text{C}$
T_J	Junction Temperature Range		-40	125	$^\circ\text{C}$
$R_{\theta JL}$	Thermal Resistance, Junction to Lead	DO-15		18	$^\circ\text{C}/\text{W}$
		DO-214AA		30	
$R_{\theta JA}$	Thermal Resistance, Junction to Ambient	DO-15		75	$^\circ\text{C}/\text{W}$

Note: xxx - voltage, y = package

Figure 1: V-I Characteristics

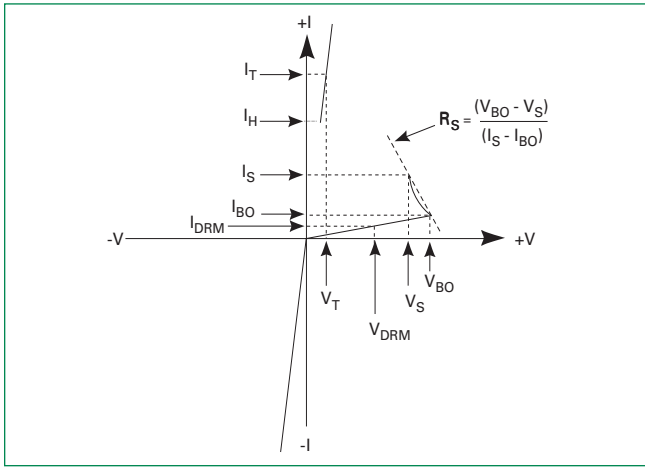

Figure 2: On-state Current vs. On-state Voltage (Typical)

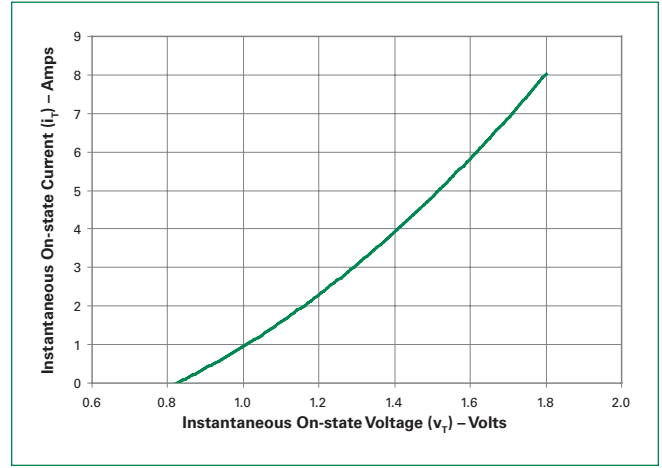

Figure 3: Power Dissipation vs. On-state Current (Typical)

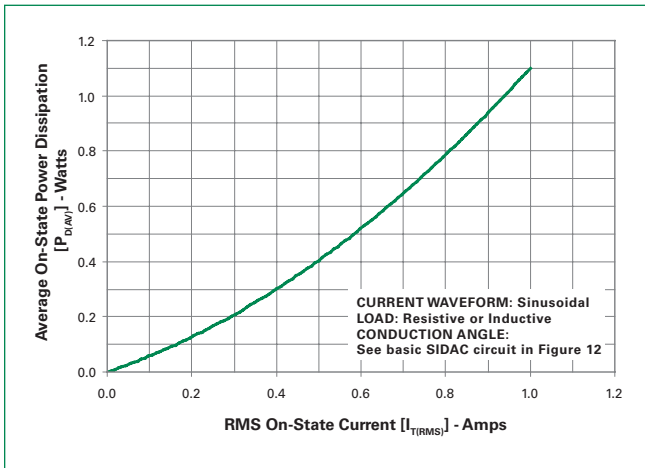

Figure 4: Repetitive Peak On-state Current (I_{TRM}) vs. Pulse Width at Various Frequencies

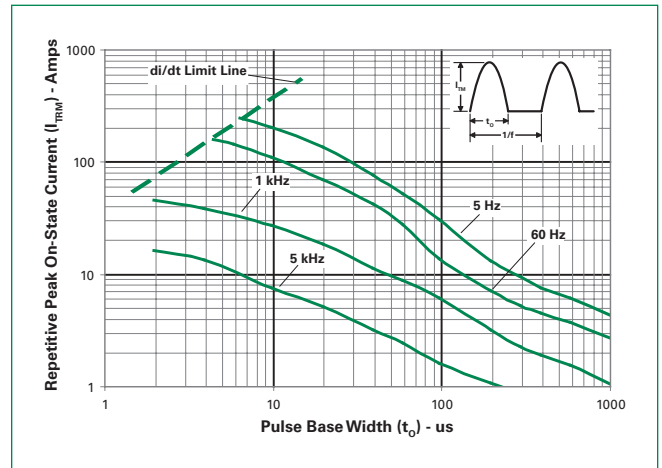

Figure 5: Surge Peak On-state Current vs. Number of Cycles

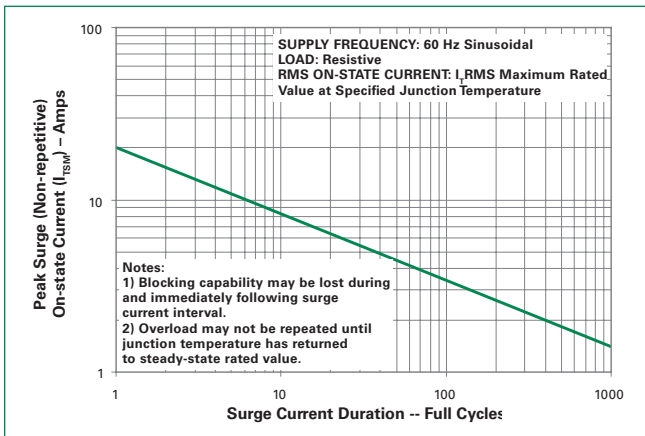

Figure 6: Normalized V_{BO} Change vs. Junction Temperature

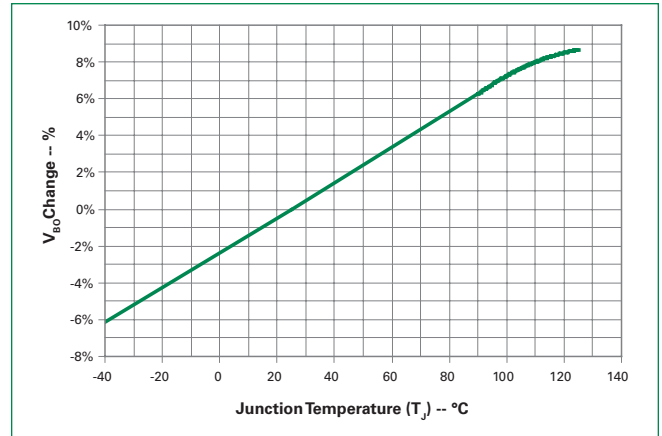

Figure 7: Normalized DC Holding Current vs. Junction Temperature

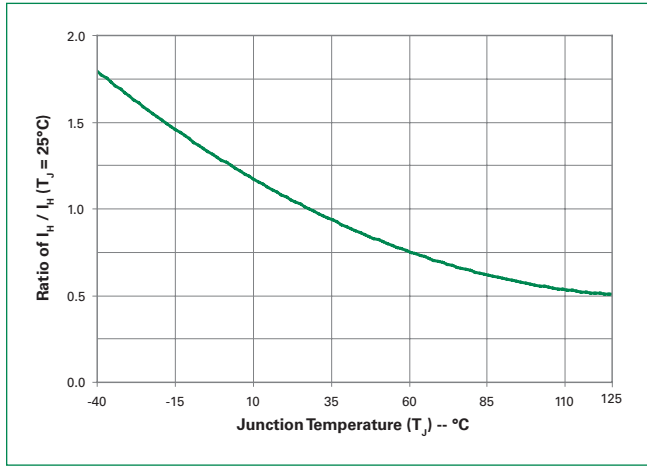

Figure 8: Maximum Allowable Case Temperature vs. RMS On-State Current

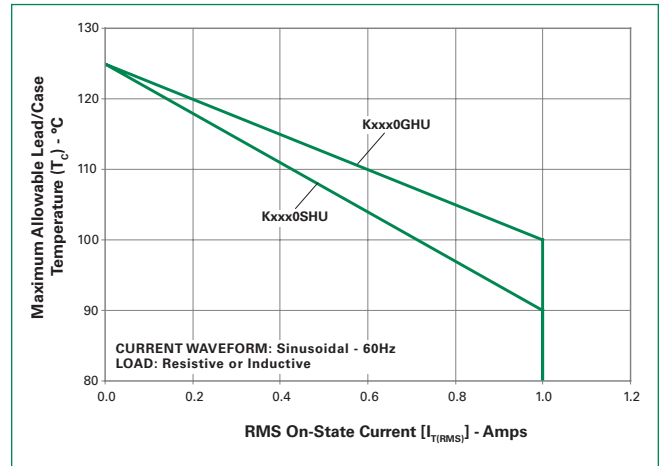

Figure 9: Maximum Allowable Ambient Temperature vs. RMS On-State Current

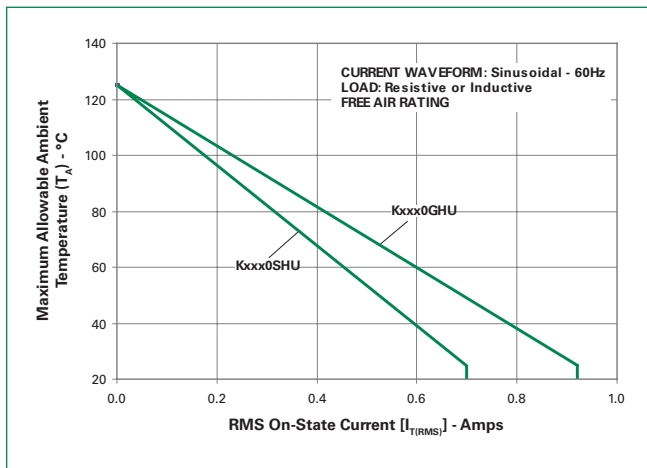

Figure 10: Normalized Repetitive Peak Breakover Current (I_{BO}) vs. Junction Temperature

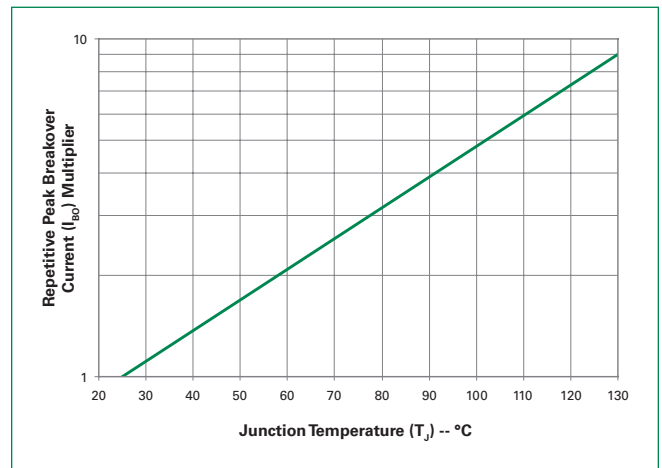
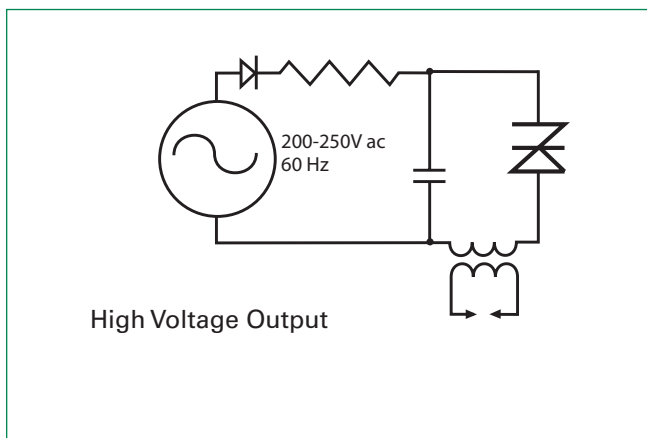
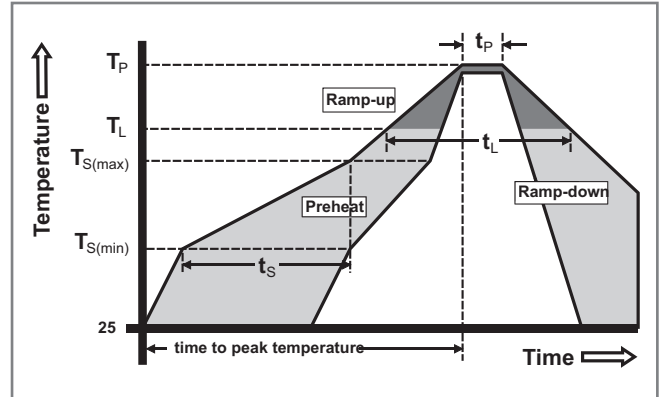

Figure 11: General Gas Ignitor Circuit



Soldering Parameters

Reflow Condition		Pb – Free assembly
Pre Heat	- Temperature Min ($T_{s(min)}$)	150°C
	- Temperature Max ($T_{s(max)}$)	200°C
	- Time (min to max) (t_s)	60 – 180 secs
Average ramp up rate (Liquidus Temp (T_L) to peak)		5°C/second max
$T_{s(max)}$ to T_L - Ramp-up Rate		5°C/second max
Reflow	- Temperature (T_L) (Liquidus)	217°C
	- Temperature (t_L)	60 – 150 seconds
Peak Temperature (T_p)		260 ^{+0/-5} °C
Time within 5°C of actual peak Temperature (t_p)		20 – 40 seconds
Ramp-down Rate		5°C/second max
Time 25°C to peak Temperature (T_p)		8 minutes Max.
Do not exceed		280°C



Physical Specifications

Terminal Material	Copper Alloy
Terminal Finish	100% Matte Tin-plated
Body Material	UL recognized epoxy meeting flammability classification 94V-0.

Design Considerations

Careful selection of the correct device for the application's operating parameters and environment will go a long way toward extending the operating life of the Thyristor. Overheating and surge currents are the main killers of SIDACs. Correct mounting, soldering, and forming of the leads also help protect against component damage.

Reliability/Environmental Tests

Test	Specifications and Conditions
High Temperature Voltage Blocking	MIL-STD-750: Method 1040, Condition A Rated V_{DRM} (VAC-peak), 125°C, 1008 hours
Temperature Cycling	MIL-STD-750: Method 1051 -40°C to 150°C, 15-minute dwell, 100 cycles
Biased Temperature & Humidity	EIA/JEDEC: JESD22-A101 (VDC), 85°C, 85%RH, 1008 hours
High Temp Storage	MIL-STD-750: Method 1031 150°C, 1008 hours
Low-Temp Storage	-40°C, 1008 hours
Thermal Shock	MIL-STD-750: Method 1056 0°C to 100°C, 5-minute dwell, 10-second transfer, 10 cycles
Autoclave (Pressure Cooker Test)	EIA/JEDEC: JESD22-A102 121°C, 100%RH, 2atm, 168 hours
Resistance to Solder Heat	MIL-STD-750: Method 2031 260°C, 10 seconds
Solderability	ANSI/J-STD-002: Category 3
Repetitive Surge Life Testing	MIL-STD-750: Method 2036, Condition E

Dimensions — DO-15

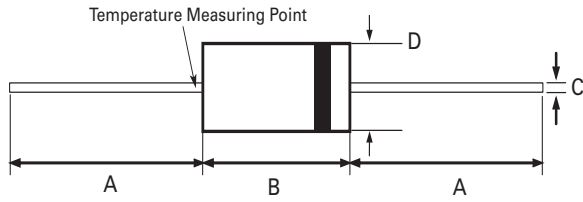

Dimension	Inches		Millimeters	
	Max	Max	Min	Max
A	1.000	-	25.40	-
B	0.230	0.300	5.80	7.60
C	0.028	0.034	0.71	0.86
D	0.104	0.140	2.60	3.60

Dimensions — DO-214AA

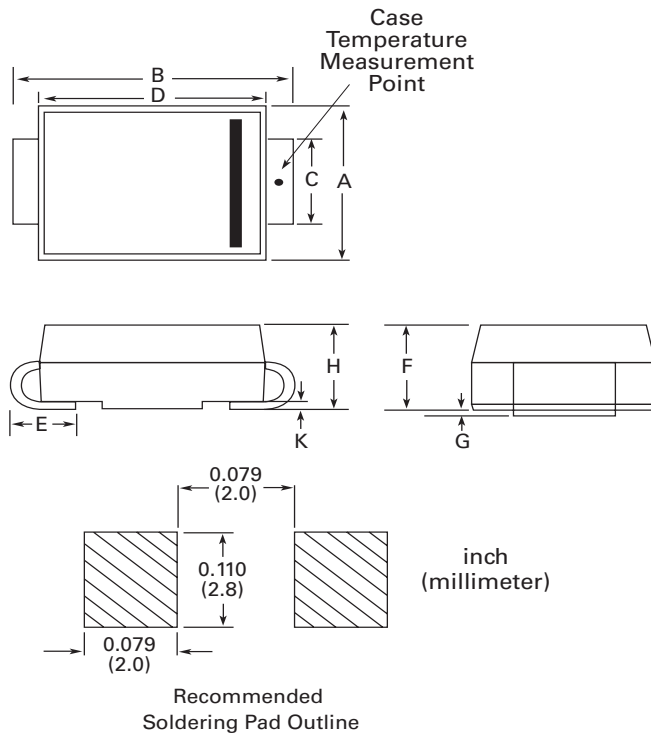

Dimension	Inches		Millimeters	
	Max	Max	Min	Max
A	0.130	0.156	3.30	3.95
B	0.201	0.220	5.10	5.60
C	0.077	0.087	1.95	2.20
D	0.159	0.181	4.05	4.60
E	0.030	0.063	0.75	1.60
F	0.075	0.096	1.90	2.45
G	0.002	0.008	0.05	0.20
H	0.077	0.104	1.95	2.65
K	0.006	0.016	0.15	0.41

Product Selector

Part Number	Switching Voltage Range		Blocking Voltage	Packages	
	V _{BO} Minimum	V _{BO} Maximum	V _{DRM}	DO-15	DO-214AA
K2000yHU	190V	210V	180V	K2000GHU	K2000SHU
K2200yHU	210V	230V	190V	K2200GHU	K2200SHU
K2400yHU	230V	250V	210V	K2400GHU	K2400SHU
K2500yHU	240V	260V	220V	K2500GHU	K2500SHU

Note: y = package

Packing Options

Part Number	Marking	Weight	Packaging Mode	Base Quantity
K2xx0GHU	K2xx0GHU	0.38g	Bulk	1000
K2xx0GHURP	K2xx0GHU	0.38g	Reel Pack	5000
K2xx0SHURP	KxxHU	0.10g	Reel Pack	2500

Note: xx = voltage

DO-15 Reel Pack (RP) Specifications

Meets all EIA RS-296 Standards

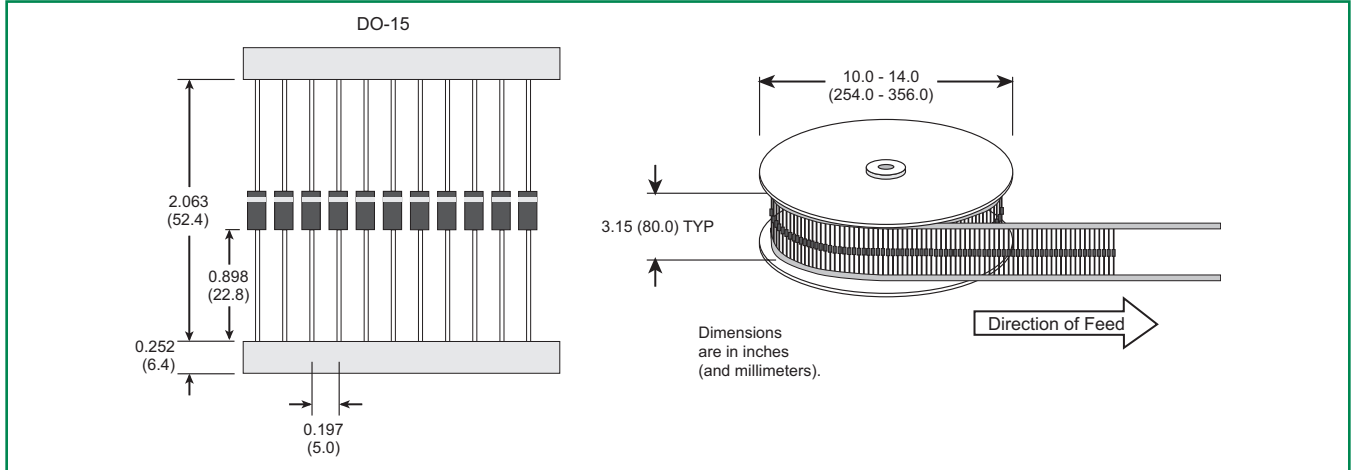

DO-214AA Embossed Carrier Reel Pack (RP) Specifications

Meets all EIA-481-1 Standards

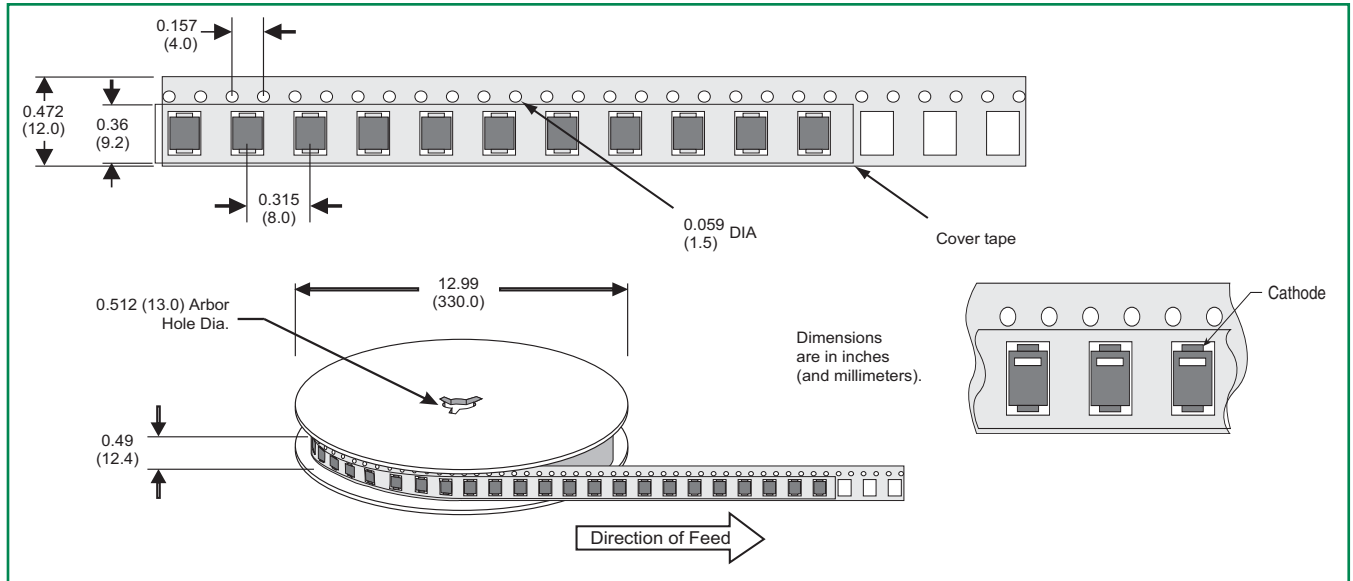

Part Numbering System

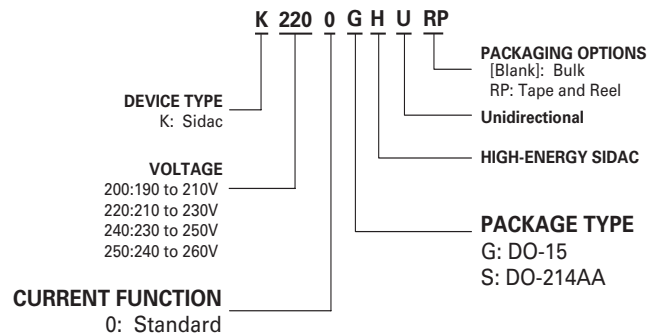

Part Marking System

