

Micro Relay K (THT – THR)

- Small power relay
- Limiting continuous current 20A at 85°C
- Low weight
- Low noise operation
- Wave (THT) and reflow (THR/pin-in-paste) solderable versions
- For double version refer to Double Micro Relay K

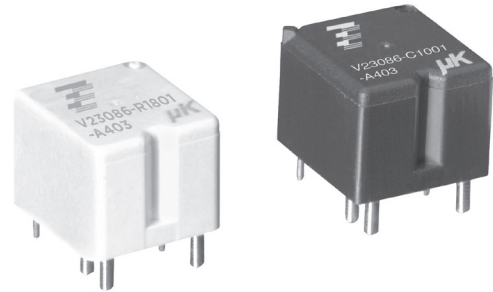

086C/R1_fw1b

Typical applications

Door lock, heated front/rear screen, lamps front/rear/fog light, interior lights, seat control, sun roof, window lifter, wiper control.

Contact Data

Typical applications	Inductive load V23086-*1*01-A403	Wiper load V23086-*1*02-A803	Resistive/inductive load V23086-*1*01-A402	Lamp load V23086-*1*51-A502
Contact arrangement	1 form C, 1 CO	1 form C, 1 CO	1 form A, 1 NO	1 form A, 1 NO
Rated voltage	12VDC	10VDC	12VDC	10VDC
Rated current ¹⁾	NO/NC 30/25A	NO/NC 30/25A	30A	15A
Limiting continuous current ¹⁾				
23°C	30/25A	30/25A	30A	15A
85°C	20/15A	20/15A	20A	10A
105°C	15/10A	15/10A	15A	
Limiting making current	40A ²⁾	40A ²⁾	40A ²⁾	100A ³⁾
Limiting breaking current	30A	30A	30A	30A
Contact material		AgSnO ₂		
Min. contact load		>1A at 5VDC ⁴⁾		
Initial voltage drop at 10A, typ./max.		30/300mV		
Operate/release time		typ. 3/1.5ms ⁵⁾		
Electrical endurance				
cyclic temperature -40°C, +25°C, +85°C				
form C contact (CO) at 14VDC	motor reverse blocked, 25A, 0.77mH >1x10 ⁵ ops.	wiper, 25A make/5A break, generator peak, 20A on NC, 1mH >1x10 ⁶ ops.	resistive 20A >1x10 ⁵ ops.	lamp 100A inrush, 10A steady state >1x10 ⁵ ops.
form A contact (NO) at 14VDC				
Mechanical endurance		>5x10 ⁶ ops.		

Max. DC load breaking capacity

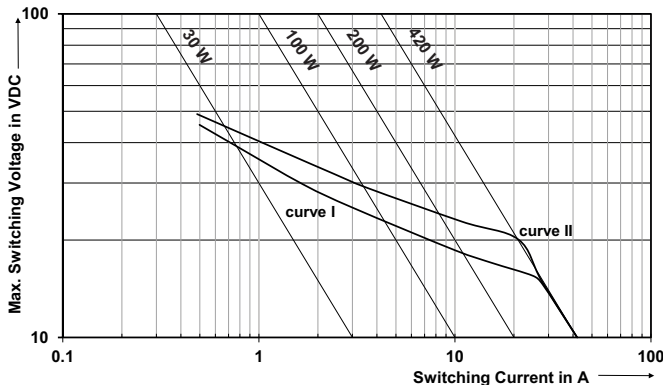

Load limit curve 1: arc extinguishes, during transit time (changeover contact).
Load limit curve 2: safe shutdown, no stationary arc (make contact).
Load limit curves measured with low inductive resistors verified for 1000 switching events.

- 1) Measured on 70x70x1.5mm epoxy PCB FR4 with 25cm² (double layer 105µm) copper area. Connecting cable cross section 6 mm². Boundary conditions: 180°C coil temperature; 130°C solder joint.
- 2) The values apply to a resistive or inductive load with suitable spark suppression and at maximum 13.5VDC for 12VDC load voltages. For a load current duration of maximum 3s for a make/break ratio of 1:10.
- 3) Corresponds to the peak inrush current on initial actuation (cold filament).
- 4) See chapter Diagnostics of Relays in our Application Notes or consult the internet at <http://relays.te.com/appnotes/>
- 5) Measured at nominal voltage without coil suppression unit. A low resistive suppression device in parallel to the relay coil increases the release time and reduces the lifetime caused by increased erosion and/or higher risk of contact tack welding.

Micro Relay K (THT – THR) (Continued)

Coil Data

Rated coil voltage	12VDC
--------------------	-------

Coil versions, DC coil

Coil code	Rated voltage VDC	Operate voltage VDC	Release voltage VDC	Coil resistance $\Omega \pm 10\%$	Rated coil power mW
001/801	12	6.9	1.5	254	567
002/802	10	5.7	1.25	181	552
051/851	10	6.5	1.1	90	1111

All figures are given for coil without pre-energization, at ambient temperature +23°C.

Coil operating range

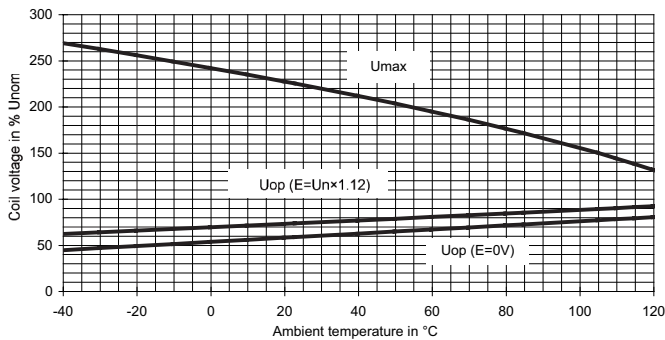

Does not take into account the temperature rise due to the contact current
E = pre-energization

Insulation Data

Initial dielectric strength	
between open contacts	500VAC _{rms}
between contact and coil	500VAC _{rms}

Other Data

EU RoHS/ELV compliance	compliant
Ambient temperature, DC coil	-40 to +105°C
Cold storage, IEC 60068-2-1	1000h; -40°C
Dry heat, IEC 60068-2-2	1000h; +125°C
Climatic cycling with condensation, EN ISO 6988	20 cycles, storage 8/16h
Temperature cycling (shock), IEC 60068-2-14, Na	100 cycles; -40/+125°C
Temperature cycling, IEC 60068-2-14, Nb	35 cycles; -40/+125°C
Damp heat cyclic, IEC 60068-2-30, Db, variant 1	6 cycles 25°C/55°C/93%RH
Damp heat constant, IEC 60068-2-3 method Ca	56 days 40°C/95%RH
Degree of protection	
THT:	RT III (61810)
THR:	RT II (61810)
Sealing test, IEC 60068-2-17: THT	Qc, method 2, 1min, 70°C
Corrosive gas	
IEC 60068-2-42	10 days
IEC 60068-2-43	10 days
Vibration resistance (functional)	
IEC 60068-2-6 (sine sweep)	10 to 500Hz; 6g ⁶⁾
Shock resistance (functional)	
IEC 60068-2-27 (half sine)	6ms, up to 30g ⁶⁾
Terminal type	PCB:THT, THR
Weight	approx. 4g (0.14oz)
Solderability (aging 3: 4h/155°C) THT	
IEC 60068-2-20	Ta, method 1, hot dip 5s, 215°C
Solderability THR	
IEC60068-2-58	hot dip 5s 245°C
Resistance to soldering heat THT	
IEC 60068-2-20	Tb, method 1A, hot dip 10s, 260°C with thermal screen
Resistance to soldering heat THR	
IEC 60068-2-58	260°C; preheating min 130°C
Storage conditions	according IEC 60068-1 ⁷⁾
Packaging unit	2000 pcs.

6) Depending on mounting position: no change in the switching state >10µs.

7) For general storage and processing recommendations please refer to our Application Notes and especially to Storage in the Definitions or at <http://relays.te.com/appnotes/>

Micro Relay K (THT – THR) (Continued)

Terminal Assignment

Bottom view on solder pins

1 form A, 1 NO

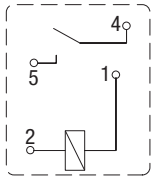

86ets_ab

1 form C, 1 CO

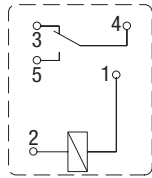

86etw_ab

Dimensions

Micro Relay K, THT version

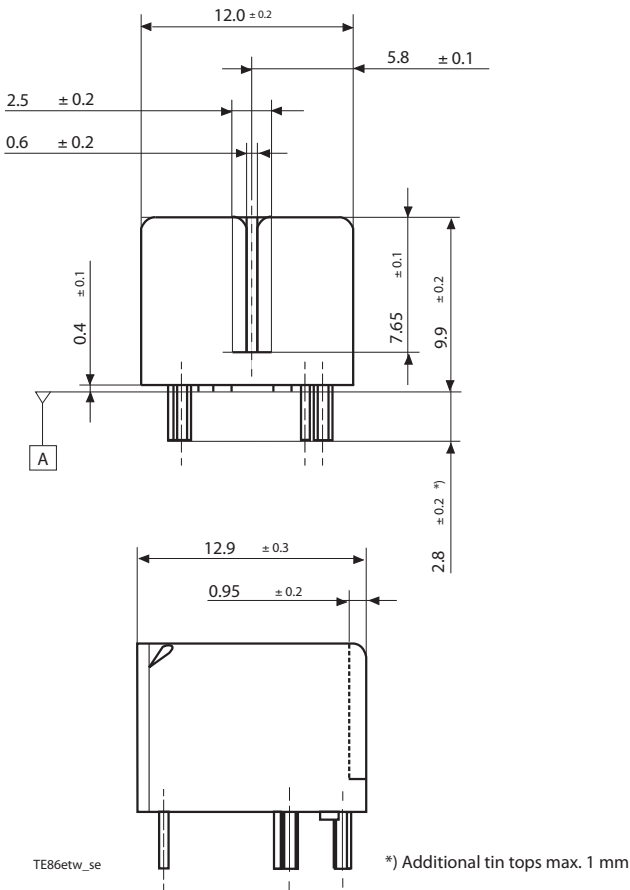

TE86etw_se

*) Additional tin tops max. 1 mm

Mounting Hole Layout

Bottom view on solder pins

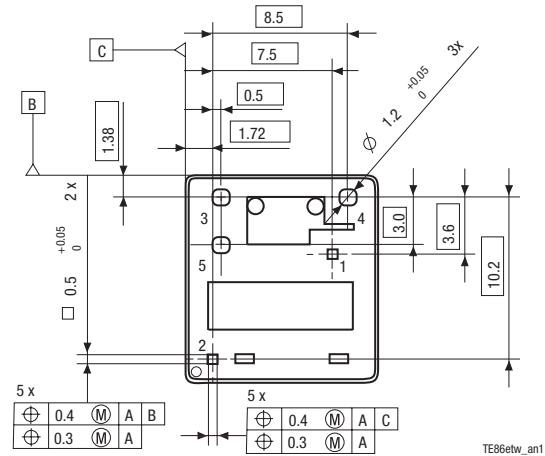

TE86etw_an1

Remark: Positional tolerances according to DIN EN ISO 5458

Micro Relay K (THT – THR) (Continued)

Micro Relay K, THR version

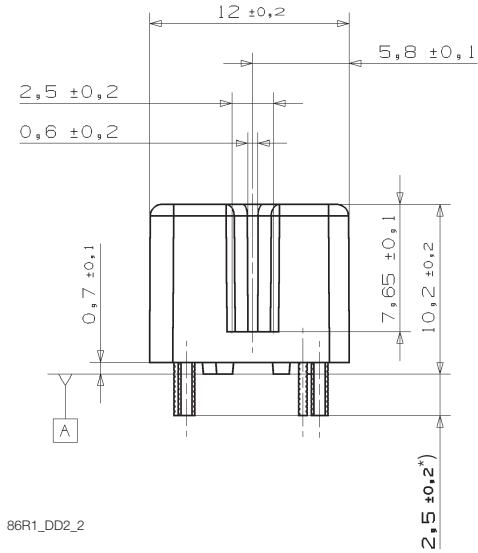

Mounting Hole Layout
Bottom view on solder pins

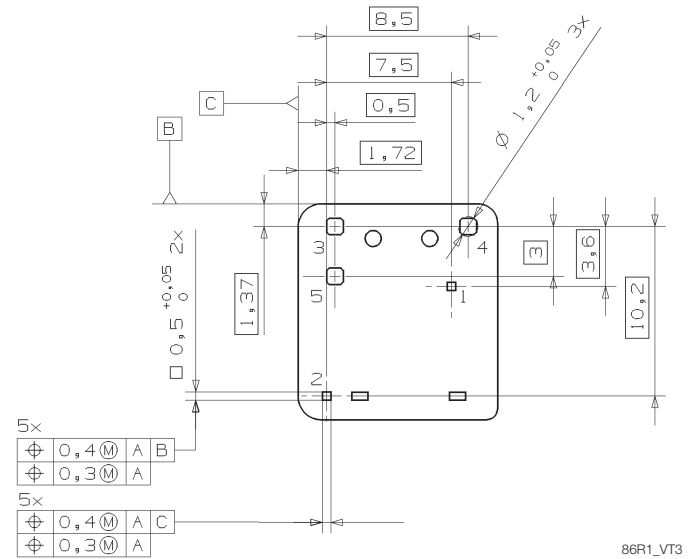

View of Stand-Offs
Bottom view on solder pins

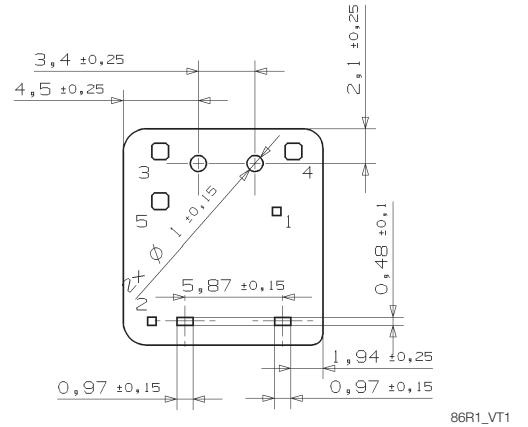
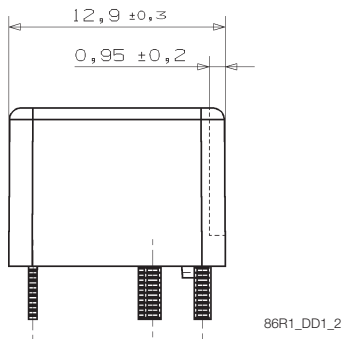

*) Additional tin tops max. 1mm

Micro Relay K (THT – THR) (Continued)

Product code structure		Typical product code		V23086	-C	1	001	-A	4	03
Type										
V23086 Micro Relay K (THT – THR)										
Terminal and enclosure										
C		PCB version THT, sealed		R		PCB version THR, vented				
Design										
1		Single relay								
Coil										
001		Standard (THT)		002		Sensitive (THT)				
801		Standard (THR)		802		Sensitive (THR)				
051		Lamp load (THT)		851		Lamp load (THR)				
Contact type										
A		Single contact								
Contact material index										
4		AgSnO ₂ standard		8		AgSnO ₂ wiper load				
5		AgSnO ₂ lamp load								
Contact arrangement index										
02		NO		03		CO				

Product code	Version	Design	Coil	Contact	Cont. material	Arrangement	Part number
V23086-C1001-A402	PCB THT,	Single	Standard	Single	AgSnO ₂ (standard)	1 form A, 1 NO	0-1393280-5
V23086-C1001-A403	cleanable					1 form C, 1 CO	0-1393280-6
V23086-C1051-A502			Lamp load		AgSnO ₂ (lamp)	1 form A, 1 NO	2-1904093-1
V23086-C1002-A803			Sensitive		AgSnO ₂ (wiper)	1 form C, 1 CO	2-1414987-3
V23086-R1801-A402	PCB THR,		Standard		AgSnO ₂ (standard)	1 form A, 1 NO	2-1904093-2
V23086-R1801-A403	vented					1 form C, 1 CO	6-1414920-0
V23086-R1851-A502			Lamp load		AgSnO ₂ (lamp)	1 form A, 1 NO	9-1904064-4
V23086-R1802-A803			Sensitive		AgSnO ₂ (wiper)	1 form C, 1 CO	7-1414967-8

This list represents the most common types and does not show all variants covered by this datasheet. Other types on request.