

**Advance Information**

December 1992

**DESCRIPTION**

The SSI 32R1220/1221/1222 are bipolar monolithic integrated circuits designed for use with center-tapped ferrite or MIG recording heads. They provide a low noise read path, write current control, and data protection circuitry for as many as 4 channels. Power supply fault protection is provided by disabling the write current generator during power sequencing. A power down mode (idle) is provided to reduce power consumption to less than 10 mW. The SSI 32R1221 option provides write current boost feature which can be selected without using additional external resistors.

The SSI 32R1222 option provides a bond option compatible with other available three-terminal Read/Write devices.

**FEATURES**

- **+5V ( $\pm 10\%$ ) only power supply**
- **Low power**
  - Pd = 150 mW Read mode (NOM)
  - Pd  $\leq 5$  mW Idle mode (NOM)
- **High Performance**
  - Read mode gain = 250 V/V
  - Input noise = 0.9 nV/ $\sqrt{\text{Hz}}$  max.
  - Input capacitance = 19 pF max.
  - Write current range = 10 - 30 mA
  - Head voltage swing = 6.0 Vpk Nom
- **Designed for center-tapped ferrite or MIG heads**
- **TTL selectable write current boost**
- **Pin compatible with 32R1200**
- **Power supply fault protection**
- **Write unsafe detection**
- **Enhanced Write to Read recovery**

**BLOCK DIAGRAM**

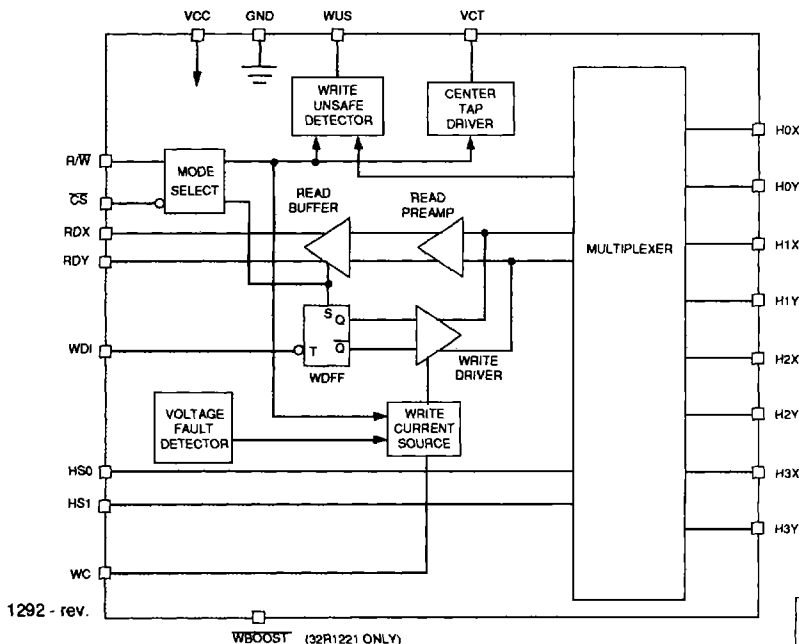

**PIN DIAGRAM**

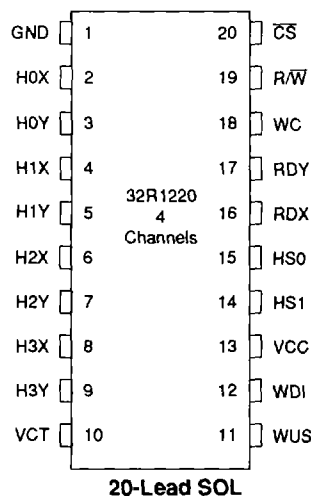

CAUTION: Use handling procedures necessary for a static sensitive component.

# SSI 32R1220/1221/1222

## +5V, 2, 4-Channel Ferrite/MIG

### Read/Write Device

#### DESCRIPTION

##### WRITE MODE

A source of recording current is provided to the head center tap by an internal voltage reference, VCT. The current is conducted through the head alternately into an HnX terminal or an HnY terminal according to the state of an internal flip-flop. The flip-flop is triggered by the negative transition of the Write Data Input line (WDI). A proceeding Read mode selection initializes the write data flip-flop, Wdff, to pass write current through the "X" side of the head. The write current magnitude is determined by the value of an external resistor Rwc connected between WC terminal and GND, and is given by:

$$I_w = K/R_{wc}, \text{ where } K = \text{Write Current Constant}$$

In addition this current can be given a 33% boost, without switching in additional resistance values, by pulling  $\overline{WBOOST}$  low (32R1221/1221R only).

##### WRITE MODE FAULT DETECT CIRCUIT

Several circuits are dedicated to detecting fault conditions associated with the Write mode. A logical high level will be present at the Write Unsafe (WUS) terminal if any of the following write fault conditions are present:

- Head open
- Head center tap open
- Head shorted
- Head shorted to ground
- No write current
- WDI frequency too low
- Device in Read or Idle mode

The Write Unsafe output is open-collector and is usually terminated by an external resistor connected to VCC. Two negative transitions on WDI, after the fault is corrected, will clear the WUS flag.

Additionally, a power voltage monitoring circuit is used to detect VCC voltage level. If it is too low to permit valid data recording, write current is inhibited. With VCC voltage level above the inhibiting value, control of write current is provided by the mode selection inputs.

##### READ MODE

In Read Mode, ( $R/\overline{W}$  high and  $\overline{CS}$  low), the circuit functions as a low noise differential amplifier. The read amplifier input terminals are determined by the Head Select inputs. The read amplifier outputs (RDX, RDY) are emitter follower sources, providing low impedance outputs. The amplifier gain polarity is non-inverting between HnX, HnY inputs and RDX, RDY outputs.

##### IDLE MODE

Taking  $\overline{CS}$  high selects the Idle mode which switches the RDX and RDY outputs into a high impedance state and deactivates the device. Power consumption in this mode is held to a minimum.

##### MODE SELECTION AND INDICATION CIRCUIT

Logical control inputs which select mode and head channel are TTL compatible. Their functions are described in Table 1 and Table 2.

TABLE 1: Head Select Table

Head Selected	HS1	HS0
0	0	0
1	0	1
2	1	0
3	1	1

TABLE 2: Mode Select Table

Mode Select		Selected Mode	Indicating & Fault Outputs
$\overline{CS}$	R/ $\overline{W}$		
1	X	Idle	off
0	1	Read	off
0	0	Write	on*

\* Provided that no fault is detected.

**SSI 32R1220/1221/1222**  
**+5V, 2, 4-Channel Ferrite/MIG**  
**Read/Write Device**

**PIN DESCRIPTION**

NAME	I/O	DESCRIPTION
HS0-HS1	I	Head Select. Logical combinations select one of four Heads. See Table 1.
$\overline{CS}$	I	Chip Select: a low level enables device. Has internal pull-up resistor.
$R/\overline{W}$	I	Read/Write: a high level selects Read mode. Has internal pull-up resistor.
WUS	O*	Write Unsafe: a high level indicates an unsafe writing condition.
WDI	I	Write Data In: negative transition toggles direction of head current.
H0X-H3X H0Y-H3Y	I/O	X, Y head connections.
RDX, RDY	O*	X, Y Read Data: differential read signal output.
WC	-	Write Current: used to set the magnitude of the write current.
VCT	-	Voltage Center Tap: voltage source for head center tap.
VCC	-	+5V
GND	-	Ground
WBOOST**	I	A logic low signal on this pin increases the write current magnitude by typically 33%.

\* When more than one R/W device is used, these signals can be wire OR'ed.

\*\* 32R1221 only.

**ELECTRICAL SPECIFICATIONS**

**ABSOLUTE MAXIMUM RATINGS**

(All voltages referenced to GND. Currents into device are positive.)

PARAMETER		VALUE	UNITS
DC Supply Voltage	VCC	-0.3 to +6	VDC
Digital Input Voltage Range	HS1, HS0, WDI, $R/\overline{W}$ , $\overline{CS}$ , WBOOST	-0.3 to VCC + 0.3	VDC
Head Port Voltage Range	VH	-0.3 to VCC + 0.3	VDC
Write Current Pin Voltage	Vwc	-0.3 to VCC + 0.3	VDC
WUS Pin Voltage Range	Vwus	-0.3 to +6.0	VDC
Write Current Zero-Peak	IW	60	mA
RDX, RDY Output Current	Io	-10	mA
RDX, RDY Pin Voltage		VCC + 0.3	VDC
VCT Output Current Range	Ivct	-60	mA
WUS Output Current Range	Iwus	+12	mA
Storage Temperature Range	Tstg	-65 to 150	°C
Package Temperature (20 sec Reflow)		215	°C

# SSI 32R1220/1221/1222

## +5V, 2, 4-Channel Ferrite/MIG

### Read/Write Device

#### RECOMMENDED OPERATION CONDITIONS

PARAMETER	CONDITIONS	MIN	NOM	MAX	UNITS
DC Supply Voltage	VCC	4.5	5.0	5.5	VDC
Head Inductance	Lh	1		10	$\mu$ H
Damping Resistor	Rd	350		2000	$\Omega$
Write Current Range	IW	10		30	mA
Iw • Lh Range		20		200	mA • $\mu$ H
Junction Temperature Range	Tj	+25		+125	$^{\circ}$ C
Operating Temperature Range	Ta	0		70	$^{\circ}$ C

#### DC CHARACTERISTICS

(Unless otherwise specified, recommended operating conditions apply.)

#### POWER SUPPLY

PARAMETER	CONDITIONS	MIN	NOM	MAX	UNITS
VCC Supply Current (ICC)	Read Mode		30	40	mA
	Idle Mode		1.0	1.8	mA
	Write Mode		15 + Iw	25 + Iw	mA
Power Dissipation	Read Mode		150	220	mW
	Idle Mode		5	10	mW
	Write Mode		75 + 5 Iw	140 + 5 Iw	mW

#### DIGITAL I/O

PARAMETER	CONDITIONS	MIN	NOM	MAX	UNITS
VIL Input Low Voltage CS, R/W WDI, HS0, HS1				0.8	VDC
VIH Input High Voltage CS, R/W WDI, HS0, HS1		2.0			VDC
IIL Input Low Current CS, R/W WDI, HS0, HS1	VIL = 0.4V	-0.1			mA
IIH Input High Current CS, R/W WDI, HS0, HS1	VIH = 2.7V			20	$\mu$ A
VOL WUS Output Low Voltage	IOL = 4.0 mA			0.5	VDC
IOH WUS Output High Current	VOH = 5.0V			100	$\mu$ A

# SSI 32R1220/1221/1222 +5V, 2, 4-Channel Ferrite/MIG Read/Write Device

1

## WRITE MODE

PARAMETER	CONDITIONS	MIN	NOM	MAX	UNITS
Center Tap Voltage VCT	Write Mode		$V_{CC} - 0.9$		VDC
Head Current (per side)	Write Mode, $0 \leq V_{CC} \leq 3.75V$	-200		200	$\mu A$
Write Current Range	$750 \text{ k}\Omega \leq R_{wc} \leq 3 \text{ k}\Omega$	10		30	mA
Write Current Constant "K"		27.6	30	32.4	
I <sub>wc</sub> to Head Current Gain			20		mA/mA
Write Current Boost Factor *	WBOOST = Low	1.28	1.33	1.38	mA/mA
Unselected Head Leakage Current	DC Current			85	$\mu A$
RDX, RDY Leakage	RDX, RDY = 4V Idle Mode	-100		100	$\mu A$
WDI Pulse Width (see Figure 1)	$V_{il} \geq 0.2V$ PWH	15			ns
	PWL	5			ns

\* 32R1221 only

## READ MODE

PARAMETER	CONDITIONS	MIN	NOM	MAX	UNITS
Center Tap Voltage	Read Mode		$V_{CC} - 2.6$		VDC
Input Bias Current (Differential)			50	120	$\mu A$
Output Offset Voltage	Read Mode	-400		+400	mV
Common Mode Output Voltage	Read Mode	2	$V_{CC} - 2.3$	3.5	VDC

## FAULT DETECTION CHARACTERISTICS

Unless otherwise specified recommended conditions apply, I<sub>w</sub> = 15 mA, L<sub>h</sub> = 5  $\mu H$ , R<sub>d</sub> = 750 $\Omega$ .  
F(WDI) = 10 MHz.

PARAMETER	CONDITIONS	MIN	NOM	MAX	UNITS
Minimum Rate of WDI Input for Safe condition		1.25			MHz
Maximum Rate of WDI Input for Unsafe condition				250	kHz
Minimum voltage value for guaranteed write current turn-on		4.25			VDC
Maximum voltage value for guaranteed write current turn-off				3.75	VDC

# SSI 32R1220/1221/1222

## +5V, 2, 4-Channel Ferrite/MIG

### Read/Write Device

#### DYNAMIC CHARACTERISTICS AND TIMING

(Unless otherwise specified, recommended operating conditions apply and  $I_w = 15 \text{ mA}$ ,  $L_h = 5 \mu\text{H}$ ,  $R_d = 750 \Omega$ ,  $f(\text{WDI}) = 5 \text{ MHz}$ ,  $CL(\text{RDX, RDY}) \leq 20 \text{ pF}$ .)

#### WRITE MODE

PARAMETER	CONDITIONS	MIN	NOM	MAX	UNITS
Differential Head Voltage Swing		5.0	6.0		V(pk)
Unselected Head Transient Current	$1 \mu\text{H} \leq L_h \leq 9.5 \mu\text{H}$			2	mA(pk)
Differential Output Capacitance				15	pF
Differential Output Resistance	32R1220/1221/1222	10			k $\Omega$
	32R1220R/1221R/1222R	600		960	$\Omega$

#### READ MODE

Differential Voltage Gain	$V_{in} = 1 \text{ mV RMS}$	200	250	300	V/V
Bandwidth (-3dB)	$ Z_s  < 5 \Omega$ , $V_{in} = 1 \text{ mVpp}$	30	50		MHz
Input Noise Voltage	BW = 15 MHz, $L_h = 0$ , $R_h = 0$		0.65	0.9	nV/ $\sqrt{\text{Hz}}$
Differential Input Capacitance			15	19	pF
Differential Input Resistance		1.2	2.5		k $\Omega$
Common Mode Rejection Ratio	$V_{cm} = 100 \text{ mVpp@1 MHz}$ $< f < 10 \text{ MHz}$	50			dB
Power Supply Rejection Ratio	$V_{cs} = 100 \text{ mVpp@1 MHz}$ $< f < 10 \text{ MHz}$	45			dB
Channel Separation	Unselected Channels: $V_{in} = 20 \text{ mVpp 1 MHz}$ $< f < 10 \text{ MHz}$	50			dB
Single Ended Output Resistance			25	50	$\Omega$
Output Current	AC Coupled Load, RDX to RDY	1.0	1.5		mA

**DYNAMIC CHARACTERISTICS AND TIMING** (continued)

**SWITCHING CHARACTERISTICS**

PARAMETER	CONDITIONS	MIN	NOM	MAX	UNITS
R/W	Read to Write			1.0	$\mu$ s
	Write to Read			1.0	$\mu$ s
$\overline{CS}$	Unselect to Select			1.0	$\mu$ s
	Select to Unselect			0.6	$\mu$ s
HS0, 1 to any Head	To 90% of 100 mV. 10 MHz Read signal envelope			0.6	$\mu$ s
WUS:	Safe to Unsafe (TD1)	1.6	4	8	$\mu$ s
	Unsafe to Safe (TD2)			1.0	$\mu$ s
Head Current	From 50% Points, Lh = 0 Rh = 0				
	Prop. Delay - TD3		15	30	ns
	Asymmetry			2	ns
	Rise/Fall Time	10% - 90% Points			20

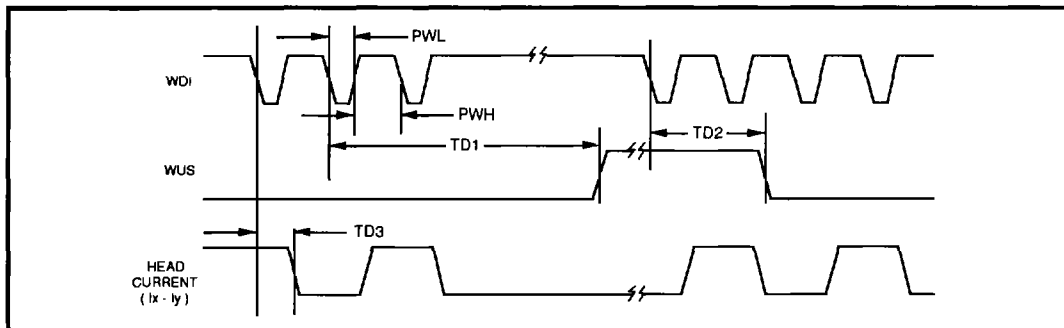

FIGURE 1: Write Mode Timing Diagram

# SSI 32R1220/1221/1222

## +5V, 2, 4-Channel Ferrite/MIG

### Read/Write Device

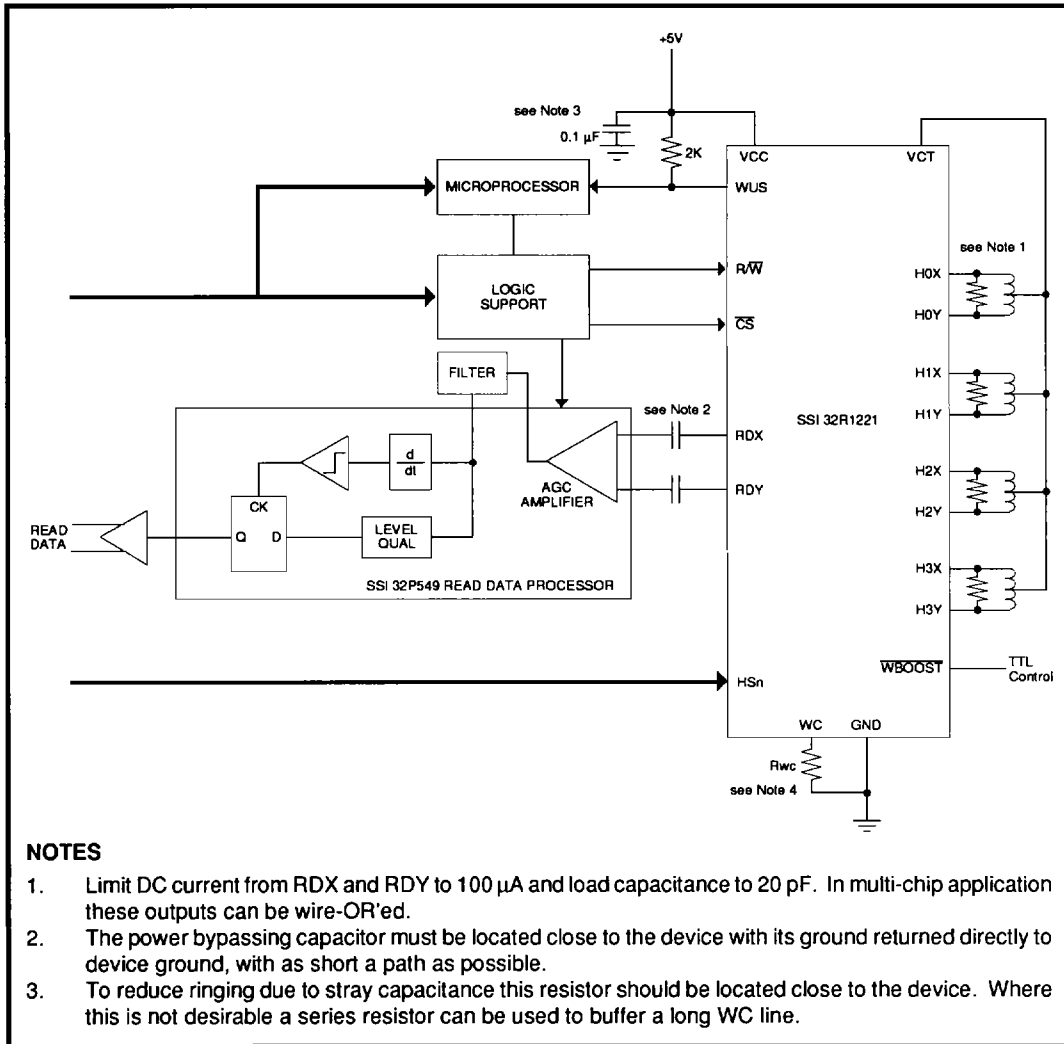
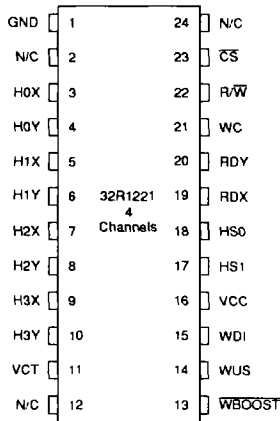

FIGURE 2: Applications Information

# SSI 32R1220/1221/1222 +5V, 2, 4-Channel Ferrite/MIG Read/Write Device

## PACKAGE PIN DESIGNATIONS

(Top View)



**24-Lead SOL, SOV**

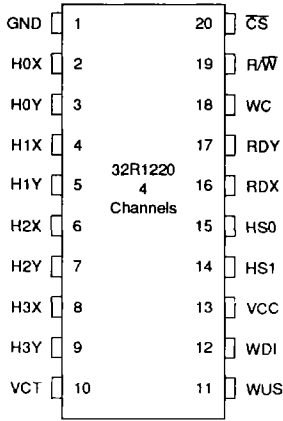

**20-Lead SOL, SOV**

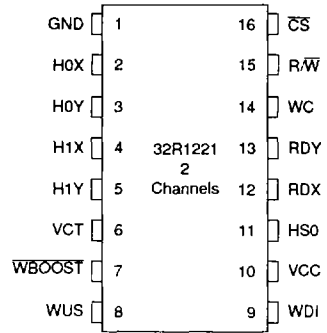

**16-Lead SOL, SON**

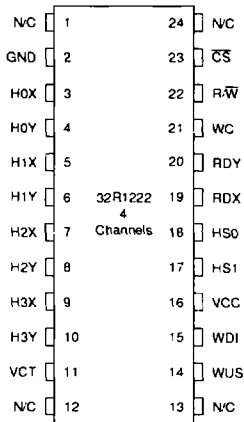

**24-Lead SOV**

**Advance Information:** Indicates a product still in the design cycle, and any specifications are based on design goals only. Do not use for final design.

No responsibility is assumed by Silicon Systems for use of this product nor for any infringements of patents and trademarks or other rights of third parties resulting from its use. No license is granted under any patents, patent rights or trademarks of Silicon Systems. Silicon Systems reserves the right to make changes in specifications at any time without notice. Accordingly, the reader is cautioned to verify that the data sheet is current before placing orders.

Silicon Systems, Inc., 14351 Myford Road, Tustin, CA 92680, (714) 573-6000, FAX: (714) 573-6914