

***THIS DOCUMENT IS FOR MAINTENANCE
PURPOSES ONLY AND IS NOT
RECOMMENDED FOR NEW DESIGNS***

SP973T8

30MHz 8-BIT FLASH ADC (TTL/CMOS OUTPUTS)

The SP973T8 is a wideband, full flash analog-to-digital converter that requires no preceding sample and hold. The device contains a full 8-bit D-type latch which ensures that the 8 TTL/CMOS outputs are accurately registered and have a good data valid time at high clock speeds.

Operating from a single +5 volt supply the device is capable of conversion rates well in excess of 30MHz and its wideband input allows signals with frequencies up to the Nyquist limit to be digitised with high accuracy. An internal bandgap voltage regulator gives low DC drift over a wide operating temperature range.

The SP973T8 is designed for applications where power consumption and package size is at a premium.

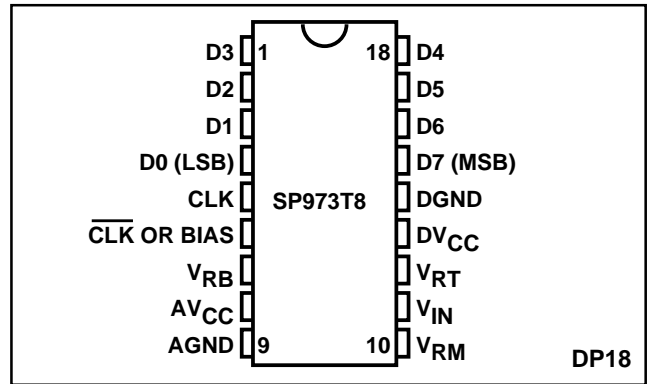

Fig.1 Pin connections - top view

FEATURES

- Flash Converter, No Sample and Hold Required
- Wideband Analog Input 70MHz, 3dB (Typ.)
- Low Power Consumption (600mW Typ.)
- Latched TTL/CMOS Compatible Outputs
- No Missing Codes - Guaranteed
- Designed for Wideband Operation
- Single 5V Supply
- Production Tested at 30MHz

APPLICATIONS

- Studio Quality Video
- DBS Broadcast Video
- High Resolution TV
- Nucleonics
- Radar
- Computing

ORDERING INFORMATION

SP973T8 C DP (Commercial - Plastic DIL package)

ABSOLUTE MAXIMUM RATINGS

Supply voltage, V_{CC}	7V
Output Current	10mA
Input Voltage, V_{IN}	V_{CC}
Operating Temperature	0°C to +70°C
Storage Temperature	-65°C to +150°C

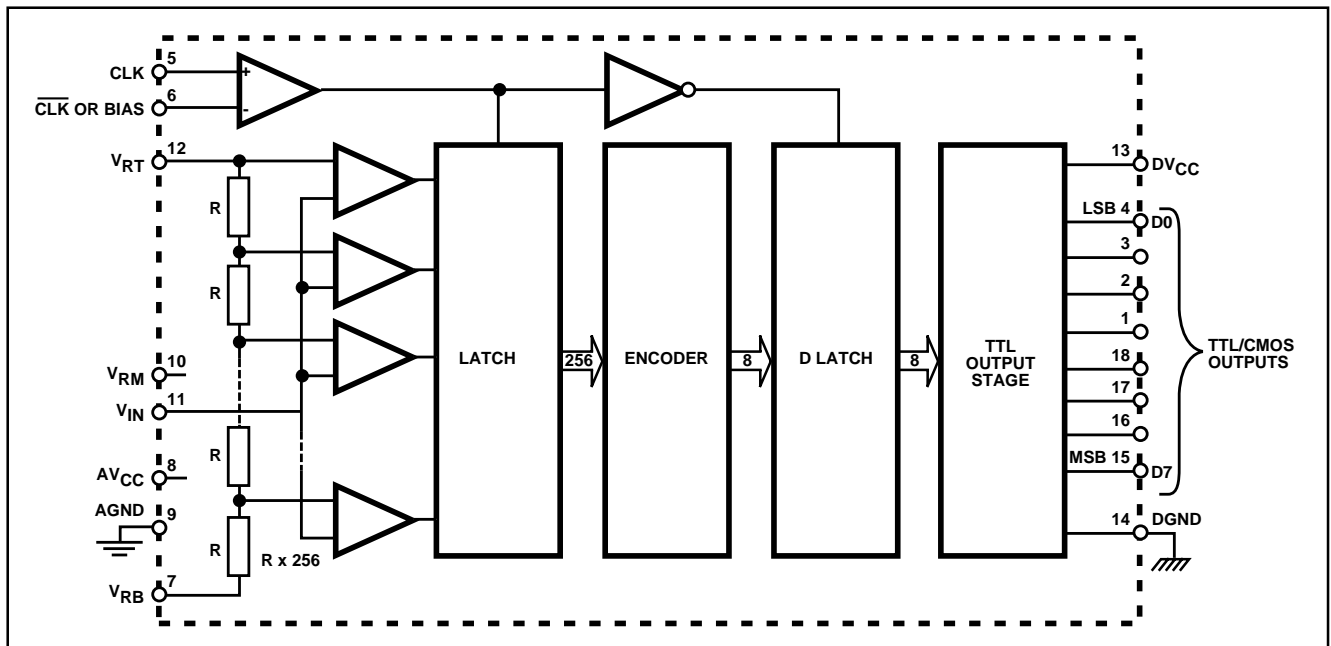

Fig.2 Internal block diagram

ELECTRICAL CHARACTERISTICS

These characteristics are guaranteed over the following conditions (unless otherwise stated):

T_{amb} = 25°C, V_{CC} = +5V ± 0.25V

Full temperature range = 0°C to +70°C

DC CHARACTERISTICS

Characteristic	Symbol	Temp.	Test level	Value			Units	Conditions
				Min.	Typ.	Max.		
Power Supply								
Supply current	I _{CC}	Full	4	100		140	mA	V _{IN} = V _{RT}
		25	1	110	120	130	mA	
Power dissipation	P _D	Full	4	475		735	mW	
		25	1	520	600	680	mW	
Analog Input								
Input range	V _{IN}	Full	4	1.8		V _{CC} -0.7	V	
Input bias current	I _{IN}	25	1	150	390	1100	µA	
3dB bandwidth	f _{3dB}	25	4		70		MHz	
Input capacitance	C _{IN}	25	4		30		pF	
Reference Ladder								
Ladder resistance	R _D	25	1	325	440	550	Ω	
Ladder voltage (top)	V _{RT}	Full	4		4.3	V _{CC} -0.7	V	
Ladder voltage (bottom)	V _{RB}	Full	4	1.8	2.3		V	
Ladder offset (top)	V _{RT0}	25	5		-4		mV	
Ladder offset (bottom)	V _{RB0}	25	5		+3		mV	
Ladder temp. coeff.	R _{TC}	Full	5		1.5		Ω/°C	
Clock Input								
Logic '1' voltage	V _{IH}	Full	4	2.75	4.3	V _{CC}	V	} A swing of 1V centred on the voltage applied to the <u>CLK</u> pin
Logic '1' current	I _{IH}	25	1			25	µA	
Logic '0' voltage	V _{IL}	Full	4	1.75	3.3	V _{CC} -1.0	V	
Logic '0' current	I _{IL}	25	1			2	µA	
Digital Outputs								
Logic '1' voltage	V _{OH}	Full	4	3.3			V	} Into Standard LS TTL Load
		25	1	3.5	3.8		V	
Logic '0' voltage	V _{OL}	Full	4			0.4	V	
		25	1		0.1	0.4	V	
Static performance								
Differential non-linearity	DNL	Full	4			±1	LSB	
		25	4			±0.5	LSB	
Integral non-linearity	INL	Full	4			±1	LSB	
		25	4			±1	LSB	

AC CHARACTERISTICS (Refer to Fig.7)

Characteristic	Symbol	Temp.	Test level	Value			Units	Conditions
				Min.	Typ.	Max.		
Clock min. high	t _{PW1}	25	4	10			ns	A _{IN} = 15MHz at FS
Clock min. low	t _{PW0}	25	4	10			ns	
Max. conversion rate		Full	4	30	50		MHz	
Aperture delay	t _{AD}	25	5		3		ns	
Output data delay	t _D	25	4		7		ns	
Output rise time	t _R	25	4		6		ns	
output fall time	t _F	25	4		8		ns	
Dynamic Performance								With F _{CLK} = 30MHz A _{IN} MAX = 10MHz at FS A _{IN} MAX = 10MHz at FS A _{IN} MAX = 1MHz at FS A _{IN} MAX = 5MHz at FS A _{IN} MAX = 10MHz at FS A _{IN} MAX = 1MHz at FS A _{IN} MAX = 5MHz at FS A _{IN} MAX = 10MHz at FS
Differential non-linearity	DNL	25	1	-0.85	±0.5	+1	LSB	
Integral non-linearity	INL	25	1		±1	±2	LSB	
S/N ratio	SNR	25	1	40.9	44.5		dBc	
			4		44.1		dBc	
			4		43.3		dBc	
Effective No. of bits	ENOB	25	1	6.5	7.1		bits	
			4		7.0		bits	
			4		6.9		bits	
Bit Error Rate	BER	25	4		1 in 10 ⁹			

ELECTRICAL CHARACTERISTICS DEFINITIONS**Analog Bandwidth**

The analog input frequency at which the spectral power of the fundamental frequency, as determined by Fast Fourier Transform analysis is 3dB down on the DC level.

Aperture Delay

The delay between the falling edge of the CLOCK signal and the instant at which the analog input is sampled.

Bit Error Rate (BER)

The number of spurious code errors produced for any given input sine wave frequency. In this case it is the number of codes occurring outside the histogram cusp for a $\frac{3}{4}$ F.S. sine wave.

Differential Non-Linearity (DNL)

The deviation of any code width from an ideal 1LSB step.

Effective Number of Bits (ENOB)

This is a measure of the dynamic performance and is calculated from the following expression.

$$\text{ENOB} = \frac{\text{SNR} - 1.76}{6.02}$$

SNR is the signal-to-noise ratio, in decibels, at the test frequency.

Integral Non-Linearity (INL)

The deviation of the centre of each code from a reference line which has been determined by a least squares curve fit.

Output Data Delay

The delay between the 50% point of the falling edge of the clock signal and the 50% point of any data output change.

Reference Ladder Offset

The voltage error at the ends of the resistor chain caused by the lead frame and bond wire.

Signal-to-Noise Ratio (SNR)

The ratio of the RMS signal amplitude to the RMS value of 'noise' which is defined as the sum of all other spectral components including harmonics but excluding DC with a full scale analog input signal.

Test Levels

Level 1 - 100% production tested

Level 2 - 100% production tested at 25°C and sample tested at specified temperatures

Level 3 - Sample tested only

Level 4 - Parameter is guaranteed by design and characteristics testing

Level 5 - Parameter is a typical value only

PIN DESCRIPTIONS

Pin No.	Function	Description
1, 2, 3, 4	D3, D2, D1, D0	Output data bits 3, 2, 1, 0
5	CLK	Clock input pin
6	CLK	Clock threshold level pin
7	V _{RB}	Bottom of reference resistor chain
8	AV _{CC}	} 5 Volt power to all circuitry except the TTL output
9	AGND	
10	V _{RM}	
11	V _{IN}	Middle of reference resistor chain
12	V _{RT}	Analog input voltage pin
13	DV _{CC}	Top of reference resistor chain
14	DGND	} 5 Volt power supply to the TTL output stage
15	D7	
16, 17, 18	D6, D5, D4	Most significant bit (output data bit 7) Output data bits 6, 5, 4

RECOMMENDED OPERATING CONDITIONS

Supply Voltage V _{CC}	+5.0V
Reference V _{RT}	+4.3V
Reference V _{RB}	+2.3V
AV _{CC} to DV _{CC}	0mV
AGND to DGND	0mV
Analog Input V _{IN}	2 Vp-p max

THERMAL CHARACTERISTICS

	DP	
Thermal resistance, chip-to-case θ_{jc}	20	°C/W
Thermal resistance, chip-to-ambient θ_{ja}	75	°C/W

SP973T8

APPLICATION NOTES

Analog Input Pin (Fig.3)

The analog input of the SP973T8 is connected to 256 comparators which have a combined capacitance of about 30pF. The sample/latch operation of the comparators causes the input capacitance to vary slightly as the comparator input transistors turn on/off. For this reason the input driver circuit should provide a low impedance signal to keep the harmonic distortion levels of the driver to a minimum.

The maximum amplitude of the analog input is defined by the setting of the two reference voltages V_{RT} and V_{RB} . Optimum performance will be obtained with the input signal biased midway between V_{RT} and V_{RB} with a peak to peak amplitude of $V_{RT}-V_{RB}$. The SP973T8 has excellent overload tracking of input signals with amplitudes greater than $V_{RT}-V_{RB}$, and will not be damaged if the absolute maximum ratings are adhered to.

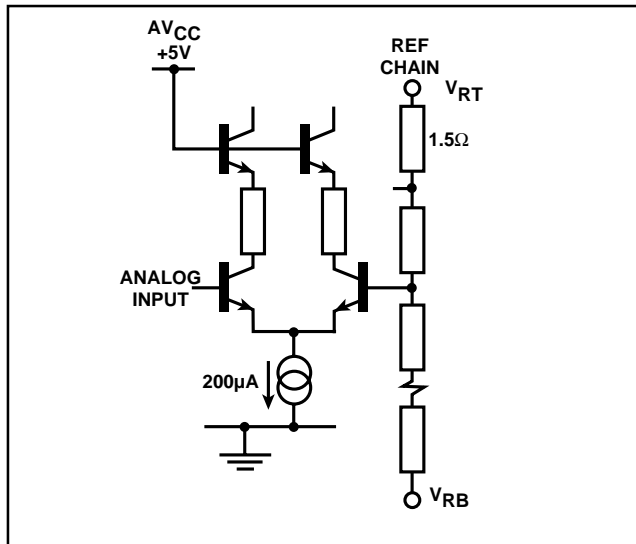

Fig.3 One of 255 analog inputs connected to pin 11

Voltage Reference Pins (Fig.4)

The SP973T8 converts analog signals in the range $V_{RB} < V_{IN} < V_{RT}$ into digital format, where V_{RB} produces code 0 and V_{RT} produces code 255. Between the pins V_{RT} and V_{RB} are a series of 256 resistors forming a reference chain with a total resistance of 425Ω (typically). The centre point of the reference chain is also connected to an external pin named V_{RM} by which it is possible to provide precision trimming of the integral linearity of the device.

The maximum value of V_{RT} is $V_{CC}-0.7$ volts since values above this figure will start to saturate the comparator, resulting in noticeable distortion. Optimum performance from a +5 Volt power supply is obtained with $V_{RT} < +4.3V$ and V_{RB} a further 2 volts below V_{RT} . In addition the V_{RT} , V_{RB} and V_{RM} pins should be decoupled to ground close to the device pins using good quality 10nf capacitors. A simple method for providing the reference voltages is shown in Fig.4, and further information may be found in applications note AN72. With a reference ladder voltage of less than 2V the reduced LSB size causes a larger differential linearity error. Operation of the device below 1.5V may therefore cause missing codes.

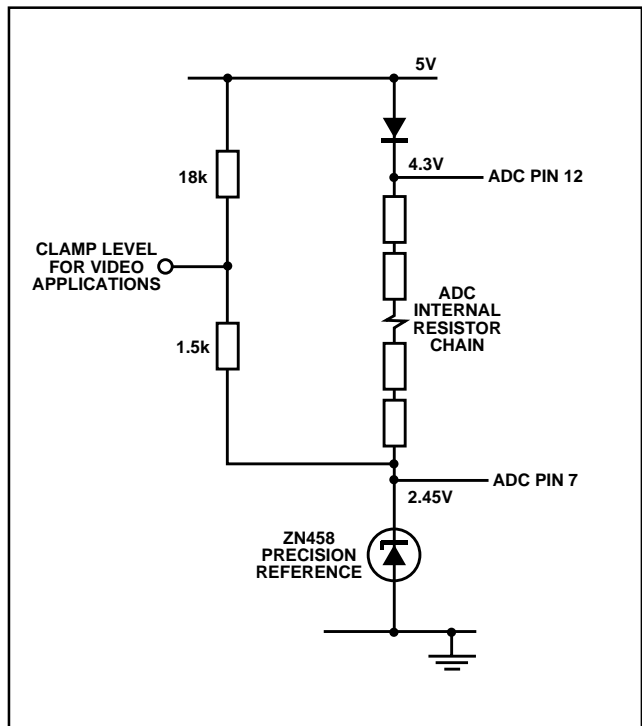

Fig.4 Simple reference voltage generation

TTL/CMOS Outputs (Fig.5)

The data output levels of the SP973T8 are TTL/CMOS compatible and switch from 0V to +4V. The output circuit is capable of operation at clock frequencies in excess of 60MHz when driving into a standard LSTTL load.

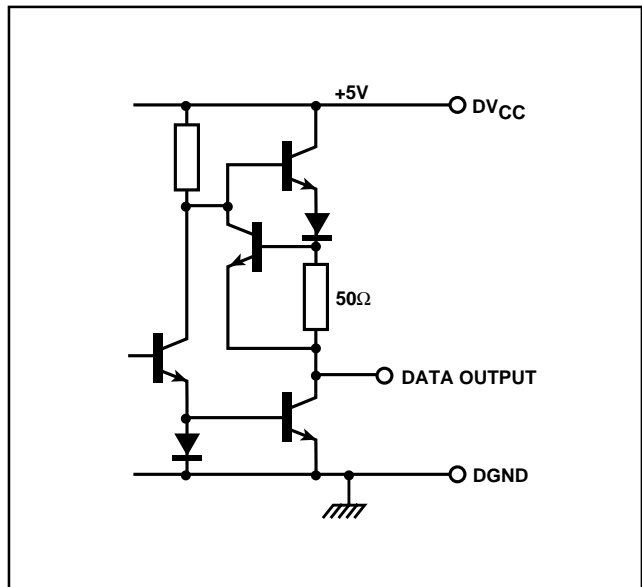

Fig.5 TTL output stage

Clock Input (Fig.6)

The SP973T8 will operate at clock frequencies up to and above 30MHz. The clock input has been designed to accept a 1Vpp signal, in either differential or single-ended mode, between the $V_{IH(MAX)}$ and $V_{IL(MIN)}$ levels indicated in the electrical specification. At $V_{IH(MAX)}$ or $V_{IL(MIN)}$ the \overline{CLK} input will sink $800\mu A$ or source $3.2mA$ of current, respectively. (See Fig.6).

When used in single-ended operation, \overline{CLK} may be decoupled to ground so that this input will then self-bias at approximately 1.2V below the supply V_{CC} . It may then be used to bias the \overline{CLK} input, through a termination resistor, for AC-coupled applications as shown in Fig.8.

Alternatively a TTL level clock may be used by inserting an appropriate value resistor in series with the coupling capacitor.

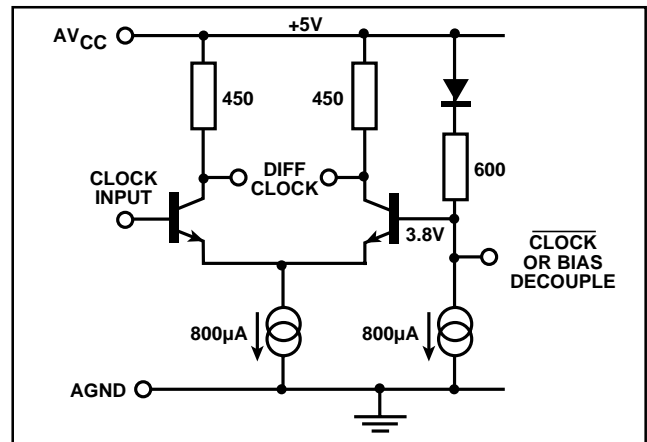

Fig.6 Clock input stage

TIMING (Fig.7)

The analog input is sampled by the SP973T8 approximately $3ns$ (t_{AD}) after the falling edge of the clock. Due to the pipeline operation of the device, a further one clock cycle is required to produce the output data. As shown in Fig.7, the output has a good data valid time, enabling the data to be latched at both the rising and falling edges of the clock.

However, for clock frequencies above 25MHz the clock-to-output delay time may lead to an inadequate data set up time relative to the rising clock edge and it is therefore recommended that the output data is latched on the falling clock edge.

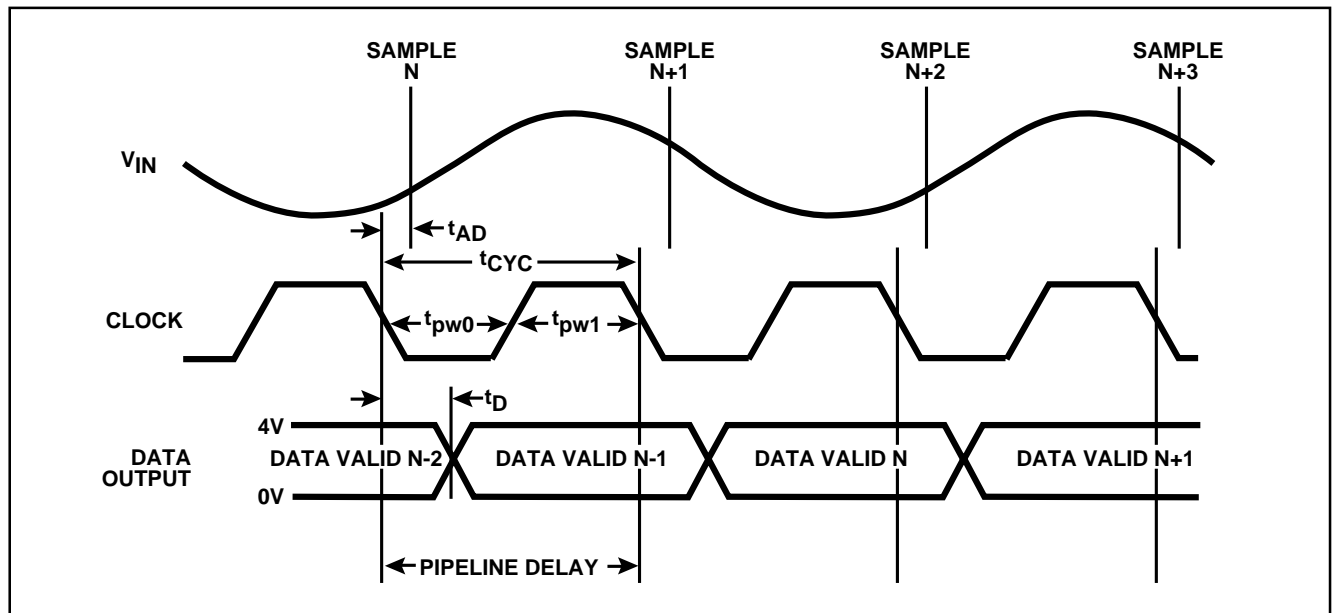

Fig.7 Timing diagram

SP973T8

Circuit Board Construction (Fig.8)

Excellent performance can be obtained from this ADC using only one solid ground plan for both analog and digital signals.

With all flash ADCs it is important to restrict digital crosstalk into the input, not only within the wanted signal bandwidth but also at frequencies between Nyquist and clock, as such signals will be aliased down into the wanted signal bandwidth.

We can give the designer two useful suggestions to reduce the above. First, due to the on-chip clock regeneration circuit, a low level clock can be fed to the ADC 1V p-p is

recommended. The second suggestion is the addition of a small bead inductor in series with and close to the device analog input.

Supply line decoupling is very important when dealing with a mix of analog and digital signals as they can provide a source of digital feedback from the digital output currents. It is wise, therefore, to decouple the SP973T8 close to the device supply pins with good quality, high frequency, low inductance capacitors.

Due to the high clock rates involved, long clock lines to the device should be avoided to reduce the noise pick up.

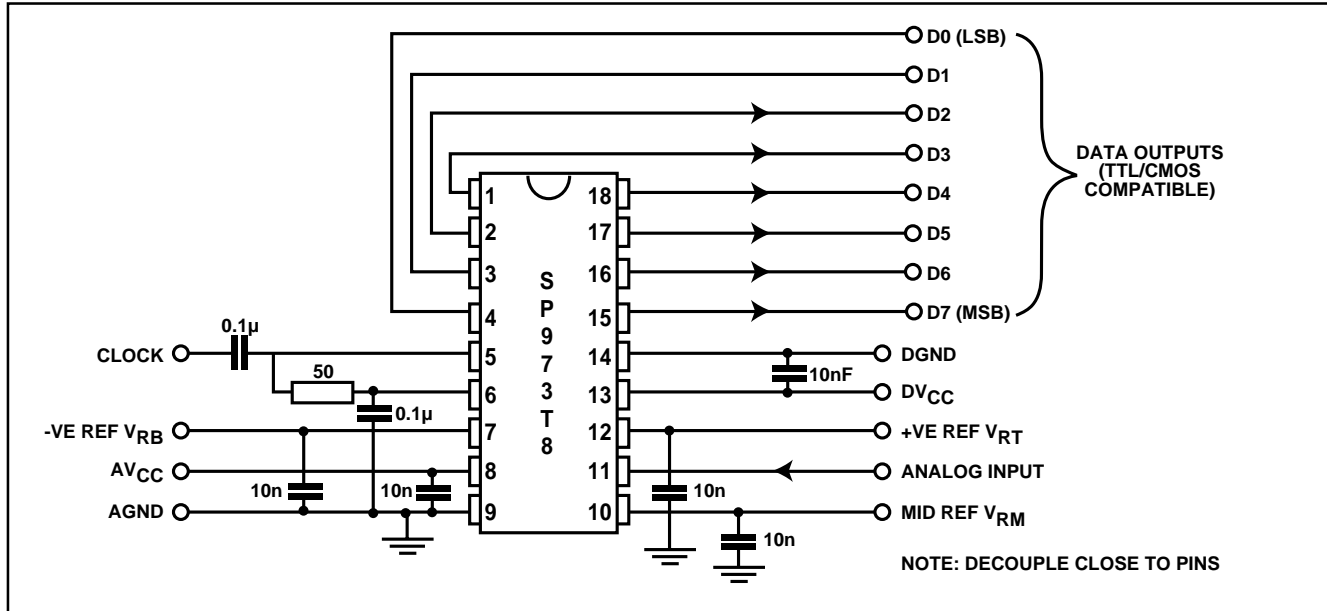

Fig.8 Test/application circuit



HEADQUARTERS OPERATIONS
GEC PLESSEY SEMICONDUCTORS
Cheney Manor, Swindon,
Wiltshire SN2 2QW, United Kingdom.
Tel: (0793) 518000
Fax: (0793) 518411

GEC PLESSEY SEMICONDUCTORS
P.O. Box 660017
1500 Green Hills Road,
Scotts Valley, California 95067-0017,
United States of America.
Tel: (408) 438 2900
Fax: (408) 438 5576

CUSTOMER SERVICE CENTRES

- **FRANCE & BENELUX** Les Ulis Cedex Tel: (1) 64 46 23 45 Fax : (1) 64 46 06 07
- **GERMANY** Munich Tel: (089) 3609 06-0 Fax : (089) 3609 06-55
- **ITALY** Milan Tel: (02) 66040867 Fax: (02) 66040993
- **JAPAN** Tokyo Tel: (03) 5276-5501 Fax: (03) 5276-5510
- **NORTH AMERICA Integrated Circuits and Microwave Products** Scotts Valley, USA
Tel (408) 438 2900 Fax: (408) 438 7023.
Hybrid Products, Farmingdale, USA Tel (516) 293 8686 Fax: (516) 293 0061.
- **SOUTH EAST ASIA** Singapore Tel: (65) 3827708 Fax: (65) 3828872
- **SWEDEN** Stockholm, Tel: 46 8 702 97 70 Fax: 46 8 640 47 36
- **UK, EIRE, DENMARK, FINLAND & NORWAY**
Swindon Tel: (0793) 518510 Fax : (0793) 518582

These are supported by Agents and Distributors in major countries world-wide.

© GEC Plessey Semiconductors 1994 Publication No. DS2465 Issue No. 2.3 January 1994