

H11B815

4-Pin Photodarlington Optocoupler

Description

The H11B815 consists of a gallium arsenide infrared emitting diode driving a silicon Darlington phototransistor in a 4-pin dual in-line package.

Features

- Compact 4-pin package
- Current Transfer Ratio: 600% minimum (at $I_F = 1$ mA)
- High isolation voltage between input and output (5300 VRMS)
- UL recognized (File # E90700)

Applications

- Power Supply Monitors
- Relay Contact Monitor
- Telephone/Telegraph Line Receiver
- Twisted Pair Line Receiver
- Digital Logic/Digital Logic

Package

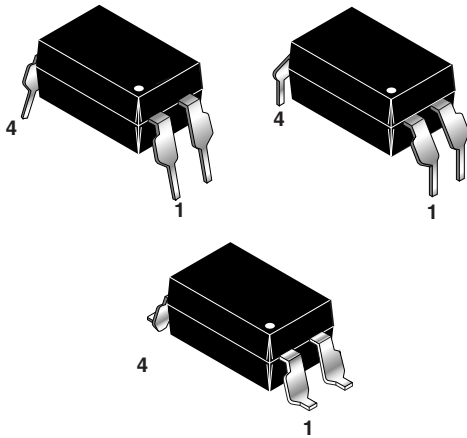

Schematic

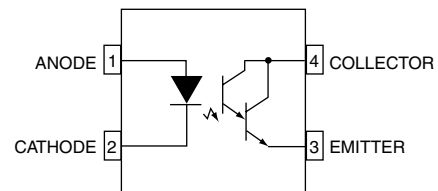

Absolute Maximum Ratings (No derating required up to 85°C)

Parameter	Symbol	Value	Units
TOTAL DEVICE			
Storage Temperature	T_{STG}	-55 to +150	°C
Operating Temperature	T_{OPR}	-55 to +100	°C
Lead Solder Temperature	T_{SOL}	260 for 10 sec	°C
Total Device Power Dissipation @ $T_A = 25^\circ\text{C}$	P_D	250	mW
EMITTER			
DC/Average Forward Input Current	I_F	50	mA
Reverse Input Voltage	V_R	6	V
Forward Current - Peak (1 μs pulse, 300pps)	$I_F(\text{pk})$	1	A
LED Power Dissipation @ $T_A = 25^\circ\text{C}$	P_D	70	mW
Derate above 25°C		1.33	mW/°C
DETECTOR			
Collector-Emitter Voltage	V_{CEO}	35	V
Emitter-Collector Voltage	V_{ECO}	6	V
Continuous Collector Current	I_C	80	mA
Detector Power Dissipation @ $T_A = 25^\circ\text{C}$	P_D	150	mW
Derate above 25°C		2.0	mW/°C

Electrical Characteristics ($T_A = 25^\circ\text{C}$ Unless otherwise specified.)**Individual Component Characteristics**

Parameter	Test Conditions	Symbol	Min	Typ**	Max	Unit
EMITTER						
Input Forward Voltage	($I_F = 20\text{ mA}$)	V_F		1.2	1.50	V
Reverse Leakage Current	($V_R = 6.0\text{ V}$)	I_R		0.001	10	μA
DETECTOR						
Collector-Emitter Breakdown Voltage	($I_C = 1.0\text{ mA}$, $I_F = 0$)	BV_{CEO}	35	60		V
Emitter-Collector Breakdown Voltage	($I_E = 100\ \mu\text{A}$, $I_F = 0$)	BV_{ECO}	6	8		V
Collector-Emitter Dark Current	($V_{CE} = 10\text{ V}$, $I_F = 0$)	I_{CEO}		0.005	1	μA
Capacitance	($V_{CE} = 0\text{ V}$, $f = 1\text{ MHz}$)	C_{CE}		8		pF

Transfer Characteristics

DC Characteristic	Test Conditions	Symbol	Min	Typ**	Max	Units
Current Transfer Ratio, Collector-Emitter	($I_F = 1 \text{ mA}$, $V_{CE} = 2 \text{ V}$)	CTR	600		7,500	%
Saturation Voltage	($I_F = 20 \text{ mA}$, $I_C = 5 \text{ mA}$)	$V_{CE(sat)}$		0.8	1.0	V
Rise Time (non saturated)	($I_C = 10 \text{ mA}$, $V_{CE} = 2 \text{ V}$, $R_L = 100\Omega$)	t_r			300	μs
Fall Time (non saturated)	($I_C = 10 \text{ mA}$, $V_{CE} = 2 \text{ V}$, $R_L = 100\Omega$)	t_f			250	μs

Isolation Characteristics

Characteristic	Test Conditions	Symbol	Min	Typ**	Max	Units
Input-Output Isolation Voltage	($I_{I-O} [1 \mu\text{A}, 1 \text{ min.}]$)	V_{ISO}	5000			Vac(rms)
Isolation Resistance	($V_{I-O} = 500 \text{ VDC}$)	R_{ISO}	10^{11}			Ω
Isolation Capacitance	($V_{I-O} = \&, f = 1 \text{ MHz}$)	C_{ISO}		0.5		pf

** All typicals at $T_A = 25^\circ\text{C}$

Typical Performance Curves

Fig. 1 Normalized Current Transfer Ratio vs. Forward Current

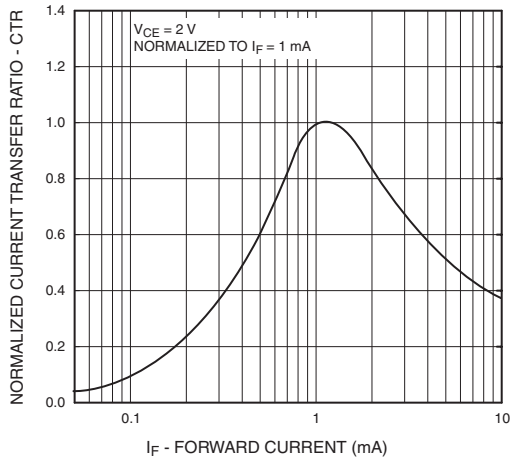

Fig. 2 Normalized Current Transfer Ratio vs. Ambient Temperature

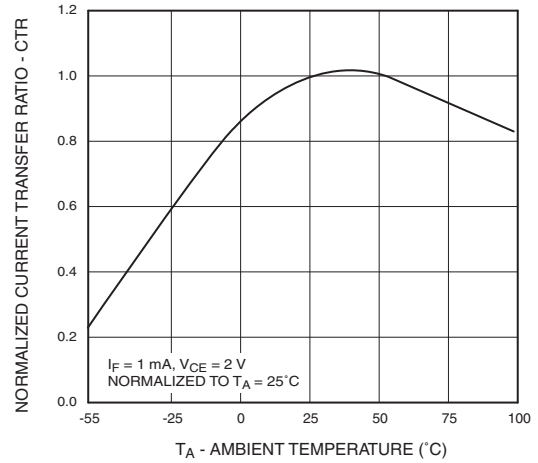

Fig. 3 Normalized Collector Current vs. Collector Emitter Voltage

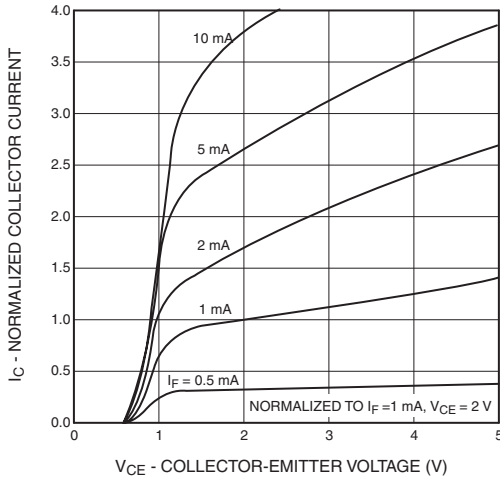

Fig. 4 Collector-Emitter Dark Current vs. Ambient Temperature

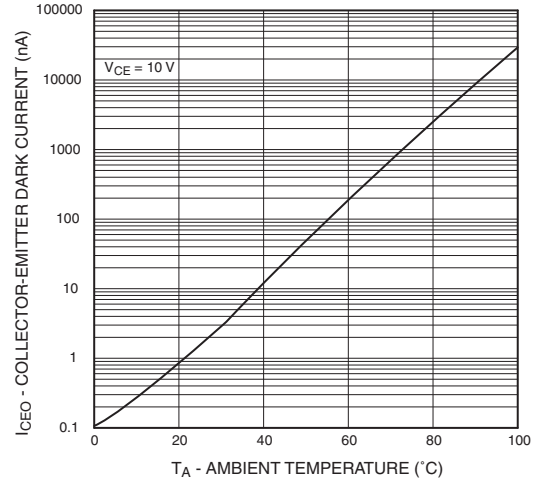
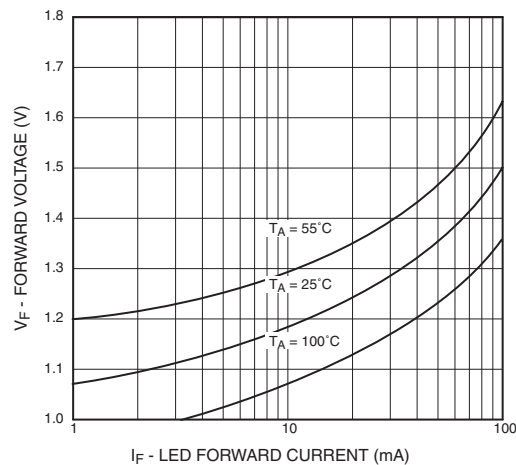
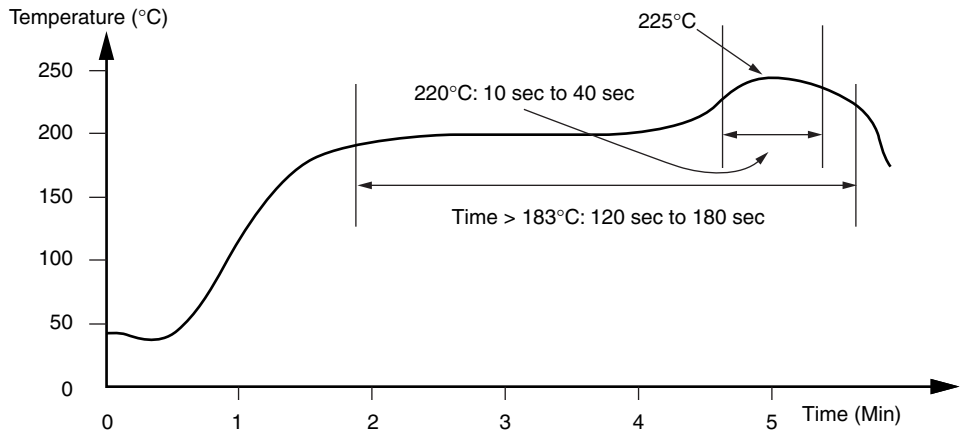

Fig. 5 LED Forward Voltage vs. Forward Current



Recommended Thermal Reflow Profile for Surface Mount DIP Package



Package Dimensions (Through Hole)

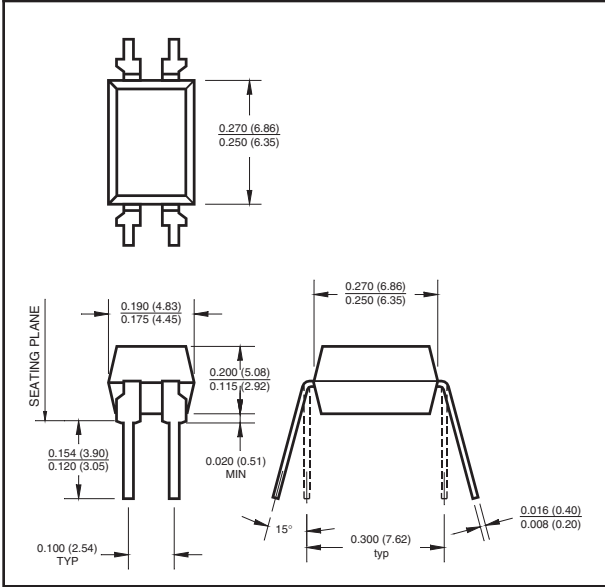

Package Dimensions (0.4" Lead Spacing)

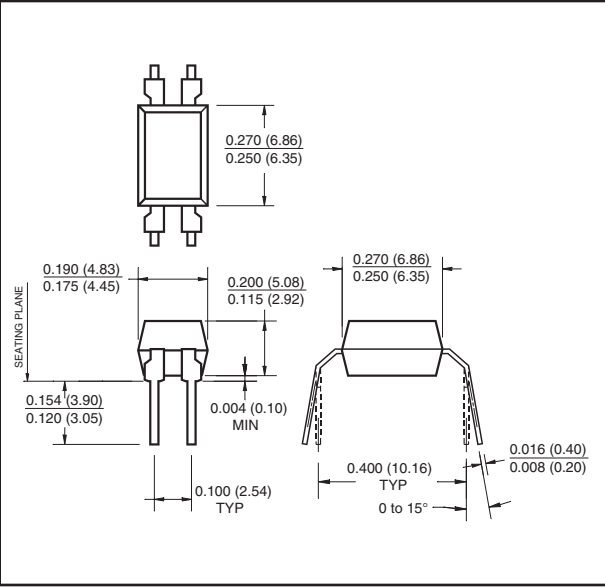

Package Dimensions (Surface Mount)

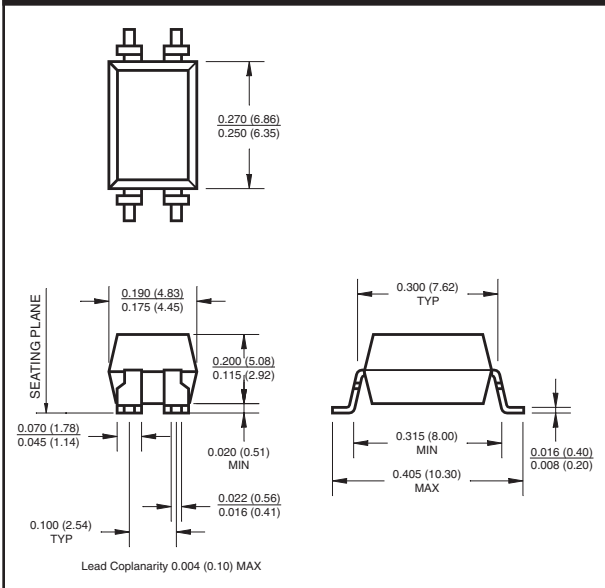

PCB Footprint Layout

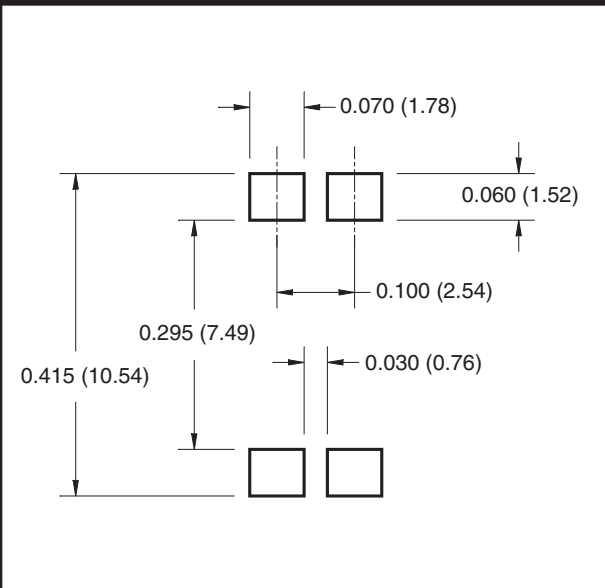

NOTE
All dimensions are in inches (millimeters)

Ordering Information

Option	Order Entry Identifier	Description
S	.S	Surface Mount Lead Bend
SD	.SD	Surface Mount; Tape and reel
W	.W	0.4" Lead Spacing
300	.300	VDE 0884
300W	.300W	VDE 0884, 0.4" Lead Spacing
3S	.3S	VDE 0884, Surface Mount
3SD	.3SD	VDE 0884, Surface Mount, Tape & Reel

Marking Information

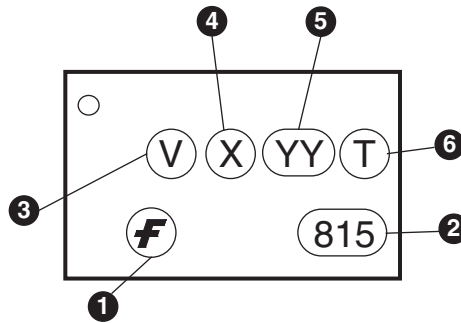

Definitions	
1	Fairchild logo
2	Device number
3	VDE mark (Note: Only appears on parts ordered with VDE option – See order entry table)
4	One digit year code
5	Two digit work week ranging from '01' to '53'
6	Assembly package code

Carrier Tape Specifications

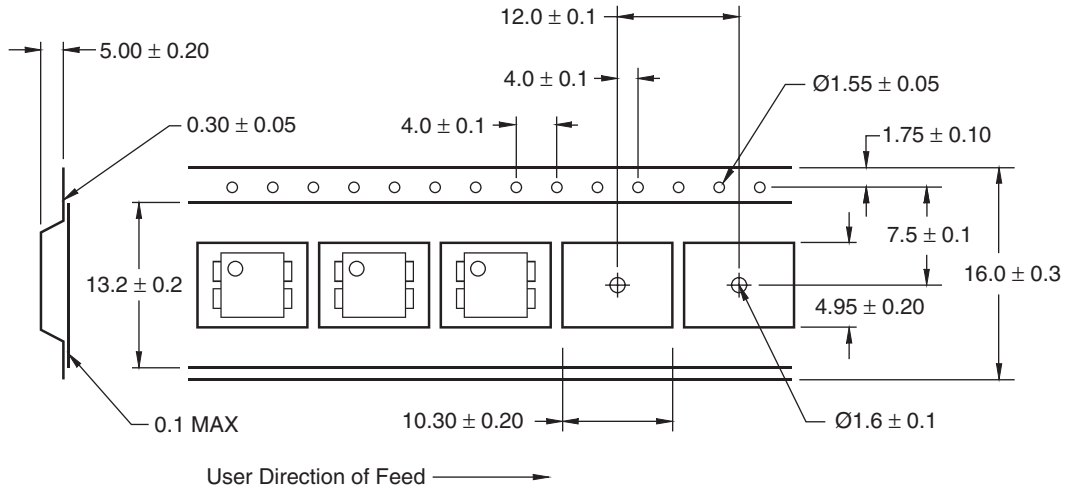

NOTE

All dimensions are in millimeters

TRADEMARKS

The following are registered and unregistered trademarks Fairchild Semiconductor owns or is authorized to use and is not intended to be an exhaustive list of all such trademarks.

ACEx™	FAST®	ISOPLANAR™	PowerSaver™	SuperSOT™-8
ActiveArray™	FASTr™	LittleFET™	PowerTrench®	SyncFET™
Bottomless™	FPS™	MICROCOUPLER™	QFET®	TinyLogic®
Build it Now™	FRFET™	MicroFET™	QS™	TINYOPTO™
CoolFET™	GlobalOptoisolator™	MicroPak™	QT Optoelectronics™	TruTranslation™
CROSSVOLT™	GTO™	MICROWIRE™	Quiet Series™	UHC™
DOME™	HiSeC™	MSX™	RapidConfigure™	UltraFET®
EcoSPARK™	I ² C™	MSXPro™	RapidConnect™	UniFET™
E ² CMOS™	i-Lo™	OCX™	μSerDes™	VCX™
EnSigna™	ImpliedDisconnect™	OCXPro™	SILENT SWITCHER®	Wire™
FACT™	IntelliMAX™	OPTOLOGIC®	SMART START™	
FACT Quiet Series™		OPTOPLANAR™	SPM™	
Across the board. Around the world.™		PACMAN™	Stealth™	
The Power Franchise®		POP™	SuperFET™	
Programmable Active Droop™		Power247™	SuperSOT™-3	
		PowerEdge™	SuperSOT™-6	

DISCLAIMER

FAIRCHILD SEMICONDUCTOR RESERVES THE RIGHT TO MAKE CHANGES WITHOUT FURTHER NOTICE TO ANY PRODUCTS HEREIN TO IMPROVE RELIABILITY, FUNCTION OR DESIGN. FAIRCHILD DOES NOT ASSUME ANY LIABILITY ARISING OUT OF THE APPLICATION OR USE OF ANY PRODUCT OR CIRCUIT DESCRIBED HEREIN; NEITHER DOES IT CONVEY ANY LICENSE UNDER ITS PATENT RIGHTS, NOR THE RIGHTS OF OTHERS.

LIFE SUPPORT POLICY

FAIRCHILD'S PRODUCTS ARE NOT AUTHORIZED FOR USE AS CRITICAL COMPONENTS IN LIFE SUPPORT DEVICES OR SYSTEMS WITHOUT THE EXPRESS WRITTEN APPROVAL OF FAIRCHILD SEMICONDUCTOR CORPORATION. As used herein:

1. Life support devices or systems are devices or systems which, (a) are intended for surgical implant into the body, or (b) support or sustain life, or (c) whose failure to perform when properly used in accordance with instructions for use provided in the labeling, can be reasonably expected to result in significant injury to the user.
2. A critical component is any component of a life support device or system whose failure to perform can be reasonably expected to cause the failure of the life support device or system, or to affect its safety or effectiveness.

PRODUCT STATUS DEFINITIONS

Definition of Terms

Datasheet Identification	Product Status	Definition
Advance Information	Formative or In Design	This datasheet contains the design specifications for product development. Specifications may change in any manner without notice.
Preliminary	First Production	This datasheet contains preliminary data, and supplementary data will be published at a later date. Fairchild Semiconductor reserves the right to make changes at any time without notice in order to improve design.
No Identification Needed	Full Production	This datasheet contains final specifications. Fairchild Semiconductor reserves the right to make changes at any time without notice in order to improve design.
Obsolete	Not In Production	This datasheet contains specifications on a product that has been discontinued by Fairchild semiconductor. The datasheet is printed for reference information only.

Rev. 116

Home >> Find products >>

H11B815

4-Pin DIP Photodarlington Output Optocoupler

Contents

- [General description](#)
- [Features](#)
- [Applications](#)
- [Ordering information](#)
- [Product status/pricing/packaging](#)
- [Order Samples](#)
- [Safety agency certificates](#)
- [Qualification Support](#)

General description

The H11B815 consists of a gallium arsenide infrared emitting diode driving a silicon Darlington phototransistor in a 4-pin dual-in-line package.

[back to top](#)

Features

- Compact 4-pin package
- Current transfer ratio: 600% minimum (at $I_F = 1 \text{ mA}$)
- High isolation voltage between input and output (5300 VRMS)
- UL recognized (File #E90700)

[back to top](#)

Applications

- Power supply monitors
- Relay contact monitor
- Telephone/telegraph line receiver
- Twisted pair line receiver
- Digital logic/Digital logic

[back to top](#)

BUY

Datasheet

[Download this datasheet](#)



[e-mail this datasheet](#)



This page

[Print version](#)

Related Links

[Request samples](#)

[How to order products](#)

[Product Change Notices \(PCNs\)](#)

[Support](#)

[Sales support](#)

[Quality and reliability](#)

[Design center](#)

Ordering information









The following options can be ordered with this part:

Option	Order Entry Identifier	Description
S	.S	Surface Mount Lead Bend
SD	.SD	Surface Mount; Tape and Reel
W	.W	0.4" Lead Spacing
300	.300	VDE 0884
300W	.300W	VDE 0884, 0.4" Lead Spacing
3S	.3S	VDE 0884, Surface Mount
3SD	.3SD	VDE 0884, Surface Mount, Tape & Reel

[back to top](#)

Product status/pricing/packaging

BUY

Product	Product status	Pb-free Status	Package type	Leads	Packing method
H11B815	Lifetime Buy		DIP-B	4	BOX
H11B815300	Lifetime Buy		DIP-B	4	BOX
H11B815300W	Lifetime Buy		DIP-B	4	BOX
H11B8153S	Lifetime Buy		SMDIP-B	4	BOX
H11B8153SD	Lifetime Buy		SMDIP-B	4	TAPE REEL
H11B815S	Lifetime Buy		SMDIP-B	4	BOX
H11B815SD	Lifetime Buy		SMDIP-B	4	TAPE REEL
H11B815W	Lifetime Buy		DIP-B	4	BOX



Indicates product with Pb-free second-level interconnect. For more information [click here](#).

[back to top](#)

Safety agency certificates

Certificate	Agency	
512040 (4502 K)	SEMKO	SEMKO
P05204910 (406 K)	NEMKO	NEMKO
FI 21978 (208 K)	FIMKO	FIMKO
313540-02 (199 K)	DEMKO	DEMKO Testing & Certification
E90700, Vol. 1 (936 K)	UL (1577)	Underwriters Laboratories Inc.
E90700, Vol. 1 (936 K)	C-UL	Underwriters Laboratories Inc.
P03200748 (1990 K)	NEMKO	NEMKO
1027742 (2305 K)	CSA	Canadian Standards Association
307285 (329 K)	SEMKO	SEMKO
104801 (660 K)	VDE	VDE Pruf-und Zertifizierungsinstitut
312446-01 (152 K)	DEMKO	DEMKO Testing & Certification
FI 20127 (747 K)	FIMKO	FIMKO

[back to top](#)

Qualification Support

Click on a product for detailed qualification data

Product
H11B815
H11B815300
H11B815300W
H11B8153S
H11B8153SD
H11B815S
H11B815SD
H11B815W

[back to top](#)

