

SMD TYPE

SVE

- Voltage Controlled Crystal Oscillator
- CMOS Output
- 3.3V, 5.0V Supply Voltage
- Wide Frequency and Pull Range
- Surface Mount Package
- Available on Tape and Reel

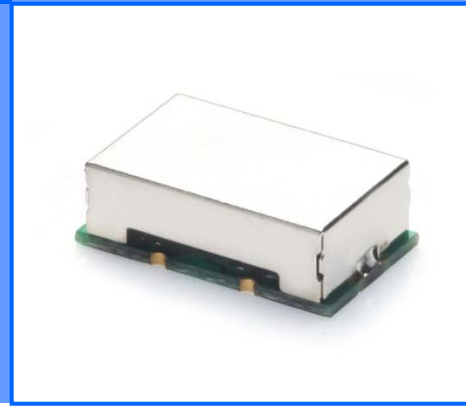

ELECTRICAL SPECIFICATIONS

ITEM	Value	Remarks
Output Logic Type	CMOS	CMOS VCXO
Frequency Range	1.000 to 60.000 MHz	Fundamental
Supply Voltage(V _{DD})	3.3 V _{DC} , 5.0 V _{DC} ±5 %	
Operating Temperature Range	-20 to +70 °C, -40 to +85 °C	
Storage Temperature Range	-55 to +125 °C	
Frequency Stability	±20 ppm, ±25 ppm, ±30 ppm, ±50 ppm, ±100 ppm Max.	Over operating temperature range
Input Current	20 mA(5V), 15 mA(3.3V) Max. 30 mA(5V), 25 mA(3.3V) Max. 40 mA(5V), 35 mA(3.3V) Max.	1.000 to 20.000 MHz 20.001 to 40.000 MHz 40.001 to 60.000 MHz
Output Voltage Logic High(V _{OH})	90 % of V _{DD} Min.	
Output Voltage Logic Low(V _{OL})	10 % of V _{DD} Max.	
Rise / Fall Time	10 ns Max.(1.000 to 20.000 MHz) 8 ns Max.(20.001 to 40.000 MHz) 5 ns Max.(40.001 to 60.000 MHz)	Measured over 10 % to 90 % of waveform
Duty Cycle	45 to 55 %, 40 to 60 %	Measured at 50 % of waveform
Start-up Time	10 ms Max.	
Output Load Condition(CMOS)	15 pF Max.	
Frequency Deviation	±50 ppm, ±80 ppm, ±100 ppm Min.	Over V _c range
Control Voltage(V _c)	2.5 V ±2.0 V, 1.65 V ±1.35 V	Please specify
Linearity	10 % Max.	
Output Enable Function (V _{IH} and V _{IL})	70 % of V _{DD} Min. to Enable Output 30 % of V _{DD} Max. to Disable Output	High Impedance
RMS Phase Jitter	1 ps Max.	BW : 12 kHz to 20 MHz
Frequency Aging	±5 ppm Max.	25°C, First year

MECHANICAL DIMENSIONS

(mm)

LAND PATTERN

(mm)

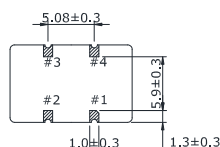
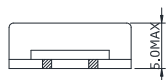
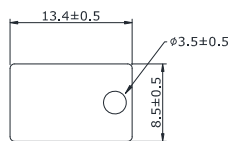

CONNECTION

- #1 : V_C
- #2 : GND
- #3 : OUTPUT
- #4 : V_{DD}

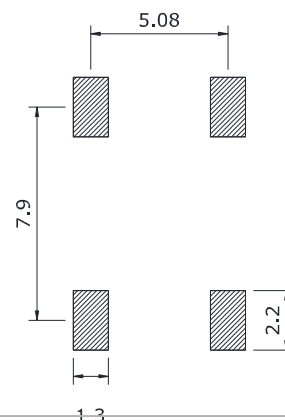

PART NUMBERING GUIDE

SVE 33 30 F D D R - 27.000M

SUPPLY VOLTAGE(V_{DD})

50 : 5.0 V, 33 : 3.3 V

FREQUENCY STABILITY

TABLE 1

OPERATING TEMPERATURE RANGE

TABLE 1

DUTY CYCLE

D : 45/55

E : 40/60

DEVIATION

A : ±30 ppm min. B : ±50 ppm min.

C : ±80 ppm min. D : ±100 ppm min.

E : ±130 ppm min. F : ±150 ppm min.

FREQUENCY

M : MHz

PACKAGE OPTION

R : TAPE AND REEL

BLANK : BULK

TABLE 1

FREQUENCY STABILITY VS. TEMPERATURE RANGE

Temp	Stability	±15	±20	±25	±30	±50	±100
		15	20	25	30	50	100
0~50 °C	A	*	*	*	*	*	*
0~60 °C	B		*	*	*	*	*
-10~60 °C	C		*	*	*	*	*
0~70 °C	D		*	*	*	*	*
-10~70 °C	E		*	*	*	*	*
-20~70 °C	F		*	*	*	*	*
-40~85 °C	G			*	*	*	*

TEST CIRCUIT (CMOS)

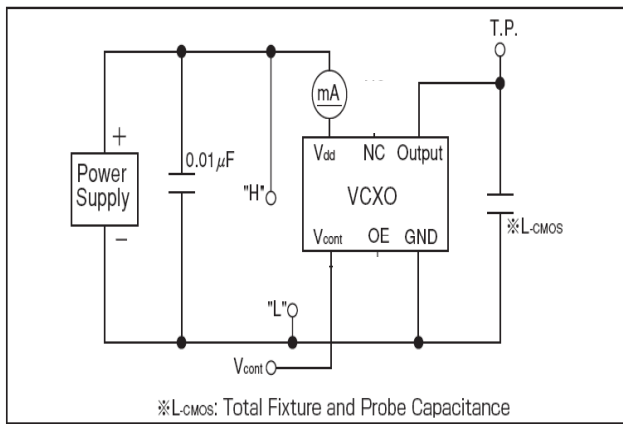

WAVEFORM (CMOS)

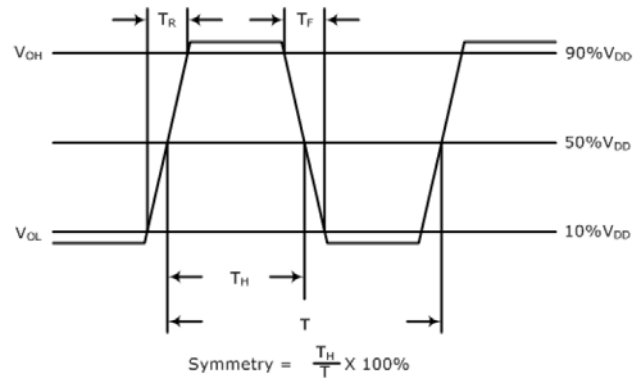

ENVIRONMENTAL & MECHANICAL SPECIFICATIONS

Temperature Cycling	MIL-STD-883, Method 1010, Condition B
Fine Leak Test	MIL-STD-883, Method 1014, Condition A
Gross Leak Test	MIL-STD-883, Method 1014, Condition C
Mechanical Shock	MIL-STD-202, Method 213, Condition C
Vibration	MIL-STD-883, Method 2007, Condition A
Moisture Resistance	MIL-STD-883, Method 1004
Moisture Sensitivity	J-STD-020, MSL 1
Resistance to Soldering Heat	MIL-STD-202, Method 210, Condition K
Solderability	MIL-STD-883, Method 2003

REFLOW PROFILE

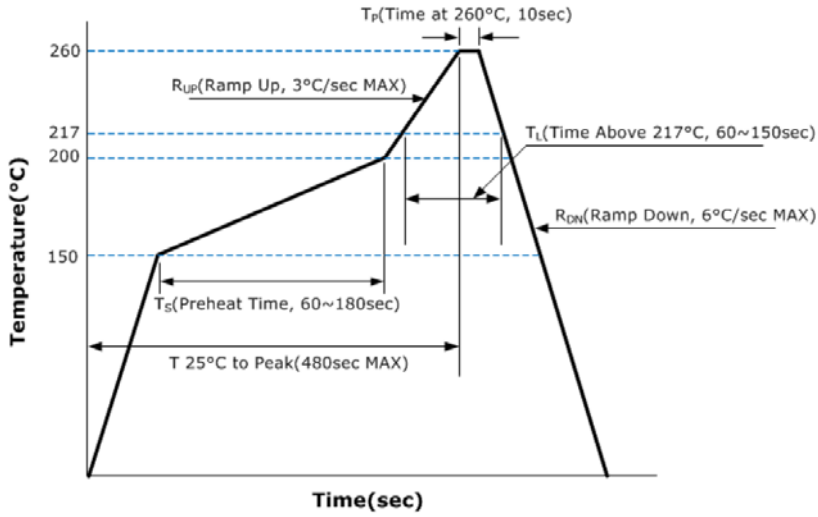

MARKING GUIDE

Frequency in MHz

Model Name

LINE 1 : **SVE25DDM**

LINE 2 : **XX.XXX (3)**

LINE 3 : **● SUNNY YY MM**

Year

Month

Supply Voltage