

2260B

Type N Female to 7/8 in EIA Flange Adapter

OBSOLETE

Replaced By:

2260B-2-S

Type N Female to 7/8 in EIA Flange Adapter

Product Classification

Product Type Adapter

General Specifications

Body Style Straight

Inner Contact Plating Silver

Interface 7/8 in EIA Flange

Interface 2 N Female

Mounting Angle Straight

Outer Contact Plating Copper alloy treatment

Pressurizable No

Dimensions

Length 79.5 mm | 3.13 in

Diameter 56.93 mm | 2.241 in

Outline Drawing

2260B

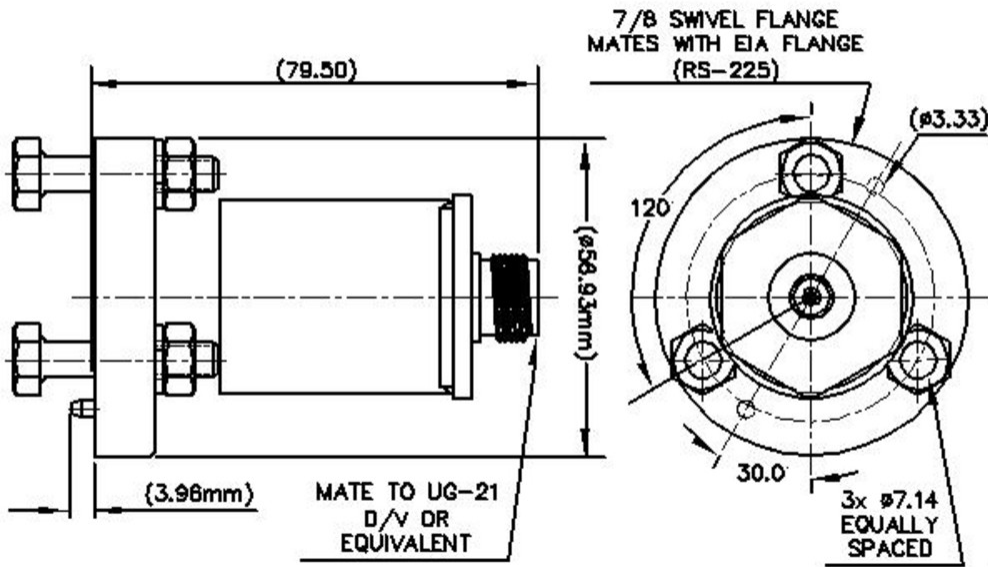

Electrical Specifications

Average Power at Frequency	300.0 W @ 900 MHz
Connector Impedance	50 ohm
dc Test Voltage	2000 V
Inner Contact Resistance, maximum	5 mOhm
Insulation Resistance, minimum	5000 MOhm
Operating Frequency Band	0 – 3000 MHz
Outer Contact Resistance, maximum	5 mOhm

VSWR/Return Loss

Frequency Band	VSWR	Return Loss (dB)
0–1500 MHz	1.2	20.83
1500–3000 MHz	1.35	16.54

Mechanical Specifications

Insertion Force	28 N 6.295 lbf
Insertion Force Method	IEC 61169-16:9.3.5
Interface Durability	500 cycles
Interface Durability Method	IEC 61169-12:9.5
Mechanical Shock Test Method	IEC 60068-2-27

2260B

Environmental Specifications

Operating Temperature	-55 °C to +85 °C (-67 °F to +185 °F)
Storage Temperature	-65 °C to +125 °C (-85 °F to +257 °F)
Attenuation, Ambient Temperature	20 °C 68 °F
Average Power, Ambient Temperature	40 °C 104 °F
Average Power, Inner Conductor Temperature	100 °C 212 °F
Climatic Sequence Test Method	IEC 60068-1
Corrosion Test Method	IEC 60068-2-11
Damp Heat Steady State Test Method	IEC 60068-2-3
Thermal Shock Test Method	IEC 60068-2-14
Vibration Test Method	IEC 60068-2-6

Packaging and Weights

Weight, net	453.59 g 1 lb
--------------------	-----------------

Regulatory Compliance/Certifications

Agency	Classification
ISO 9001:2015	Designed, manufactured and/or distributed under this quality management system

