

SMB3100W-9058

SMB Plug Crimp Right Angle 50Ω

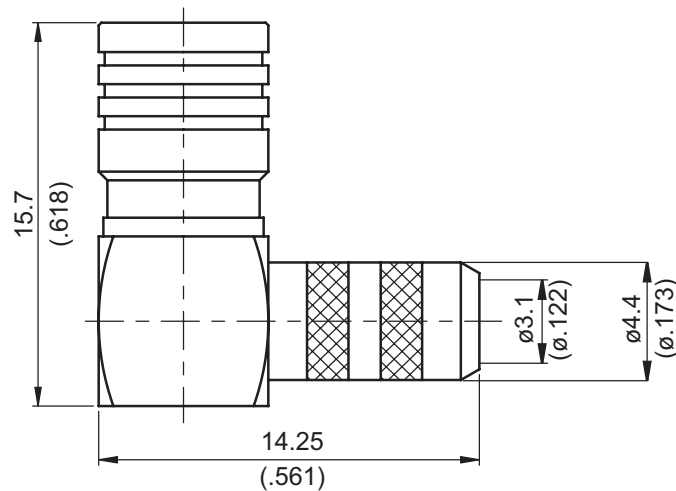

Parts	Material	Plating (Micro-inch)
Ferrule	Brass	Gold 5 Over Nickel 50 Over Copper 50
Contact Pin	Phosphor Bronze	Gold 20 Over Nickel 50 Over Copper 50
Retainer Ring	Beryllium Copper	Tin-Zinc-Copper-Alloy 100 Over Copper 50
Insulator	Teflon	
Body	Brass	Tin-Zinc-Copper-Alloy 100 Over Copper 50
Barrel	Brass	Tin-Zinc-Copper-Alloy 100 Over Copper 50
Coupling Nut	Brass	Tin-Zinc-Copper-Alloy 100 Over Copper 50
Cover	Brass	Gold 5 Over Nickel 50 Over Copper 50

Weight:
Suitable Cables: RG58, JBY195

This part number complies with RoHS.
Notice: JYEBAO reserves the right to make modifications deemed appropriate.

CABLE ASSEMBLY INSTRUCTION

SMB3100W-9058

JYE BAO CO., LTD.

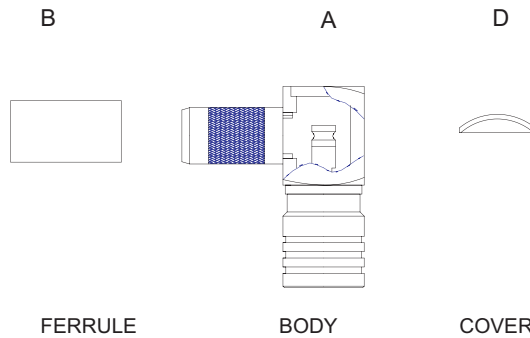

* TOOLS AND FIXTURES ARE REFERENCE ON
PAGE 306 OF JYEBAO'S 2005 CATALOG.

DIAGRAM	ASSEMBLY INSTRUCTION
	<p>Step 1: STRIP AS SHOWN .</p>
	<p>Step 2: SLIDE FERRULE 'B' OVER CABLE . Step 3: WRAP THE BRAIDING UPWARDS. Step 4: SLIDE CENTER CONDUCTOR ON THE CONTACT PIN OF CONNECTOR 'A' AND SOLDER IN "Y"</p>
	<p>Step 5: SLIDE FERRULE 'B' TOWARDS THE CONNECTOR 'A' AND CRIMP .</p>
	<p>Step 6: PRESS ON THE TOP OF 'D' WITH JIGS AS SHOWN .</p>

This part number complies with RoHS.

Notice: JYEBAO reserves the right to make modifications deemed appropriate.