

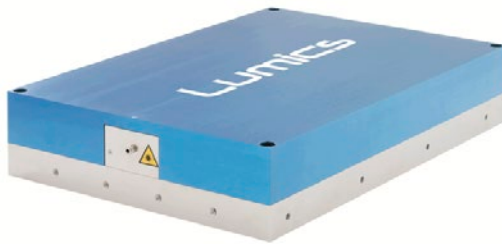

LuOcean M2

LU09xxA Diode Laser
Up to 750 W c.w. Operating Power



Description:

The **LuOcean M2** device consists of multiple single emitter laser diodes in a rugged industrial package. Long lifetime is ensured due to laser diode facet passivation, extensive burn-in testing and screening of the individual single emitters. Its performance makes it a valuable tool for various applications.

Features & Functions:

- Wavelength 915, 940 or 976 nm
- Burn-in tested single emitters
- D80 connector
- Sealed housing
- Internal cooling
- Temperature sensor
- Power monitor

Options:

- Up to 2 fiber sensors
- Up to 2 temperature sensors
- Red pilot laser
- Backreflection filter
- Replaceable protection window

Benefits:

- No DI water required
- Low current
- Ultra long lifetime

Applications:

- Material processing
- Pumping
- Illumination

Module Drawing (Dimensions in mm)

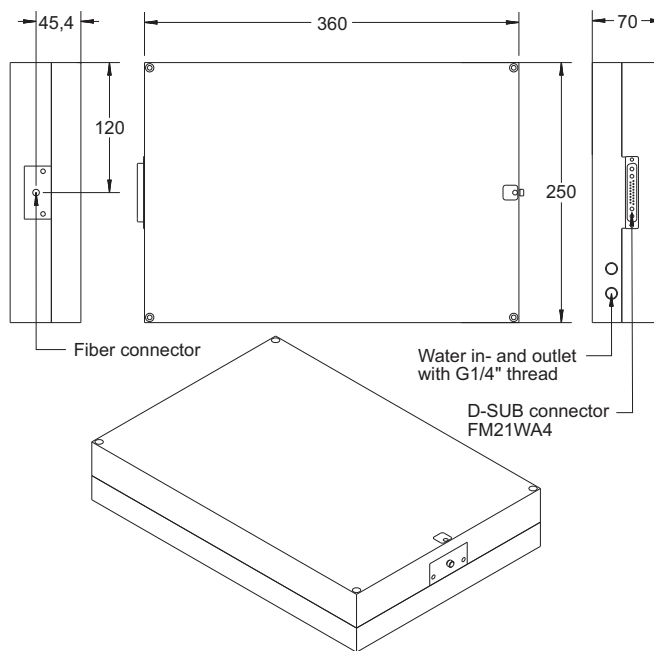

Connector

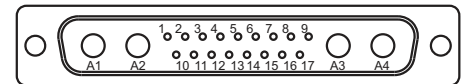

Pin Connections

1	V _s =12 V for Fiber sensor* / Monitor diode cathode (12 V)
2	GND for Fiber sensor*/LM35*/Monitor diode
3	Fiber sensor 1 signal*
4	Fiber sensor 2 signal*
5	NTC 1 or LM35 5 V or PT100/1000
6	NTC 1 signal or LM35 signal or PT100/1000
7	NTC 2 or LM35 5 V or PT100/1000 *
8	NTC 2 signal or LM35 signal or PT100/1000 *
9	Monitor diode 1 signal
10	Monitor diode 2 signal*
11	Pilot laser (3-5 V)*
12	Pilot laser (GND)*
13	Pilot laser power control (0-5 V)*
14	NTC 3 or LM35 5 V or PT100/1000 *
15	NTC 3 signal or LM35 signal or PT100/1000 *
16/17	N. C.
A1	Laser diode GND (-)
A2	N. C.
A3	N. C.
A4	Laser diode (+)
* = optional	

Your ideas are welcome.

Electrical and Optical Characteristics

Typical laser specifications at 25° C*

Parameter	Conditions	Symbol	400W in 400µm	500W in 400µm	750W in 600µm	Unit
Output power (1)	c.w.	P _{op}	400	500	750	W
Operating current	c.w.	I _{op}	25	18	25	A
Absolut max. forward current	c.w.	I _{max}	27	19	27	A
Peak wavelength (2)	LU0915A		915 ± 10	915 ± 10	915 ± 10	nm
	LU0940A		940 ± 10	940 ± 10	940 ± 10	nm
	LU0975A		976 ± 10	976 ± 10	976 ± 10	nm
Spectral width (FWHM)		Δλ	6	6	6	nm
Spectral width (90%)		Δλ _{90%}	9	9	9	nm
Threshold current		I _{th}	<2.5	<1	<2.5	A
Operating voltage		V _f	41	81	81	V
Conversion efficiency			40	35	35	%
Wavelength tuning vs. temperature		λ / T	0.3	0.3	0.3	nm/K
Wavelength tuning vs. operating current		λ / I	0.4	0.4	0.4	nm/A
Weight		m	ca. 8100	ca. 8100	ca. 8100	g
Output fiber (D80 connector on module)						
Core diameter of output fiber		d _{core}	400	400	600	µm
Fiber centricity			10	10	10	µm
Numerical aperture		NA	0.22	0.22	0.22	
Power monitor		PD	10-30	10-30	10-30	mV/W
Temperature sensor			LM35, NTC (10k) or PT100/1000 (please specify)			
Thermal resistance (bottom to temp. sensor)		R _{th}	0.013	0.013	0.013	K/W
Water temperature (recommended)		T	<17°	<15°	<15°	°C
Minimum water flux (industrial water, no DI-water)			2.5	3	3.5	l/min
Options						
Red pilot laser						
C.w. output power			1-3	1-3	1-3	mW
Peak wavelength			650 ± 15	650 ± 15	650 ± 15	nm
Operating voltage			3-5	3-5	3-5	V
Backreflection filter						
1064nm backreflection filter (35dB on request) (3)			18	18	18	dB
Fiber sensor						
Fiber sensor signal			12	12	12	V
Fiber sensor type PNP IFRM03P1503/Q (normally open) or with open collector output (please specify)						

Remarks:

*taken at internal temperature sensor

(1) Power is measured ex fiber according to given fiber specifications including precision and measures of fiber and ferrules for uncoated fiber facets

(2) narrower wavelength (+/- 4 nm) on request

(3) Back reflection is considered as 10ns pulse with 5% d.c. max. Back reflection filter which provides higher max. back reflection energy of 2 mJ is offered on request. Back reflection reduces power by 4% (18db), 8% (35db)

Rule of thumb: Power ex fiber decreases up to 2% every 10 °C temperature increase at internal temp. sensor, lifetime decreases by about factor of two every 10 °C

Calculation example of necessary water temperature for 100 W output power:

Thermal load = Output power * (1/conversion efficiency - 1), Water temperature = internal temperature - thermal load * Thermal resistance

Example: Output power: 100 W, Conversion efficiency: 0.2, Thermal resistance: 0.01 K/W, Internal temperature: 25 °C

Thermal load = 100 W * (1/0.2 - 1) = 400 W, Water temperature = 25 °C - 400 W * 0.01 K/W = 19 °C, (water flux must be adjusted accordingly)

Your ideas are welcome.

2

USA

Laser Components USA, Inc.
Tel: +1 603 821 – 7040
Fax: +1 603 821 – 7041
info@laser-components.com
www.laser-components.com

France

Laser Components S.A.S.
Tel: +33 1 39 59 52 25
Fax: +33 1 39 59 53 50
info@lasercomponents.fr
www.lasercomponents.fr

Absolute Maximum Ratings / General Informations

Parameter	Symbol	Min	Max	Unit
Storage temperature	T_{max}	0	+50	°C
Operating temp.* c.w.-operation**	$T_{op.c.w.}$	+15	+35	°C
Humidity / non condensing atmosphere			90	%
LD reverse voltage	V_R, max		10	V
Max fiber flange temperature			45	°C
Mounting screws / metric			M6	

Remarks:

- * taken at internal temperature sensor
- ** we recommend to operate the laser above dew point

User Safety

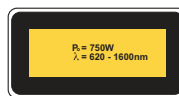
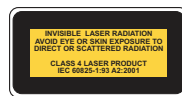

Important Note

Read and carefully follow operating manual instructions. Especially, whenever power supply is switched on or off, always disconnect from laser module. See manual for details. Uncontrolled on / off switching may cause spikes and result in fatal device damage.

Option fiber sensor signal:

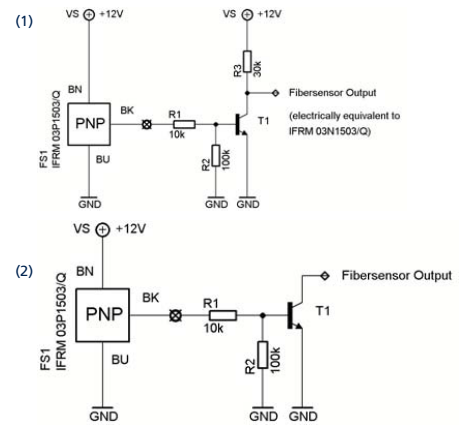

Your ideas are welcome.