

8-bit Proprietary Microcontroller

CMOS

F²MC-8L MB89480/MB89480L Series

MB89485/485L/P485/P485L/PV480

■ DESCRIPTION

The MB89480 series has been developed as a general-purpose version of the F²MC*-8L family consisting of proprietary 8-bit single-chip microcontrollers.

In addition to a compact instruction set, the microcontroller contains a variety of peripheral functions such as 21-bit timebase timer, watch prescaler, PWC timer, PWM timer, 8/16-bit timer/counter, 6-bit PPG, LCD controller/driver, external interrupt 1 (edge), external interrupt 2 (level), 10-bit A/D converter, UART/SIO, buzzer, watchdog timer reset.

The MB89480 series is designed suitable for LCD remote controller as well as in a wide range of applications for consumer product.

*: F²MC stands for FUJITSU Flexible Microcontroller.

■ FEATURES

- Package used
LQFP package and SH-DIP package for MB89P485/P485L, MB89485/485L
MDIP package and MQFP package for MB89PV480
- High speed operating capability at low voltage
- Minimum execution time: 0.32 μs at 12.5 MHz

(Continued)

■ PACKAGES

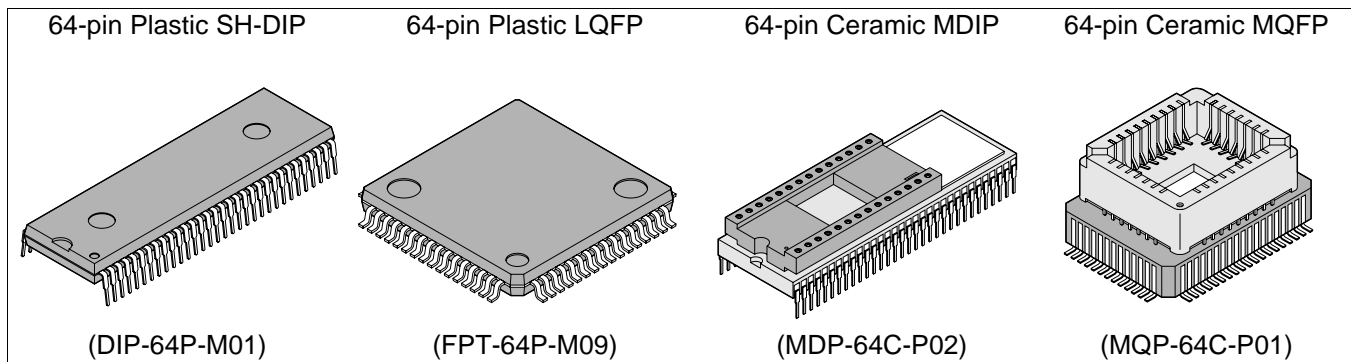

MB89480/480L Series

(Continued)

- F²MC-8L family CPU core

Instruction set optimized for controllers

}	Multiplication and division instructions
	16-bit arithmetic operations
	Test and branch instructions
	Bit manipulation instructions, etc.

- Six timers
 - PWC timer (also usable as an interval timer)
 - PWM timer
 - 8/16-bit timer/counter x 2
 - 21-bit timebase timer
 - Watch prescaler
- Programmable pulse generator
 - 6-bit PPG with program-selectable pulse width and period
- External interrupt
 - Edge detection (selectable edge) : 4 channels
 - Low level interrupt (wake-up function) : 8 channels
- A/D converter (4 channels)
 - 10-bit successive approximation type
- UART/SIO
 - Synchronous/asynchronous data transfer capability
- LCD controller/driver
 - Max 31 segments output x 4 commons
 - Booster for LCD driving (selected by mask option)
- Buzzer
 - 7 frequencies are selectable by software
- Low-power consumption mode
 - Stop mode (oscillation stops so as to minimize the current consumption.)
 - Sleep mode (CPU stops so as to reduce the current consumption to approx. 1/3 of normal.)
 - Watch mode (everything except the watch prescaler stops so as to reduce the power consumption to an extremely low level.)
 - Sub-clock mode
- Watchdog timer reset
- I/O ports: Max 42 channels

MB89480/480L Series

■ PRODUCT LINEUP

Part number Parameter	MB89485L	MB89485	MB89P485L	MB89P485	MB89PV480
Classification	Mass production products (mask ROM product)		OTP		Piggy-back
ROM size	16K x 8-bit (internal ROM)		16K x 8-bit (internal PROM with read protection) *2		32K x 8-bit (external ROM)*1
RAM size	512 x 8-bit				1K x 8-bit
CPU functions	Number of instructions : 136 Instruction bit length : 8 bits Instruction length : 1 to 3 bytes Data bit length : 1, 8, 16 bits Minimum execution time : 0.32 μs at 12.5 MHz Minimum interrupt processing time : 2.88 μs at 12.5 MHz				
Ports	I/O ports (CMOS) : 11 pins N-channel open drain I/O ports : 28 pins Output ports (N-channel open drain) : 2 pins Input port : 1 pin Total : 42 pins				
21-bit timebase timer	Interrupt period (0.66 ms, 2.6 ms, 21.0 ms, 335.5 ms) at 12.5 MHz.				
Watchdog timer	Reset period (167.8 ms to 335.5 ms) at 12.5 MHz.				
Pulse width count timer	1 channel. 8-bit one-shot timer operation (supports underflow output, operating clock period: 1, 4, 32 t_{inst} , external). 8-bit reload timer operation (supports square wave output, operating clock period: 1, 4, 32 t_{inst} , external). 8-bit pulse width measurement operation (supports continuous measurement, H width, L width, rising edge to rising edge, falling edge to falling edge measurement and both edge measurement).				
PWM timer	8-bit reload timer operation (supports square wave output, operating clock period: 1, 4, 32 t_{inst} , external). 8-bit resolution PWM operation.				
6-bit programmable pulse generator	Can generate square pulse with programmable period.				
8/16-bit timer/counter 11, 12	Can be operated either as a 2-channel 8-bit timer/counter (timer 11 and timer 12, each with its own independent operating clock cycle), or as one 16-bit timer/counter. In timer 11 or 16-bit timer/counter operation, event counter operation (external clock-triggered) and square wave output capability.				
8/16-bit timer/counter 21, 22	Can be operated either as a 2-channel 8-bit timer/counter (timer 21 and timer 22, each with its own independent operating clock cycle), or as one 16-bit timer/counter. In timer 21 or 16-bit timer/counter operation, event counter operation (external clock-triggered) and square wave output capability.				
External interrupt	4 independent channels (selectable edge, interrupt vector, request flag). 8 channels (low level interrupt).				

(Continued)

MB89480/480L Series

(Continued)

Part number Parameter	MB89485L	MB89485	MB89P485L	MB89P485	MB89PV480
A/D converter	10-bit resolution × 4 channels. A/D conversion function (conversion time: 60 t _{inst}). Supports repeated activation by internal clock.				
LCD controller/driver	Common output : 4 (Max) Segment output : 31 (Max) (selected resistor ladder) : 26 (Max) (selected booster) Bias power supply pins : 4 LCD display RAM size : 31 × 4 bits Dividing resistor/booster : selected by mask option				
UART/SIO	Synchronous/asynchronous data transfer capability. (Max baud rate: 97.656 Kbps at 12.5 MHz). (7 and 8 bits with parity bit; 8 and 9 bits without parity bit).				
Buzzer output	7 frequencies are selectable by software.				
Standby mode	Sleep mode, stop mode, watch mode, sub-clock mode.				
Process	CMOS				
Operating voltage	2.2 V to 3.6 V	2.2 V to 5.5 V	2.7 V to 3.6 V	3.5 V to 5.5 V	2.7 V to 5.5 V

*1 : Use MBM27C256A as the external ROM.

*2 : Read protection feature is selected by part number, detail please refer to MASK OPTIONS.

Note : 1 t_{inst} = one instruction cycle (execution time) which can be selected as 1/4, 1/8, 1/16, or 1/64 of main clock.

■ PACKAGE AND CORRESPONDING PRODUCTS

Part number Package	MB89485/485L	MB89P485/P485L	MB89PV480
DIP-64P-M01	O	O	X
FPT-64P-M09	O	O	X
MDP-64C-P02	X	X	O
MQP-64C-P01	X	X	O

O : Availabe

X : Not available

■ DIFFERENCES AMONG PRODUCTS

1. Memory Size

Before evaluating using the piggyback product, verify its differences from the product that will actually be used. Take particular care on the following point:

- The stack area is set at the upper limit of the RAM.

2. Current Consumption

- For the MB89PV480, the current consumed by the EPROM mounted in the piggy-back socket is needed to be included.
- When operating at low speed, the current consumed by the one-time PROM product is greater than that for the mask ROM product. However, the current consumption is roughly the same in sleep and stop mode.
- For more information, see “■ ELECTRICAL CHARACTERISTICS”.

3. Oscillation Stabilization Time after Power-on Reset

- For MB89PV480, MB89P485L and MB89485L, there is no power-on stabilization time after power-on reset.
- For MB89P485, there is power-on stabilization time after power-on reset.
- For MB89485, the power-on stabilization time can be selected.
- For more information, please refer to “■ MASK OPTION”.

MB89480/480L Series

PIN ASSIGNMENT

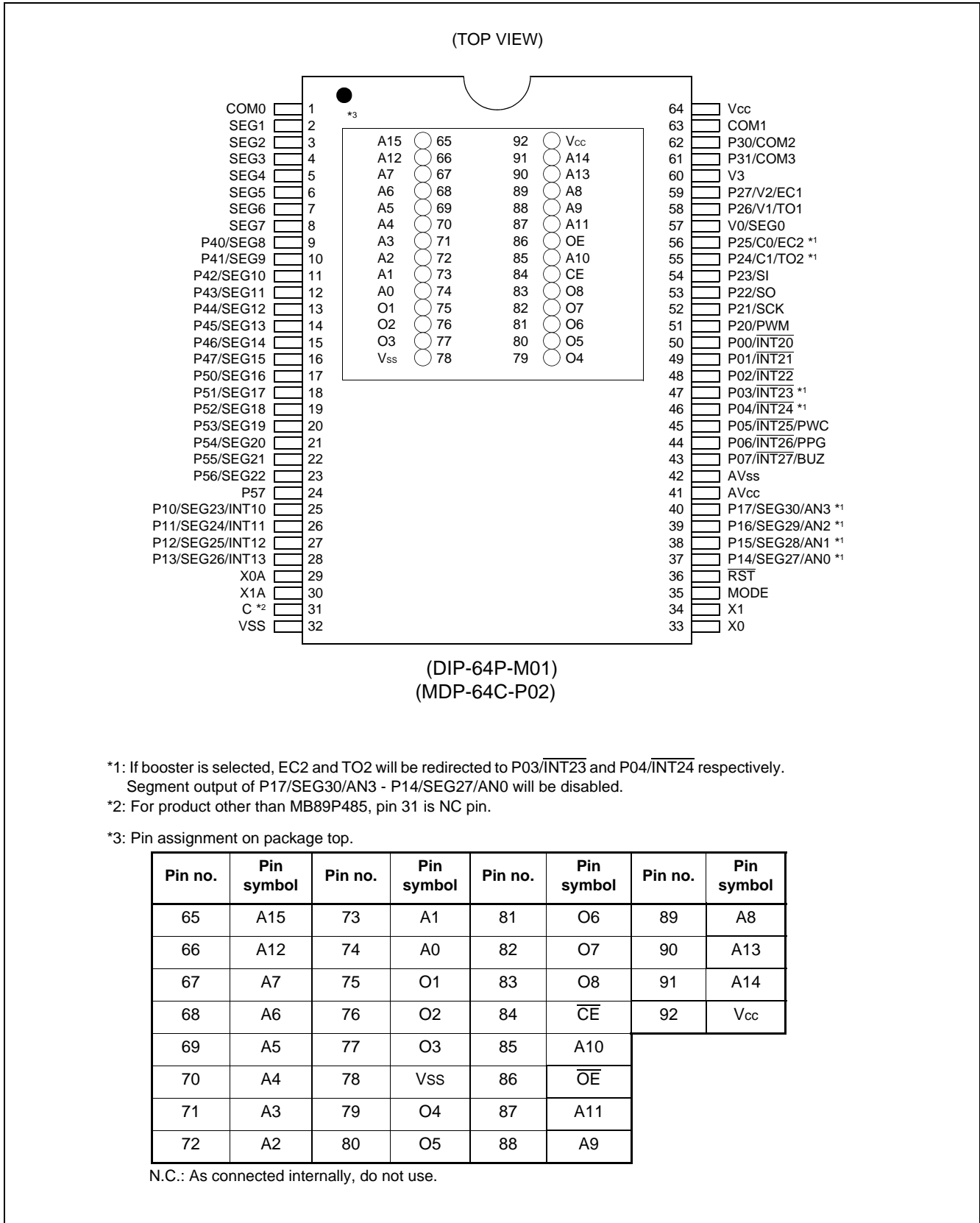

(Continued)

(TOP VIEW)

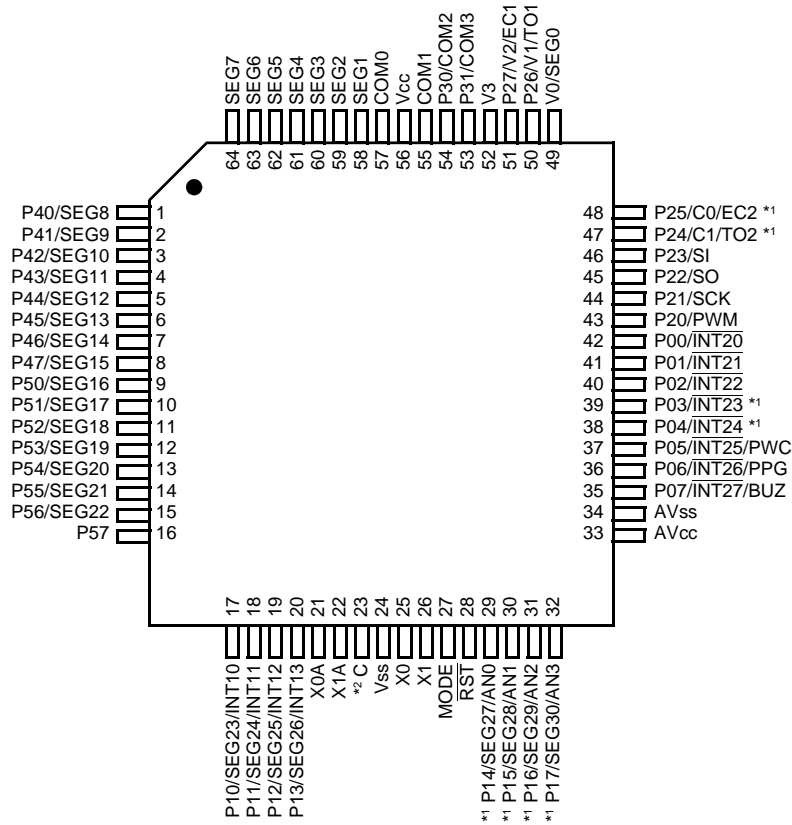

(FPT-64P-M09)

- *1: If booster is selected, EC2 and TO2 will be redirected to P03/INT23 and P04/INT24 respectively. Segment output of P17/SEG30/AN3 - P14/SEG27/AN0 will be disabled.
- *2: For product other than MB89P485, pin 23 is NC pin.

(Continued)

MB89480/480L Series

(Continued)

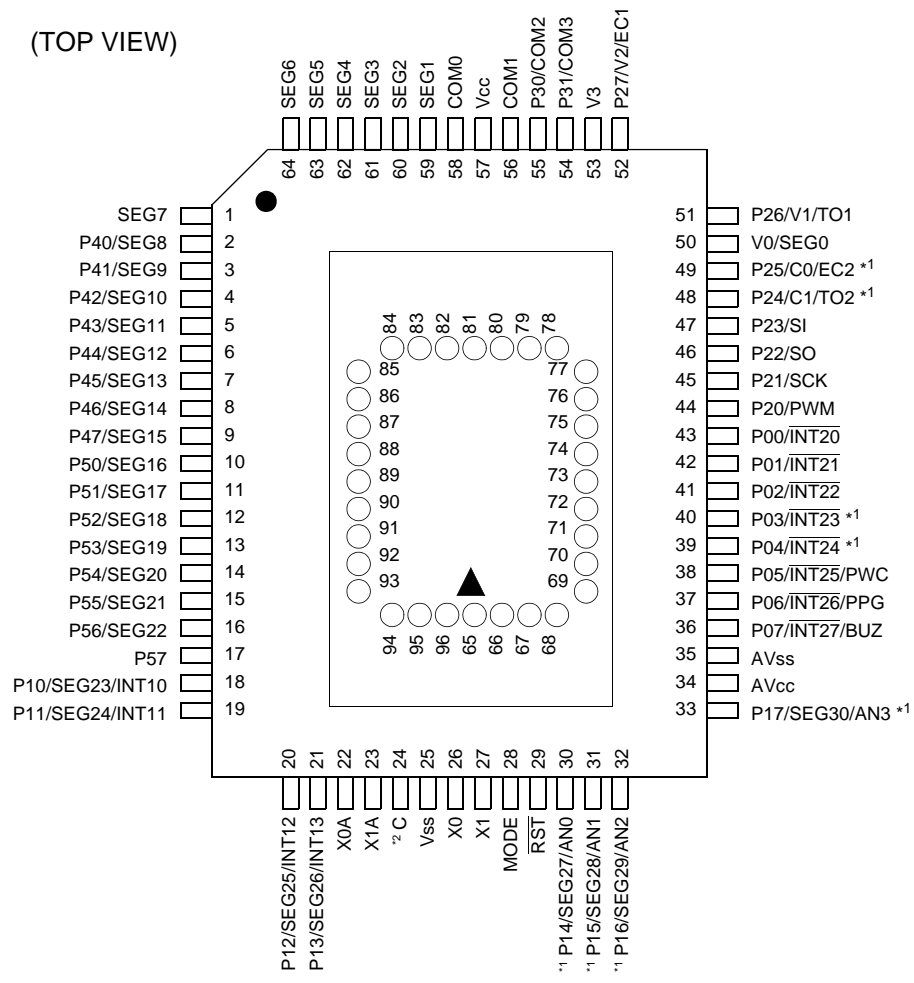

(MQP-64C-P01)

*1: If booster is selected, EC2 and TO2 will be redirected to P03/INT23 and P04/INT24 respectively.

Segment output of P17/SEG30/AN3 - P14/SEG27/AN0 will be disabled.

*2: Pin 24 is NC pin.

Pin assignment on package top

Pin no.	Pin symbol	Pin no.	Pin symbol	Pin no.	Pin symbol	Pin no.	Pin symbol
65	N.C.	73	A2	81	N.C.	89	$\overline{\text{OE}}$
66	V _{PP}	74	A1	82	O4	90	N.C.
67	A12	75	A0	83	O5	91	A11
68	A7	76	N.C.	84	O6	92	A9
69	A6	77	O1	85	O7	93	A8
70	A5	78	O2	86	O8	94	A13
71	A4	79	O3	87	$\overline{\text{CE}}$	95	A14
72	A3	80	V _{SS}	88	A10	96	V _{CC}

N.C.: As connected internally, do not use.

MB89480/480L Series

■ PIN DESCRIPTION

Pin number			Pin name	I/O circuit type	Function
SH-DIP*1 MDIP*4	MQFP*2	QFP*3			
33	26	25	X0	A	Connection pins for a crystal or other oscillator. An external clock can be connected to X0. In this case, leave X1 open.
34	27	26	X1		
29	22	21	X0A	A	Connection pins for a crystal or other oscillator. An external clock can be connected to X0A. In this case, leave X1A open.
30	23	22	X1A		
35	28	27	MODE	B	Input pin for setting the memory access mode. Connect directly to V _{SS} .
36	29	28	$\overline{\text{RST}}$	C	Reset I/O pin. The pin is an N-ch open-drain type with pull-up resistor and a hysteresis input. The pin outputs an "L" level when an internal reset request is present. Inputting an "L" level initializes internal circuits.
50 to 48	43 to 41	42 to 40	P00/ $\overline{\text{INT20}}$ to P02/ $\overline{\text{INT22}}$	D	General-purpose CMOS I/O port. A hysteresis input. The pin is shared with external interrupt 2 input.
47	40	39	P03/ $\overline{\text{INT23}}$	D	General-purpose CMOS I/O port. A hysteresis input. The pin is shared with external interrupt 2 input, and shared with 8/16-bit timer/counter 21, 22 input when booster is selected.
46	39	38	P04/ $\overline{\text{INT24}}$	D	General-purpose CMOS I/O port. A hysteresis input. The pin is shared with external interrupt 2 input, and shared with 8/16-bit timer/counter 21, 22 output when booster is selected.
45	38	37	P05/ $\overline{\text{INT25}}$ / PWC	D	General-purpose CMOS I/O port. A hysteresis input. The pin is shared with external interrupt 2 input, and PWC input.
44	37	36	P06/ $\overline{\text{INT26}}$ / PPG	D	General-purpose CMOS I/O port. A hysteresis input. The pin is shared with external interrupt 2 input, and 6-bit PPG output.
43	36	35	P07/ $\overline{\text{INT27}}$ / BUZ	D	General-purpose CMOS I/O port. A hysteresis input. The pin is shared with external interrupt 2 input and buzzer output.
25 to 28	18 to 21	17 to 20	P10/SEG23/ INT10 to P13/ SEG26/INT13	F/K	General-purpose N-ch open-drain I/O port. A hysteresis input. The pin is shared with external interrupt 1 input and LCD segment output.

(Continued)

MB89480/480L Series

Pin number			Pin name	I/O circuit type	Function
SH-DIP*1 MDIP*4	MQFP*2	QFP*3			
37 to 40	30 to 33	29 to 32	P14/SEG27/ AN0 to P17/ SEG30/AN3	G/K	General-purpose N-ch open-drain I/O port. An analog input. The pin is shared with A/D converter input and LCD segment output. LCD segment output will be disabled when booster is selected.
51	44	43	P20/PWM	E	General-purpose CMOS I/O port. The pin is shared with PWM output.
52	45	44	P21/SCK	E	General-purpose CMOS I/O port. The pin is shared with UART/SIO clock I/O.
53	46	45	P22/SO	E	General-purpose CMOS I/O port. The pin is shared with UART/SIO data output.
54	47	46	P23/SI	D	General-purpose CMOS I/O port. The pin is shared with UART/SIO data input.
55	48	47	P24/C1/TO2	H	General-purpose CMOS I/O port. The pin is shared with 8/16-bit timer 21, 22 output (it is redirected to P04/INT24 when booster is selected), and as a capacitor connecting pin when booster is selected.
56	49	48	P25/C0/EC2	F	General-purpose CMOS I/O port. A hysteresis input. The pin is shared with 8/16-bit timer 21, 22 input (it is redirected to P03/INT23 when booster is selected), and as a capacitor connecting pin when booster is selected.
58	51	50	P26/V1/TO1	H	General-purpose CMOS I/O port. The pin is shared with 8/16-bit timer 11, 12 output, and LCD power driving pin.
59	52	51	P27/V2/EC1	F	General-purpose CMOS I/O port. A hysteresis input. The pin is shared with 8/16-bit timer 11, 12 input, and LCD power driving pin.
62	55	54	P30/COM2	I / K	General-purpose N-ch open-drain output port. The pin is shared with the LCD common output.
61	54	53	P31/COM3	I / K	General-purpose N-ch open-drain output port. The pin is shared with the LCD common output.
9 to 16	2 to 9	1 to 8	P40/SEG8 to P47/SEG15	H / K	General-purpose N-ch open-drain I/O port. The pin is shared with LCD segment output.
17 to 23	10 to 16	9 to 15	P50/SEG16 to P56/SEG22	H / K	General-purpose N-ch open-drain I/O port. The pin is shared with LCD segment output.
24	17	16	P57	J	General-purpose CMOS input port.

(Continued)

MB89480/480L Series

(Continued)

Pin number			Pin name	I/O circuit type	Function
SH-DIP*1 MDIP*4	MQFP*2	QFP*3			
2 to 8	59 to 64, 1	58 to 64	SEG1 to SEG7	K	LCD segment output-only pins.
1, 63	58, 56	57, 55	COM0 to COM1	K	LCD common output-only pins.
60	53	52	V3	—	LCD driving power supply pin.
57	50	49	V0/SEG0	— / K	LCD driving power supply pin when booster is selected. LCD segment output when booster is not selected.
31	24	23	C	—	When MB89P485 is used, connect an external 0.1 μ F capacitor between this pin and the ground.
					N.C. pin when MB89485/485L, MB89P485L or MB89PV480 is used.
64	57	56	V _{CC}	—	Power supply pin (+3 V or +5 V).
32	25	24	V _{SS}	—	Power supply pin (GND).
41	34	33	AV _{CC}	—	A/D converter power supply pin.
42	35	34	AV _{SS}	—	A/D converter power supply pin. Use at the same voltage level as V _{SS} .

*1: DIP-64P-M01

*2: MQP-64C-P01

*3: FPT-64P-M09

*4: MDP-64C-P02

MB89480/480L Series

■ External EPROM Socket (MB89PV480 only)

Pin number		Pin name	I/O	Function
MDIP*1	MQFP*2			
91	95	A14	O	Address output pins.
90	94	A13		
66	67	A12		
87	91	A11		
85	88	A10		
88	92	A9		
89	93	A8		
67	68	A7		
68	69	A6		
69	70	A5		
70	71	A4		
71	72	A3		
72	73	A2		
73	74	A1		
74	75	A0		
83	86	O8	I	Data input pins.
82	85	O7		
81	84	O6		
80	83	O5		
79	82	O4		
77	79	O3		
76	78	O2		
75	77	O1		
65	65	N.C.	—	Internally connected pins. Always leave open.
76	76			
81	81			
90	90			
65	66	V _{PP}	O	"H" level output pin.
78	80	V _{SS}	O	Power supply pin (GND).
84	87	\overline{CE}	O	Chip enable pin for the EPROM. Outputs "H" in standby mode.
86	89	OE	O	Output enable pin for the EPROM. Always outputs "L".
92	96	V _{CC}	O	Power supply pin for the EPROM.

*1: MDP-64C-P02

*2: MQP-64C-P01

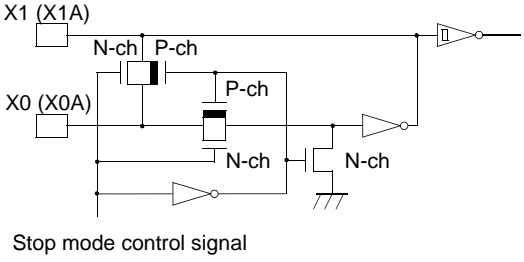
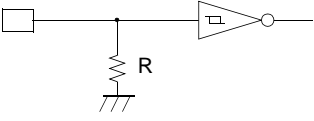
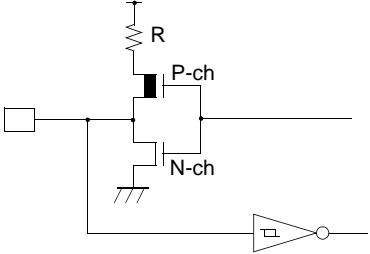
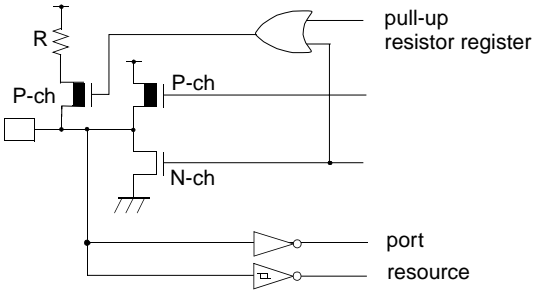
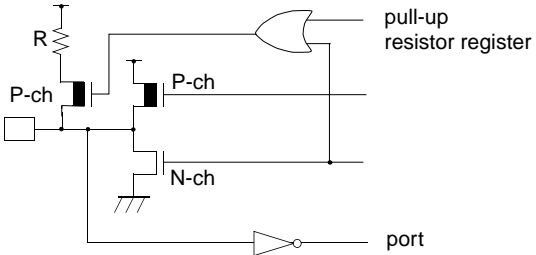

I/O CIRCUIT TYPE

Type	Circuit	Remarks
A	 <p>X1 (X1A) X0 (X0A) N-ch P-ch N-ch P-ch N-ch N-ch Stop mode control signal</p>	<ul style="list-style-type: none"> • Main/Sub-clock circuit • Oscillation feedback resistance is approx. 500 kΩ for main clock circuit and 5 MΩ for sub-clock circuit.
B	 <p>R</p>	<ul style="list-style-type: none"> • Hysteresis input • The pull-down resistor (not available in MB89P485/P485L) Approx. 50 kΩ
C	 <p>R P-ch N-ch</p>	<ul style="list-style-type: none"> • The pull-up resistor (P-channel) Approx. 50 kΩ • Hysteresis input
D	 <p>R P-ch P-ch N-ch pull-up resistor register port resource</p>	<ul style="list-style-type: none"> • CMOS output • CMOS input • Hysteresis input • Selectable pull-up resistor Approx. 50 kΩ
E	 <p>R P-ch P-ch N-ch pull-up resistor register port</p>	<ul style="list-style-type: none"> • CMOS output • CMOS input • Selectable pull-up resistor Approx. 50 kΩ

(Continued)

MB89480/480L Series

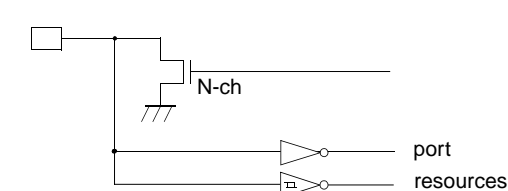
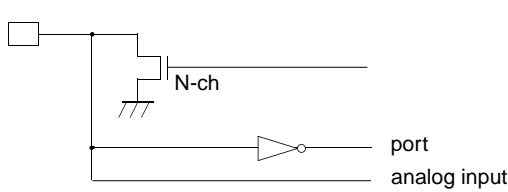
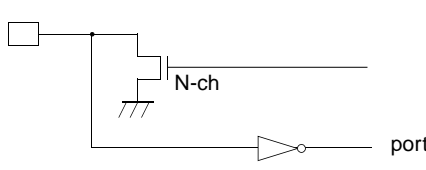
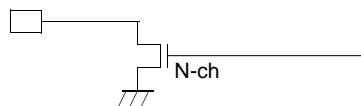
(Continued)

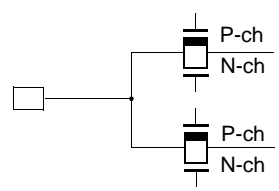
Type	Circuit	Remarks
F		<ul style="list-style-type: none"> • N-ch open-drain output • CMOS input • Hysteresis input
G		<ul style="list-style-type: none"> • N-ch open-drain output • CMOS input • Analog input
H		<ul style="list-style-type: none"> • N-ch open-drain output • CMOS input
I		<ul style="list-style-type: none"> • N-ch open-drain output
J		<ul style="list-style-type: none"> • CMOS input
K		<ul style="list-style-type: none"> • LCD segment output

■ HANDLING DEVICES

1. Preventing Latch-up

Latch-up may occur on CMOS IC if voltage higher than V_{CC} or lower than V_{SS} is applied to input and output pins other than medium- to high-voltage pins or if higher than the voltage which shows on “1. Absolute Maximum Ratings” in ■ ELECTRICAL CHARACTERISTICS is applied between V_{CC} and V_{SS} .

When latch-up occurs, power supply current increases rapidly and might thermally damage elements. When using, take great care not to exceed the absolute maximum ratings.

Also, take care to prevent the analog power supply (AV_{CC}) and analog input from exceeding the digital power supply (V_{CC}) when the analog system power supply is turned on and off.

2. Treatment of Unused Input Pins

Leaving unused input pins open could cause malfunctions. They should be connected to a pull-up or pull-down resistor.

3. Treatment of Power Supply Pins on Microcontrollers with A/D Converter

Connect to be $AV_{CC} = V_{CC}$ and $AV_{SS} = V_{SS}$ even if the A/D converter is not in use.

4. Treatment of N.C. Pins

Be sure to leave (internally connected) N.C. pins open.

5. Power Supply Voltage Fluctuations

Although V_{CC} power supply voltage is assured to operate within the rated range, a rapid fluctuation of the voltage could cause malfunctions, even if it occurs within the rated range. Stabilizing voltage supplied to the IC is therefore important. As stabilization guidelines, it is recommended to control power so that V_{CC} ripple fluctuations (P-P value) will be less than 10% of the standard V_{CC} value at the commercial frequency (50 to 60 Hz) and the transient fluctuation rate will be less than 0.1 V/ms at the time of a momentary fluctuation such as when power is switched.

6. Precautions when Using an External Clock

Even when an external clock is used, oscillation stabilization time is required for power-on reset and wake-up from stop mode.

7. Notes on noise in the External Reset Pin (\overline{RST})

If the reset pulse applied to the external reset pin (\overline{RST}) does not meet the specifications, it may cause malfunctions. Use caution so that the reset pulse less than the specifications will not be fed to the external reset pin (\overline{RST}).

MB89480/480L Series

■ PROGRAMMING OTPROM IN MB89P485/P485L WITH SERIAL PROGRAMMER

1. Programming the OTPROM with Serial Programmer

- All OTP products can be programmed with serial programmer.

2. Programming the OTPROM

- To program the OTPROM using FUJITSU MICROELECTRONICS MCU programmer MB91919-001.

Inquiry : Fujitsu Microelectronics Asia Pte Ltd. :TEL (65)-2810770
FAX (65)-2810220

3. Programming Adapter for OTPROM

- To program the OTPROM using FUJITSU MICROELECTRONICS MCU programmer MB91919-001, use the programming adapter listed below.

Package	Compatible socket adapter
DIP-64P-M01	MB91919-812
FPT-64P-M09	MB91919-813

Inquiry : Fujitsu Microelectronics Asia Pte Ltd. : TEL (65)-2810770
FAX (65)-2810220

4. OTPROM Content Protection

For product with OTPROM content protection feature (MB89P485/P485L-103, MB89P485/P485L-104), OTPROM content can be read using serial programmer if the OTPROM content protection mechanism is not activated.

One predefined area of the OTPROM (FFFC_H) is assigned to be used for preventing the read access of OTPROM content. If the protection code "00_H" is written in this address (FFFC_H), the OTPROM content cannot be read by any serial programmer.

Note: The program written into the OTPROM cannot be verified once the OTPROM protection code is written ("00_H" in FFC_H). It is advised to write the OTPROM protection code at last.

5. Programming Yield

All bits cannot be programmed at FUJITSU MICROELECTRONICS shipping test to a blanked OTPROM micro-computer, due to its nature. For this reason, a programming yield of 100% cannot be assured at all times.

■ PROGRAMMING OTPROM IN MB89P485/P485L WITH PARALLEL PROGRAMMER

1. Programming OTPROM with Parallel Programmer

- Only products without protection feature (i.e. MB89P485/P485L-101 and MB89P485/P485L-102) can be programmed with parallel programmer. Product with protection feature (i.e. MB89P485/P485L-103 and MB89P485/P485L-104) cannot be programmed with parallel programmer.

2. ROM Writer Adapters and Recommended ROM Writers

- The following shows ROM writer adapters and recommended ROM writers.

Ando Electric Co., Ltd. (Parallel programmer)

Package name	Applicable adapter model	Recommended writer
DIP-64P-M01	ROM2-64SD-32DP-8LA2	AF9708*
FPT-64P-M09	ROM2-64QF2-32DP-8LA3	AF9709*
		AF9723*

* : For the programmer and the version of the programmer, contact the Flash Support Group, Inc.

Fujitsu Microelectronics Asia Pte Ltd. (Serial programmer)

Package name	Applicable adapter model	Recommended writer
DIP-64P-M01	MB91919-604	MB91919-001
FPT-64P-M09	MB91919-605	

Inquiries : Fujitsu Microelectronics Asia Pte Ltd. : TEL (65)-2810770
 Sunhayato Corp. : TEL 81-(3)-3986-7791
 : FAX 81-(3)-3971-0535
 E-mail : adapter@sunhayato.co.jp
 Flash Support Group, Inc : FAX 81-(53)-428-8377
 E-mail : support@j-fsg.co.jp

3. Writing Data to the OTPROM using Writer from Minato Electronics Co., Ltd.

- (1) Set the OTPROM writer for the CU50-OTP (device code: cdB6DC).
- (2) Load the program data to the OTPROM writer.
- (3) Write data using the OTPROM writer.

4. Programming Yield

All bits cannot be programmed at FUJITSU MICROELECTRONICS shipping test to a blanked OTPROM micro-computer, due to its nature. For this reason, a programming yield of 100% cannot be assured at all times.

MB89480/480L Series

■ PROGRAMMING TO THE EPROM WITH PIGGYBACK/EVALUATION DEVICE

1. EPROM for Use

MBM27C256A-20TVM

2. Programming Socket Adapter

To program to the PROM using an EPROM programmer, use the socket adapter (manufacturer: Sun Hayato Co., Ltd.) listed below.

Package	Adapter socket part number
LCC-32 (Rectangle)	ROM-32LC-28DP-S

Inquiry: Sun Hayato Co., Ltd.: TEL 81-3-3986-0403

3. Memory Space

Memory space in each mode is shown in the diagram below.

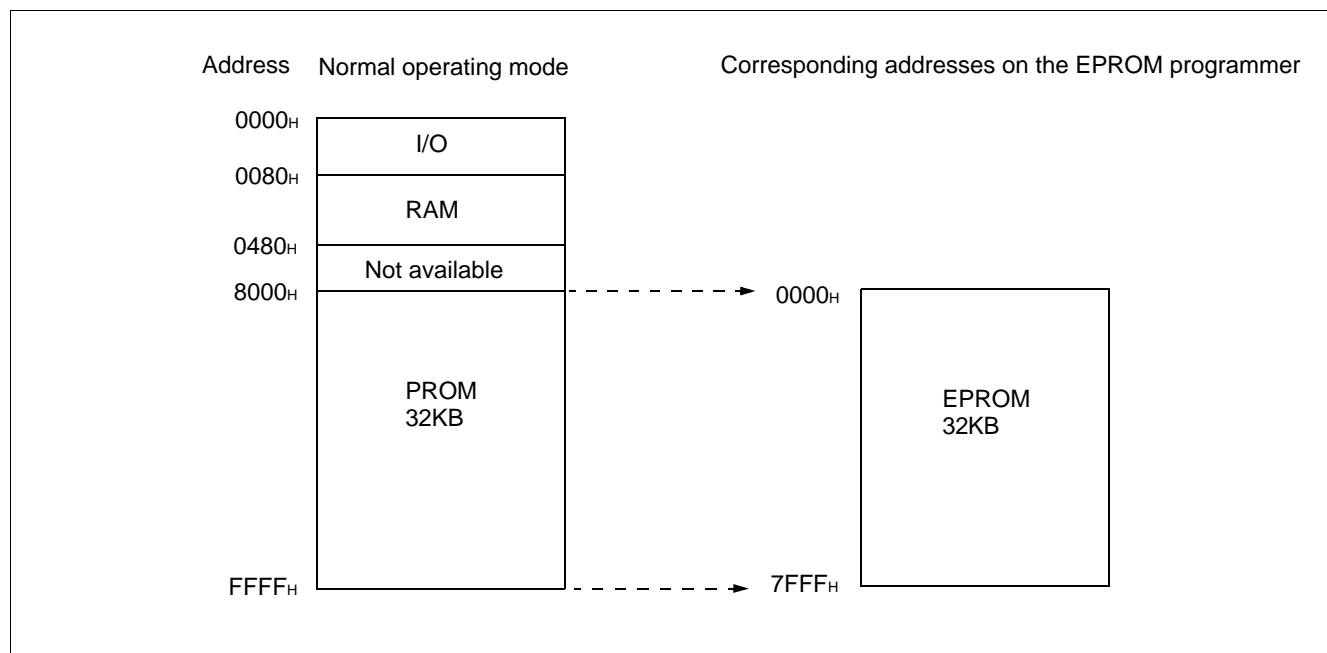

4. Programming to the EPROM

- (1) Set the EPROM programmer to the MBM27C256.
- (2) Load program data into the EPROM programmer at 0000H to 7FFFH.
- (3) Program to 0000H to 7FFFH with the EPROM programmer.

■ BLOCK DIAGRAM

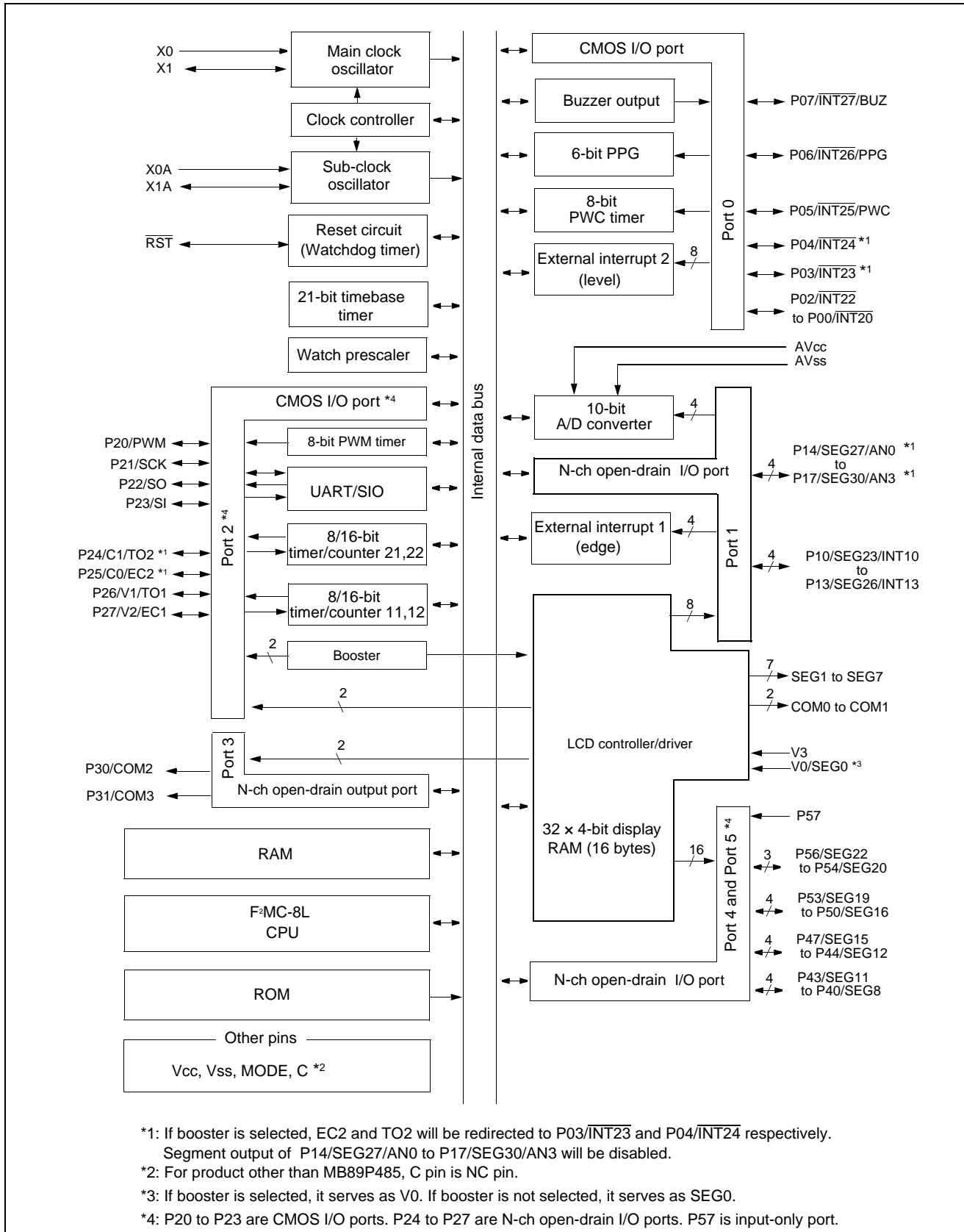

MB89480/480L Series

■ CPU CORE

1. Memory Space

The microcontrollers of the MB89480 series offer a memory space of 64 Kbytes for storing all of I/O, data, and program areas. The I/O area is located the lowest address. The data area is provided immediately above the I/O area. The data area can be divided into register, stack, and direct areas according to the application. The program area is located at exactly the opposite end, that is, near the highest address. Provide the tables of interrupt reset vectors and vector call instructions toward the highest address within the program area. The memory space of the MB89480 series is structured as illustrated below.

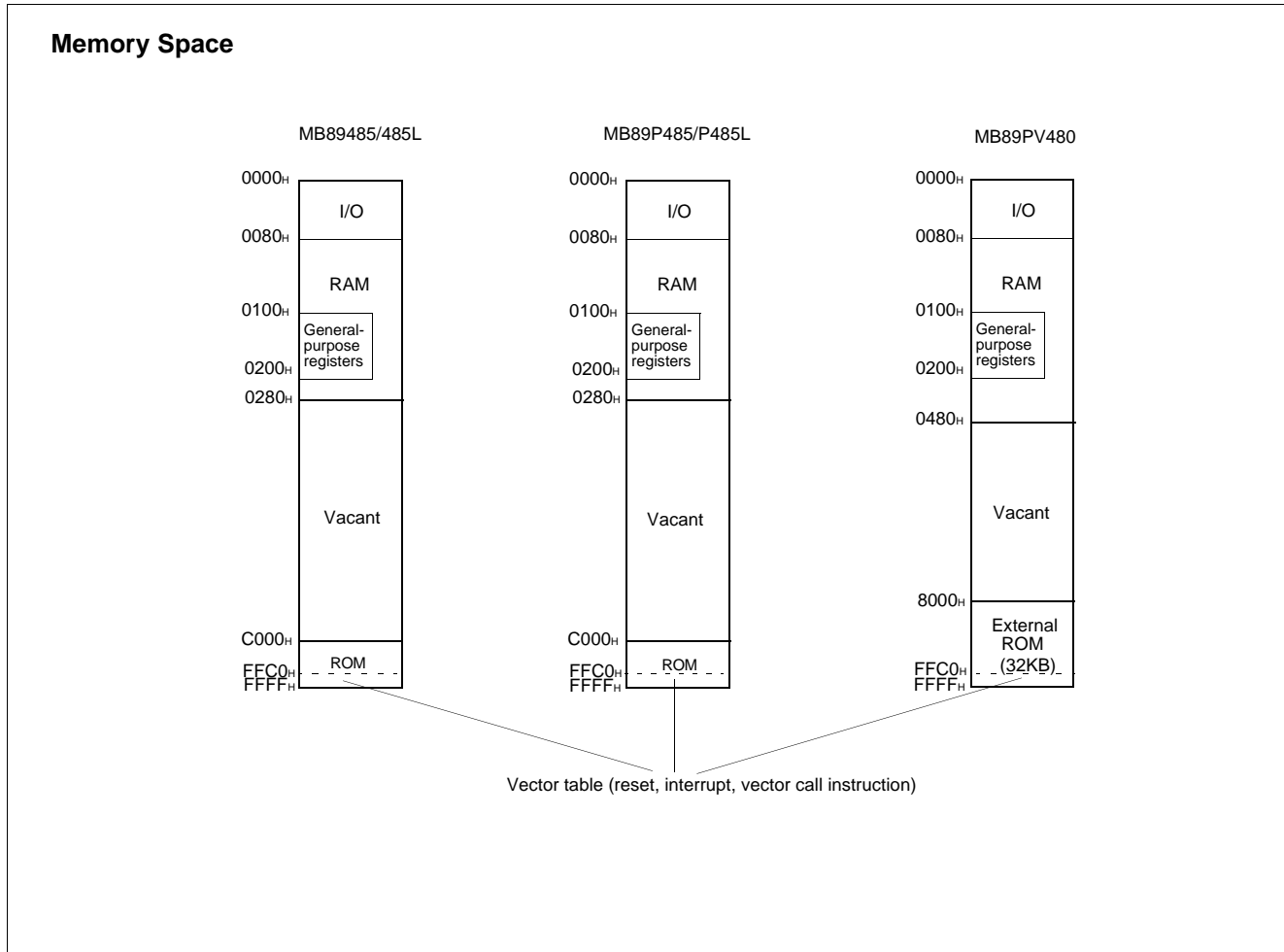

2. Registers

The F²MC-8L family has two types of registers; dedicated registers in the CPU and general-purpose registers in the memory. The following registers are provided:

- Program counter (PC) : A 16-bit register for indicating instruction storage positions.
- Accumulator (A) : A 16-bit temporary register for storing arithmetic operations, etc. When the instruction is an 8-bit data processing instruction, the lower byte is used.
- Temporary accumulator (T) : A 16-bit register for performing arithmetic operations with the accumulator. When the instruction is an 8-bit data processing instruction, the lower byte is used.
- Index register (IX) : A 16-bit register for index modification.
- Extra pointer (EP) : A 16-bit pointer for indicating a memory address.
- Stack pointer (SP) : A 16-bit register for indicating a stack area.
- Program status (PS) : A 16-bit register for storing a register pointer, a condition code.

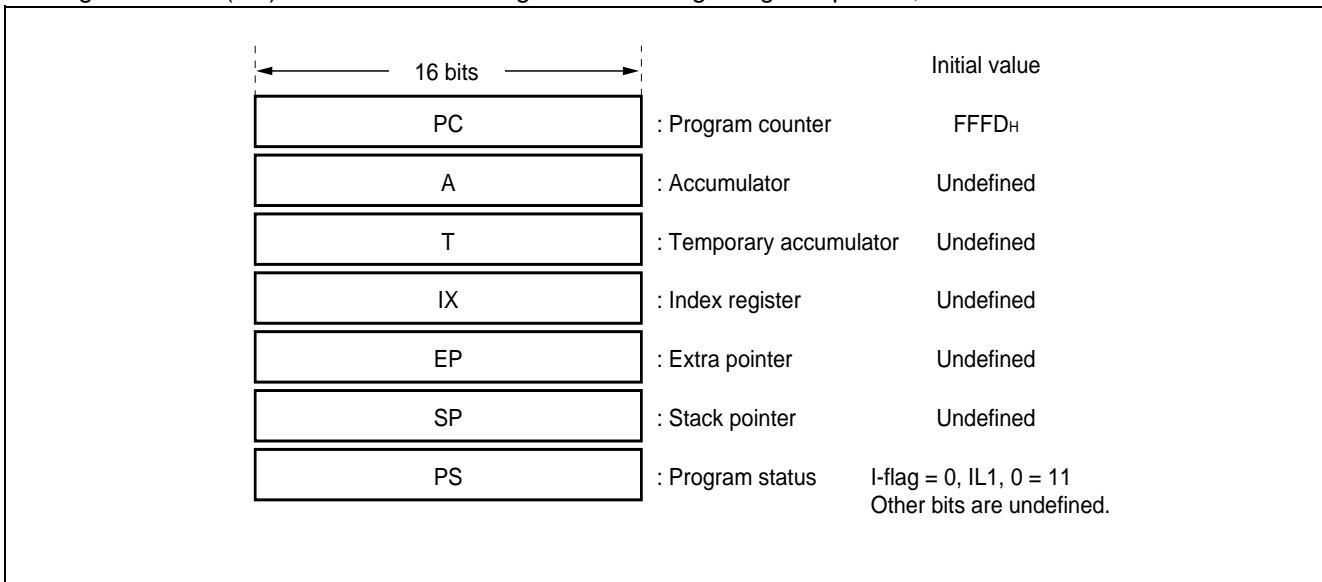

The PS can further be divided into higher 8 bits for use as a register bank pointer (RP) and the lower 8 bits for use as a condition code register (CCR). (See the diagram below.)

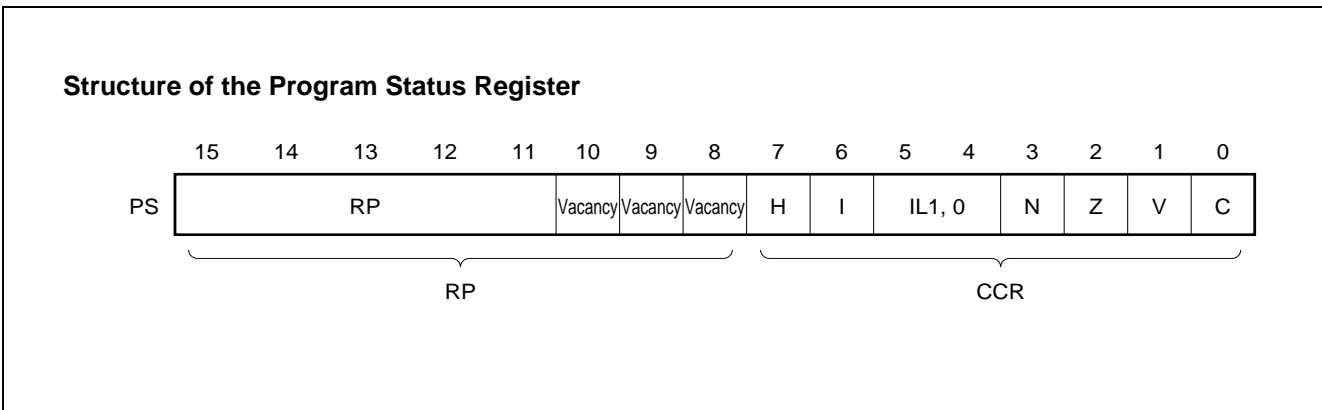

MB89480/480L Series

The RP indicates the address of the register bank currently in use. The relationship between the pointer contents and the actual address is based on the conversion rule illustrated below.

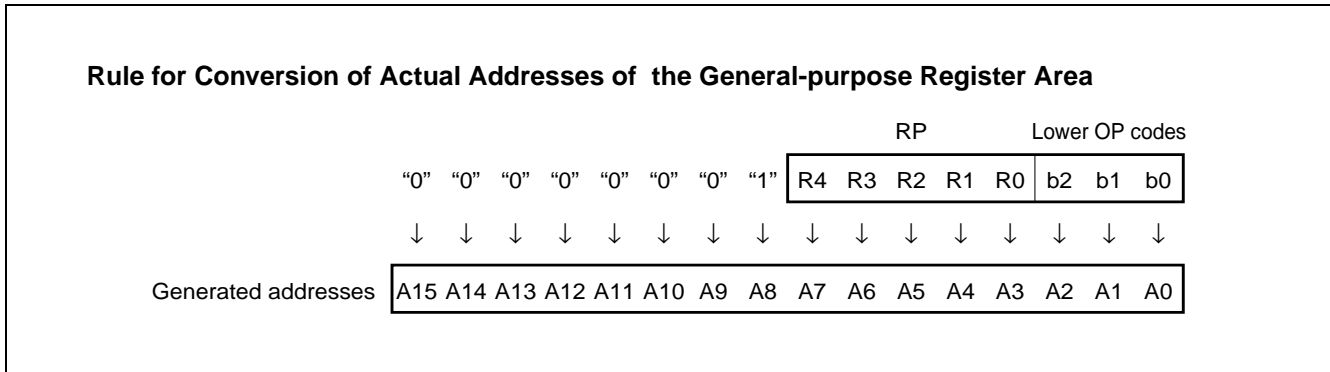

The CCR consists of bits indicating the results of arithmetic operations and the contents of transfer data and bits for control of CPU operations at the time of an interrupt.

- H-flag : Set to "1" when a carry or a borrow from bit 3 to bit 4 occurs as a result of an arithmetic operation. Clear to "0" otherwise. This flag is for decimal adjustment instructions.
- I-flag : Interrupt is allowed when this flag is set to "1". Interrupt is prohibited when the flag is set to "0". Clear to "0" when reset.
- IL1, 0 : Indicates the level of the interrupt currently allowed. Processes an interrupt only if its request level is higher than the value indicated by this bit.

IL1	ILO	Interrupt level	Priority
0	0	1	High ↑ ↓ Low = no interrupt
0	1		
1	0	2	
1	1	3	

- N-flag : Set to "1" if the MSB is set to "1" as the result of an arithmetic operation. Clear to "0" otherwise.
- Z-flag : Set to "1" when an arithmetic operation results in "0". Clear to "0" otherwise.
- V-flag : Set to "1" if a signed numeric value overflows because of an arithmetic calculation. Clear to "0" if the overflow does not occur.
- C-flag : Set to "1" when a carry or a borrow from bit 7 occurs as a result of an arithmetic operation. Clear to "0" otherwise. Set to the shift-out value in the case of a shift instruction.

MB89480/480L Series

The following general-purpose registers are provided:

General-purpose registers: An 8-bit register for storing data

The general-purpose registers are 8 bits and located in the register banks of the memory. One bank contains eight registers. Up to a total of 32 banks can be used on the MB89480 series. The bank currently in use is indicated by the register bank pointer (RP).

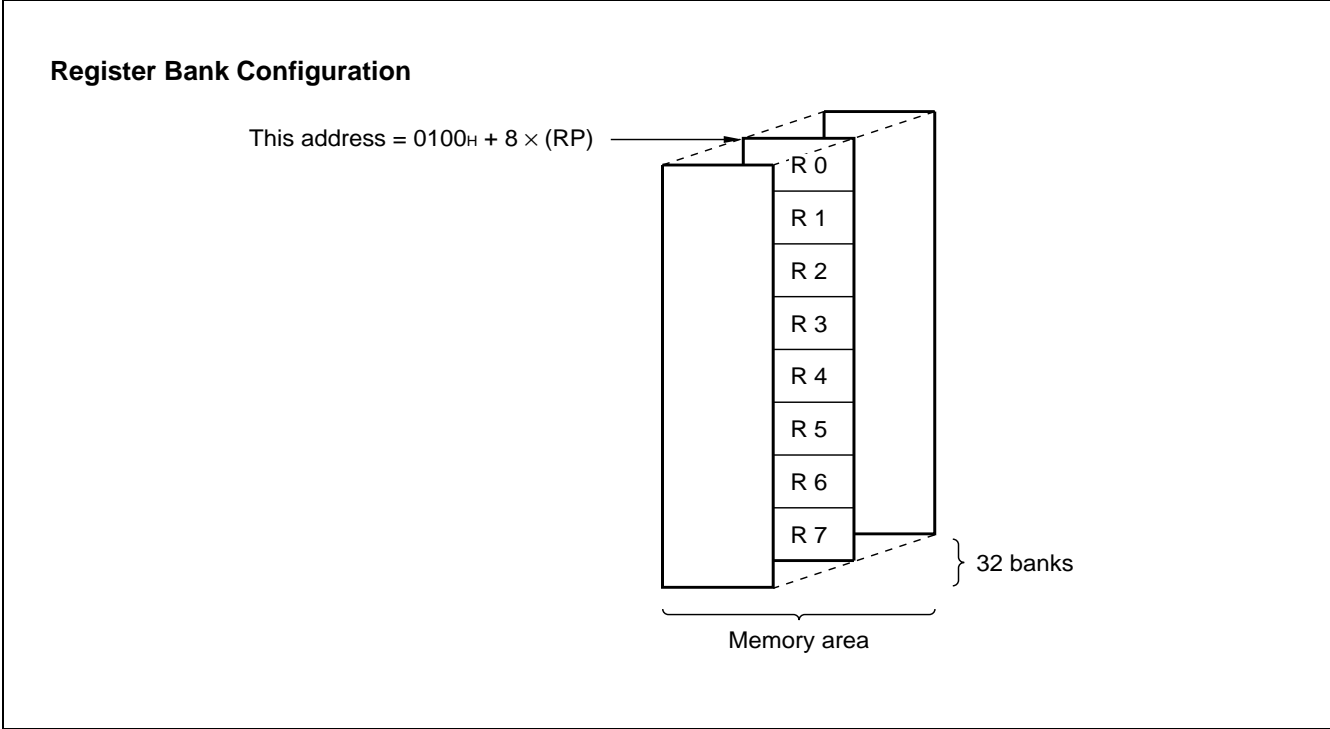

MB89480/480L Series

■ I/O MAP

Address	Register name	Register description	Read/Write	Initial value
00 _H	PDR0	Port 0 data register	R/W	XXXXXXXX _B
01 _H	DDR0	Port 0 data direction register	W*	00000000 _B
02 _H	PDR1	Port 1 data register	R/W	XXXXXXXX _B
03 _H	DDR1	Port 1 data direction register	W*	00000000 _B
04 _H	PDR2	Port 2 data register	R/W	00000000 _B
05 _H	(Reserved)			
06 _H	DDR2	Port 2 data direction register	R/W	00000000 _B
07 _H	SYCC	System clock control register	R/W	X-1MM100 _B
08 _H	STBC	Standby control register	R/W	00010XXX _B
09 _H	WDTC	Watchdog timer control register	W*	0---XXXX _B
0A _H	TBTC	Timebase timer control register	R/W	00---000 _B
0B _H	WPCR	Watch prescaler control register	R/W	00--0000 _B
0C _H	PDR3	Port 3 data register	R/W	-----11 _B
0D _H	(Reserved)			
0E _H	RSFR	Reset flag register	R	XXXX---- _B
0F _H	(Reserved)			
10 _H	PDR4	Port 4 data register	R/W	11111111 _B
11 _H	(Reserved)			
12 _H	PDR5	Port 5 data register	R/W	X1111111 _B
13 _H to 1F _H	(Reserved)			
20 _H	SMC1	UART/SIO mode control register 1	R/W	00000000 _B
21 _H	SMC2	UART/SIO mode control register 2	R/W	00000000 _B
22 _H	SRC	UART/SIO rate control register	R/W	XXXXXXXX _B
23 _H	SSD	UART/SIO status/data register	R	00001--- _B
24 _H	SIDR/SODR	UART/SIO data register	R/W	XXXXXXXX _B
25 _H	EIC1	External interrupt 1 control register 1	R/W	00000000 _B
26 _H	EIC2	External interrupt 1 control register 2	R/W	00000000 _B
27 _H	EIE2	External interrupt 2 enable register	R/W	00000000 _B
28 _H	EIF2	External interrupt 2 flag register	R/W	-----0 _B
29 _H to 2B _H	(Reserved)			
2C _H	ADC1	A/D control register 1	R/W	-0000000 _B
2D _H	ADC2	A/D control register 2	R/W	-0000001 _B
2E _H	ADDH	A/D data register (Upper byte)	R	-----XX _B
2F _H	ADDL	A/D data register (Lower byte)	R	XXXXXXXX _B
30 _H	ADEN	A/D input enable register	R/W	1111---- _B
31 _H	PCR1	PWC control register 1	R/W	0-0--000 _B
32 _H	PCR2	PWC control register 2	R/W	00000000 _B
33 _H	PLBR	PWC reload buffer register	R/W	XXXXXXXX _B

(Continued)

MB89480/480L Series

(Continued)

Address	Register name	Register description	Read/Write	Initial value
34 _H	CNTR	PWM timer control register	R/W	0-000000 _B
35 _H	COMR	PWM timer compare register	W*	XXXXXXXX _B
36 _H	T22CR	Timer 22 control register	R/W	000000X0 _B
37 _H	T21CR	Timer 21 control register	R/W	000000X0 _B
38 _H	T22DR	Timer 22 data register	R/W	XXXXXXXX _B
39 _H	T21DR	Timer 21 data register	R/W	XXXXXXXX _B
3A _H	T12CR	Timer 12 control register	R/W	000000X0 _B
3B _H	T11CR	Timer 11 control register	R/W	000000X0 _B
3C _H	T12DR	Timer 12 data register	R/W	XXXXXXXX _B
3D _H	T11DR	Timer 11 data register	R/W	XXXXXXXX _B
3E _H	PPGC1	PPG control register 1	R/W	00000000 _B
3F _H	PPGC2	PPG control register 2	R/W	0-000000 _B
40 _H	BUZR	Buzzer control register	R/W	-----000 _B
41 _H to 5D _H	(Reserved)			
5E _H	LCR1	LCD controller control register 1	R/W	00010000 _B
5F _H	LCR2	LCD controller control register 2	R/W	-0000000 _B
60 _H to 6F _H	VRAM	LCD data RAM	R/W	XXXXXXXX _B
70 _H	PURC0	Port 0 pull up resistor control register	R/W	11111111 _B
71 _H	(Reserved)			
72 _H	PURC2	Port 2 pull up resistor control register	R/W	----1111 _B
73 _H to 7A _H	(Reserved)			
7B _H	ILR1	Interrupt level setting register 1	W*	11111111 _B
7C _H	ILR2	Interrupt level setting register 2	W*	11111111 _B
7D _H	ILR3	Interrupt level setting register 3	W*	11111111 _B
7E _H	ILR4	Interrupt level setting register 4	W*	11111111 _B
7F _H	(Reserved)			

* : Bit manipulation instruction cannot be used.

- **Read/write access symbols**

R/W : Readable and writable

R : Read-only

W : Write-only

- **Initial value symbols**

0 : The initial value of this bit is "0".

1 : The initial value of this bit is "1".

X : The initial value of this bit is undefined.

- : Unused bit.

M : The initial value of this bit is determined by mask option.

MB89480/480L Series

■ ELECTRICAL CHARACTERISTICS

1. Absolute Maximum Ratings

($AV_{SS} = V_{SS} = 0.0\text{ V}$)

Parameter	Symbol	Value		Unit	Remarks
		Min	Max		
Power supply voltage	V_{CC} AV_{CC}	$V_{SS} - 0.3$	$V_{SS} + 6.0$	V	MB89PV480, MB89P485, MB89485 AV_{CC} must not exceed V_{CC}
	V_{CC} AV_{CC}	$V_{SS} - 0.3$	$V_{SS} + 4.0$	V	MB89P485L, MB89485L AV_{CC} must not exceed V_{CC}
LCD power supply voltage	V0 to V3	$V_{SS} - 0.3$	$V_{SS} + 6.0$	V	
Input voltage	V_i	$V_{SS} - 0.3$	$V_{CC} + 0.3$	V	P00 to P07, P10 to P17, P20 to P27, P40 to P47, P50 to P57
Output voltage	V_o	$V_{SS} - 0.3$	$V_{CC} + 0.3$	V	P00 to P07, P10 to P17, P20 to P27, P30 to P31, P40 to P47, P50 to P56
Maximum clamp current	I_{CLAMP}	-2.0	+2.0	mA	*
Total maximum clamp current	$\sum I_{CLAMP} $	—	20	mA	*
“L” level maximum output current	I_{OL}	—	15	mA	
“L” level average output current	I_{OLAV}	—	4	mA	Average value (operating current × operating rate)
“L” level total maximum output current	$\sum I_{OL}$	—	100	mA	
“L” level total average output current	$\sum I_{OLAV}$	—	40	mA	Average value (operating current × operating rate)
“H” level maximum output current	I_{OH}	—	-15	mA	
“H” level average output current	I_{OHAV}	—	-4	mA	Average value (operating current × operating rate)
“H” level total maximum output current	$\sum I_{OH}$	—	-50	mA	
“H” level total average output current	$\sum I_{OHAV}$	—	-20	mA	Average value (operating current × operating rate)
Power consumption	P_D	—	300	mW	
Operating temperature	T_A	-40	+85	°C	
Storage temperature	T_{stg}	-55	+150	°C	

Precautions: Permanent device damage may occur if the above “Absolute Maximum Ratings” are exceeded. Functional operation should be restricted to the conditions as detailed in the operational sections of this data sheet. Exposure to absolute maximum rating conditions for extended periods may affect device reliability.

- * :
- Applicable to pins: P00 to P07, P20 to P23, AN0 to AN3
 - Use within recommended operating conditions.
 - Use at DC voltage (current).
 - The +B signal should always be applied with a limiting resistance placed between the +B signal and the microcontroller.
 - The value of the limiting resistance should be set so that when the +B signal is applied the input current to the microcontroller pin does not exceed rated values, either instantaneously or for prolonged periods.

MB89480/480L Series

- Note that when the microcontroller drive current is low, such as in the power saving modes, the +B input potential may pass through the protective diode and increase the potential at the V_{cc} pin, and this may affect other devices.
- Note that if a +B signal is input when the microcontroller current is off (not fixed at 0 V), the power supply is provided from the pins, so that incomplete operation may result.
- Note that if the +B input is applied during power-on, the power supply is provided from the pins and the resulting supply voltage may not be sufficient to operate the power-on result.
- Care must be taken not to leave the +B input pin open.
- Note that analog system input/output pins other than the A/D input pins (LCD drive pins, comparator input pins, etc.) cannot accept +B signal input.
- Sample recommended circuits :

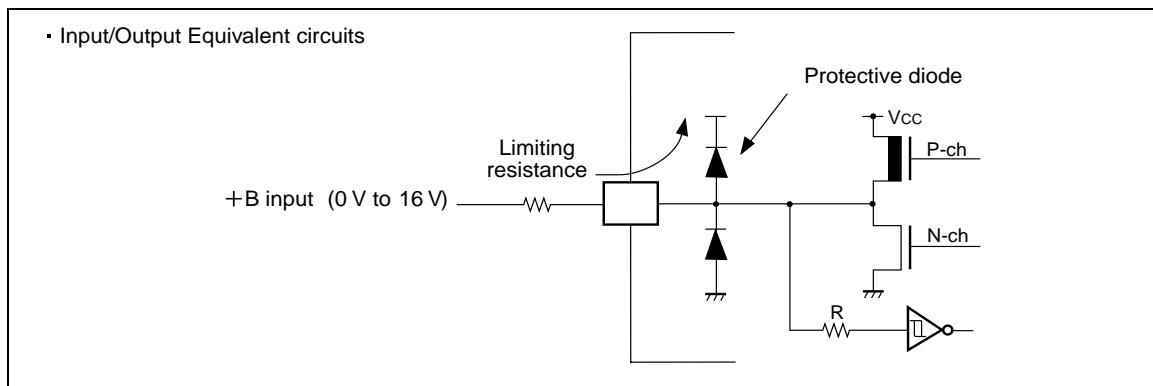

WARNING: Semiconductor devices can be permanently damaged by application of stress (voltage, current, temperature, etc.) in excess of absolute maximum ratings. Do not exceed these ratings.

2. Recommended Operating Conditions

(AV_{ss} = V_{ss} = 0.0 V)

Parameter	Symbol	Value		Unit	Remarks	
		Min	Max			
Power supply voltage	V _{cc} AV _{cc}	2.2*	5.5	V	Operation assurance range	MB89485
		3.5*	5.5	V	Operation assurance range	MB89P485
		2.7*	5.5	V	Operation assurance range	MB89PV480
		1.5	5.5	V	Retains the RAM state in stop mode	MB89485, MB89P485, MB89PV480
		2.2*	3.6	V	Operation assurance range	MB89485L, MB89P485L
		1.5	3.6	V	Retains the RAM state in stop mode	
LCD power supply voltage	V0 to V3	V _{ss}	V _{cc}	V		
Operating temperature	T _A	-40	+85	°C		

MB89480/480L Series

* : These values depend on the operating conditions and the analog assurance range. See Figure 1, 2, 3 and "5. A/D Converter Electrical Characteristics."

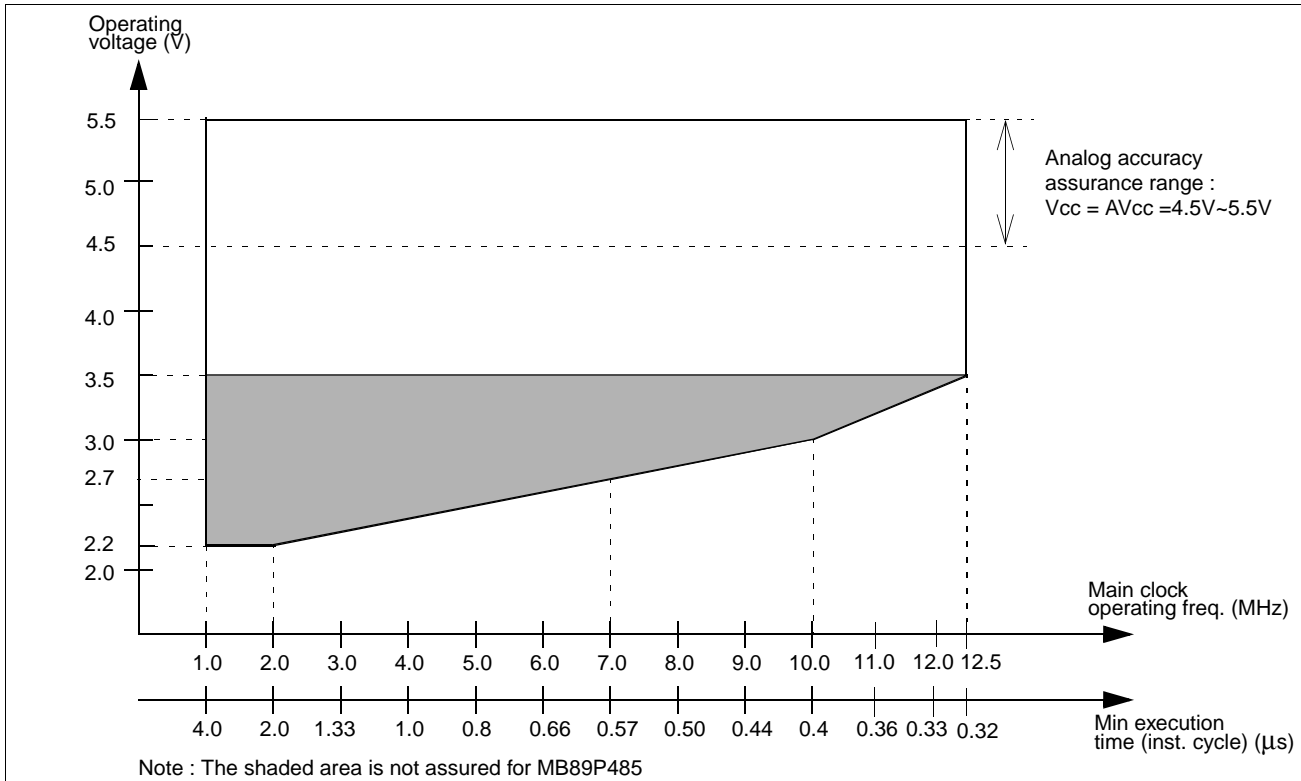

Figure 1 Operating Voltage vs. Main Clock Operating Frequency (MB89P485/485)

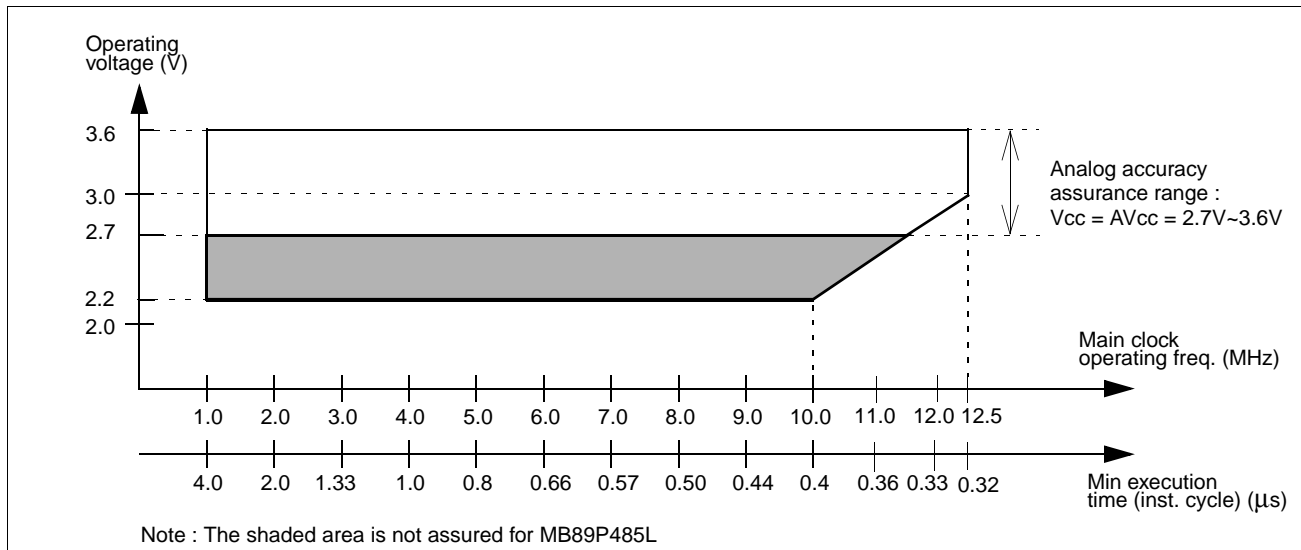

Figure 2 Operating Voltage vs. Main Clock Operating Frequency (MB89P485L/485L)

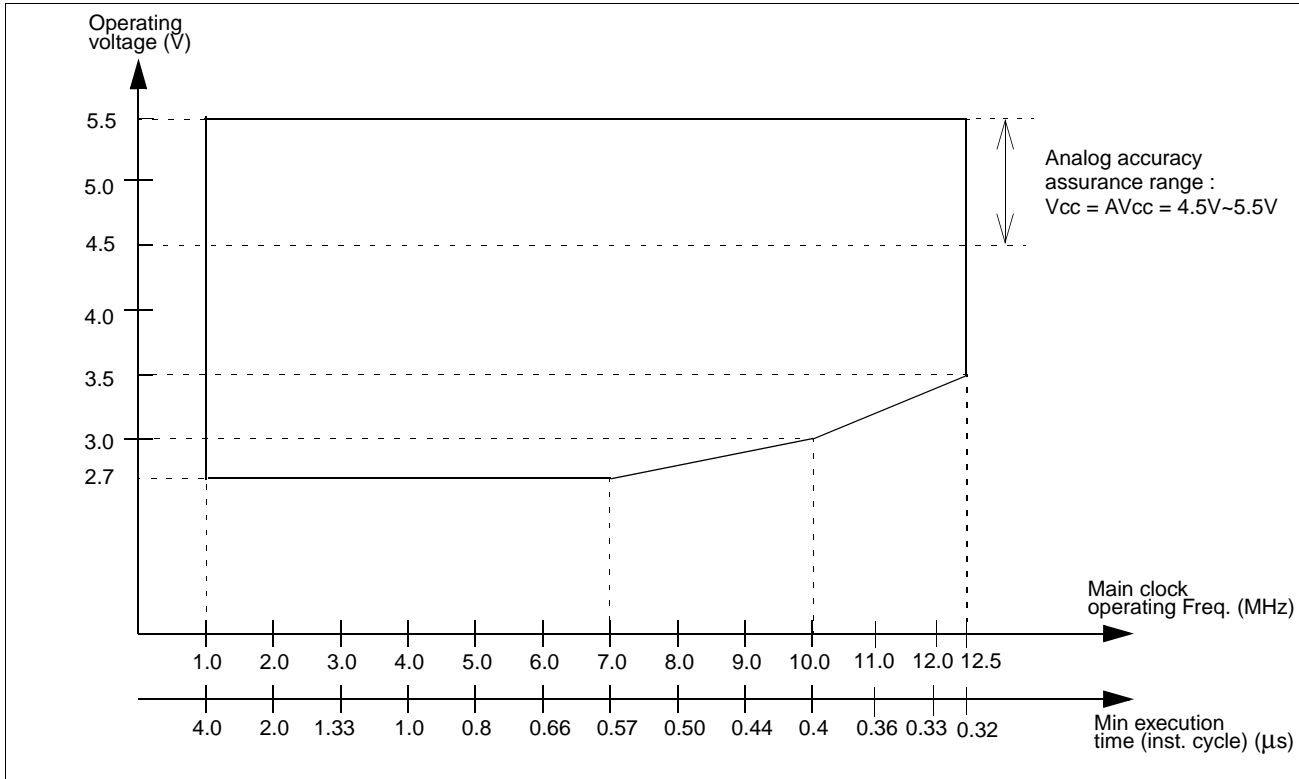

Figure 3 Operating Voltage vs. Main Clock Operating Frequency (MB89PV480)

Figure 1, 2 and 3 indicate the operating frequency of the external oscillator at an instruction cycle of $4/F_{CH}$.

Since the operating voltage range is dependent on the instruction cycle, see minimum execution time if the operating speed is switched using a gear.

WARNING: The recommended operating conditions are required in order to ensure the normal operation of the semiconductor device. All of the device's electrical characteristics are warranted when the device is operated within these ranges.

Always use semiconductor devices within their recommended operating condition ranges. Operation outside these ranges may adversely affect reliability and could result in device failure.

No warranty is made with respect to uses, operating conditions, or combinations not represented on the data sheet. Users considering application outside the listed conditions are advised to contact their representatives beforehand.

MB89480/480L Series

3. DC Characteristics

($AV_{CC} = V_{CC} = 5.0\text{ V}$ for MB89PV480, MB89P485, MB89485, $AV_{SS} = V_{SS} = 0.0\text{ V}$, $T_A = -40^\circ\text{C}$ to $+85^\circ\text{C}$)

$AV_{CC} = V_{CC} = 3.0\text{ V}$ for MB89P485L, MB89485L, $AV_{SS} = V_{SS} = 0.0\text{ V}$, $T_A = -40^\circ\text{C}$ to $+85^\circ\text{C}$)

Parameter	Symbol	Pin	Condition	Value			Unit	Remarks
				Min	Typ	Max		
“H” level input voltage	V_{IH}	P00 to P07, P10 to P17, P20 to P27, P40 to P47, P50 to P57	—	$0.7 V_{CC}$	—	$V_{CC} + 0.3$	V	
	V_{IHS}	\overline{RST} , MODE, EC1, EC2, PWC, SCK, SI, INT10 to INT13, INT20 to INT27	—	$0.8 V_{CC}$	—	$V_{CC} + 0.3$	V	
“L” level input voltage	V_{IL}	P00 to P07, P10 to P17, P20 to P27, P40 to P47, P50 to P57	—	$V_{SS} - 0.3$	—	$0.3 V_{CC}$	V	
	V_{ILS}	\overline{RST} , MODE, EC1, EC2, PWC, SCK, SI, INT10 to INT13, INT20 to INT27	—	$V_{SS} - 0.3$	—	$0.2 V_{CC}$	V	
Open-drain output pin application voltage	V_D	P10 to P17, P24 to P27, P30 to P31, P40 to P47, P50 to P56	—	$V_{SS} - 0.3$	—	$V_{CC} + 0.3$	V	Product without booster
						V3		Product with booster
“H” level output voltage	V_{OH}	P00 to P07, P20 to P23	$I_{OH} = -2.0\text{ mA}$	4.0	—	—	V	MB89PV480, MB89P485, MB89485
				2.2	—	—	V	MB89P485L, MB89485L
“L” level output voltage	V_{OL}	P00 to P07, P10 to P17, P20 to P27, P30 to P31, P40 to P47, P50 to P56, \overline{RST}	$I_{OL} = 4.0\text{ mA}$	—	—	0.4	V	MB89PV480, MB89P485, MB89485
		P00 to P07, P20 to P23, \overline{RST}		—	—	0.4	V	MB89P485L, MB89485L
		P10 to P17, P24 to P27, P30 to P31, P40 to P47, P50 to P56	$I_{OL} = 2.0\text{ mA}$	—	—	0.4	V	MB89P485L, MB89485L

(Continued)

MB89480/480L Series

(Continued)

($AV_{CC} = V_{CC} = 5.0\text{ V}$ for MB89PV480, MB89P485, MB89485, $AV_{SS} = V_{SS} = 0.0\text{ V}$, $T_A = -40^\circ\text{C}$ to $+85^\circ\text{C}$)
 $AV_{CC} = V_{CC} = 3.0\text{ V}$ for MB89P485L, MB89485L, $AV_{SS} = V_{SS} = 0.0\text{ V}$, $T_A = -40^\circ\text{C}$ to $+85^\circ\text{C}$)

Parameter	Symbol	Pin	Condition	Value			Unit	Remarks
				Min	Typ	Max		
Input leakage current	I_{LI}	P00 to P07, P10 to P17, P20 to P27, P40 to P47, P50 to P57	$0.45\text{ V} < V_I < V_{CC}$	-5	—	+5	μA	Without pull-up resistor
Open-drain output leakage current	I_{LOD}	P10 to P17, P24 to P27, P30 to P31, P40 to P47, P50 to P56	$0.45\text{ V} < V_I < V_{CC}$	-5	—	+5	μA	
Pull-down resistance	R_{DOWN}	MODE	$V_I = V_{CC}$	25	50	100	$\text{k}\Omega$	Except MB89P485, MB89P485L
Pull-up resistance	R_{PULL}	P00 to P07, P20 to P23, $\overline{\text{RST}}$	$V_I = 0.0\text{ V}$	25	50	100	$\text{k}\Omega$	When pull-up resistor is selected (except $\overline{\text{RST}}$)
Power supply current	I_{CC1}	V_{CC}	$F_{CH} = 10\text{ MHz}$, $t_{inst} = 0.4\ \mu\text{s}$, Main clock run mode	—	6	13	mA	MB89485
				—	3	7		MB89485L
				—	5	10		MB89P485
				—	4	8		MB89P485L
	I_{CC2}		$F_{CH} = 10\text{ MHz}$, $t_{inst} = 6.4\ \mu\text{s}$, Main clock run mode	—	0.9	3	mA	MB89485
				—	0.4	1.5		MB89485L
				—	0.9	3		MB89P485
				—	0.5	2		MB89P485L
	I_{CCS1}		$F_{CH} = 10\text{ MHz}$, $t_{inst} = 0.4\ \mu\text{s}$, Main clock sleep mode	—	2	5	mA	MB89485
				—	1	2.5		MB89485L
				—	2.5	5		MB89P485
				—	1.2	2.5		MB89P485L
	I_{CCS2}		$F_{CH} = 10\text{ MHz}$, $t_{inst} = 6.4\ \mu\text{s}$, Main clock sleep mode	—	0.7	2	mA	MB89485
				—	0.3	1		MB89485L
				—	0.9	2		MB89P485
				—	0.4	1		MB89P485L
	I_{CCL}		$F_{CL} = 32.768\text{ kHz}$, $T_A = +25^\circ\text{C}$, Sub-clock run mode	—	40	85	μA	MB89485
				—	22	50		MB89485L
				—	400	800		MB89P485
				—	25	50		MB89P485L

(Continued)

MB89480/480L Series

($AV_{CC} = V_{CC} = 5.0\text{ V}$ for MB89PV480, MB89P485, MB89485, $AV_{SS} = V_{SS} = 0.0\text{ V}$, $T_A = -40^\circ\text{C}$ to $+85^\circ\text{C}$)
 $AV_{CC} = V_{CC} = 3.0\text{ V}$ for MB89P485L, MB89485L, $AV_{SS} = V_{SS} = 0.0\text{ V}$, $T_A = -40^\circ\text{C}$ to $+85^\circ\text{C}$)

Parameter	Symbol	Pin	Condition	Value			Unit	Remarks
				Min	Typ	Max		
Power supply current	I _{CCLS}	V _{CC}	F _{CL} = 32.768 kHz, T _A = +25°C, Sub-clock sleep mode	—	15	30	μA	MB89485
				—	7	15		MB89485L
				—	12	30		MB89P485
				—	7	15		MB89P485L
	I _{CCT}		T _A = +25°C, Watch mode, Main clock stop mode	—	2	10	μA	MB89485
				—	1	5		MB89485L
				—	5	15		MB89P485
				—	1	5		MB89P485L
	I _{CCH}	T _A = +25°C, Sub-clock stop mode	—	1	5	μA	MB89485	
			—	0.8	4		MB89485L	
			—	3	10		MB89P485	
			—	0.8	4		MB89P485L	
	I _A	AV _{CC}	A/D conversion active	—	1.3	6	mA	MB89485
				—	1	3		MB89485L
				—	1.3	6		MB89P485
				—	1	3		MB89P485L
	I _{AH}		T _A = +25°C, A/D conversion stop	—	1	5	μA	MB89485
				—	0.8	4		MB89485L
				—	1	5		MB89P485
				—	0.8	4		MB89P485L
Common output impedance	R _{VCOM}	COM0 to COM3	V1 to V3 = +3.0 V	—	—	2.5	kΩ	MB89P485L, MB89485L
			V1 to V3 = +5.0 V					MB89PV480, MB89P485, MB89485
Segment output impedance	R _{VSEG}	SEG0 to SEG30	V1 to V3 = +3.0 V	—	—	15	kΩ	MB89P485L, MB89485L
			V1 to V3 = +5.0 V					MB89PV480, MB89P485, MB89485
LCD divided resistance	R _{LCD}	—	Between V _{CC} and V _{SS}	300	500	750	kΩ	

(Continued)

MB89480/480L Series

(Continued)

($AV_{CC} = V_{CC} = 5.0\text{ V}$ for MB89PV480, MB89P485, MB89485, $AV_{SS} = V_{SS} = 0.0\text{ V}$, $T_A = -40^\circ\text{C}$ to $+85^\circ\text{C}$)
 $AV_{CC} = V_{CC} = 3.0\text{ V}$ for MB89P485L, MB89485L, $AV_{SS} = V_{SS} = 0.0\text{ V}$, $T_A = -40^\circ\text{C}$ to $+85^\circ\text{C}$)

Parameter	Symbol	Pin	Condition	Value			Unit	Remarks
				Min	Typ	Max		
LCD controller/driver leakage current	I_{LCDL}	V0 to V3, COM0 to COM3, SEG0 to SEG30	—	—	—	± 1	μA	
Booster for LCD driving output voltage	V_{V3}	V3	$V1 = 1.5\text{ V}$	4.3	4.5	4.7	V	Products with booster only
	V_{V2}	V2	$V1 = 1.5\text{ V}$	2.9	3.0	3.1	V	
Reference input voltage for LCD driving	V_{V1}	V1	$I_{IN} = 0.0\ \mu\text{A}$	1.4	1.5	1.7	V	
Reference voltage input impedance	R_{RIN}	V1	—	8.5	9.8	11	$\text{k}\Omega$	
Input capacitance	C_{IN}	Other than V_{CC} , V_{SS} , AV_{CC} , AV_{SS}	$f = 1\text{ MHz}$	—	5	15	pF	

MB89480/480L Series

4. AC Characteristics

(1) Reset Timing

($AV_{CC} = V_{CC} = 5.0\text{ V}$ for MB89PV480, MB89P485, MB89485, $AV_{SS} = V_{SS} = 0.0\text{ V}$, $T_A = -40^\circ\text{C}$ to $+85^\circ\text{C}$)
 $AV_{CC} = V_{CC} = 3.0\text{ V}$ for MB89P485L, MB89485L, $AV_{SS} = V_{SS} = 0.0\text{ V}$, $T_A = -40^\circ\text{C}$ to $+85^\circ\text{C}$)

Parameter	Symbol	Condition	Value		Unit	Remarks
			Min	Max		
$\overline{\text{RST}}$ "L" pulse width	t_{ZLZH}	—	48 t_{HCYL}	—	ns	

Note : t_{HCYL} is the oscillation cycle ($1/F_{\text{CH}}$) to input to the X0 pin.

The MCU operation is not guaranteed when the "L" pulse width is shorter than t_{ZLZH} .

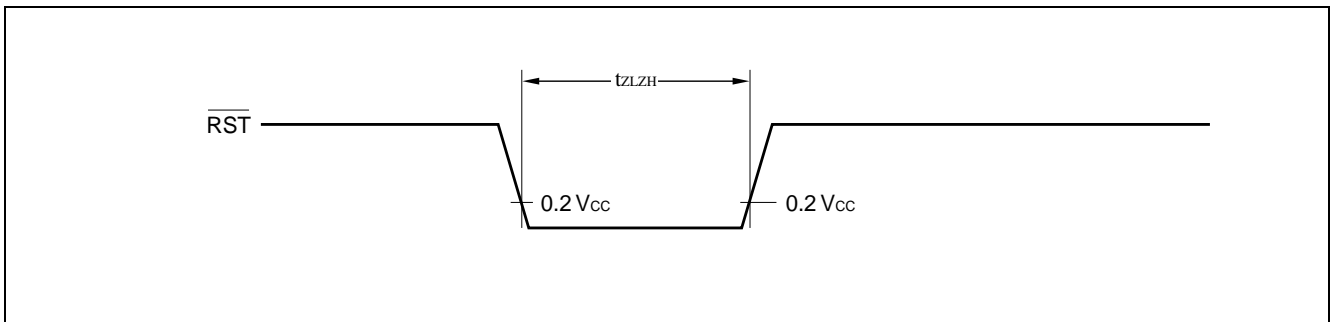

(2) Power-on Reset

($AV_{SS} = V_{SS} = 0.0\text{ V}$, $T_A = -40^\circ\text{C}$ to $+85^\circ\text{C}$)

Parameter	Symbol	Condition	Value		Unit	Remarks
			Min	Max		
Power supply rising time	t_{R}	—	—	50	ms	
Power supply cut-off time	t_{OFF}	—	1	—	ms	Due to repeated operations

Note : Make sure that power supply rises within the selected oscillation stabilization time.

Rapid changes in power supply voltage may cause a power-on reset. If power supply voltage needs to be varied in the course of operation, a smooth voltage rise is recommended.

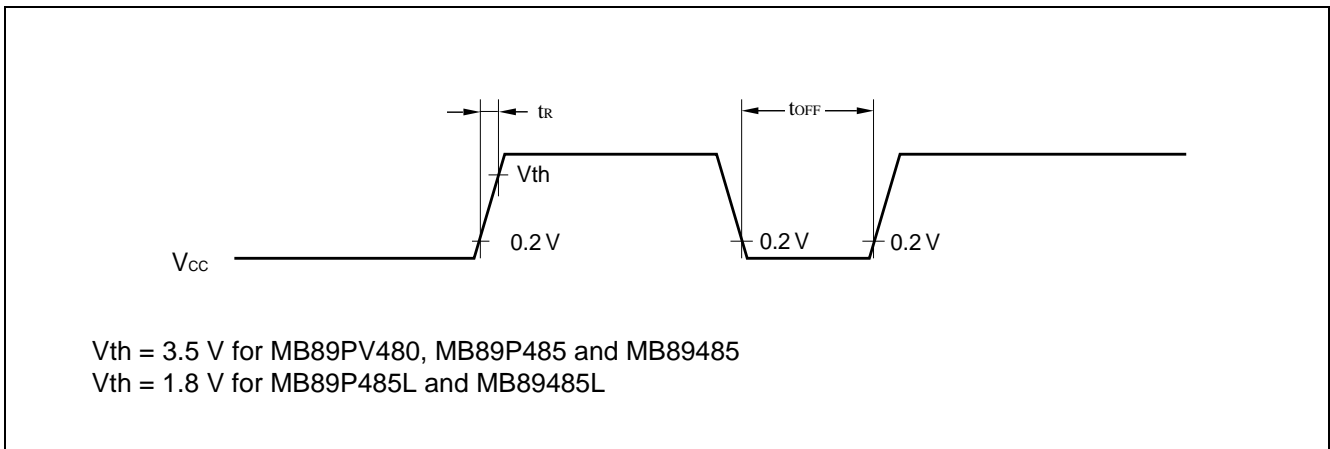

MB89480/480L Series

(3) Clock Timing

($V_{SS} = V_{SS} = 0.0\text{ V}$, $T_A = -40^\circ\text{C}$ to $+85^\circ\text{C}$)

Parameter	Symbol	Pin	Value			Unit	Remarks
			Min	Typ	Max		
Clock frequency	F_{CH}	X0, X1	1	—	12.5	MHz	
	F_{CL}	X0A, X1A	—	32.768	—	kHz	
Clock cycle time	t_{HCYL}	X0, X1	80	—	1000	ns	
	t_{LCYL}	X0A, X1A	—	30.5	—	μs	
Input clock pulse width	P_{WH} P_{WL}	X0	20	—	—	ns	External clock
	P_{WHL} P_{WLL}	X0A	—	15.2	—	μs	
Input clock rising/falling time	t_{CR} t_{CF}	X0, X0A	—	—	10	ns	

X0 and X1 Timing and Conditions

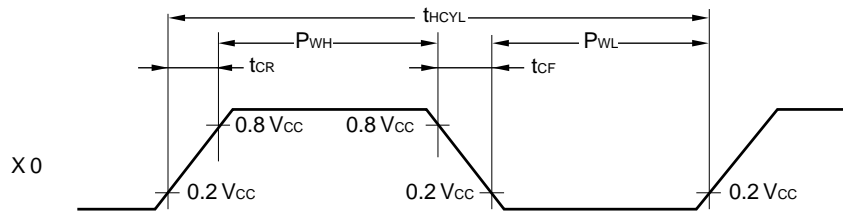

Main Clock Conditions

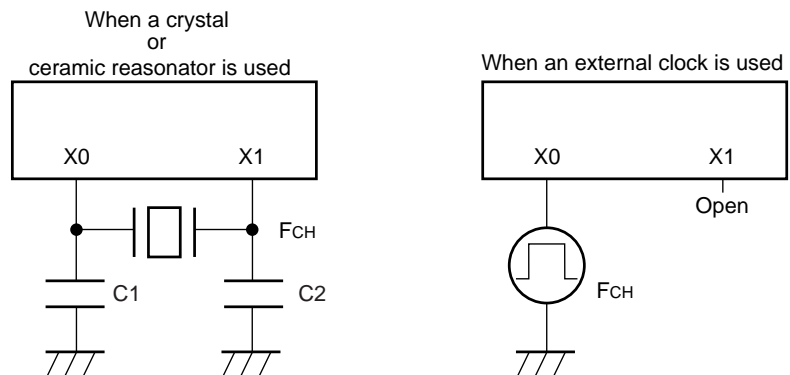

MB89480/480L Series

Sub-clock Timing and Conditions

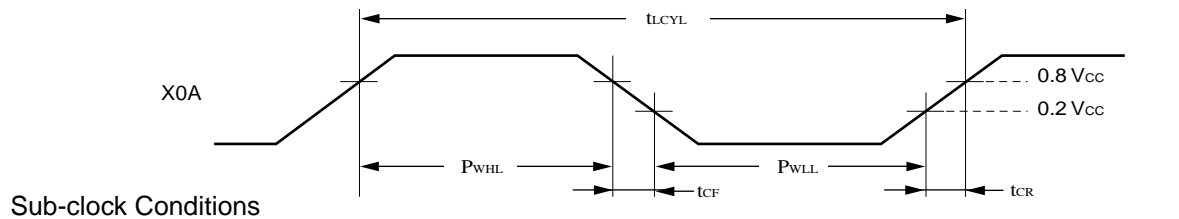

Sub-clock Conditions

When a crystal or ceramic oscillator is used

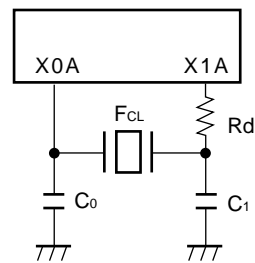

When an external clock is used

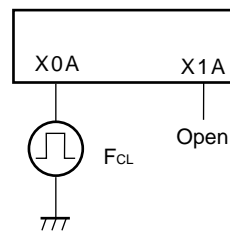

When subclock is not used

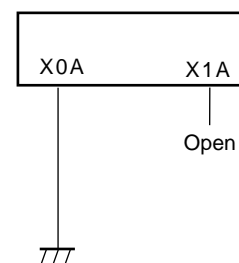

(4) Instruction Cycle

Parameter	Symbol	Value	Unit	Remarks
Instruction cycle (minimum execution time)	t _{inst}	4/F _{CH} , 8/F _{CH} , 16/F _{CH} , 64/F _{CH}	μs	(4/F _{CH})t _{inst} = 0.32 μs when operating at F _{CH} = 12.5 MHz
		2/F _{CL}	μs	t _{inst} = 61.036 μs when operating at F _{CL} = 32.768 kHz

MB89480/480L Series

(5) Serial I/O Timing

($AV_{CC} = V_{CC} = 5.0$ V for MB89PV480, MB89P485, MB89485,
 $AV_{CC} = V_{CC} = 3.0$ V for MB89P485L, MB89485L
 $AV_{SS} = V_{SS} = 0.0$ V, $T_A = -40^{\circ}\text{C}$ to $+85^{\circ}\text{C}$)

Parameter	Symbol	Pin	Condition	Value		Unit
				Min	Max	
Serial clock cycle time	t_{SCYC}	SCK	Internal shift clock mode	$2 t_{inst}^*$	—	μs
SCK $\downarrow \rightarrow$ SO time	t_{SLOV}	SCK, SO		-200	200	ns
Valid SI \rightarrow SCK \uparrow	t_{IVSH}	SI, SCK		$1/2 t_{inst}^*$	—	μs
SCK $\uparrow \rightarrow$ valid SI hold time	t_{SHIX}	SCK, SI		$1/2 t_{inst}^*$	—	μs
Serial clock "H" pulse width	t_{SHSL}	SCK	External shift clock mode	$1 t_{inst}^*$	—	μs
Serial clock "L" pulse width	t_{SLSH}			$1 t_{inst}^*$	—	μs
SCK $\downarrow \rightarrow$ SO time	t_{SLOV}	SCK, SO		0	200	ns
Valid SI \rightarrow SCK \uparrow	t_{IVSH}	SI, SCK		$1/2 t_{inst}^*$	—	μs
SCK $\uparrow \rightarrow$ valid SI hold time	t_{SHIX}	SCK, SI		$1/2 t_{inst}^*$	—	μs

* : For information on t_{inst} , see "(4) Instruction Cycle."

MB89480/480L Series

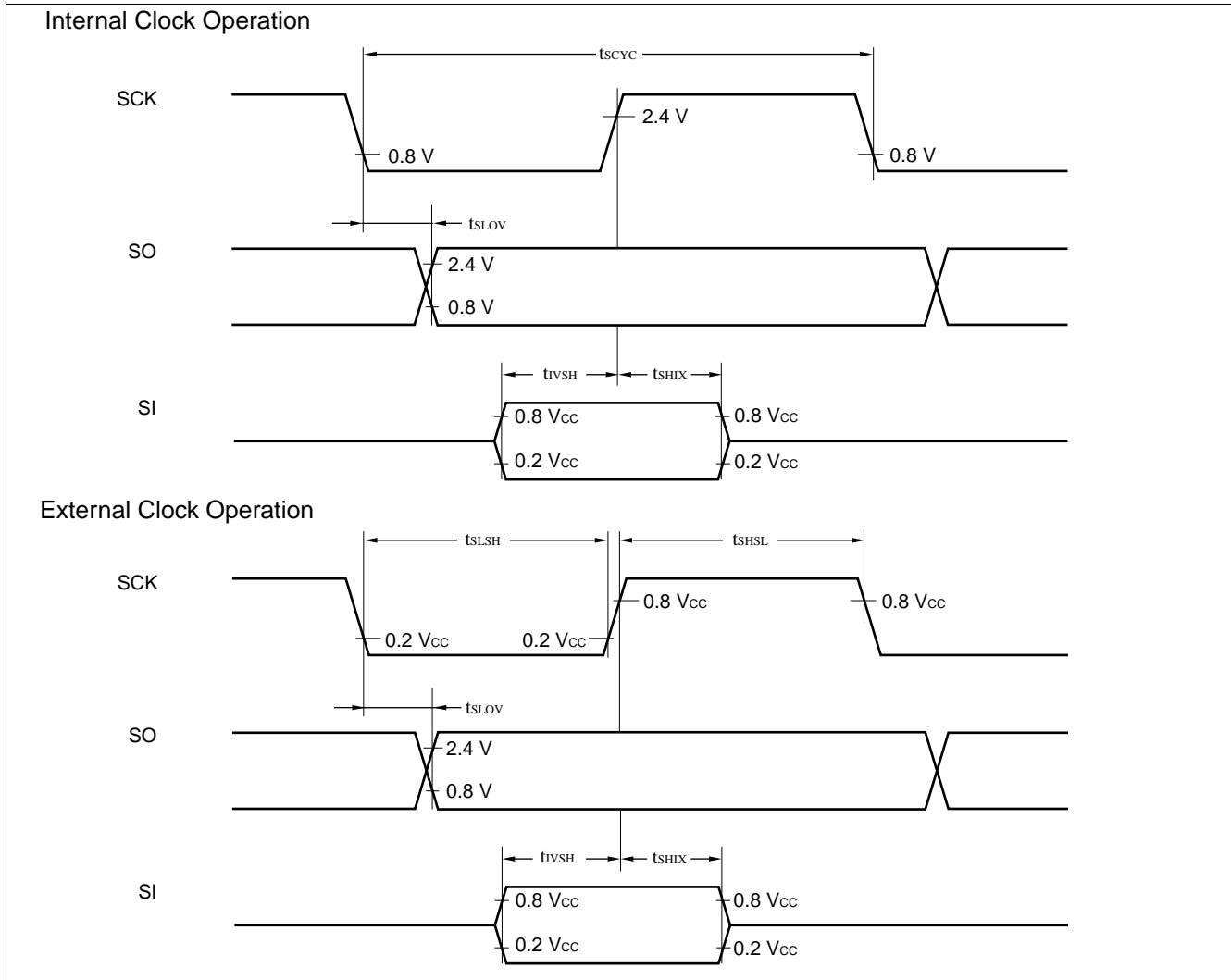

MB89480/480L Series

(6) Peripheral Input Timing

($A_{V_{CC}} = V_{CC} = 5.0\text{ V}$ for MB89PV480, MB89P485, MB89485
 $A_{V_{CC}} = V_{CC} = 3.0\text{ V}$ for MB89P485L, MB89485L
 $A_{V_{SS}} = V_{SS} = 0.0\text{ V}$, $T_A = -40^\circ\text{C}$ to $+85^\circ\text{C}$)

Parameter	Symbol	Pin	Value		Unit	Remarks
			Min	Max		
Peripheral input "H" pulse width 1	t_{ILIH1}	INT10 to INT13, INT20 to INT27, EC1, EC2, PWC	$2 t_{inst}^*$	—	μs	
Peripheral input "L" pulse width 1	t_{IHIL1}		$2 t_{inst}^*$	—	μs	

* : For information on t_{inst} , see "(4) Instruction Cycle."

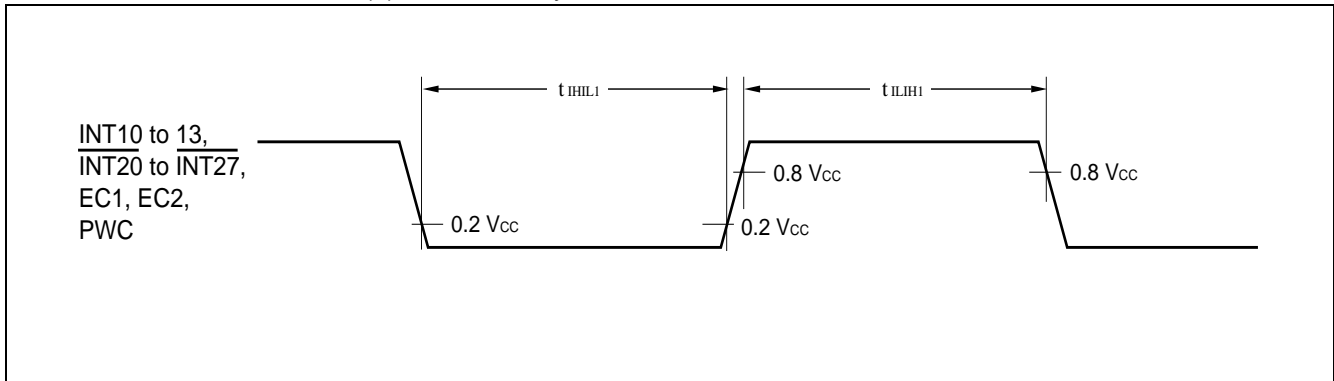

MB89480/480L Series

5. A/D Converter Electrical Characteristics

(1) A/D Converter Electrical Characteristics

($AV_{CC} = V_{CC} = 4.5\text{ V to }5.5\text{ V}$ for MB89PV480, MB89P485, MB89485,
 $AV_{CC} = V_{CC} = 2.7\text{ V to }3.6\text{ V}$ for MB89P485L, MB89485L,
 $AV_{SS} = V_{SS} = 0.0\text{ V}$, $T_A = -40^\circ\text{C to }+85^\circ\text{C}$)

Parameter	Symbol	Pin	Value			Unit	Remarks
			Min	Typ	Max		
Resolution	—	—	—	10	—	bit	
Total error			—	—	± 4.0	LSB	
Linearity error			—	—	± 2.5	LSB	
Differential linearity error			—	—	± 1.9	LSB	
Zero transition voltage	V_{OT}	—	$AV_{SS} - 1.5$ LSB	$AV_{SS} + 0.5$ LSB	$AV_{SS} + 2.5$ LSB	mV	
Full-scale transition voltage	V_{FST}		$AV_{CC} - 4.5$ LSB	$AV_{CC} - 2.5$ LSB	$AV_{CC} - 0.5$ LSB	mV	
A/D mode conversion time	—		—	—	$60 t_{inst}^*$	μs	
Analog port input current	I_{AIN}	AN0 to AN3	—	—	10	μA	
Analog input voltage	V_{AIN}	AN0 to AN3	AV_{SS}	—	AV_{CC}	V	

* : For information on t_{inst} , see "(4) Instruction Cycle" in "4. AC Characteristics".

(2) A/D Converter Glossary

- Resolution
Analog changes that are identifiable with the A/D converter.
When the number of bits is 10, analog voltage can be divided into $2^{10} = 1024$.
- Linearity error (unit: LSB)
The deviation of the straight line connecting the zero transition point ("00 0000 0000" \leftrightarrow "00 0000 0001") with the full-scale transition point ("11 1111 1111" \leftrightarrow "11 1111 1110") from actual conversion characteristics.
- Differential linearity error (unit: LSB)
The deviation of input voltage needed to change the output code by 1 LSB from the theoretical value.
- Total error (unit: LSB)
The difference between theoretical and actual conversion values.

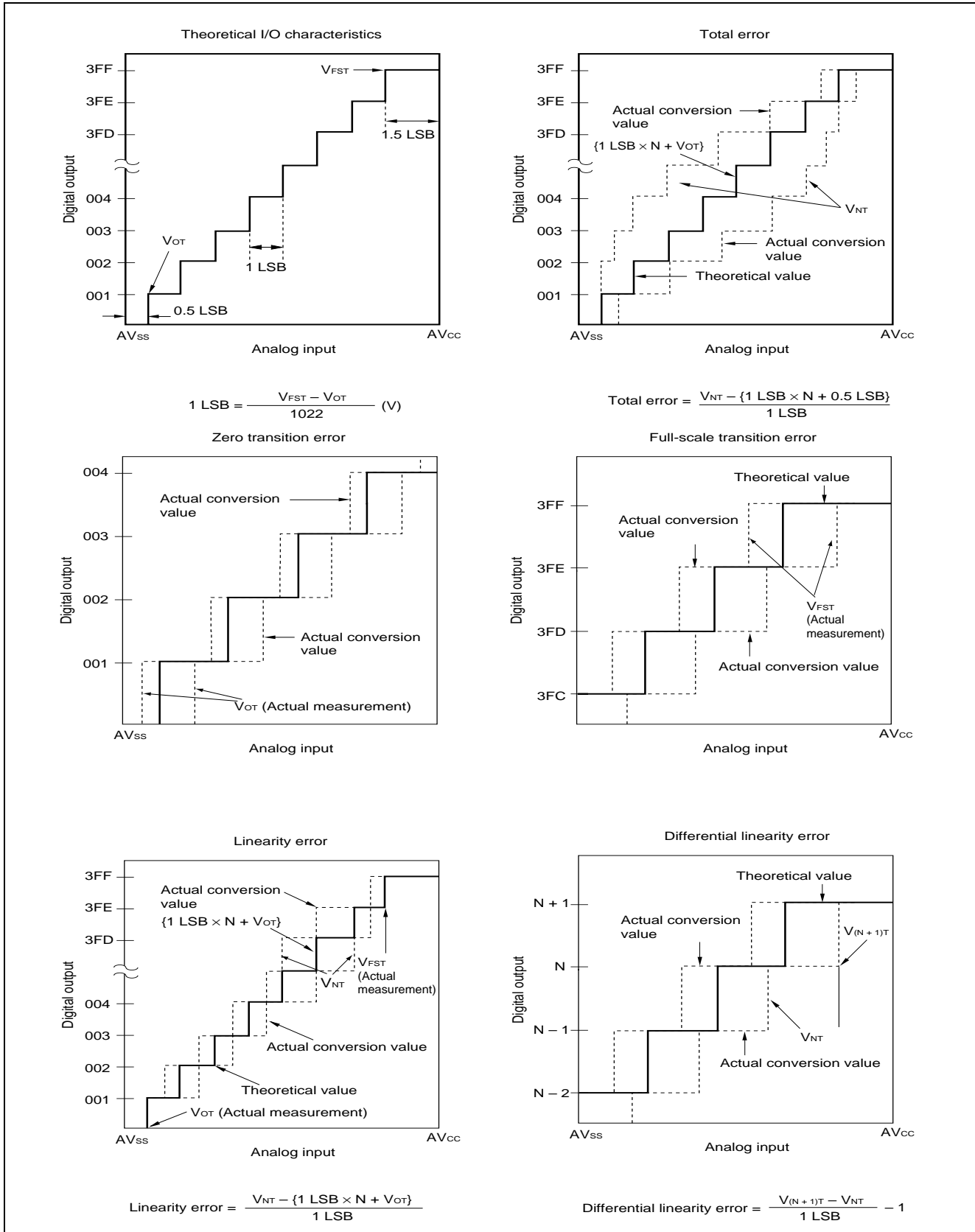

MB89480/480L Series

(3) Notes on Using A/D Converter

- Input impedance of the analog input pins

The A/D converter used for the MB89480 series contains a sample and hold circuit as illustrated below to fetch analog input voltage into the sample and hold capacitor for 16 instruction cycles after activation A/D conversion.

For this reason, if the output impedance of the external circuit for the analog input is high, analog input voltage might not stabilize within the analog input sampling period. Therefore, it is recommended to keep the output impedance of the external circuit low.

Note that if the impedance cannot be kept low, it is recommended to connect an external capacitor of about 0.1 μF for the analog input pin.

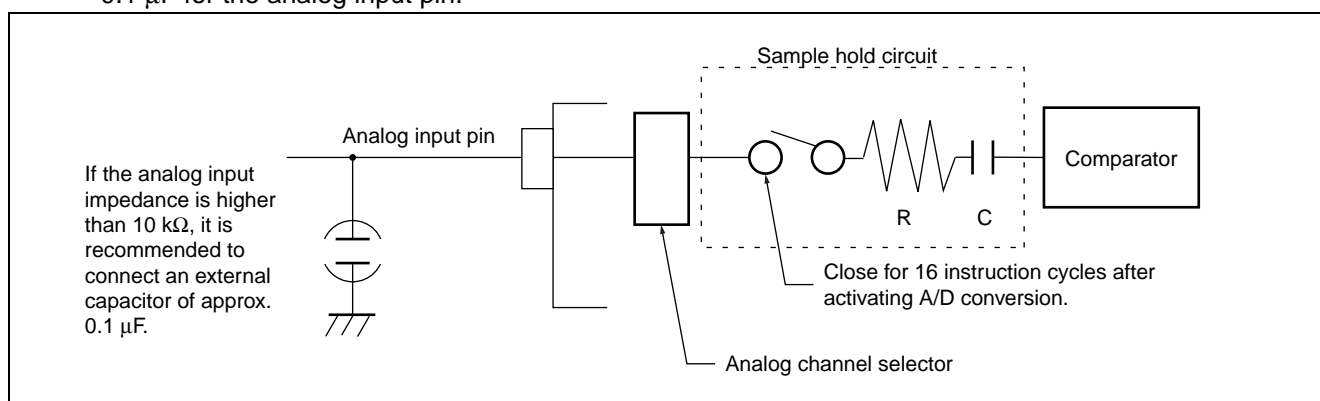

	MB89485 MB89PV480	MB89485L	MB89P485	MB89P485L
R: analog input equivalent resistance	2.2 k Ω	2.8 k Ω	2.6 k Ω	7.1 k Ω
C: analog input equivalent capacitance	45 pF	46 pF	28 pF	48.3 pF

MB89480/480L Series

EXAMPLE CHARACTERISTICS

(1) "L" level output voltage

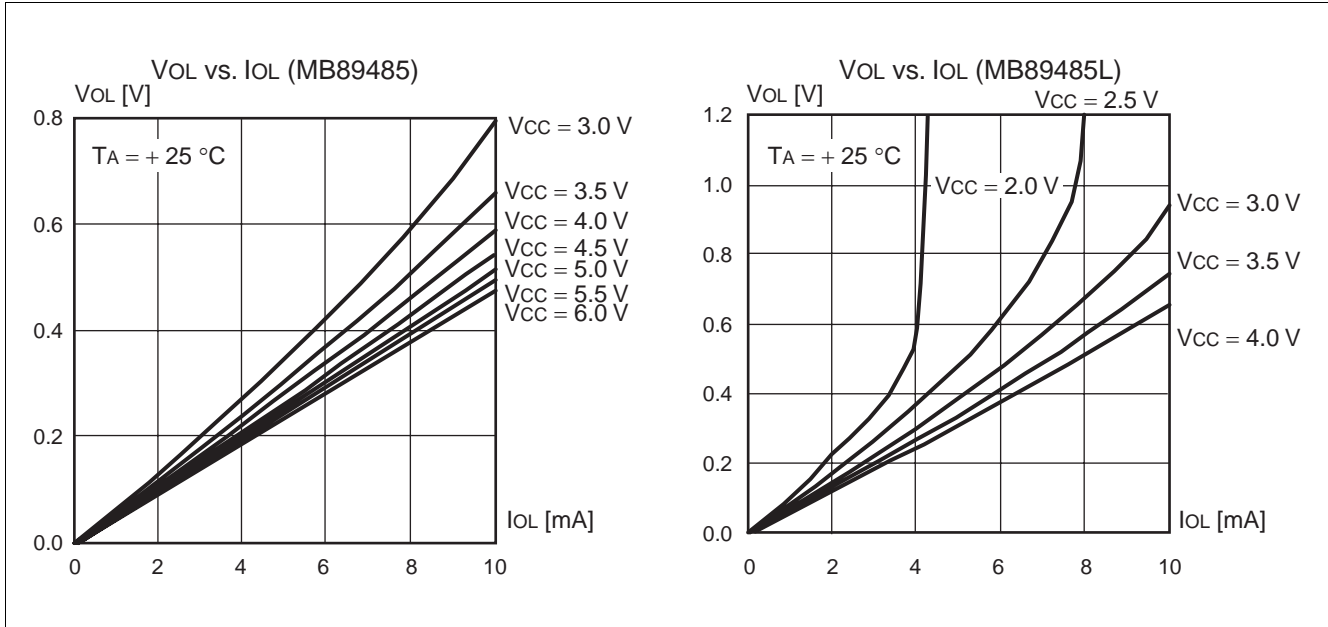

(2) "H" level output voltage

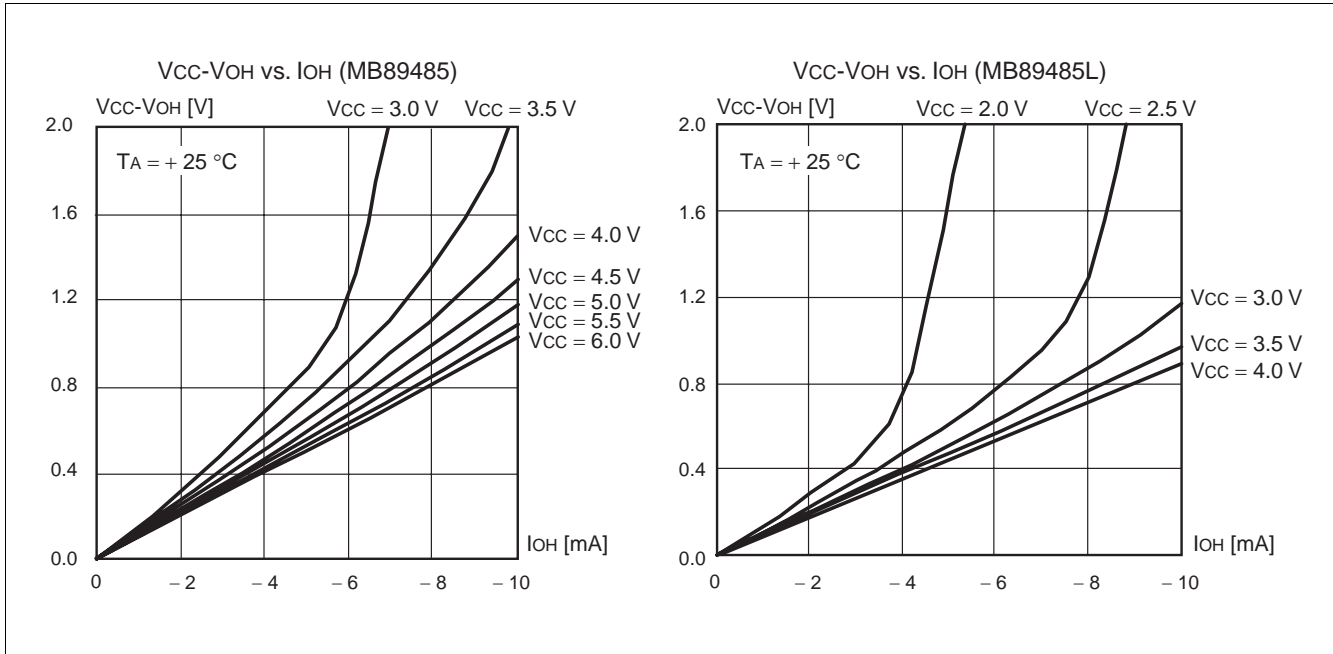

MB89480/480L Series

(3) "H" level input voltage/"L" level input voltage

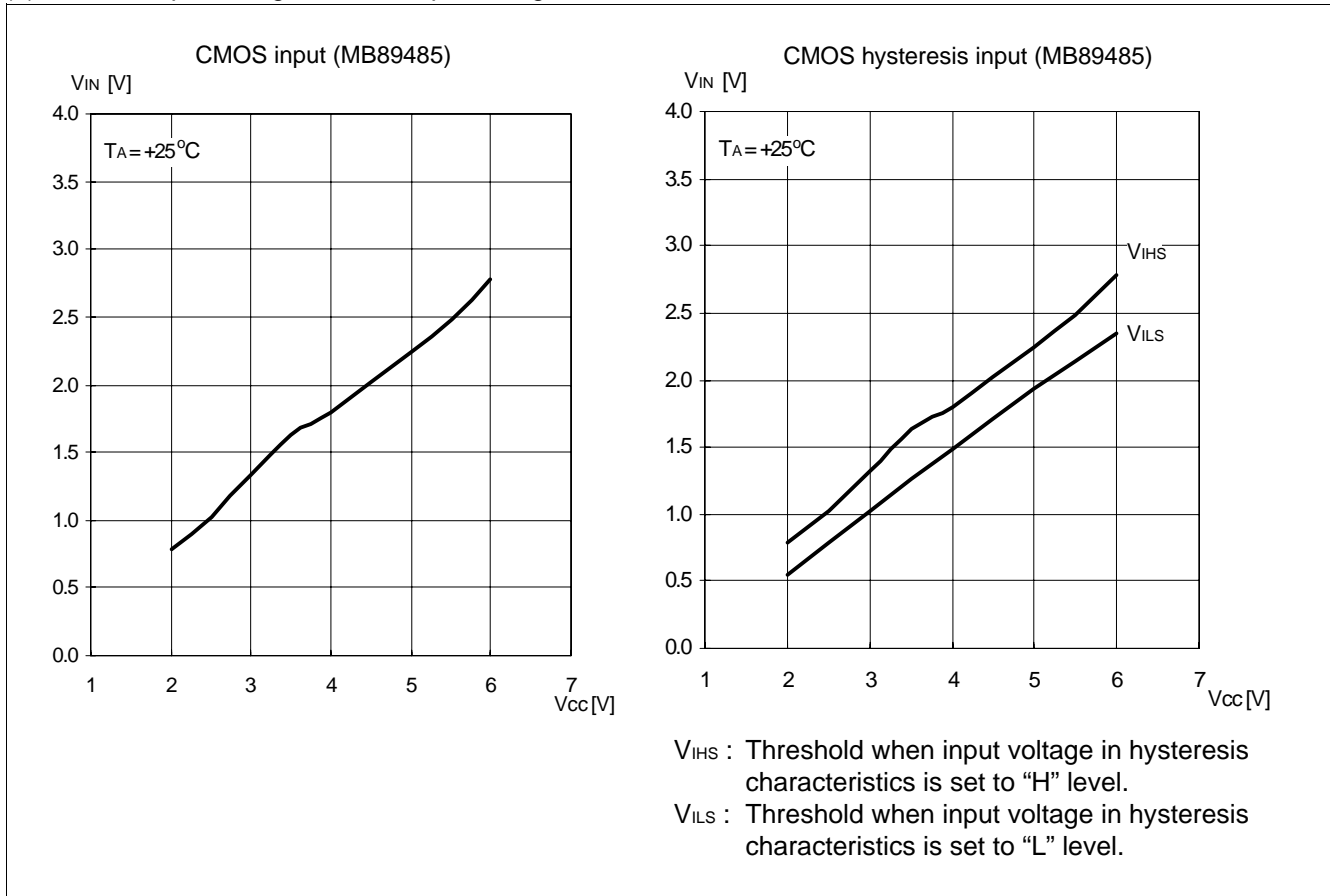

MB89480/480L Series

(4) Power supply current (External clock)

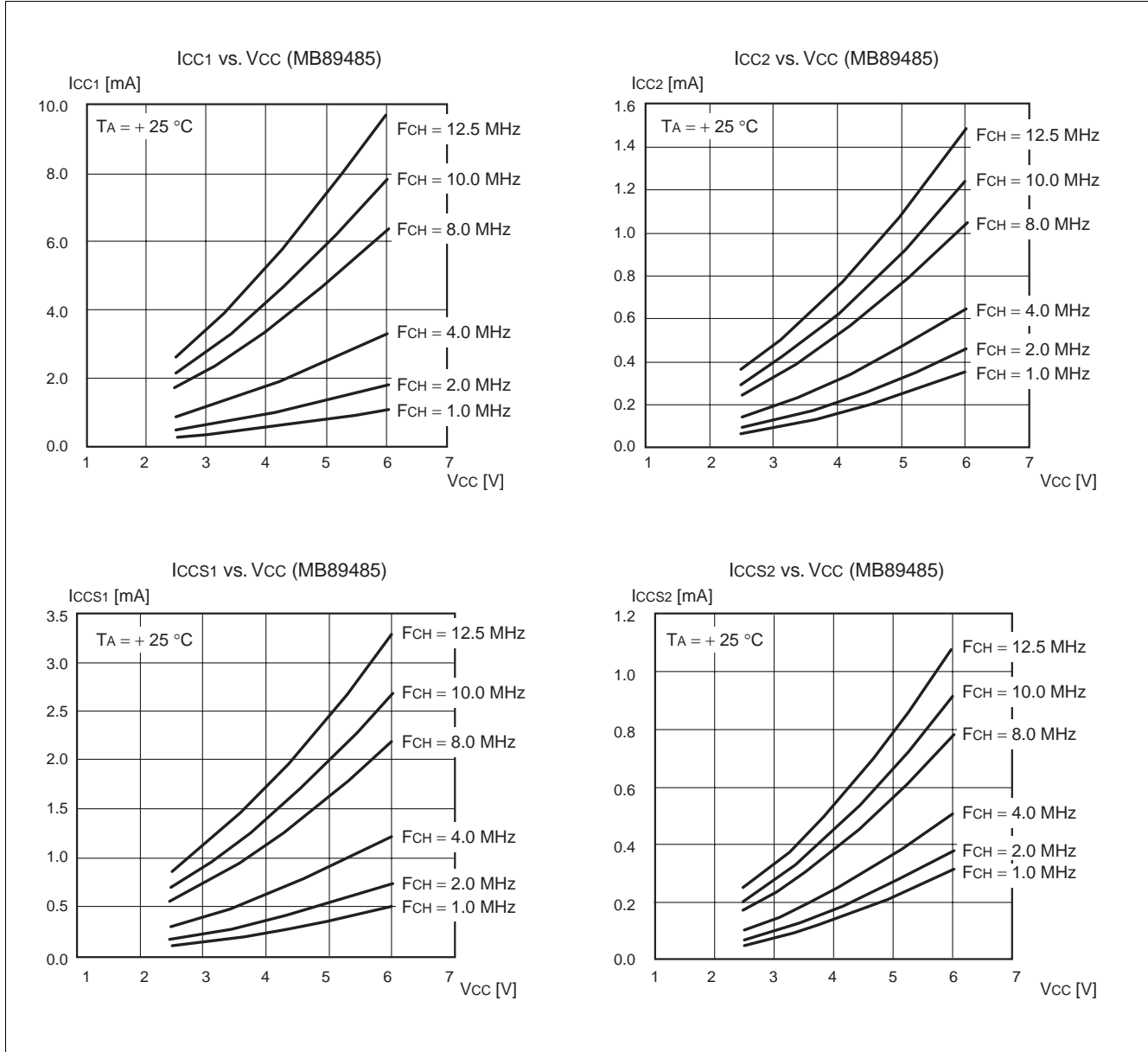

(Continued)

MB89480/480L Series

(Continued)

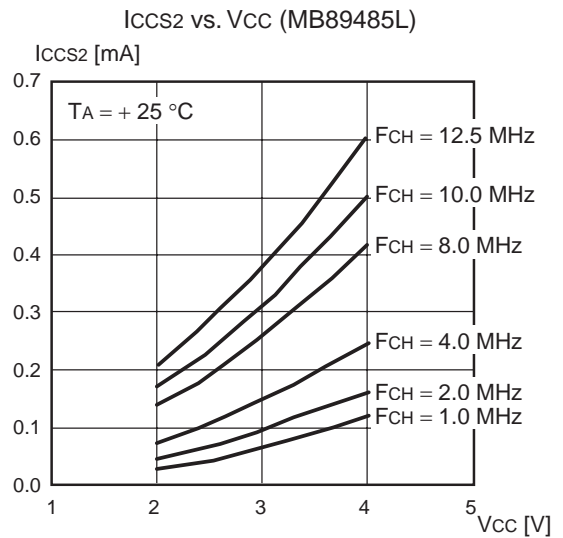
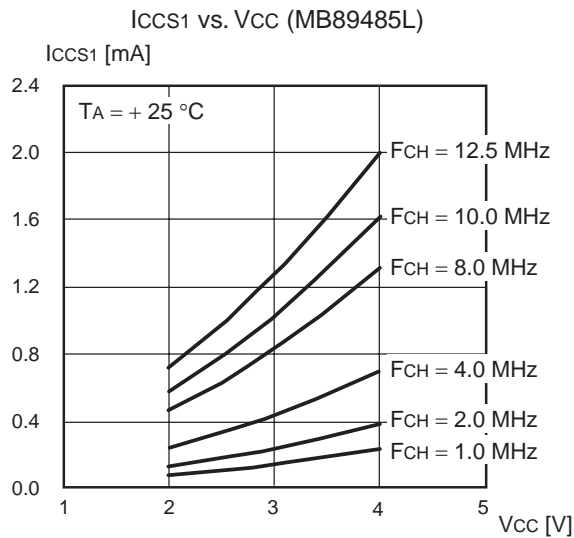
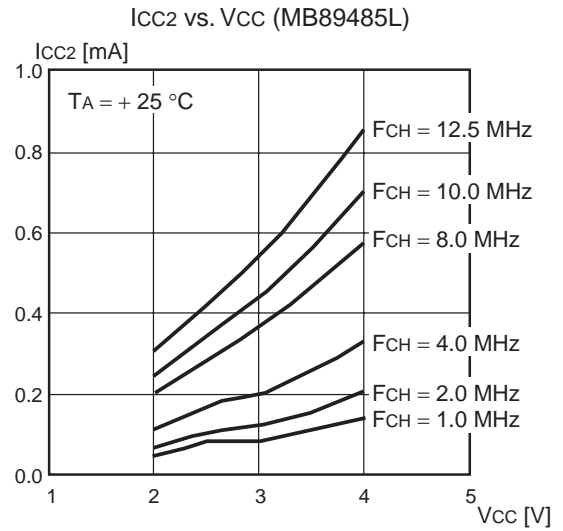
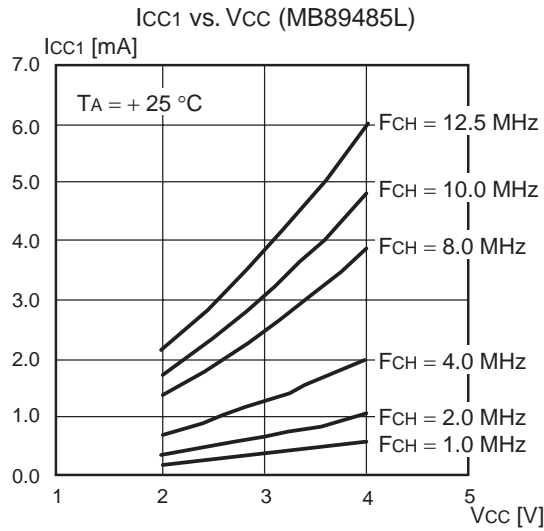

MB89480/480L Series

(Continued)

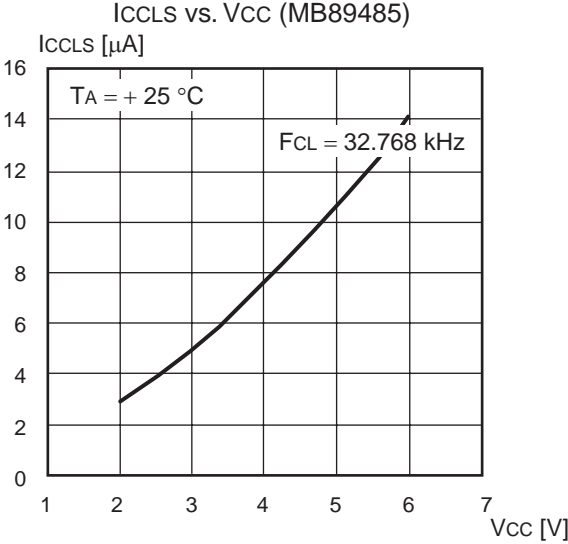
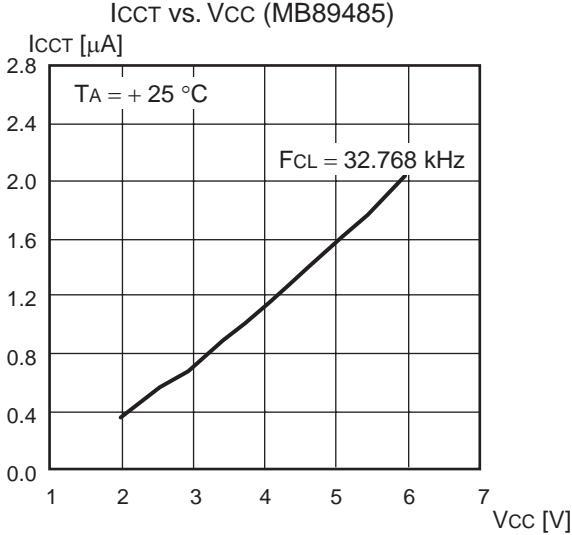
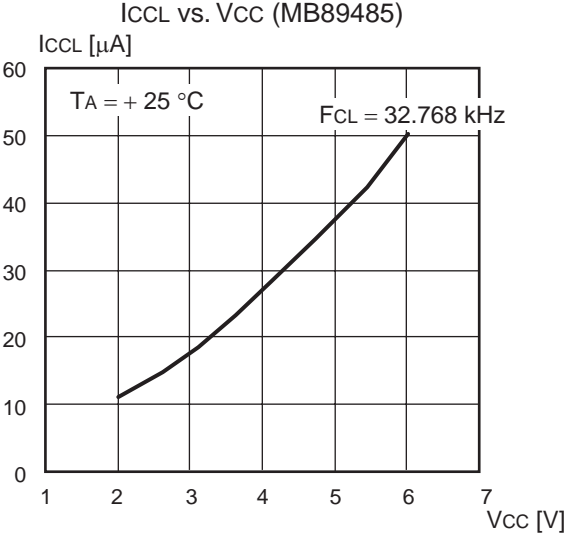

MB89480/480L Series

(5) Pull-up resistance

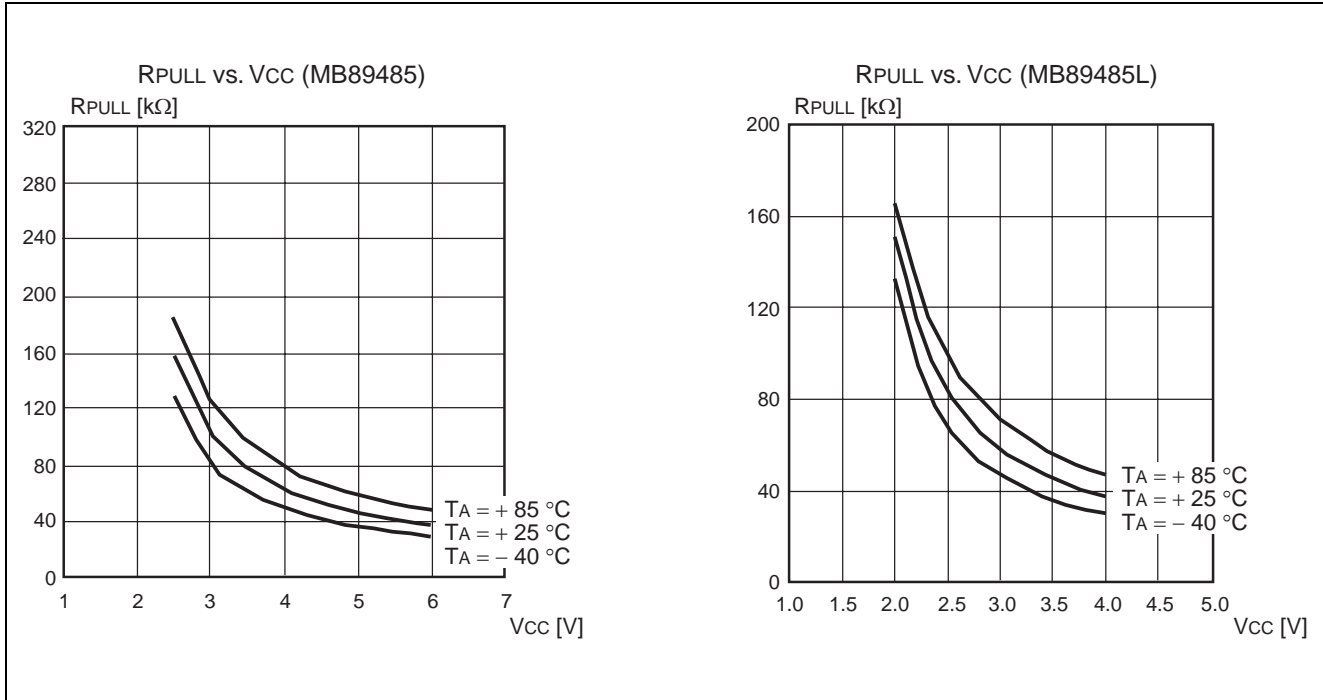

MB89480/480L Series

■ MASK OPTIONS

No.	Part number	MB89485	MB89485L	MB89P485	MB89P485L	MB89PV480
	Specifying procedure	Specify when ordering mask		Setting not possible		Setting not possible
1	Booster selection (KSV) • Internal resistor ladder • Booster	Selectable		101/103 : Internal resistor ladder 102/104: Booster		101 : Internal resistor ladder 102: Booster
2	Selection of OTPROM content protection feature • No protection feature • With protection feature	—		101/102 : No protection 103/104 : With protection		—
3	Selection of oscillation stabilization time (OSC) $2^{14}/F_{CH}$ (approx.1.3 ms) $2^{17}/F_{CH}$ (approx.10.5 ms) $2^{18}/F_{CH}$ (approx.21.0 ms)	Selectable OSC		$2^{18}/F_{CH}$ (approx.21.0 ms)		$2^{18}/F_{CH}$ (approx.21.0 ms)
4	Selection of power-on stabilization time • Nil • $2^{17}/F_{CH}$	Selectable	Fixed to nil	$2^{17}/F_{CH}$	Fixed to nil	Fixed to nil

MB89480/480L Series

■ ORDERING INFORMATION

Part number	Package	Remarks
MB89485PFM MB89P485-101PFM MB89P485-102PFM MB89P485-103PFM MB89P485-104PFM MB89485LPFM MB89P485L-101PFM MB89P485L-102PFM MB89P485L-103PFM MB89P485L-104PFM	64-pin Plastic QFP (FPT-64P-M09)	101: With internal resistor ladder, without content protection 102: With booster, without content protection 103: With internal resistor ladder, with content protection 104: With booster, with content protection
MB89485P-SH MB89P485-101P-SH MB89P485-102P-SH MB89P485-103P-SH MB89P485-104P-SH MB89485LP-SH MB89P485L-101P-SH MB89P485L-102P-SH MB89P485L-103P-SH MB89P485L-104P-SH	64-pin Plastic SH-DIP (DIP-64P-M01)	
MB89PV480-101C-SH MB89PV480-102C-SH	64-pin Ceramic MDIP (MDP-64C-P02)	
MB89PV480-101CF MB89PV480-102CF	64-pin Ceramic MQFP (MQP-64C-P01)	

MB89480/480L Series

■ PACKAGE DIMENSIONS

64-pin Plastic SH-DIP
(DIP-64P-M01)

Note: Pins width and pins thickness include plating thickness.

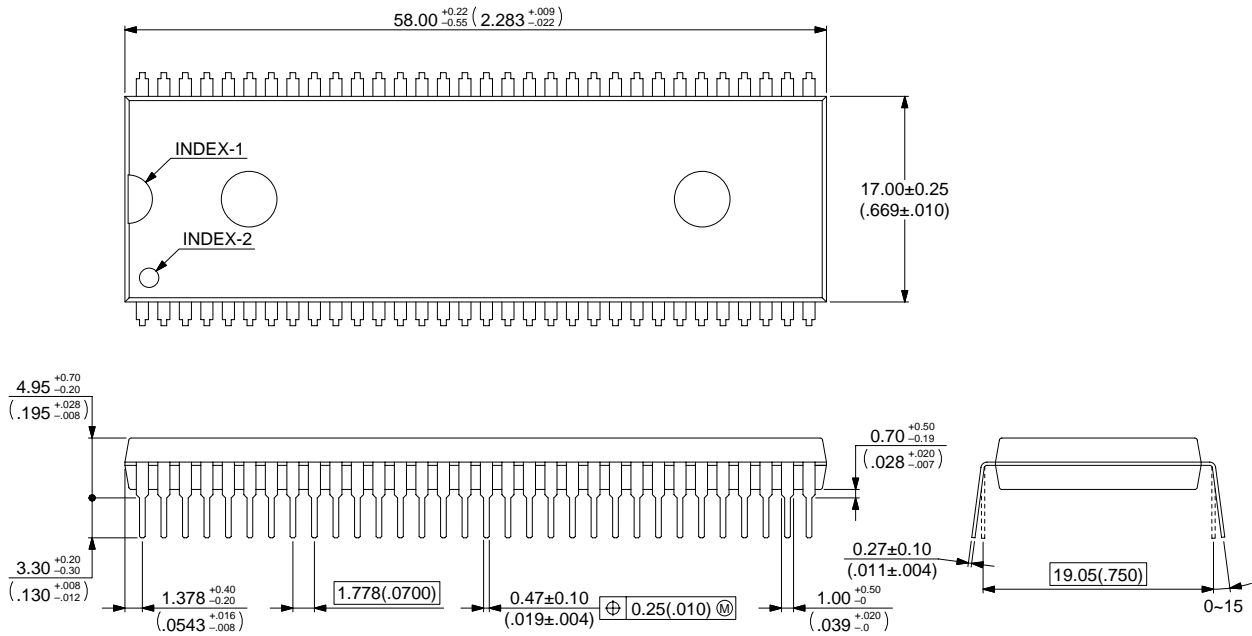

© 2001 FUJITSU LIMITED D64001S-c-4-5

Dimensions in mm (inches)

Note : The values in parenthese are reference values.

(Continued)

MB89480/480L Series

64-pin Plastic LQFP
(FPT-64P-M09)

Note 1) * : These dimensions do not include resin protrusion.
 Note 2) Pins width and pins thickness include plating thickness.
 Note 3) Pins width do not include tie bar remainder.

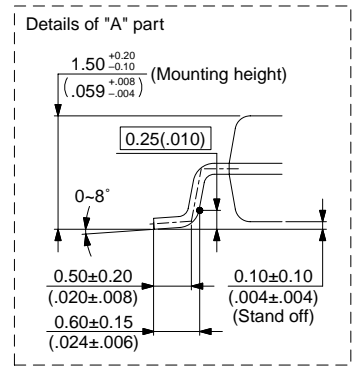
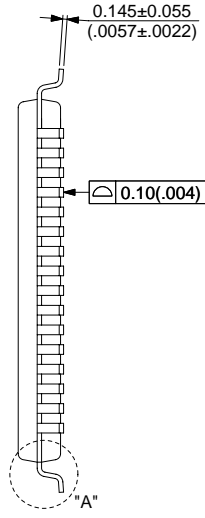
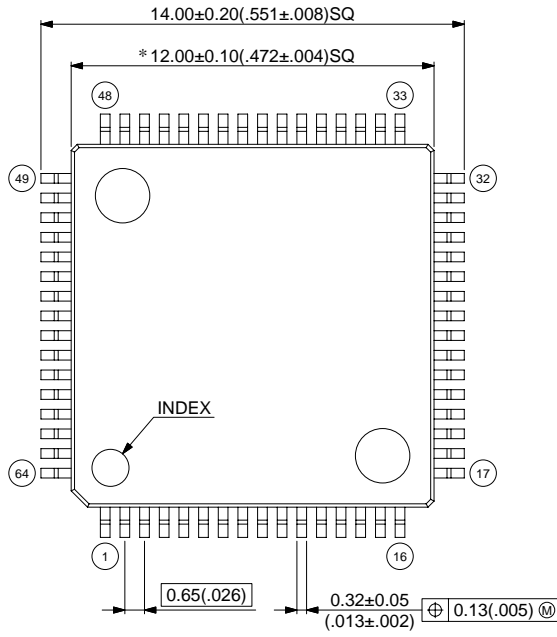

© 2003 FUJITSU LIMITED F64018S-c-3-5

Dimensions in mm (inches)

Note : The values in parentheses are reference values.

(Continued)

MB89480/480L Series

64-pin Ceramic MDIP
(MDP-64C-P02)

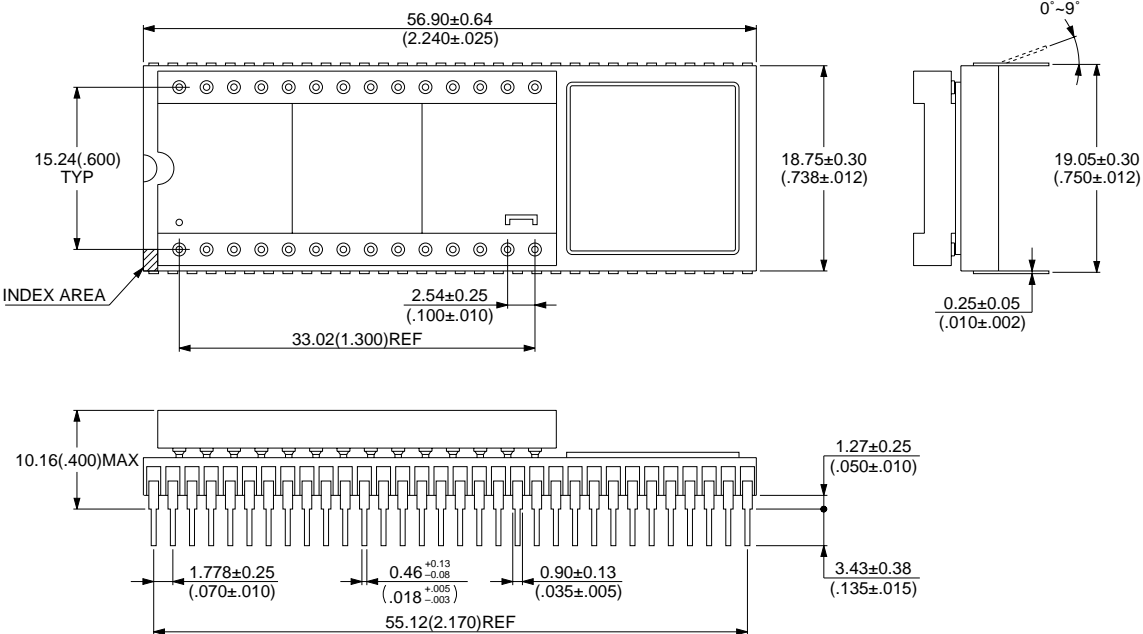

© 1994 FUJITSU LIMITED M64002SC-1-4

Dimensions in mm (inches)
Note : The values in parentheses are reference values.

(Continued)

MB89480/480L Series

(Continued)

64-pin Ceramic MQFP
(MQP-64C-P01)

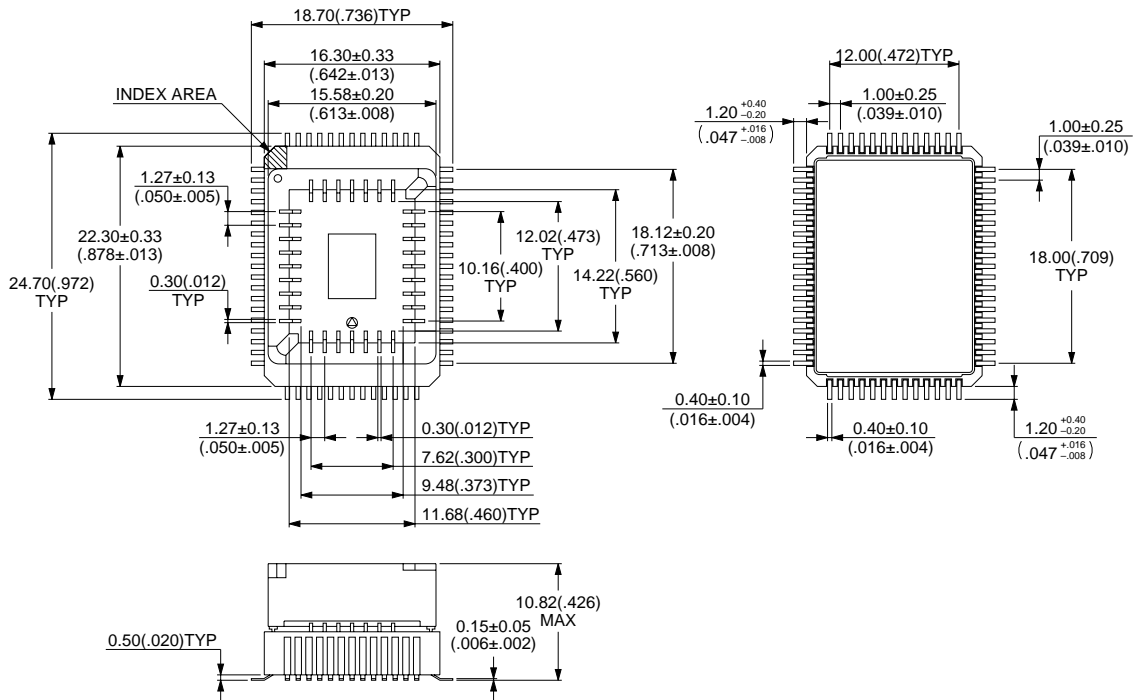

© 1994 FUJITSU LIMITED M64004SC-1-3

Dimensions in mm (inches)

Note : The values in parentheses are referent value.

MEMO

FUJITSU MICROELECTRONICS LIMITED

Shinjuku Dai-Ichi Seimei Bldg. 7-1, Nishishinjuku 2-chome, Shinjuku-ku,
Tokyo 163-0722, Japan Tel: +81-3-5322-3347 Fax: +81-3-5322-3387
<http://jp.fujitsu.com/fml/en/>

For further information please contact:

North and South America

FUJITSU MICROELECTRONICS AMERICA, INC.
1250 E. Arques Avenue, M/S 333
Sunnyvale, CA 94085-5401, U.S.A.
Tel: +1-408-737-5600 Fax: +1-408-737-5999
<http://www.fma.fujitsu.com/>

Europe

FUJITSU MICROELECTRONICS EUROPE GmbH
Pittlerstrasse 47, 63225 Langen,
Germany
Tel: +49-6103-690-0 Fax: +49-6103-690-122
<http://emea.fujitsu.com/microelectronics/>

Korea

FUJITSU MICROELECTRONICS KOREA LTD.
206 KOSMO TOWER, 1002 Daechi-Dong,
Kangnam-Gu, Seoul 135-280
Korea
Tel: +82-2-3484-7100 Fax: +82-2-3484-7111
<http://www.fmk.fujitsu.com/>

Asia Pacific

FUJITSU MICROELECTRONICS ASIA PTE LTD.
151 Lorong Chuan, #05-08 New Tech Park,
Singapore 556741
Tel: +65-6281-0770 Fax: +65-6281-0220
<http://www.fujitsu.com/sg/services/micro/semiconductor/>

FUJITSU MICROELECTRONICS SHANGHAI CO., LTD.
Rm.3102, Bund Center, No.222 Yan An Road(E),
Shanghai 200002, China
Tel: +86-21-6335-1560 Fax: +86-21-6335-1605
<http://cn.fujitsu.com/fmc/>

FUJITSU MICROELECTRONICS PACIFIC ASIA LTD.
10/F., World Commerce Centre, 11 Canton Road
Tsimshatsui, Kowloon
Hong Kong
Tel: +852-2377-0226 Fax: +852-2376-3269
<http://cn.fujitsu.com/fmc/tw>

All Rights Reserved.

The contents of this document are subject to change without notice.

Customers are advised to consult with sales representatives before ordering.

The information, such as descriptions of function and application circuit examples, in this document are presented solely for the purpose of reference to show examples of operations and uses of FUJITSU MICROELECTRONICS device; FUJITSU MICROELECTRONICS does not warrant proper operation of the device with respect to use based on such information. When you develop equipment incorporating the device based on such information, you must assume any responsibility arising out of such use of the information.

FUJITSU MICROELECTRONICS assumes no liability for any damages whatsoever arising out of the use of the information.

Any information in this document, including descriptions of function and schematic diagrams, shall not be construed as license of the use or exercise of any intellectual property right, such as patent right or copyright, or any other right of FUJITSU MICROELECTRONICS or any third party or does FUJITSU MICROELECTRONICS warrant non-infringement of any third-party's intellectual property right or other right by using such information. FUJITSU MICROELECTRONICS assumes no liability for any infringement of the intellectual property rights or other rights of third parties which would result from the use of information contained herein.

The products described in this document are designed, developed and manufactured as contemplated for general use, including without limitation, ordinary industrial use, general office use, personal use, and household use, but are not designed, developed and manufactured as contemplated (1) for use accompanying fatal risks or dangers that, unless extremely high safety is secured, could have a serious effect to the public, and could lead directly to death, personal injury, severe physical damage or other loss (i.e., nuclear reaction control in nuclear facility, aircraft flight control, air traffic control, mass transport control, medical life support system, missile launch control in weapon system), or (2) for use requiring extremely high reliability (i.e., submersible repeater and artificial satellite).

Please note that FUJITSU MICROELECTRONICS will not be liable against you and/or any third party for any claims or damages arising in connection with above-mentioned uses of the products.

Any semiconductor devices have an inherent chance of failure. You must protect against injury, damage or loss from such failures by incorporating safety design measures into your facility and equipment such as redundancy, fire protection, and prevention of over-current levels and other abnormal operating conditions.

Exportation/release of any products described in this document may require necessary procedures in accordance with the regulations of the Foreign Exchange and Foreign Trade Control Law of Japan and/or US export control laws.

The company names and brand names herein are the trademarks or registered trademarks of their respective owners.