

FEATURES

- up to 80 dB of electrical gain
- dedicated preamp for a telecoil
- direct coupling of a telecoil to preamp
- low input referred noise
- on chip voltage regulator
- capable of driving low impedance receivers

STANDARD PACKAGING

- Hybrid typical dimensions
0.250 in x 0.150 in x 0.115 in
(6.35 mm x 3.81 mm x 2.92 mm)

DESCRIPTION

The GM3008 hybrid consists of two of Gennum's proprietary integrated circuits, the GP537 preamplifier and the GS551 class B output driver. Such a configuration provides up to 80 dB (typ) of electrical gain. Low total harmonic distortion and input noise make this circuit well suited for high power applications. Various additional pads have been provided to allow for maximum flexibility of system performance.

The GP537 contains two low noise inverting preamplifiers with an open loop voltage gain of typically 50 dB, a telecoil preamplifier with its own reference voltage which enables for direct coupling of the telecoil and a voltage regulator with typically 74 dB of supply rejection capable of working with a supply voltage down to 1.1 volts. This chip also enables the user to disconnect the telecoil preamplifier when it is not required, thereby saving approximately 85 μ A of current.

The GS551 class B amplifier contains three basic blocks, a low noise inverting preamplifier, a unity gain phase splitter and a fixed gain class B output stage.

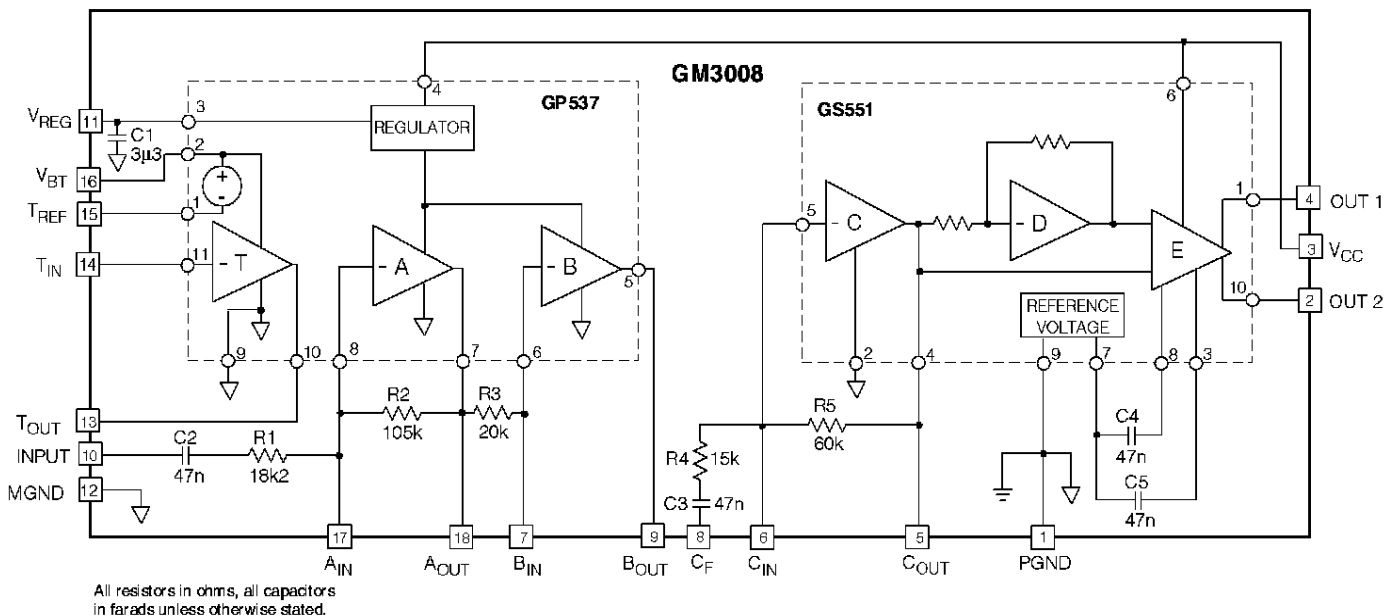

FUNCTIONAL BLOCK DIAGRAM

ABSOLUTE MAXIMUM RATINGS

PARAMETER	VALUE / UNITS
Supply Voltage	3 VDC
Power Dissipation	25 mW
Operating Temperature Range	-10° C to 40° C
Storage Temperature Range	-20° C to 70° C

PAD CONNECTION

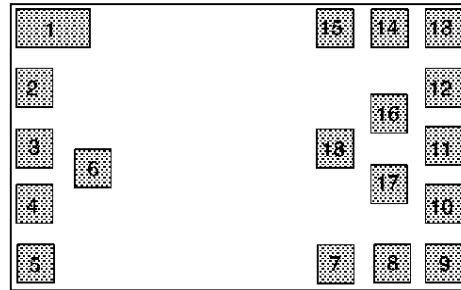

ELECTRICAL CHARACTERISTICS

Conditions: Frequency = 1 kHz, Temperature = 25°C, Supply Voltage $V_{CC} = 1.3$ V **Notes:** 1. All capacitors on hybrid $\pm 20\%$, all printed on resistors $\pm 5\%$

PARAMETER	SYMBOL	CONDITIONS	MIN	TYP	MAX	UNITS
Amplifier Current	I_{AMP}	S1 = Open	190	365	550	μ A
Telecoil Current	I_{TCOIL}		40	85	130	μ A
Transducer Current	I_{TRANS}	Quiescent Current $V_{IN} = 0$ V	100	250	390	μ A
REGULATOR						
Regulator Voltage	V_{REG}		0.88	0.93	0.98	V
Regulator Supply Rejection	PSRR		60	74	-	dB
T COIL						
Bias Voltage	V_{BIAS}	Pads 13, 14	540	580	620	mV
Telecoil Offset Voltage	V_{TOFF}	$V_{P15} - V_{P14}$	-10	0	10	mV
Input Bias Current	I_{BIAS}		-25	0	25	nA
Output Voltage Swing - Low	V_{OL}		200	280	-	mV
Maximum Sourcing Current	I_{SOURCE}		15	30	-	μ A
Open Loop Voltage Gain	A_{VOL}		46	50	-	dB
STAGES A & B						
Bias Voltage	V_{BIAS}	Pads 7, 9, 17, 18	540	580	620	mV
Input Bias Current	I_{BIAS}		-25	0	25	nA
Output Voltage Swing - Low	V_{OL}		200	280	-	mV
Maximum Sourcing Current	I_{SOURCE}		15	30	-	μ A
Open Loop Voltage Gain	A_{VOL}		46	50	-	dB
STAGE C						
Bias Voltage	V_{BIAS}	Pads 5, 6	540	580	620	mV
Input Bias Current	I_{BIAS}		-	0	-	nA
Output Voltage Swing - Low	V_{OL}		-	280	-	mV
Maximum Sourcing Current	I_{SOURCE}		-	50	-	μ A
Open Loop Voltage Gain	A_{VOL}		-	50	-	dB
STAGE D						
Voltage Gain	GAIN		-	0	-	dB
STAGE E						
AC Voltage Gain	GAIN		-	28	-	dB
Maximum Sourcing Current	I_{SOURCE}		-	>35	-	mA
SYSTEM PERFORMANCE						
System Voltage Gain	S_{GAIN}	$V_{IN} = -60$ dBV, $R_F = 39$ k	56	60	64	dB
Telecoil Gain	T_{GAIN}	S2 = b; $V_{IN} = -60$ dBV	16	18.5	20	dB
Total Harmonic Distortion	THD	$V_{IN} = -60$ dB, $R_F = 39$ k	-	3	5	%
Input Referred Noise	IRN		-	2.5	-	μ V

All parameters and switches remain as shown in the Test Circuit unless otherwise stated in CONDITIONS column.

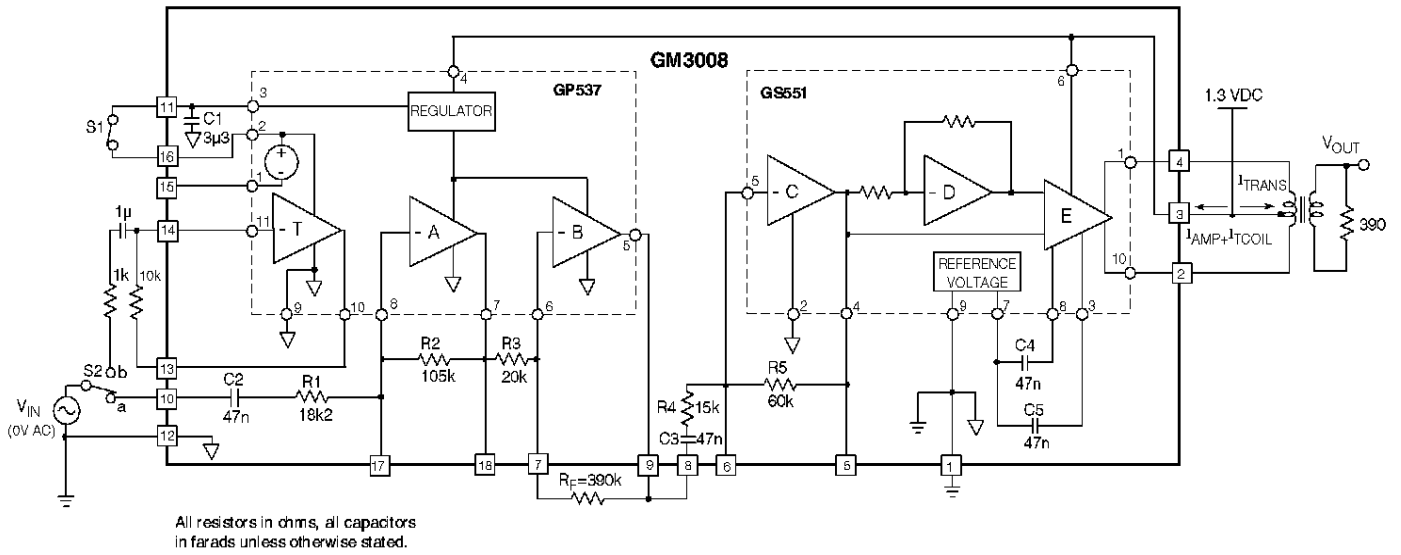

Fig. 1 Production Test Circuit

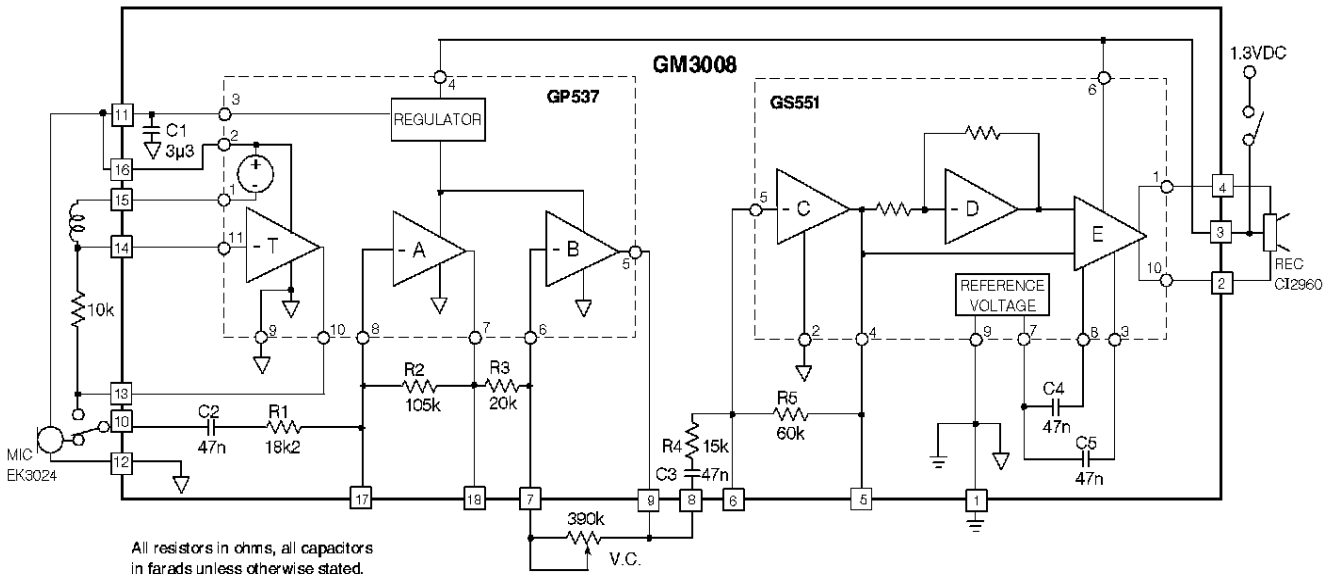

Fig. 2 Typical Hearing Instrument Application

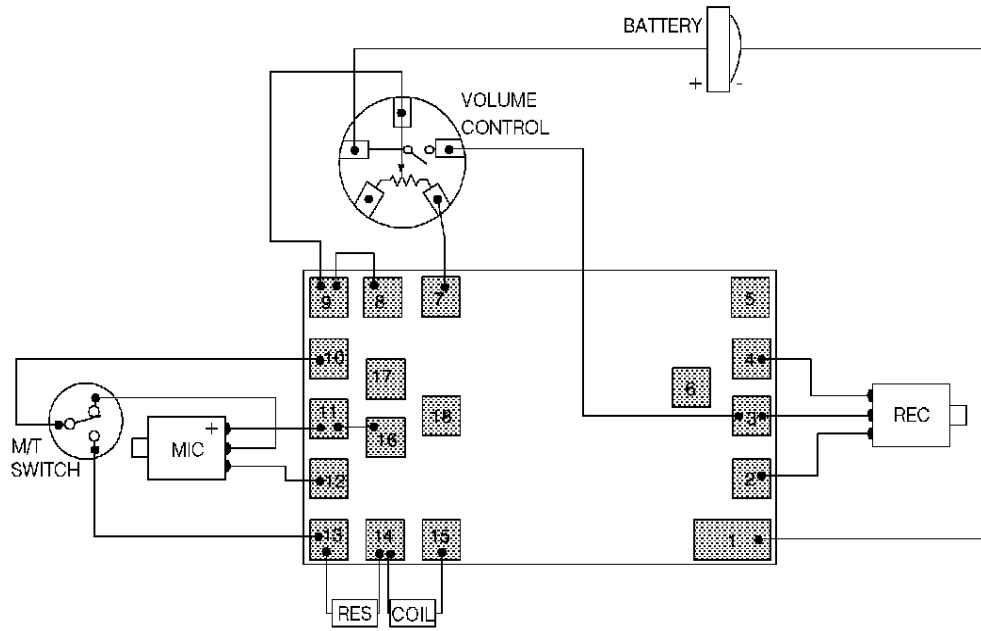

Fig. 3 Maximum Components Configuration Assembly Diagram of GM3008

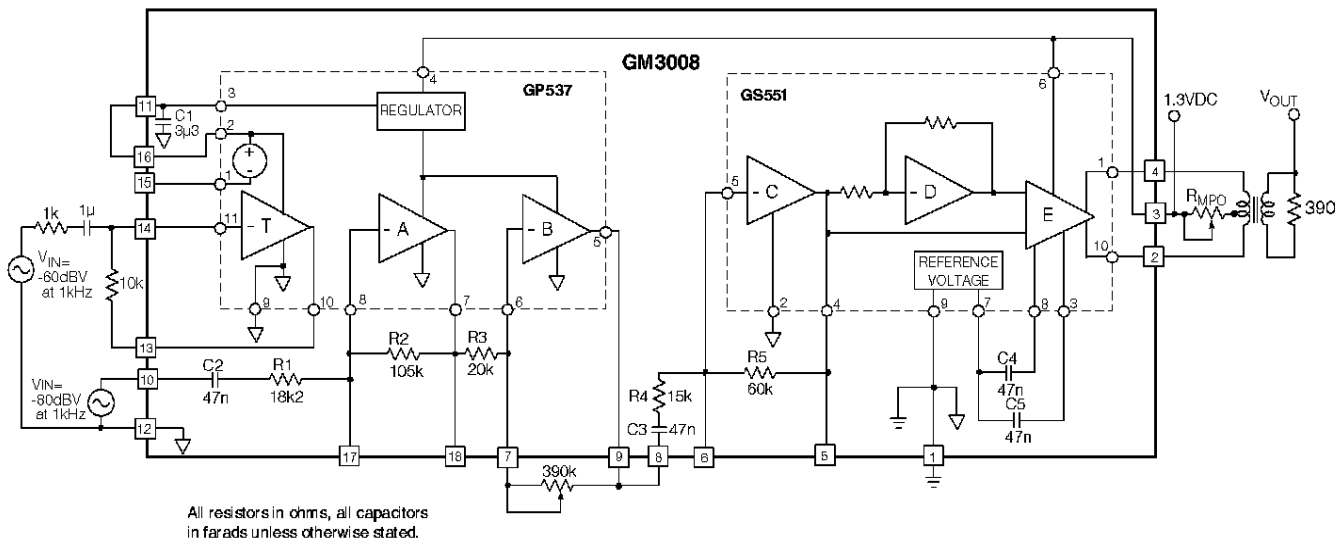

Fig. 4 Characterization Circuit (used to generate Typical Curves)

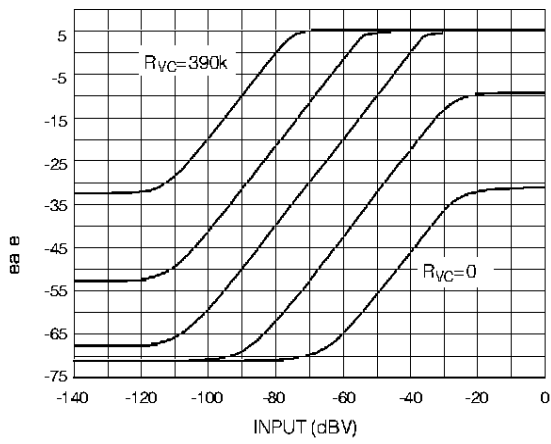

Fig. 5 Input vs Output as R_{VC} is Varied (Blocks A to E)

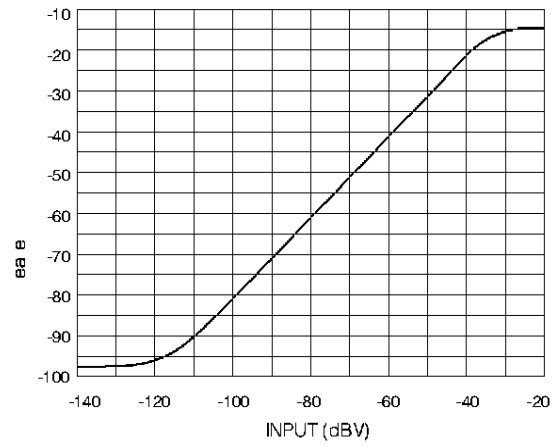

Fig. 6 Input vs Output (Telecoil)

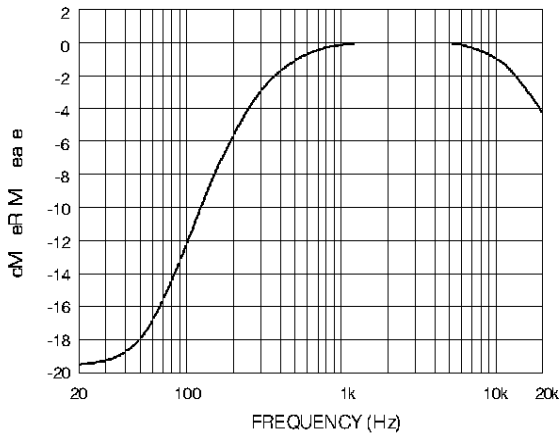

Fig. 7 Frequency Response (Blocks A to E)

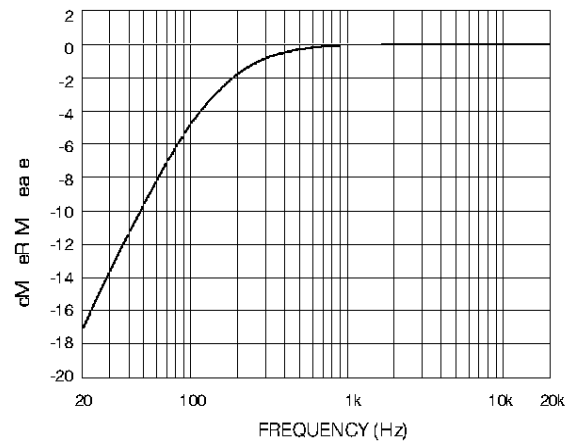

Fig. 8 Frequency Response (Telecoil)

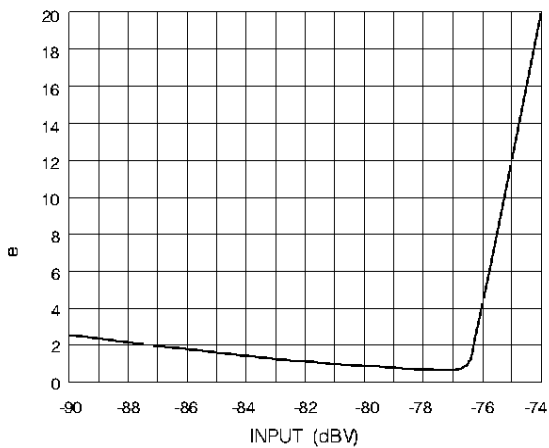

Fig. 9 THD vs Input (Blocks A to E)

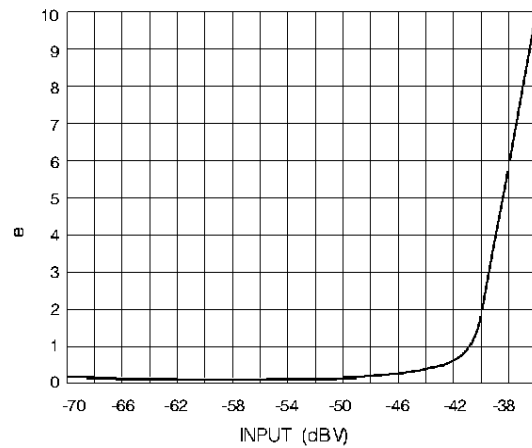

Fig.10 THD vs Input (Telecoil)

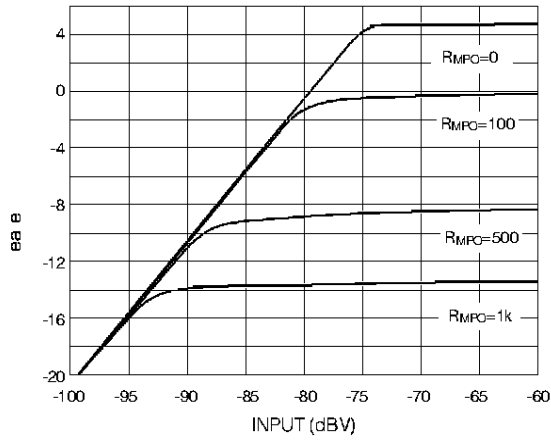

Fig. 11 Maximum Power Output vs R_{MPO}

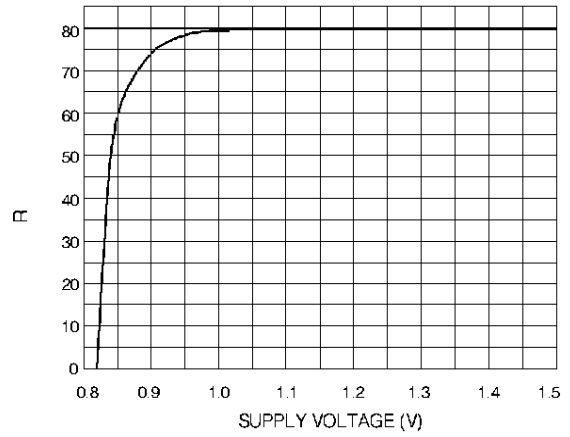

Fig. 12 Gain vs Supply Voltage

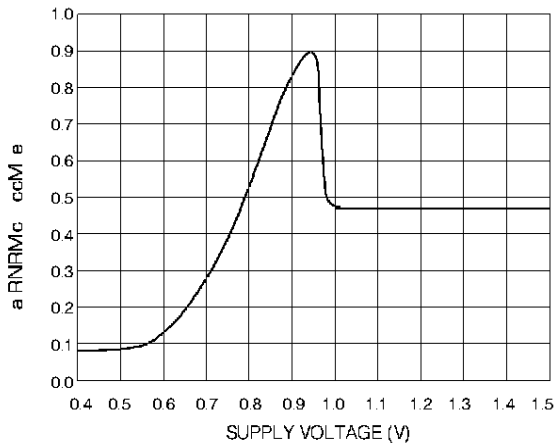

Fig. 13 Amplifier Current vs Supply Voltage

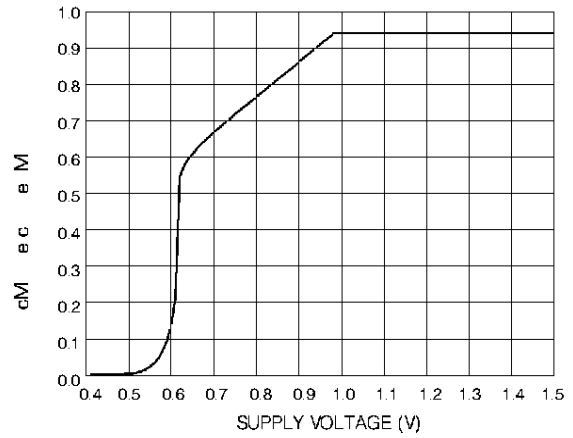

Fig. 14 Regulator Voltage vs Supply Voltage

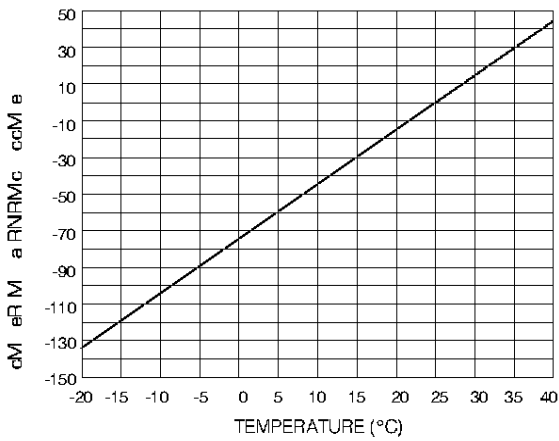

Fig. 15 Amplifier Current vs Temperature

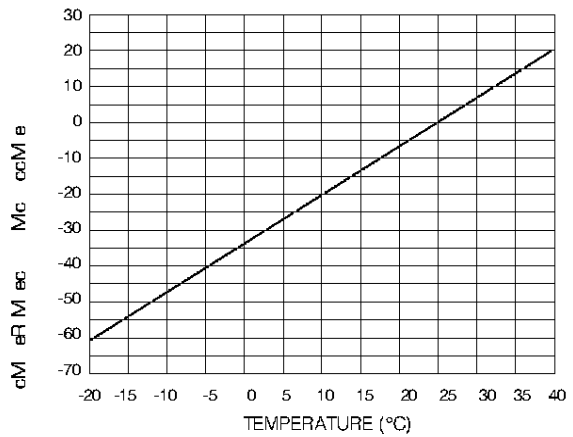
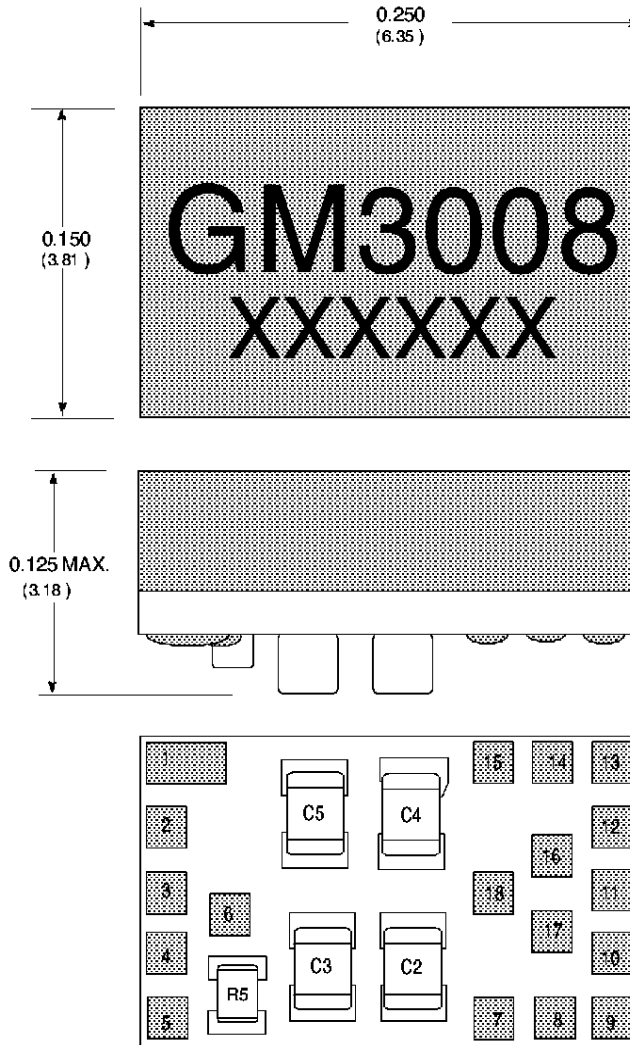

Fig. 16 Transducer Current vs Temperature



Dimensions are in inches.
 Dimensions shown in parenthesis are in millimetres, converted from inches and include minor round off errors.
 1.0000 inches = 25.40 mm.
 Dimension ± 0.005 (± 0.13) unless otherwise stated.
 Pad numbers for illustration only.
 Smallest pad 0.020 x 0.020 (pads 2 - 18).
 Largest pad 0.046 x 0.020 (pad 1).
 XXXXXX - work order number.
 This hybrid is designed for point to point manual soldering.

Fig. 17 Hybrid Layout and Dimensions

CAUTION
 CLASS 1 ESD SENSITIVITY

DOCUMENT IDENTIFICATION: DATA SHEET
 The product is in production. Gennum reserves the right to make changes at any time to improve reliability, function or design, in order to provide the best product possible.

REVISION NOTES:
 Updated to Data sheet