

Transmission Laser Modules

Key Features

InGaAsP monolithically integrated DFB laser and modulator in-house chip

Low drive voltage ($\leq 2V_{pp}$)

Very low dispersion penalty up to 90 km for 10.7Gbit/s operation (up to 1600ps/nm)

Based on XMD MSA package product platform (size & pin-out)

Leads for electrical connections

High output power [0;+4] dBm configuration

Wavelength selection according to ITU-T G.692

RoHS Compliant

Applications

Metro and Regional Metro SONET /SDH and D-WDM line card size and cost optimization

STM-64 (Long-Haul) and OC-192 (Long-Reach) SFF 300-pin MSA Transponder

10GbE 300-pin Transponder

Replacement of GPO-butterfly EML module

For more Info

Please contact us at:

North America: 514.748.4848
888.922.1044

Europe & Asia: +33 (0) 1 69 80 58 33
or via e-mail at sales@3spgroup.com

1925 LMM

10 Gb/s Electro-Absorptive Integrated Laser Modulator Optical Sub-Assembly 1600 ps/nm WDM and TDM – Pigtail

This 1925 LMM contains a 3SPGroup DFB laser with monolithically integrated electro-absorption modulator.

The modulation voltage is applied to the modulator section while the DFB laser operates CW. Without the complexity of LiNbO₃ external modulators, the 1925 LMM is dedicated to STM64 / OC-192 bit rate with reduced size and cost. This device allows 10 Gbit/s data transmission with an extinction ratio higher than 10dB and less than 2V modulation voltage.

The 1925 LMM is optimized for up to 10.7Gbit/s TDM and WDM transmission systems supporting dispersion up to 1600 ps/nm.

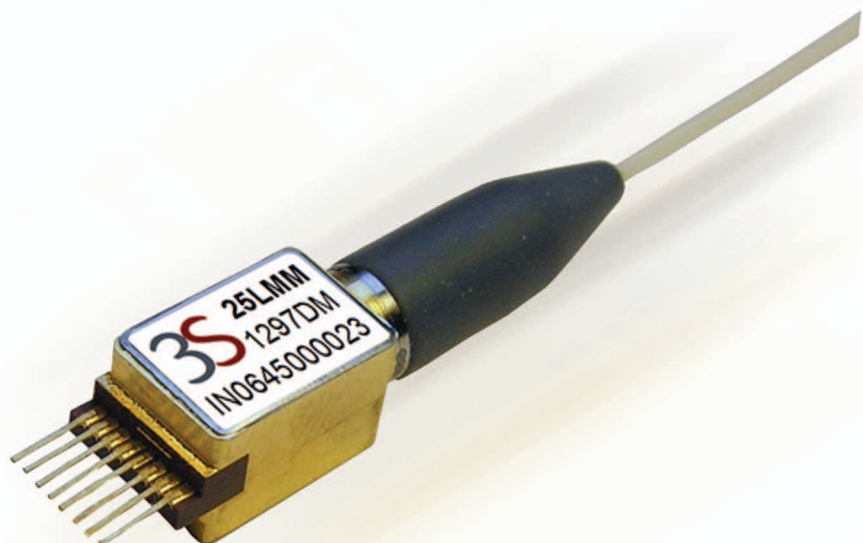

1925 LMM

**10 Gb/s Electro-Absorptive
Integrated Laser Modulator
Optical Sub-Assembly
1600 ps/nm WDM and TDM –
Pigtail**



OPTICAL CHARACTERISTICS

Parameters	Symb	Test conditions	Min	Max	Units
Operating case temperature	T _c		0	+70	°C
Laser Threshold current	I _{th}	V _{BM} =0V	5	35	mA
Laser operating current	I _{op}	V _{BM} =0V (BOL)	60	100	mA
Laser chip temperature range for tunability	T _{wave}	3CN01298##, 3CN01295##, 3CN01296##, 3CN01297##	20	35	°C
Modulator bias voltage	V _{BM}		-2	0	V
Modulator drive voltage	V _{pp}	Note 1		2	V _{pp}
Average optical output power	P _{AVG}	3CN01295##, 3CN01296##, 3CN01297 T _{wave} ; I _{op} ; DER, λ _c , notes 1, 2 3CN01299AB T _{chip} =25°C; I _{op} ; DER, λ _c , notes 1 & 2	-2	+2	dBm
Center wavelength range	λ _c	WDM (ITU grid)	1529.55	1569.55	nm
		TDM	1530	1570	
Dynamic Extinction Ratio	DER	I _{op} , Note 1, 2	10		dB
Dispersion Penalty	ΔS	DER, Note 1, 2		2	dB
Side Mode Suppression Ratio	SMSR	Note 1	35		dB
Monitor Diode Current	I _m	I _{op} , V=-5V	20	1500	μA
Dark Current	I _d	V=-5V		0.1	μA
TEC current	I _{tec}	V _{BM} = -2V @ 1600 ps/nm ΔT = 50°C, 1.2*I _{op}		1.3	A
TEC voltage	V _{tec}	V _{BM} = -1V, ΔT = 50°C, 1.2*I _{op}		2.5	V
Thermistor Resistance	R _{TH}	T _s =25°C	9.5	10.5	KΩ
Thermistor β Coefficient	β	T _s =25°C	3800	4000	K

Note 1 : BER= 10-10, 10.7Gb/s, modulation, 231-1 PRBS, NRZ line code

Note 2 : 1600 ps/nm minimum dispersion assuming fibre with an average dispersion of 17ps/nm/km @ 1550nm

Absolute Maximum Ratings

Exposure to absolute maximum rating conditions for extended periods may affect device reliability.

Parameters	Min	Max	Unit
Storage case temperature	-40	+85	°C
Laser Forward Current		150	mA
Laser Reverse Voltage		2	V
Laser Reverse Current		10	μA
Modulator Forward Voltage		1	V
Modulator Forward Current		100	mA
Modulator Reverse Voltage		5	V
Modulator Reverse Current		10	μA
Photodiode Forward Current		1	mA
Photodiode Reverse Voltage		20	V
TEC Voltage		2.6	V
TEC Current		1.4	A
Lead Soldering Temperature (at 260°C)		10	s

1925 LMM

**10 Gb/s Electro-Absorptive
Integrated Laser Modulator
Optical Sub-Assembly
1600 ps/nm WDM and TDM –
Pigtail**

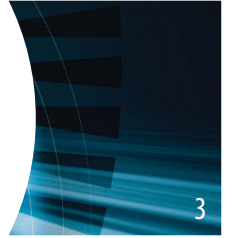
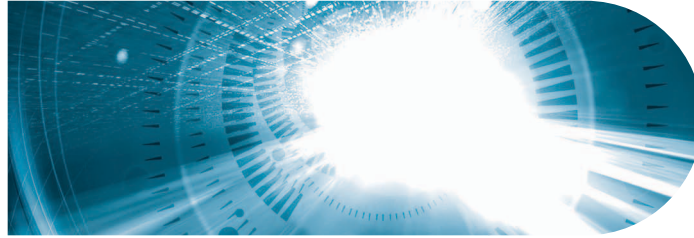

Mechanical Details

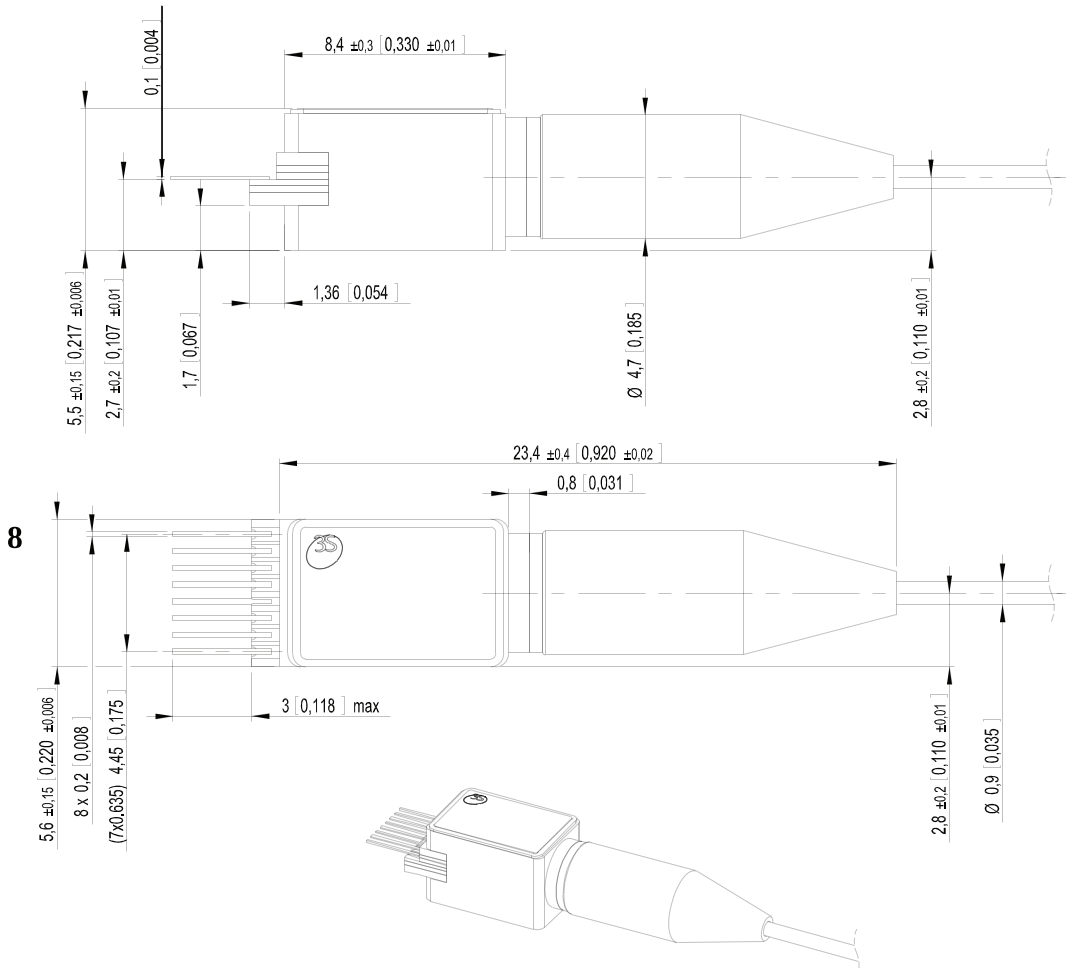

Dimensions are in mm
Fiber length 1600 ± 100 mm
(including optical connector)

Pin Out

N°	Description
1	TE Cooler Cathode
2	TE Cooler Anode
3	Floating signal ground
4	Modulator Anode (bias-)
5	Floating signal ground
6	PD Anode (bias -)
7	LD Anode (bias -)
8	Thermistor

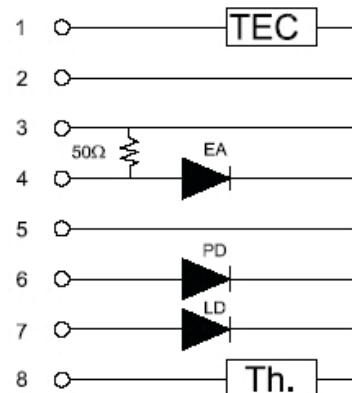

1925 LMM

**10 Gb/s Electro-Absorptive
Integrated Laser Modulator
Optical Sub-Assembly
1600 ps/nm WDM and TDM –
Pigtail**



4

Shipment **packing**

Each device is individually packed in an anti-static container and in such a manner as to prevent damage in transit.

The packing shall include the following information:

3S Photonics logo
Product family name : 1925 LMM
Product code : 3CN number (see Ordering information section)
Serial number
Hazard warning label (ESD)
Laser Safety Class Label

Laser Safety **Information**

Take appropriate precautions to prevent undue exposure to naked eye.

This product is classified Class 1M Laser Product according to IEC-60825-1: edition2.

All versions are Class IIIB laser products per 21 CFR 1040-10 Laser. Safety requirements under accession number 0120546-00.



Deliverable **data**

The following data shall be supplied with each device for WDM and Single Channel applications :

L(I) / V(I) / Im(I) curves
Values for Vmod, Von (On-state voltage [0 data]), Vbias (bias voltage), DER, SO (received optical power without fiber), DS and Pave for If
DER and dispersion penalty (DS)

For Single Channel applications :

Plot of SER vs Vmod over the range 0 V to -3 V @ If= 80 mA and Tc= Tsubmount= 25 °C

For WDM applications :

Plot of SER vs Vmod over the range 0 V to -3 V @ If, Twave and Tc= 25 °C

Handling

This product is sensitive to electrostatic discharge and should not be handled except at a static free workstation.

Take precautions to prevent ESD; use wrist straps, grounded work surfaces and recognized anti-static techniques when handling the product.

Handle the laser module by its package only, never hold it by its pigtail.

Care should be taken to avoid supply transient and over voltage. Over voltage above the maximum specified in absolute maximum rating section may cause permanent damage to the device.

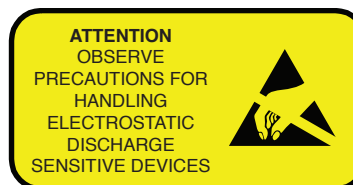

1925 LMM

**10 Gb/s Electro-Absorptive
Integrated Laser Modulator
Optical Sub-Assembly
1600 ps/nm WDM and TDM –
Pigtail**



5

ORDERING INFORMATION

Application	Part number	Output Power	Optical Connector
1600 ps/nm - WDM	3CN01295##	[-2, +2 dBm]	FC/PC
1600 ps/nm - WDM	3CN01296##	[-2, +2 dBm]	LC/PC
1600 ps/nm - WDM	3CN01297##	[-2, +2 dBm]	SC/PC
1600 ps/nm - TDM	3CN01299AB	[0, +4 dBm]	FC/PC

defines the wavelength according to the Table 3.

Table 3

λ (nm)	THz	Code ##	λ (nm)	THz	Code ##
1529,55	196,00	BP	1545,32	194,00	DF
1530,33	195,90	BR	1546,12	193,90	DH
1531,12	195,80	BT	1546,92	193,80	DK
1531,90	195,70	BV	1547,72	193,70	DM
1532,68	195,60	BX	1548,5	193,60	DP
1533,47	195,50	BZ	1549,32	193,50	DR
1534,25	195,40	CB	1550,12	193,40	DT
1535,04	195,30	CD	1550,92	193,30	DV
1535,82	195,20	CF	1551,72	193,20	DX
1536,61	195,10	CH	1552,52	193,10	DZ
1537,40	195,00	CK	1553,33	193,00	EB
1538,19	194,90	CM	1554,12	192,90	ED
1538,98	194,80	CP	1554,94	192,80	EF
1539,77	194,70	CR	1555,75	192,70	EH
1540,56	194,60	CT	1556,55	192,60	EK
1541,35	194,50	CV	1557,36	192,50	EM
1542,14	194,40	CX	1558,17	192,40	EP
1542,94	194,30	CZ	1558,98	192,30	ER
1543,73	194,20	DB	1559,79	192,20	ET
1544,53	194,10	DD	1560,61	192,10	EV

All wavelengths referenced to vacuum, Twave for WDM applications.

Revised March 2012

Please note: information in this document is typical and must be specifically confirmed in writing by your supplier before it becomes applicable to any order or contract.

Information is subject to change without notice.

©2011 3S PHOTONICS S.A.S.

ORDERING INFO

Please contact your Sales Manager. 3SPGroup can also develop custom products to meet a wide range of technical requirements.

3SPGroup

North America: 514.748.4848

888.922.1044

Europe and Asia: +33 (0)1 69 80 58 33

www.3spgroup.com • sales@3spgroup.com

