

54AC/74AC32 • 74ACT32 Quad 2-Input OR Gate

General Description

The 'AC/'ACT32 contains four, 2-input OR gates.

Features

- I_{CC} reduced by 50% on 54AC/74AC only
- Outputs source/sink 24 mA
- 'ACT32 has TTL-compatible inputs
- Standard Military Drawing (SMD)
 - 'AC32: 5962-87614
- For Military 54ACT32, see the 54ACTQ32

| Commercial | Military | Package Number | Package Description |
|---------------------|--------------------|----------------|---------------------------------------------------------|
| 74ACT32PC | | N14A | 14-Lead Molded Dual-In-Line (0.300" Wide) |
| 74ACT32SC (Note 1) | | M14A | 14-Lead Molded Small Outline (0.150" Wide), JEDEC |
| 74ACT32MTC (Note 1) | | MTC14 | 14-Lead Molded Thin Shrink Small Outline Package, JEDEC |
| | 54ACT32DM (Note 2) | J14A | 14-Lead Ceramic Dual-In-Line |
| | 54ACT32FM (Note 2) | W14B | 14-Lead Cerpak |
| | 54ACT32LM (Note 2) | E20A | 20-Lead Ceramic Leadless Chip Carrier, Type C |

Note 1: Devices also available in 13" Tape and Reel. Use suffix SCX, SJX, and MTCX.

Note 2: Military grade device with environmental and burn-in processing, use suffix DMOB, FMOB and LMOB.

Logic Symbol

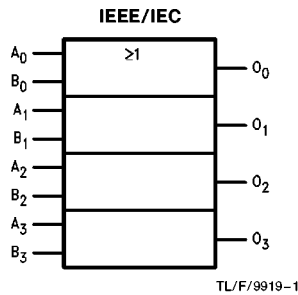

Connection Diagrams

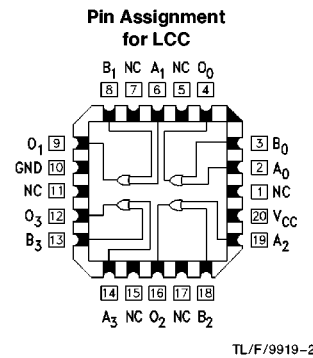
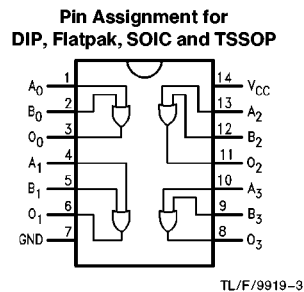

| Pin Names | Description |
|---------------------------------|-------------|
| A _n , B _n | Inputs |
| O _n | Outputs |

FACT™ is a trademark of National Semiconductor Corporation.

Absolute Maximum Rating (Note 1)

If Military/Aerospace specified devices are required, please contact the National Semiconductor Sales Office/Distributors for availability and specifications.

| | |
|------------------------------------------------------------------------|--------------------------|
| Supply Voltage (V_{CC}) | -0.5V to +7.0V |
| DC Input Diode Current (I_{IK}) | |
| $V_I = -0.5V$ | -20 mA |
| $V_I = V_{CC} + 0.5V$ | +20 mA |
| DC Input Voltage (V_I) | -0.5V to $V_{CC} + 0.5V$ |
| DC Output Diode Current (I_{OK}) | |
| $V_O = -0.5V$ | -20 mA |
| $V_O = V_{CC} + 0.5V$ | +20 mA |
| DC Output Voltage (V_O) | -0.5V to $V_{CC} + 0.5V$ |
| DC Output Source or Sink Current (I_O) | ±50 mA |
| DC V_{CC} or Ground Current per Output Pin (I_{CC} or I_{GND}) | ±50 mA |
| Storage Temperature (T_{STG}) | -65°C to +150°C |
| Junction Temperature (T_J) | |
| CDIP | 175°C |
| PDIP | 140°C |

Note 1: Absolute maximum ratings are those values beyond which damage to the device may occur. The databook specifications should be met, without exception, to ensure that the system design is reliable over its power supply, temperature, and output/input loading variables. National does not recommend operation of FACT™ circuits outside databook specifications.

Recommended Operating Conditions

| | | |
|-------------------------------------------------|-----------------|--|
| Supply Voltage (V_{CC}) | | |
| 'AC | 2.0V to 6.0V | |
| 'ACT | 4.5V to 5.5V | |
| Input Voltage (V_I) | 0V to V_{CC} | |
| Output Voltage (V_O) | 0V to V_{CC} | |
| Operating Temperature (T_A) | | |
| 74AC/ACT | -40°C to +85°C | |
| 54AC | -55°C to +125°C | |
| Minimum Input Edge Rate ($\Delta V/\Delta t$) | | |
| 'AC Devices | | |
| V_{IN} from 30% to 70% of V_{CC} | | |
| V_{CC} @ 3.3V, 4.5V, 5.5V | 125 mV/ns | |
| Minimum Input Edge Rate ($\Delta V/\Delta t$) | | |
| 'ACT Devices | | |
| V_{IN} from 0.8V to 2.0V | | |
| V_{CC} @ 4.5V, 5.5V | 125 mV/ns | |

DC Characteristics for 'AC Family Devices

| Symbol | Parameter | V_{CC} (V) | 74AC | | 54AC | 74AC | Units | Conditions | |
|----------|-----------------------------------|-----------------|---------------------------|-------------------|----------------------------|---------------------------|-------|----------------------------------------|------------------------------------------------------------------------|
| | | | $T_A = +25^\circ\text{C}$ | | $T_A =$ -55°C to +125°C | $T_A =$ -40°C to +85°C | | | |
| | | | Typ | Guaranteed Limits | | | | | |
| V_{IH} | Minimum High Level Input Voltage | 3.0 | 1.5 | 2.1 | 2.1 | 2.1 | V | $V_{OUT} = 0.1V$ or $V_{CC} - 0.1V$ | |
| | | 4.5 | 2.25 | 3.15 | 3.15 | 3.15 | | | |
| | | 5.5 | 2.75 | 3.85 | 3.85 | 3.85 | | | |
| V_{IL} | Maximum Low Level Input Voltage | 3.0 | 1.5 | 0.9 | 0.9 | 0.9 | V | $V_{OUT} = 0.1V$ or $V_{CC} - 0.1V$ | |
| | | 4.5 | 2.25 | 1.35 | 1.35 | 1.35 | | | |
| | | 5.5 | 2.75 | 1.65 | 1.65 | 1.65 | | | |
| V_{OH} | Minimum High Level Output Voltage | 3.0 | 2.99 | 2.9 | 2.9 | 2.9 | V | $I_{OUT} = -50 \mu\text{A}$ | |
| | | 4.5 | 4.49 | 4.4 | 4.4 | 4.4 | | | |
| | | 5.5 | 5.49 | 5.4 | 5.4 | 5.4 | | | |
| | | | 3.0 | | 2.56 | 2.4 | 2.46 | V | * $V_{IN} = V_{IL}$ or V_{IH} -12 mA I_{OH} -24 mA -24 mA |
| | | | 4.5 | | 3.86 | 3.7 | 3.76 | | |
| | | | 5.5 | | 4.86 | 4.7 | 4.76 | | |
| V_{OL} | Maximum Low Level Output Voltage | 3.0 | 0.002 | 0.1 | 0.1 | 0.1 | V | $I_{OUT} = 50 \mu\text{A}$ | |
| | | 4.5 | 0.001 | 0.1 | 0.1 | 0.1 | | | |
| | | 5.5 | 0.001 | 0.1 | 0.1 | 0.1 | | | |
| | | | 3.0 | | 0.36 | 0.5 | 0.44 | V | * $V_{IN} = V_{IL}$ or V_{IH} 12 mA I_{OL} 24 mA 24 mA |
| | | | 4.5 | | 0.36 | 0.5 | 0.44 | | |
| | | | 5.5 | | 0.36 | 0.5 | 0.44 | | |
| I_{IN} | Maximum Input Leakage Current | 5.5 | | ±0.1 | ±1.0 | ±1.0 | μA | $V_I = V_{CC}, \text{GND}$ | |

*All outputs loaded; thresholds on input associated with output under test.

DC Characteristics for 'AC Family Devices (Continued)

| Symbol | Parameter | V _{CC} (V) | 74AC | 54AC | 74AC | Units | Conditions | |
|------------------|----------------------------------|------------------------|------------------------|-------------------|-------------------------------------|-------|---------------------------------------------|------------------------------------|
| | | | T _A = +25°C | | T _A = -55°C to +125°C | | | T _A = -40°C to +85°C |
| | | | Typ | Guaranteed Limits | | | | |
| I _{OLD} | †Minimum Dynamic Output Current | 5.5 | | 50 | 75 | mA | V _{OLD} = 1.65V Max | |
| I _{OHD} | | 5.5 | | -50 | -75 | mA | V _{OHD} = 3.85V Min | |
| I _{CC} | Maximum Quiescent Supply Current | 5.5 | 2.0 | 40.0 | 20.0 | μA | V _{IN} = V _{CC} or GND | |

†Maximum test duration 2.0 ms, one output loaded at a time.

Note: I_{IN} and I_{CC} @ 3.0V are guaranteed to be less than or equal to the respective limit @ 5.5V V_{CC}.

I_{CC} for 54AC @ 25°C is identical to 74AC @ 25°C.

DC Characteristics for 'ACT Family Devices

| Symbol | Parameter | V _{CC} (V) | 74ACT | | 74ACT | Units | Conditions |
|-------------------|-----------------------------------|------------------------|------------------------|-------------------|------------------------------------|-------|---------------------------------------------------------------------------------------------|
| | | | T _A = +25°C | | T _A = -40°C to +85°C | | |
| | | | Typ | Guaranteed Limits | | | |
| V _{IH} | Minimum High Level Input Voltage | 4.5 | 1.5 | 2.0 | 2.0 | V | V _{OUT} = 0.1V or V _{CC} - 0.1V |
| | | 5.5 | 1.5 | 2.0 | 2.0 | | |
| V _{IL} | Maximum Low Level Input Voltage | 4.5 | 1.5 | 0.8 | 0.8 | V | V _{OUT} = 0.1V or V _{CC} - 0.1V |
| | | 5.5 | 1.5 | 0.8 | 0.8 | | |
| V _{OH} | Minimum High Level Output Voltage | 4.5 | 4.49 | 4.4 | 4.4 | V | I _{OUT} = -50 μA |
| | | 5.5 | 5.49 | 5.4 | 5.4 | | |
| | | 4.5 | | 3.86 | 3.76 | V | *V _{IN} = V _{IL} or V _{IH} -24 mA I _{OH} = -24 mA |
| | | 5.5 | | 4.86 | 4.76 | | |
| V _{OL} | Maximum Low Level Output Voltage | 4.5 | 0.001 | 0.1 | 0.1 | V | I _{OUT} = 50 μA |
| | | 5.5 | 0.001 | 0.1 | 0.1 | | |
| | | 4.5 | | 0.36 | 0.44 | V | *V _{IN} = V _{IL} or V _{IH} 24 mA I _{OL} = 24 mA |
| | | 5.5 | | 0.36 | 0.44 | | |
| I _{IN} | Maximum Input Leakage Current | 5.5 | | ±0.1 | ±1.0 | μA | V _I = V _{CC} , GND |
| I _{CC} T | Maximum I _{CC} /Input | 5.5 | 0.6 | | 1.5 | mA | V _I = V _{CC} - 2.1V |
| I _{OLD} | †Minimum Dynamic Output Current | 5.5 | | | 75 | mA | V _{OLD} = 1.65V Max |
| I _{OHD} | | 5.5 | | | -75 | mA | V _{OHD} = 3.85V Min |
| I _{CC} | Maximum Quiescent Supply Current | 5.5 | | 4.0 | 40.0 | μA | V _{IN} = V _{CC} or GND |

*All outputs loaded; thresholds on input associated with output under test.

†Maximum test duration 2.0 ms, one output loaded at a time.

AC Electrical Characteristics

| Symbol | Parameter | V _{CC} * (V) | 74AC | | | 54AC | | 74AC | | Units |
|------------------|-------------------|--------------------------|--------------------------------------------------|------------|------------|---------------------------------------------------------------|-------------|--------------------------------------------------------------|-------------|-------|
| | | | T _A = +25°C C _L = 50 pF | | | T _A = -55°C to +125°C C _L = 50 pF | | T _A = -40°C to +85°C C _L = 50 pF | | |
| | | | Min | Typ | Max | Min | Max | Min | Max | |
| t _{PLH} | Propagation Delay | 3.3 5.0 | 1.5 1.5 | 7.0 5.5 | 9.0 7.5 | 1.0 1.5 | 12.0 9.0 | 1.5 1.0 | 10.0 8.5 | ns |
| t _{PHL} | Propagation Delay | 3.3 5.0 | 1.5 1.5 | 7.0 5.0 | 8.5 7.0 | 1.0 1.5 | 11.5 8.5 | 1.0 1.0 | 9.0 7.5 | ns |

*Voltage Range 3.3 is 3.3V ±0.3V
Voltage Range 5.0 is 5.0V ±0.5V

AC Electrical Characteristics

| Symbol | Parameter | V _{CC} * (V) | 74ACT | | | 74ACT | | Units |
|------------------|-------------------|--------------------------|--------------------------------------------------|-----|-----|--------------------------------------------------------------|------|-------|
| | | | T _A = +25°C C _L = 50 pF | | | T _A = -40°C to +85°C C _L = 50 pF | | |
| | | | Min | Typ | Max | Min | Max | |
| t _{PLH} | Propagation Delay | 5.0 | 1.0 | 6.5 | 9.0 | 1.0 | 10.0 | ns |
| t _{PHL} | Propagation Delay | 5.0 | 1.0 | 6.5 | 9.0 | 1.0 | 10.0 | ns |

*Voltage Range 5.0 is 5.0V ±0.3V

Capacitance

| Symbol | Parameter | Typ | Units | Conditions |
|-----------------|-------------------------------|------|-------|------------------------|
| C _{IN} | Input Capacitance | 4.5 | pF | V _{CC} = OPEN |
| C _{PD} | Power Dissipation Capacitance | 20.0 | pF | V _{CC} = 5.0V |

Ordering Information

The device number is used to form part of a simplified purchasing code where the package type and temperature range are defined as follows:

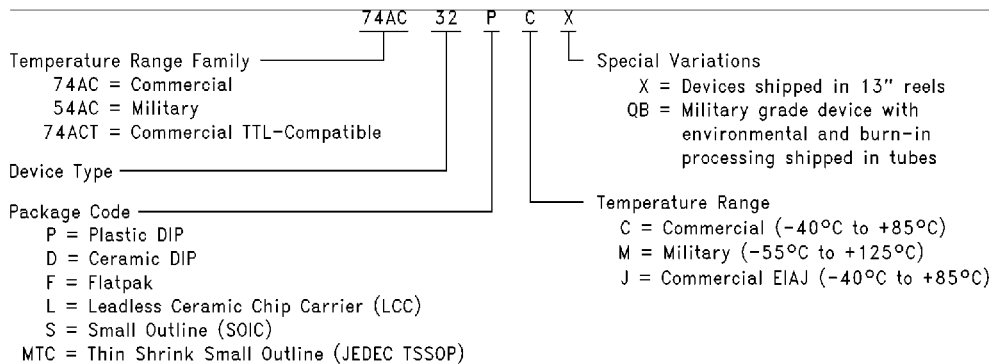

TL/F/9919-5

Physical Dimensions inches (millimeters) unless otherwise noted

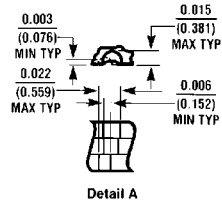
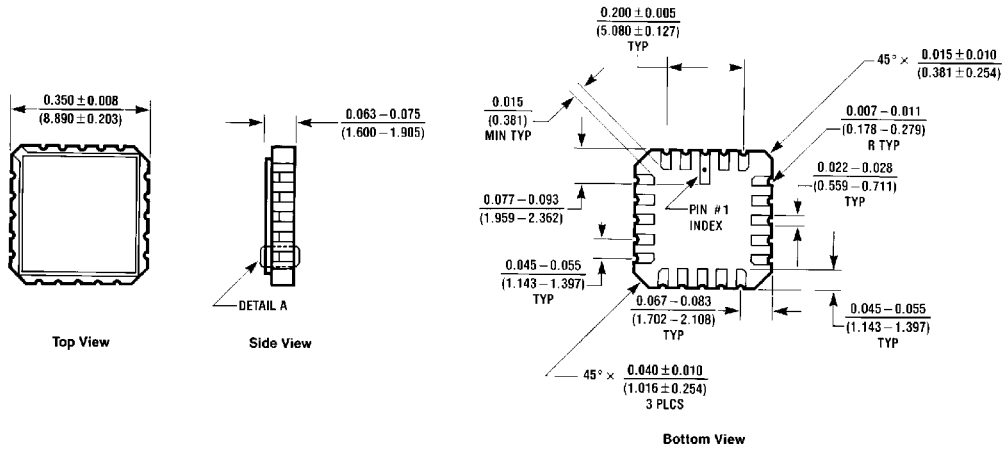

20 Terminal Ceramic Leadless Chip Carrier (L)
 NS Package Number E20A

E20A (REV D)

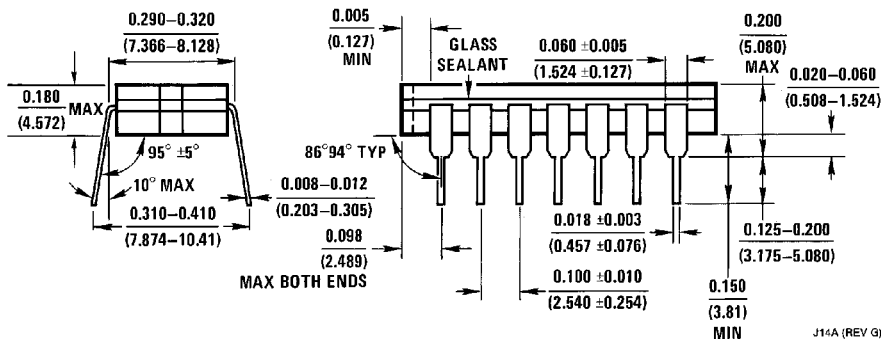
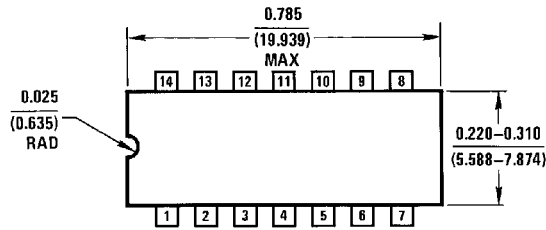

14-Lead Ceramic Dual-In-Line Package (D)
 NS Package Number J14A

J14A (REV G)

Physical Dimensions inches (millimeters) unless otherwise noted (Continued)

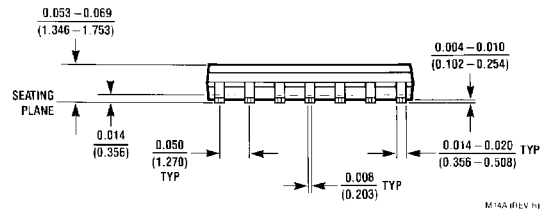
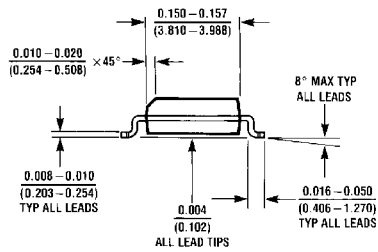
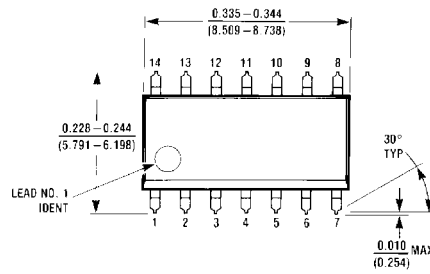

14-Lead Small Outline Integrated Circuit (S)
NS Package Number M14A

M14A dREV 14

Physical Dimensions inches (millimeters) unless otherwise noted (Continued)

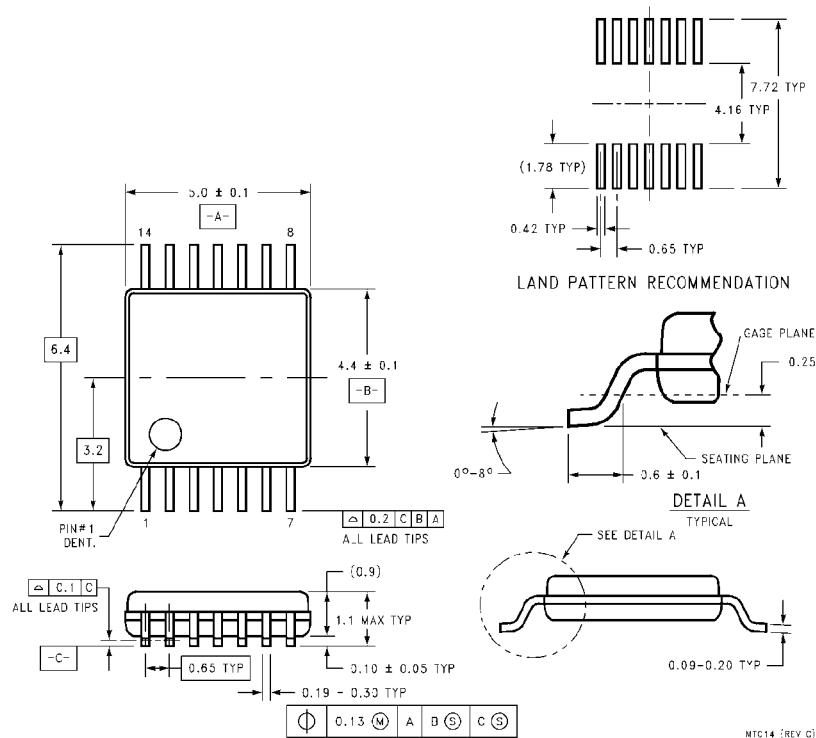

14-Lead Molded Thin Shrink Small Outline Package, JEDEC NS Package Number MTC14

MTC14 (REV C)

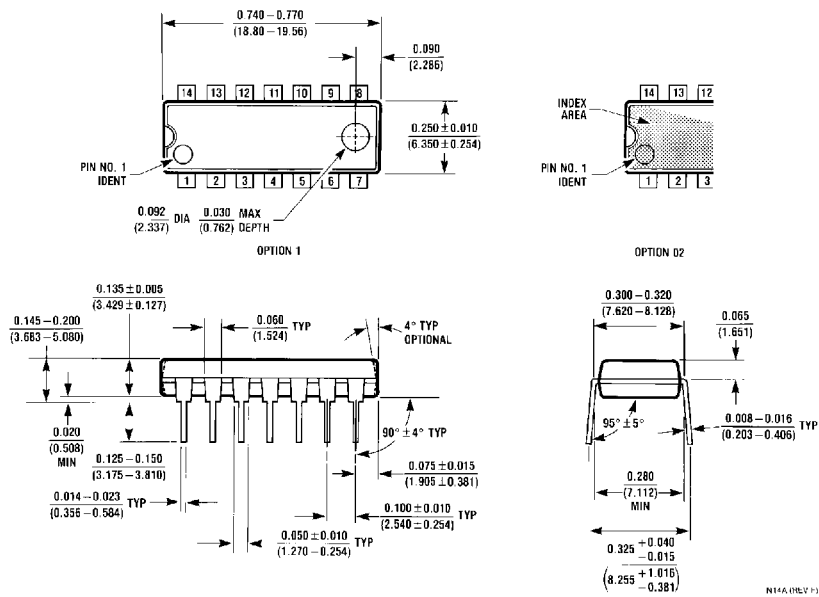

14-Lead Plastic Dual-In-Line Package (P) NS Package Number N14A

N14A (REV F)

Physical Dimensions inches (millimeters) unless otherwise noted (Continued)

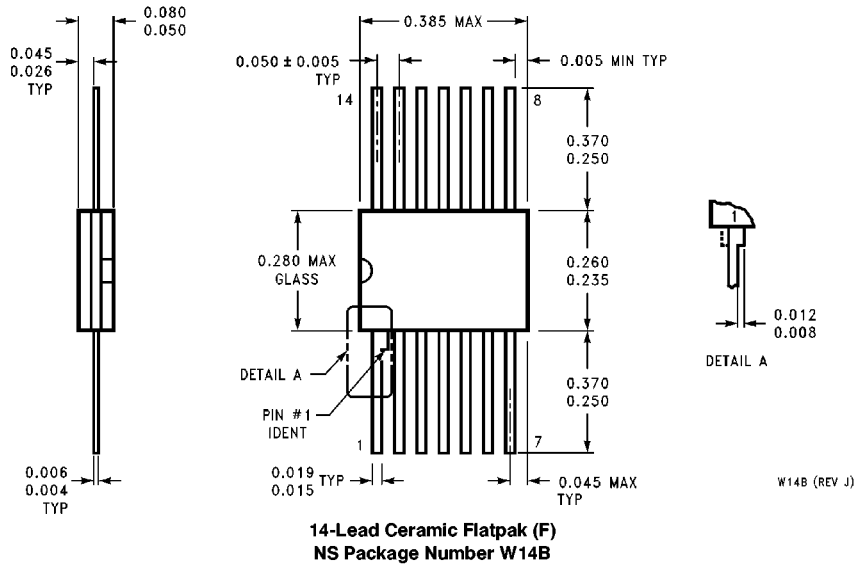

W14B (REV J)

LIFE SUPPORT POLICY

NATIONAL'S PRODUCTS ARE NOT AUTHORIZED FOR USE AS CRITICAL COMPONENTS IN LIFE SUPPORT DEVICES OR SYSTEMS WITHOUT THE EXPRESS WRITTEN APPROVAL OF THE PRESIDENT OF NATIONAL SEMICONDUCTOR CORPORATION. As used herein:

1. Life support devices or systems are devices or systems which, (a) are intended for surgical implant into the body, or (b) support or sustain life, and whose failure to perform, when properly used in accordance with instructions for use provided in the labeling, can be reasonably expected to result in a significant injury to the user.
2. A critical component is any component of a life support device or system whose failure to perform can be reasonably expected to cause the failure of the life support device or system, or to affect its safety or effectiveness.



National Semiconductor Corporation
1111 West Bardin Road
Arlington, TX 76017
Tel: 1(800) 272-9959
Fax: 1(800) 737-7018

<http://www.national.com>

National Semiconductor Europe
Fax: +49 (0) 180-530 85 86
Email: europe.support@nsc.com
Deutsch Tel: +49 (0) 180-530 85 85
English Tel: +49 (0) 180-532 78 32
Français Tel: +49 (0) 180-532 93 58
Italiano Tel: +49 (0) 180-534 16 80

National Semiconductor Hong Kong Ltd.
13th Floor, Straight Block,
Ocean Centre, 5 Canton Rd.
Tsimshatsui, Kowloon
Hong Kong
Tel: (852) 2737-1600
Fax: (852) 2736-9960

National Semiconductor Japan Ltd.
Tel: 81-043-299-2308
Fax: 81-043-299-2408

National does not assume any responsibility for use of any circuitry described, no circuit patent licenses are implied and National reserves the right at any time without notice to change said circuitry and specifications.